

## SB® 175 Connectors

Up to 280 Amps



Wires sizes from 10 to 1/0 AWG (5.3 to 50 mm<sup>2</sup>) fit in the second to largest connector in the SB® series. The 3 pole SB® 175 adds an additional position for power or grounding. All Multipole wire connector housings are genderless and mate to themselves minimizing inventory and assembly complexity.

- **Silver Plated Wire Contacts up to 1/0 (50 mm<sup>2</sup>)**

*Allows UL rated currents up to 280 amps*

- **Chemical Resistant Housing Option**

*Extends temperature range down to -40°C, while offering enhanced UV and chemical resistance*

- **UL Rated for Hot Plugging up to 100 Amps**

*Great for battery or other applications where the ability to interrupt circuits is required*

## SB® 175 ORDERING INFORMATION

### SB® 175 Standard Housings

The second to largest SB® housings work with wire contacts up to 1/0 AWG (50 mm<sup>2</sup>) as well as busbar contacts. Genderless design mates with itself. Mechanical keys are color-coded. *NOTE: SB® 175 black housing is keyless and can be mated with all other colors.*

Description	Part Numbers	
Minimum Quantity	200	50
Yellow	943-BK	943
Orange	942-BK	942
Red	949-BK	949
Gray	940-BK	940
Blue	941-BK	941
Black (Keyless)	2-7252G11	-

### SB® 175 Chemical Resistant Housings

Same features as the Standard SB® 175 but molded in a chemical resistant PBT/ PC blend. Suitable for use to -40°C.

Description	Part Numbers	
Minimum Quantity	200	50
Red	P949-BK	P949
Gray	P940-BK	P940

### SB® 175 2/0 Housing

Genderless design mates with itself. Can be cross mated with gray SB® 175 housing, but amperage capability is limited to the SB® 175 rating with the wire and contact used.

Description	Voltage	Part Number
Minimum Quantity		100
Gray	36V	115107G1

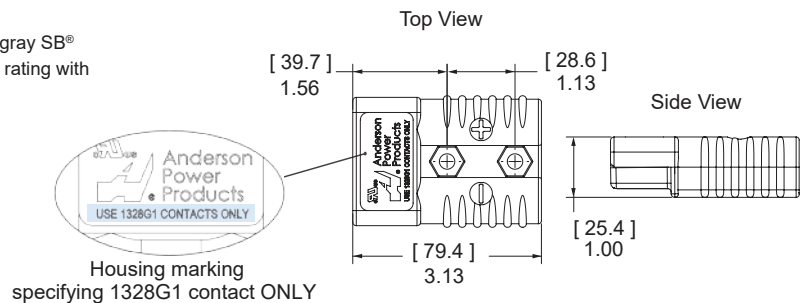
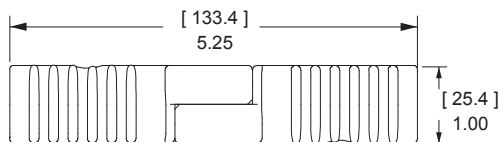
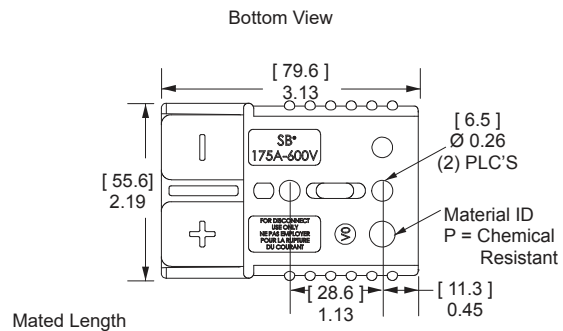

### SB® 175 3 Pole Housings & Hardware

A three pole version of the standard SB® 175 housing has a two piece housing with springs and hardware. Useful for DC 2 wire plus ground and AC single phase applications.

Description	Part Numbers	
Minimum Quantity	100	25
Gray Housing and Hardware Kit	-	902
Gray Housing Top Half	2-5048	-
Gray Housing Bottom Half	2-5049	-
Hardware Kit	-	110G34

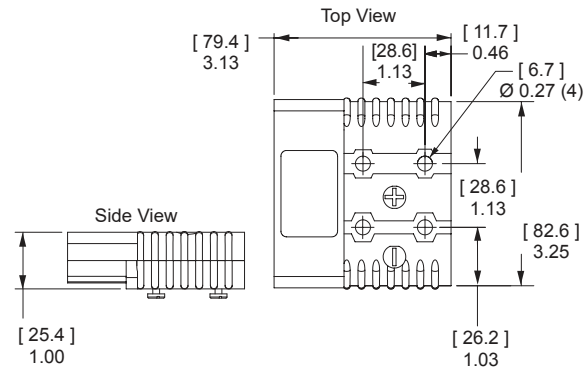

### SB® 175 Silver Plated Wire Contacts

Silver plated contacts offer superior electrical performance and durability up to 10,000 mating cycles. See reducing bushings in accessory section for smaller wires.

AWG	mm <sup>2</sup>	Mating Force	Loose Piece Part Numbers	Dimensions							
				- A -		- B -		- C -		- D -	
				inches	mm	inches	mm	inches	mm	inches	mm
Minimum Quantity			500 50								
1/0	53.5	High	1382-BK 1382	2.35	59.69	0.52	13.21	0.44	11.18	1.04	26.42
1	42.4	High	1347-BK 1347	2.35	59.69	0.52	13.21	0.39	9.91	1.04	26.42
2	33.6	High	1383-BK 1383	2.35	59.69	0.52	13.21	0.35	8.89	1.04	26.42
4	21.1	High	1384-BK 1384	2.35	59.69	0.52	13.21	0.30	7.62	1.04	26.42
6	13.3	High	1348-BK 1348	2.10	53.34	0.37	9.40	0.22	5.59	0.80	26.42
2/0 *	70	Low	1328G1-BK 1328G1	2.35	59.69	0.64	16.26	0.49	12.45	1.04	26.42

\* Use with 115107G1 only

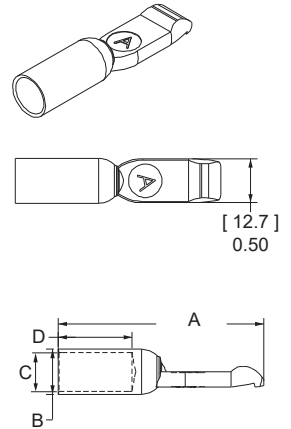

### SB® 175 Silver Plated Busbar Contacts

Provides a quick disconnect input or output busbar connection. Busbar contacts are for mating with wire contacts only. Part number 180BBS includes lock nuts. Locknuts must be ordered separately for 180BBS-BK.

Type	Thread	Mating Force	Loose Piece Part Numbers		
Minimum Quantity			1,000	120	10
Busbar	1/4-20	High	-	180BBS-BK	180BBS
Lock Nut	1/4-20	-	H1216P7	110G56	110G55

See Busbar contact drawing on website for further detail.

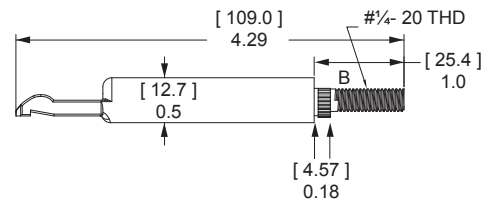

### Silver Plated Wire Contacts - use with 2/0 Housing ONLY

Silver plated contacts offer superior electrical performance and durability up to 5,000 mating cycles.

Type	AWG	mm <sup>2</sup>	Loose Piece Part Numbers	Dimensions							
				- A -		- B -		- C -		- D -	
				inches	mm	inches	mm	inches	mm	inches	mm
Minimum Quantity			300 50								
Individual	2/0	70	1328G1-BK 1328G1	2.35	59.69	0.64	16.26	0.49	12.45	1.04	26.42

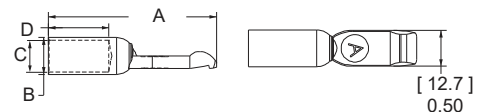

**SB® 175 CONNECTOR TEMPERATURE CHARTS** - Temperature rise charts are based on a 25°C ambient temperature.

Current - Temperature Derating per IEC 60512-5-2 Test 5B

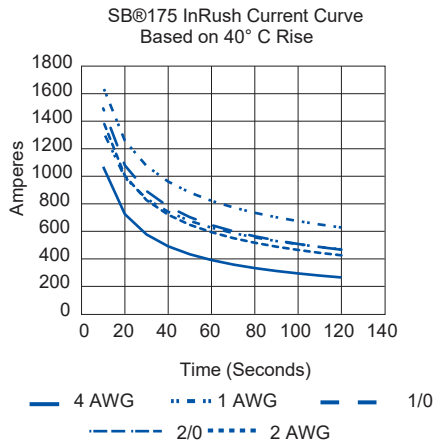
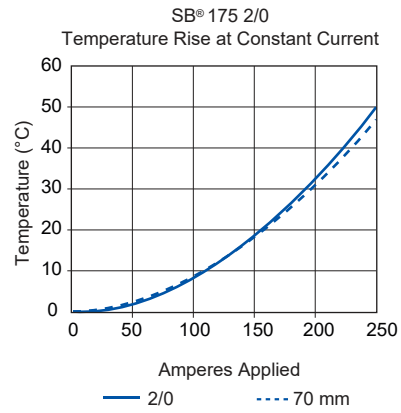
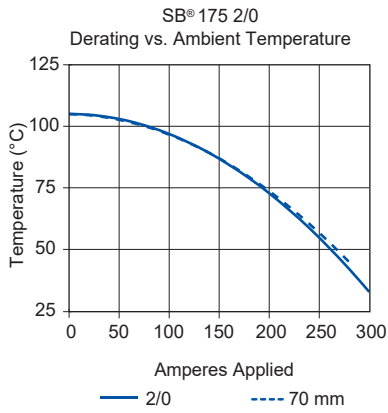
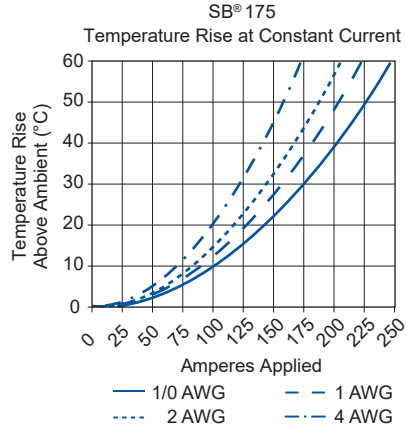
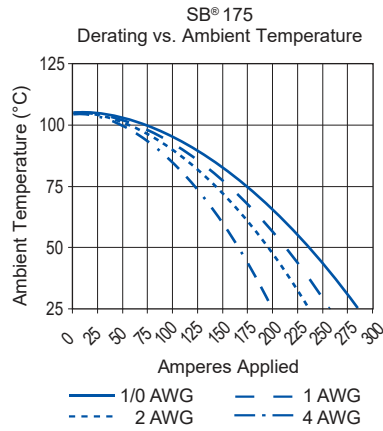

# SB® 175 CONNECTOR SPECIFICATIONS

ELECTRICAL		
<b>Current Rating Amperes <sup>1</sup></b>	<b>UL 1977</b>	<b>CSA</b>
Wire-to-Wire (1/0 AWG)	280	175
Wire-to-Busbar (1/0 AWG)	200	
3 Pole Wire-to-Wire (1/0 AWG)	175	
<b>Voltage Rating AC/DC</b>		
UL 1977	600	
<b>Dielectric Withstanding Voltage</b>		
Volts AC	2,200	
<b>Avg. Mated Contact Resistance Milliohms <sup>1</sup></b>		
6" of 1/0 AWG wire	0.100	
<b>Hot Plug Current Rating Amperes - Wire &amp; Busbar</b>		
250 cycles at 120V DC 1/0 Wires	100A	

MATERIALS	
<b>Housing</b>	
Standard Plastic Resin	Polycarbonate
Chemical Resistant Resin	Polycarbonate / PBT blend
Contact Retention Spring	Stainless Steel
<b>Housing Flammability Rating</b>	
UL94	V-0
Glow Wire	960°C (GWFI) / 850°C (GWIT)
<b>Wire &amp; Busbar Contacts</b>	
Base	Copper Alloy
Plating	Silver
<b>Contact Termination Methods</b>	
Crimp <sup>3</sup>	Wire Contacts
Hand Solder	Wire Contacts
Wrench / Socket	Busbar Contacts Only

MECHANICAL		
<b>Wire Size Range</b>	<b>AWG</b>	<b>mm<sup>2</sup></b>
Wire Contacts with Bushings	10 to 1/0	5.3 to 53.5
<b>Max. Wire Insulation Diameter</b>	<b>in.</b>	<b>mm</b>
	0.600	15.240
<b>Operating Temperature <sup>2</sup></b>	<b>°F</b>	<b>°C</b>
Standard	-4° to 221°	-20° to 105°
Chemical Resistant	-40 to 221°	-40° to 105°
<b>Mating Cycles No Load by Plating</b>	<b>Silver (Ag)</b>	
Wire and Busbar Contacts	10,000	
<b>Avg. Mating / Unmating Force</b>	<b>Lbf.</b>	<b>N</b>
2 Pole	25	111
3 Pole	35	156
<b>Min. Contact / Spring Retention Force</b>	<b>Lbf.</b>	<b>N</b>
	150	667
<b>Mechanical Shock <sup>4</sup></b>		
MIL-STD-202	213 Condition A	50g's
<b>Vibration High Frequency <sup>4</sup></b>		
MIL-STD-202	204 Condition A	10g's



NOTE 1: See IEC 60664-1 for working voltage.

NOTE 2: Amp ratings are stated per position and based on all positions being fully loaded.

1 - Based on: 105°C rated or better cable of the largest size. Properly calibrated Anderson Power™ recommended tooling, and a 25°C ambient temperature. UL rating not to exceed the maximum operating temperature. CSA rating below a 30°C temperature rise.

2 - Limited by the thermal properties of the connector plastic housing.

3 - Use Anderson Power™ recommended tooling only. Alternate tools may adversely affect the performance of our connectors along with UL and CSA recognition.

4 - Tested with contact part number 1382.

## SB® 175 CONNECTOR IEC INFORMATION

Connector Series	Configurations	Creepage / Clearance per IEC 60950-1	Material Group
SB® 175	Unmated	5.73 mm	IIIa
	Mated	5.73 mm	

### PROTECTION

#### Touch Safety with Wire Contacts

IEC 60529 IP10 unmated

#### Environmental Sealing with Boots

IEC 60529 IP64



ATTRIBUTES	SB® 175
AMP Rating AC/DC	175
Voltage Rating AC/DC (Steady State)	500 V AC/DC (Operational)
Breaking Capacity - AMP Rating / Cycles	175 Amp / 10 Cycles
Voltage Rating (Breaking Capacity)	220 VDC
Finger Safety - Mated Only	IEC 60529 - IP20
Wire Size Tested	50 mm <sup>2</sup>
Contact Series Tested	1382
Climatic Testing (Cold, Heat & MFG)	IEC 60512 Test-11j, 11i & 11g
Cycle Life	IEC 60512 Test 9a- 5000 Cycles
Mechanical Strength Impact	IEC 60512-5 @ 29.5 Inches-Dropped 8 Times
Temperature Range	-20 °C to 105 °C -4 °F to 221 °F

## SB® 175 2/0 CONNECTOR SPECIFICATIONS

### ELECTRICAL

Current Rating (Amperes) <sup>1</sup>	UL 1977	CSA
2/0 AWG	340	200
70 mm <sup>2</sup>	315	185
Voltage Rating (AC/DC)	600	
Dielectric Withstanding Voltage (AC)	2,200	
AVG Contact Resistance (milli-ohms) <sup>1</sup>	0.045	

### MATERIALS

Standard Housing	PC
Flammability Rating	UL94 V-0
Wire Power Contact	Copper Alloy, Silver Plate

#### Contact Termination Methods

Crimp <sup>3</sup>

Hand Solder

### MECHANICAL

Contact Wire Range (AWG)	2/0	
(mm <sup>2</sup> )	70	
MAX Wire Insulation Diameter (in)	0.67	
(mm)	17.04	
Operating Temperature <sup>2</sup>	°C	°F
PC Housing	-20° to 105°	-4° to 221°
AVG Contact Retention Force for Standard PC Housing	(lbf)	150 lbf
	(N)	667 n
Mating Cycles (no load)	5,000	
Connector AVG Connect / Disconnect	(lbf)	55
	(N)	245



<sup>1</sup> Based on: 105°C rated or better cable of the largest size. Properly calibrated Anderson recommended tooling, and a 25°C ambient temperature. UL rating not to exceed the maximum operating temperature. CSA rating below a 30°C temperature rise.

<sup>2</sup> Limited by the thermal properties of the connector plastic housing.

<sup>3</sup> Use Anderson recommended tooling only. Alternate tools may adversely affect the performance of our connectors along with UL and CSA recognition.

# SB® 175 ACCESSORIES

## Cable Clamps

Durable metal cable clamps securely hold cables to prevent accidental strain or pulls from dislodging wire or contacts from the housing. Only Bolt On type clamps can be used with the handles. Cable clamps are recommended for solder terminated wires. Not for use with 3 pole housing.

Description	Cable Size		Part Numbers	
	Max / Min In. Inches O.D.	Max / Min mm mm O.D.	100	50
Self Attaching for Discrete Conductor	0.55 to 0.24	14 to 6	945-BK	945
Bolt on for Discrete Conductor	0.66 to 0.24	16.7 to 6.2	945G3-BK	945G3
Bolt on for Bundled Conductor	0.75 to 0.29	18.3 to 7.3	946G1-BK	946G1

\* Torque value 30 (in - lbs) / 3.4 (Nm)

NOTE: For assembly of clamp to housing only

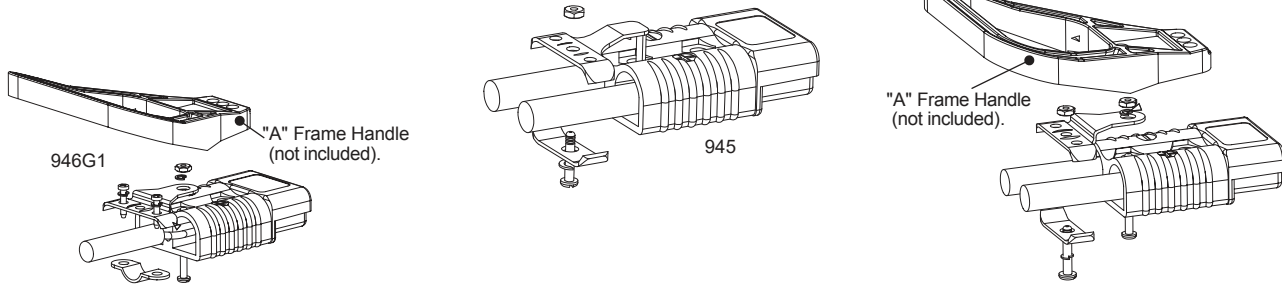

The given wire O.D. information is an estimate. Cable clamps should be evaluated for performance with the actual wire to be used.

## Handles

Handles are made out of durable PC plastic. Hardware to attach to connector body included in kits. Not for use with 3 pole housing.

Description	Part Numbers	
Minimum Quantity	100	25
Gray Handle Kit	-	995G1
Red Handle Kit	-	995G3
Handle Only, Gray	3-5074P1	-
Handle Only, Red	3-5074P3	-
Handle Only, Black	3-5074P5	-
Hardware Bag	-	105G8

\* Torque value 30 (in lbs) / 3.4 (Nm)

NOTE: For assembly of clamp to housing only

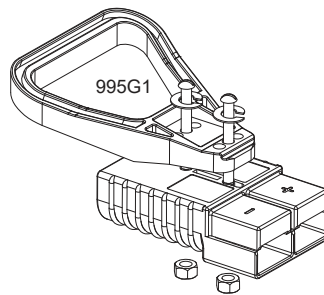

## Dust Cover

Prevents dust and dirt from entering the mating interface of the connector when unmated. NOTE: Not a Hermetic Seal. Not for use with 3 pole housing.

Description	Part Numbers	
Minimum Quantity	500	50
Dust Cover with Lanyard Strap, Red	113890P2	134G2

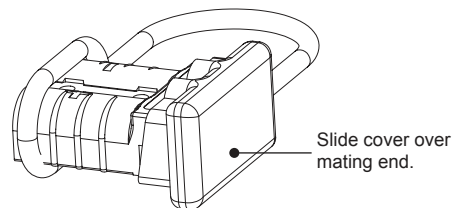

## SB® Environmental Boots

SB® Environmental Boots provide water, dirt, chemical and UV protection for SB® 175 connectors. The durable boots shield the connectors from water and dirt to IP64\* in both the mated and unmated condition.

Description	Part Numbers		Dimensions					
			- A -		- B -		- C -	
			in.	mm	in.	mm	in.	mm
Minimum Quantity	250	25						
SB® 175 Environmental Boot, Load	3-6037P1-BK	3-6037P1	9.5	241	3.2	80	9.3	236
SB® 175 Environmental Boot, Source	3-6036P1-BK	3-6036P1	9.5	241	3.2	80	9.3	236

\* IP64 test pending

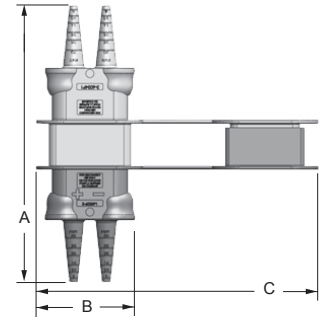

## SB® 175 Lockout

Works with standard lockout - tagout equipment to prevent access to the mating interface of the connector. Made from durable PC plastic. Can be used with 3 pole housing to lockout positive and negative positions only.

Description	Part Number
Minimum Quantity	25
Red Lockout - Tagout Kit	SB175-LOCKOUT

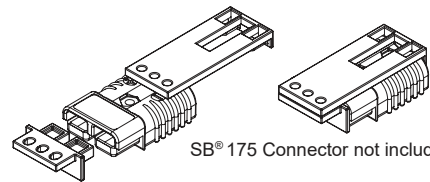

SB® 175 Connector not included.

## Silver Plated Reducing Bushings: for Use with Contact Part Number 1382

Use with contact part number 1382-BK to allow a smaller wire to be used with the connector. Electrical capability is derated with smaller wire.

Contact Barrel Size		Wire Size		Part Numbers				Dimensions - ID -	
AWG	mm <sup>2</sup>	AWG	mm <sup>2</sup>					inches	mm
Minimum Quantity									
1/0	53.5	1	42.4	1,500	1,000	500	100	0.39	9.91
1/0	53.5	2	33.6	5690-BK	-	-	5687	0.34	8.64
1/0	53.5	4	21.2	-	5693-BK	-	5693	0.27	6.86
1/0	53.5	6	13.3	-	5663-BK	-	5663	0.22	5.59
1/0	53.5	10 to 8	5.3 to 8.4	5648-BK	-	-	5648	0.19	4.83

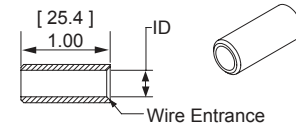

## SB® Tooling Information

Wire Size		Loose Piece Part Number	Loose Piece Contact Crimp Tools							
AWG	mm <sup>2</sup>	Silver Plating	Hand Tool	OR	Pneumatic Tool	+	Die	+	Locator	Number of Crimps
<b>SB® 175</b>										
1/0	53.5	1382	1368 Series	OR	1387G2	+	1303G13	+	1304G32	Double
1	42.4	1347								
2	33.6	1383								
4	21.1	1384			1387G1	+	1388G4	+	1389G3	Single
6	13.3	1348								
2/0	53.5	1328G1			1387G2	OR	1303G12	+	1304G32	+

NOTE: See website for the most current information.

## SB® 2/0 Tooling Information

Wire Size		Loose Piece Part Number	Loose Piece Contact Crimp Tools							
AWG	mm <sup>2</sup>	Silver Plating	Hand Tool	OR	Pneumatic Tool	+	Die	+	Locator	Number of Crimps
2/0	53.5	1328G1	1368	OR	1387G2	+	1303G12	+	1304G32	Double

NOTE: See website for the most current information.

All Data Subject to Change Without Notice 2023-0025 DS-SB175 REV 8 **Your Best Connection™**

Anderson™ will use reasonable efforts to include accurate and up-to-date content in the data sheet. All product information contained in the data sheet including ordering information, illustrations, specifications, and dimensions, are believed to be reliable as of the date of publishing, but is subject to change without notice. Anderson™ makes no warranty or representation as to its accuracy. Content in the data sheet may contain technical inaccuracies, typographical errors and may be changed or updated without notice. Anderson™ may also make improvements and/or changes to the products and/or to the programs described in the content at any time without notice. Current sales drawings and specifications are available upon request.

©2023 Anderson Power Products, Inc. All rights reserved. A®, Anderson Power Products®, SB®, are registered trademarks of Anderson Power Products, Inc. Anderson™, Anderson Power™, Anderson Power™ logo and Your Best Connection™ are trademarks of Anderson Power Products, Inc.



**HEADQUARTERS:** Anderson Power Products®, 13 Pratts Junction Road, Sterling, MA 01564-2305 USA T: +1 978-422-3800 F: +1 978-422-0128 • **EUROPE:** Anderson Power Products® Ltd., Unit 3, Europa Court, Europa Boulevard, Westbrook, Warrington, Cheshire, WA5 7TN United Kingdom T: +44 (0) 1925 428390 F: +44 (0) 1925 520203 • **GERMANY:** IDEAL® Industries Germany GmbH, Esslinger Strasse 7, D – 70771 Leinfelden-Echterdingen, T: +49 (0) 711 – 997606666 • **ASIA / PACIFIC:** IDEAL® Anderson Asia Pacific Ltd., Unit 922-928 Topsail Plaza, 11 On Sum Street, Shatin N.T., Hong Kong T: +(852) 2636 0836 F: +(852) 2635 9036 • **INDIA:** IDEAL® INDUSTRIES India Private Limited, 229-230, SPAZEDGE, Tower B, Sector 47, Sohna Road, Gurgaon – 122018, Haryana, India T: +(91) 956-0075905 T: +(91) 124-4495101 • **CHINA:** IDEAL® Anderson Technologies (Shenzhen) Ltd., Block A8 Tantou Western Industrial Park, Songgang Baoan District, Shenzhen, PR. China 518105 T: +(86) 755 2768 2118 F: +(86) 755 2768 2218 • [www.ideal-industries.in](http://www.ideal-industries.in) • [www.andersonpower.com](http://www.andersonpower.com)