



MICROCHIP

**MCP16301 High Voltage
Buck Converter
600 mA Demo Board
User's Guide**

Note the following details of the code protection feature on Microchip devices:

- Microchip products meet the specification contained in their particular Microchip Data Sheet.
- Microchip believes that its family of products is one of the most secure families of its kind on the market today, when used in the intended manner and under normal conditions.
- There are dishonest and possibly illegal methods used to breach the code protection feature. All of these methods, to our knowledge, require using the Microchip products in a manner outside the operating specifications contained in Microchip's Data Sheets. Most likely, the person doing so is engaged in theft of intellectual property.
- Microchip is willing to work with the customer who is concerned about the integrity of their code.
- Neither Microchip nor any other semiconductor manufacturer can guarantee the security of their code. Code protection does not mean that we are guaranteeing the product as "unbreakable."

Code protection is constantly evolving. We at Microchip are committed to continuously improving the code protection features of our products. Attempts to break Microchip's code protection feature may be a violation of the Digital Millennium Copyright Act. If such acts allow unauthorized access to your software or other copyrighted work, you may have a right to sue for relief under that Act.

Information contained in this publication regarding device applications and the like is provided only for your convenience and may be superseded by updates. It is your responsibility to ensure that your application meets with your specifications. MICROCHIP MAKES NO REPRESENTATIONS OR WARRANTIES OF ANY KIND WHETHER EXPRESS OR IMPLIED, WRITTEN OR ORAL, STATUTORY OR OTHERWISE, RELATED TO THE INFORMATION, INCLUDING BUT NOT LIMITED TO ITS CONDITION, QUALITY, PERFORMANCE, MERCHANTABILITY OR FITNESS FOR PURPOSE. Microchip disclaims all liability arising from this information and its use. Use of Microchip devices in life support and/or safety applications is entirely at the buyer's risk, and the buyer agrees to defend, indemnify and hold harmless Microchip from any and all damages, claims, suits, or expenses resulting from such use. No licenses are conveyed, implicitly or otherwise, under any Microchip intellectual property rights.

Trademarks

The Microchip name and logo, the Microchip logo, dsPIC, KEELOQ, KEELOQ logo, MPLAB, PIC, PICmicro, PICSTART, PIC³² logo, rPIC and UNI/O are registered trademarks of Microchip Technology Incorporated in the U.S.A. and other countries.

FilterLab, Hampshire, HI-TECH C, Linear Active Thermistor, MXDEV, MXLAB, SEEVAL and The Embedded Control Solutions Company are registered trademarks of Microchip Technology Incorporated in the U.S.A.

Analog-for-the-Digital Age, Application Maestro, CodeGuard, dsPICDEM, dsPICDEM.net, dsPICworks, dsSPEAK, ECAN, ECONOMONITOR, FanSense, HI-TIDE, In-Circuit Serial Programming, ICSP, Mindi, MiWi, MPASM, MPLAB Certified logo, MPLIB, MPLINK, mTouch, Omniscient Code Generation, PICC, PICC-18, PICDEM, PICDEM.net, PICKit, PICtail, REAL ICE, rLAB, Select Mode, Total Endurance, TSHARC, UniWinDriver, WiperLock and ZENA are trademarks of Microchip Technology Incorporated in the U.S.A. and other countries.

SQTP is a service mark of Microchip Technology Incorporated in the U.S.A.

All other trademarks mentioned herein are property of their respective companies.

© 2011, Microchip Technology Incorporated, Printed in the U.S.A., All Rights Reserved.

 Printed on recycled paper.

ISBN: 978-1-61341-153-7

Microchip received ISO/TS-16949:2002 certification for its worldwide headquarters, design and wafer fabrication facilities in Chandler and Tempe, Arizona; Gresham, Oregon and design centers in California and India. The Company's quality system processes and procedures are for its PIC[®] MCUs and dsPIC[®] DSCs, KEELOQ[®] code hopping devices, Serial EEPROMs, microperipherals, nonvolatile memory and analog products. In addition, Microchip's quality system for the design and manufacture of development systems is ISO 9001:2000 certified.

**QUALITY MANAGEMENT SYSTEM
CERTIFIED BY DNV
== ISO/TS 16949:2002 ==**

Table of Contents

Preface	5
Introduction.....	5
Document Layout	5
Conventions Used in this Guide	6
Recommended Reading.....	7
The Microchip Web Site	7
Customer Support	7
Document Revision History	7
Chapter 1. Product Overview	
1.1 Introduction	9
1.2 MCP16301 Short Overview	9
1.3 What is the MCP16301 600 mA Demo Board?	10
1.4 MCP16301 600 mA Demo Board Kit Contents	10
Chapter 2. Installation and Operation	
2.1 Introduction	11
2.2 Getting Started	12
Appendix A. Schematic and Layouts	
A.1 Introduction	13
A.2 Board – Schematic	14
A.3 Board – Top Silk And Pads	15
A.4 Board – Top Copper And Pads	15
A.5 Board – Bottom Copper	16
Appendix B. Bill of Materials	
Worldwide Sales and Service	18

NOTES:

Preface

NOTICE TO CUSTOMERS

All documentation becomes dated, and this manual is no exception. Microchip tools and documentation are constantly evolving to meet customer needs, so some actual dialogs and/or tool descriptions may differ from those in this document. Please refer to our web site (www.microchip.com) to obtain the latest documentation available.

Documents are identified with a “DS” number. This number is located on the bottom of each page, in front of the page number. The numbering convention for the DS number is “DSXXXXA”, where “XXXX” is the document number and “A” is the revision level of the document.

For the most up-to-date information on development tools, see the MPLAB® IDE on-line help. Select the Help menu, and then Topics to open a list of available on-line help files.

INTRODUCTION

This chapter contains general information that will be useful to know before using the MCP16301 600 mA Demo Board. Items discussed in this chapter include:

- Document Layout
- Conventions Used in this Guide
- Recommended Reading
- The Microchip Web Site
- Customer Support
- Document Revision History

DOCUMENT LAYOUT

This document describes how to use the MCP16301 600 mA Demo Board as a development tool to emulate and debug firmware on a target board. The manual layout is as follows:

- **Chapter 1. “Product Overview”** – Important information about the MCP16301 600 mA Demo Board.
- **Chapter 2. “Installation and Operation”** – Includes instructions on how to get started with MCP16301 600 mA Demo Board and a description of the user's guide.
- **Appendix A. “Schematic and Layouts”** – Shows the schematic and layout diagrams for the MCP16301 600 mA Demo Board.
- **Appendix B. “Bill of Materials”** – Lists the parts used to build the MCP16301 600 mA Demo Board.

CONVENTIONS USED IN THIS GUIDE

This manual uses the following documentation conventions:

DOCUMENTATION CONVENTIONS

Description	Represents	Examples
Arial font:		
Italic characters	Referenced books	<i>MPLAB[®] IDE User's Guide</i>
	Emphasized text	...is the <i>only</i> compiler...
Initial caps	A window	the Output window
	A dialog	the Settings dialog
	A menu selection	select Enable Programmer
Quotes	A field name in a window or dialog	"Save project before build"
Underlined, italic text with right angle bracket	A menu path	<u><i>File>Save</i></u>
Bold characters	A dialog button	Click OK
	A tab	Click the Power tab
N'Rnnnn	A number in verilog format, where N is the total number of digits, R is the radix and n is a digit.	4'b0010, 2'hF1
Text in angle brackets < >	A key on the keyboard	Press <Enter>, <F1>
Courier New font:		
Plain Courier New	Sample source code	#define START
	Filenames	autoexec.bat
	File paths	c:\mcc18\h
	Keywords	_asm, _endasm, static
	Command-line options	-Opa+, -Opa-
	Bit values	0, 1
	Constants	0xFF, 'A'
Italic Courier New	A variable argument	<i>file.o</i> , where <i>file</i> can be any valid filename
Square brackets []	Optional arguments	mcc18 [options] <i>file</i> [options]
Curly brackets and pipe character: { }	Choice of mutually exclusive arguments; an OR selection	errorlevel {0 1}
Ellipses...	Replaces repeated text	var_name [, var_name...]
	Represents code supplied by user	void main (void) { ... }

RECOMMENDED READING

This user's guide describes how to use MCP16301 600 mA Demo Board. Other useful documents are listed below. The following Microchip documents are available and recommended as supplemental reference resources.

MCP16301 Data Sheet – “*High Voltage Input Integrated Switch Step-Down Regulator*” (DS25004)

MCP16301 300 mA D2PAK Demo Board User's Guide (DS51983)

AN1385, Dynamic Analysis of the MCP16301 Switch Mode Power Converter Utilizing the MCP16301 Design Analyzer (DS01385)

THE MICROCHIP WEB SITE

Microchip provides online support via our web site at www.microchip.com. This web site is used as a means to make files and information easily available to customers. Accessible by using your favorite Internet browser, the web site contains the following information:

- **Product Support** – Data sheets and errata, application notes and sample programs, design resources, user's guides and hardware support documents, latest software releases and archived software
- **General Technical Support** – Frequently Asked Questions (FAQs), technical support requests, online discussion groups, Microchip consultant program member listing
- **Business of Microchip** – Product selector and ordering guides, latest Microchip press releases, listing of seminars and events, listings of Microchip sales offices, distributors and factory representatives

CUSTOMER SUPPORT

Users of Microchip products can receive assistance through several channels:

- Distributor or Representative
- Local Sales Office
- Field Application Engineer (FAE)
- Technical Support

Customers should contact their distributor, representative or field application engineer (FAE) for support. Local sales offices are also available to help customers. A listing of sales offices and locations is included in the back of this document.

Technical support is available through the web site at: <http://support.microchip.com>.

DOCUMENT REVISION HISTORY

Revision A (May 2011)

Initial release of this document.

NOTES:

Chapter 1. Product Overview

1.1 INTRODUCTION

This chapter provides an overview of the MCP16301 600 mA Demo Board and covers the following topics:

- MCP16301 Short Overview
- What is the MCP16301 600 mA Demo Board?
- MCP16301 600 mA Demo Board Kit Contents

1.2 MCP16301 SHORT OVERVIEW

The MCP16301 is a highly integrated, high-efficiency, fixed frequency, step-down DC-DC converter in a popular 6-pin SOT23 package that operates from input voltage sources up to 30V. Integrated features include a high-side switch, fixed-frequency peak-current mode control, internal compensation, peak current limit and over-temperature protection. Minimal external components are necessary to develop a complete step-down DC-DC converter power supply.

High converter efficiency is achieved by integrating the current limited, low resistance, high-speed N-Channel MOSFET and associated drive circuitry. High switching frequency minimizes the size of external filtering components resulting in a small solution size.

The MCP16301 can supply 600 mA of continuous current while regulating the output voltage from 2.0V to 15V. An integrated high performance peak-current mode architecture keeps the output voltage tightly regulated, even during input voltage steps and output current transient conditions that are common in power systems.

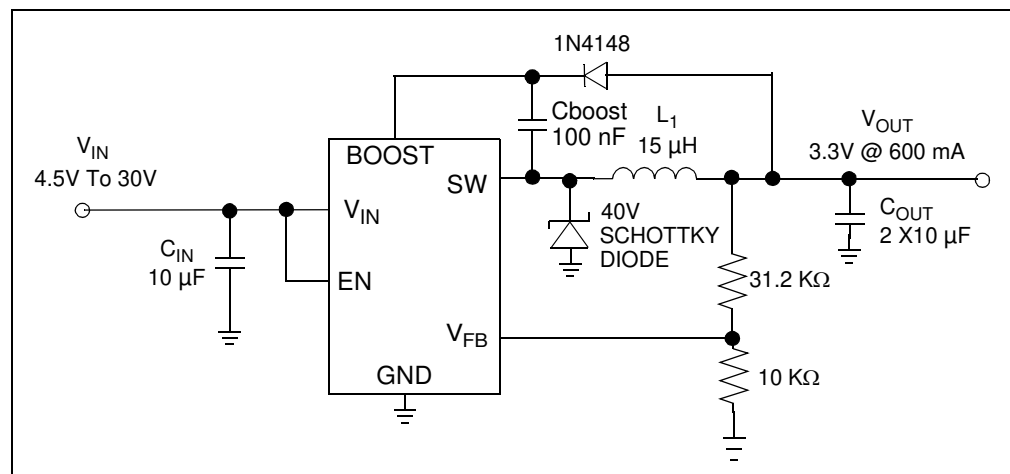

FIGURE 1-1: Typical MCP16301 Step Down Application.

1.3 WHAT IS THE MCP16301 600 mA DEMO BOARD?

The MCP16301 600 mA Demo Board is designed to operate from a 4V to 30V input and regulate the output to 3.3V while delivering 600 mA of load current. Test points for input power and load are provided to demonstrate the capability of the demo board over the entire range. The MCP16301 600 mA Demo Board was designed using small surface-mount components to show application size for a high voltage 600 mA design.

1.4 MCP16301 600 mA DEMO BOARD KIT CONTENTS

This MCP16301 600 mA Demo Board kit includes the following items:

- MCP16301 600 mA Demo Board, 102-00352
- Important Information Sheet

Chapter 2. Installation and Operation

2.1 INTRODUCTION

2.1.1 MCP16301 Features

The MCP16301 device has been developed to provide high input voltage applications with a precise low voltage regulated rail while operating at high efficiency.

The key features of the MCP16301 include:

- Up to 96% Typical Efficiency
- Input Voltage Range: 4.0V to 30V
- Output Voltage Range: 2.0V to 15V
- 2% Output Voltage Accuracy
- Integrated N-Channel Buck Switch: 460 mΩ
- 600 mA Output Current
- 500 kHz Fixed Frequency
- Adjustable Output Voltage
- Low Device Shutdown Current
- Peak Current Mode Control
- Internal Compensation
- Stable with Ceramic Capacitors
- Internal Soft-Start
- Cycle by Cycle Peak Current Limit
- Under Voltage Lockout (UVLO): 3.5V
- Overtemperature Protection
- Available Package: SOT23 - 6

A high performance peak-current mode control system is used to deliver fast response to sudden line and load changes.

2.1.2 MCP16301 600 mA Demo Board Features

The MCP16301 600 mA Demo Board is developed to demonstrate how the MCP16301 device operates over a wide input voltage and load range. Test points are provided for input and output, allowing the demo board to be connected directly to a system.

A copper via connected to the EN input can be used to turn the MCP16301 on and off – turning the device on (EN > 1.4V) when the undervoltage lockout threshold is met (VIN > 3.5V), will enable the device.

2.2 GETTING STARTED

The MCP16301 600 mA Demo Board is fully assembled and tested to evaluate and demonstrate the MCP16301.

2.2.1 Power Input and Output Connection

2.2.1.1 POWERING THE MCP16301 600 mA DEMO BOARD

The MCP16301 600 mA Demo Board is fully assembled, tested and ready to begin evaluation. Apply positive input voltage to the V_{IN} terminal and its return to the GND terminal. The maximum input voltage should not exceed 30V. An electronic load or resistive load can be used for evaluation or the intended system load can be connected. Electronic loads attempt to sink current at 0V during startup, a resistive load or constant resistance is recommended for startup evaluation. Connect the positive voltage terminal of the load to the V_{OUT} terminal on the demo board and connect the negative or return side of the load to the GND terminal.

2.2.1.2 BOARD TESTING

To test the board, follow the next steps:

1. Apply input voltage.
2. An internal pull up resistor is connected from V_{IN} to the EN input of the MCP16301, once the input voltage is greater than 3.5V the device will begin to switch. Apply greater than 4V to the input for proper operation, a minimum load is required to regulate the output to 3.3V. Detailed information is provided in the MCP16301 data sheet (DS25004) for minimum load requirements for light load conditions.
3. The measured output voltage should be 3.3V typical, adjusting the input voltage and load should not cause the output to vary more than a few mV over the operating range of the converter.

2.2.2 How the MCP16301 High Side Drive Boost Circuit Operates

The MCP16301 integrates a low resistance N-Channel MOSFET. A high side or floating supply is needed to drive the gate of the N-Channel MOSFET above the input voltage to turn it on. The demo board uses the output voltage, 3.3V, to charge the boost cap while inductor current flows clamping the SW node to a diode drop below ground. Prior to startup, there is no inductor current, so an internal pre-charge circuit charges the boost cap up to a minimum threshold. Once charged, the N-Channel can be turned on, ramping current into the inductor.

The worst case operating conditions for charging the boost capacitor occur at minimum V_{IN} and no load. At minimum V_{IN} (4V), there is not enough head room to pre-charge the boost cap to a high value. At no load, the converter is operating at a minimum, or very low duty cycle, putting a small amount of current into the inductor. When the switch turns off, the inductor current decays very quickly, resulting in a short time to recharge the boost capacitor.



MCP16301 600 mA DEMO BOARD USER'S GUIDE

Appendix A. Schematic and Layouts

A.1 INTRODUCTION

This appendix contains the following schematics and layouts for the MCP16301 600 mA Demo Board:

- Board – Schematic
- Board – Top Silk And Pads
- Board – Top Copper And Pads
- Board – Bottom Copper

A.2 BOARD – SCHEMATIC

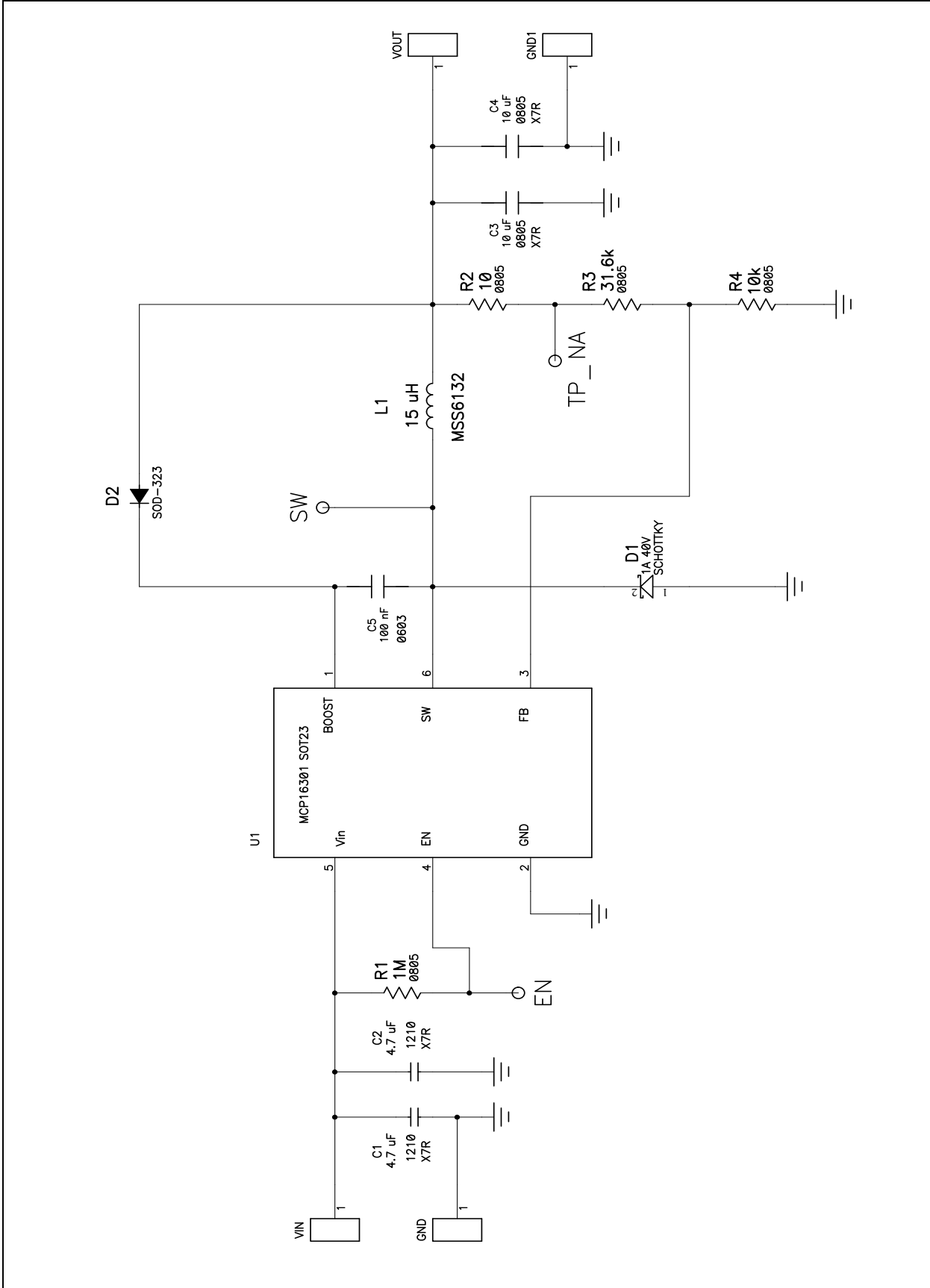

A.3 BOARD – TOP SILK AND PADS

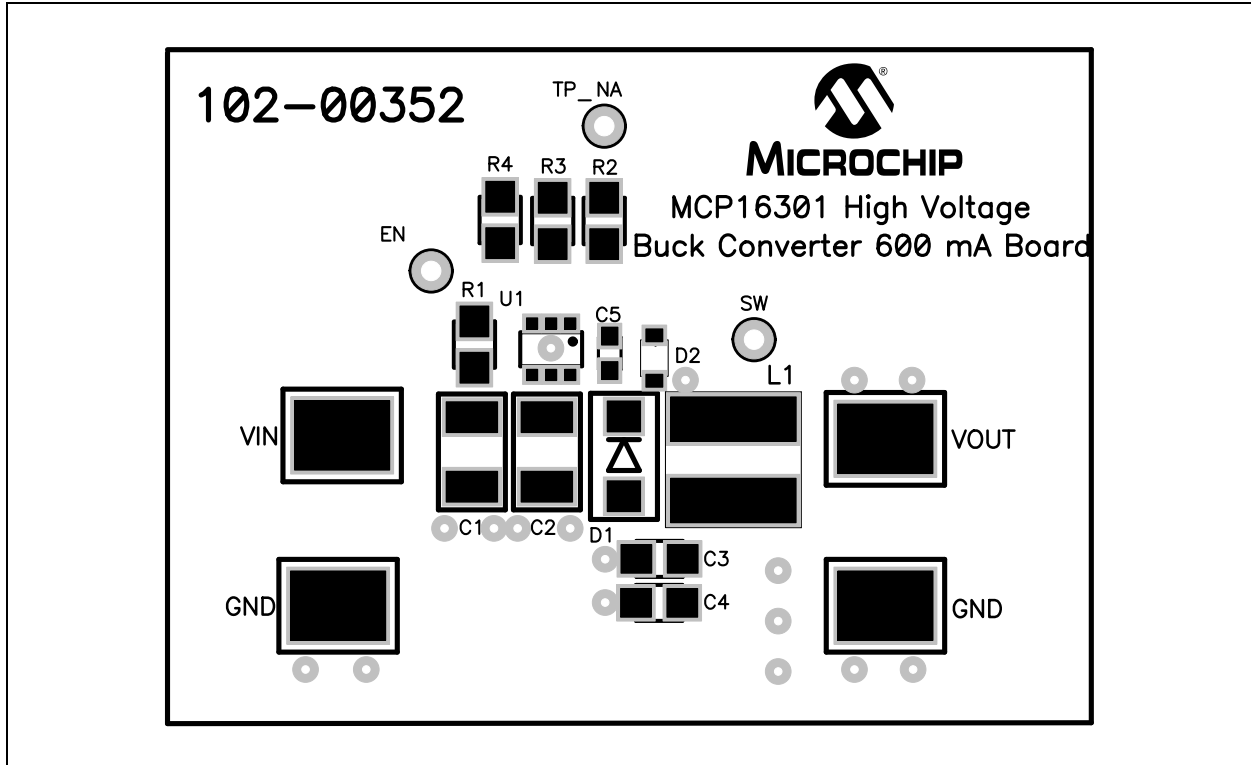

A.4 BOARD – TOP COPPER AND PADS

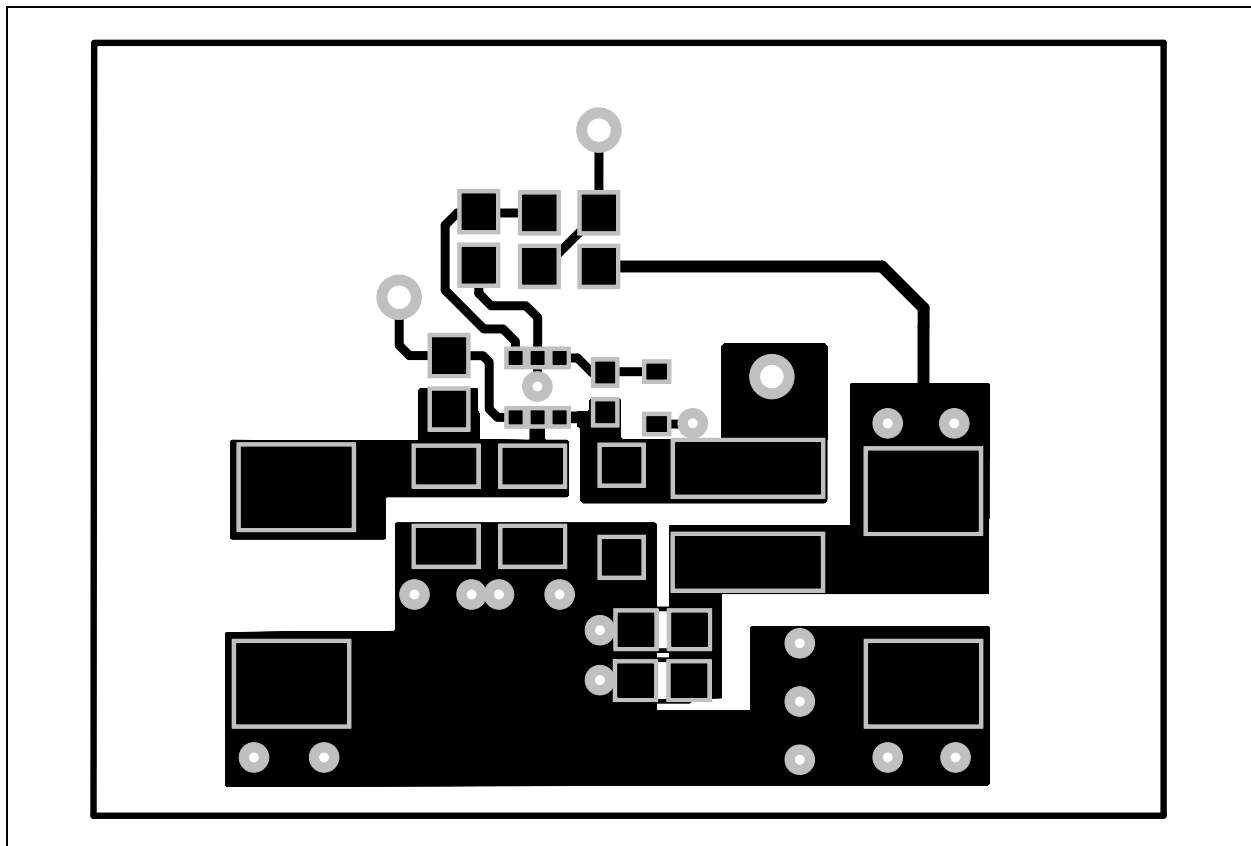

A.5 BOARD – BOTTOM COPPER

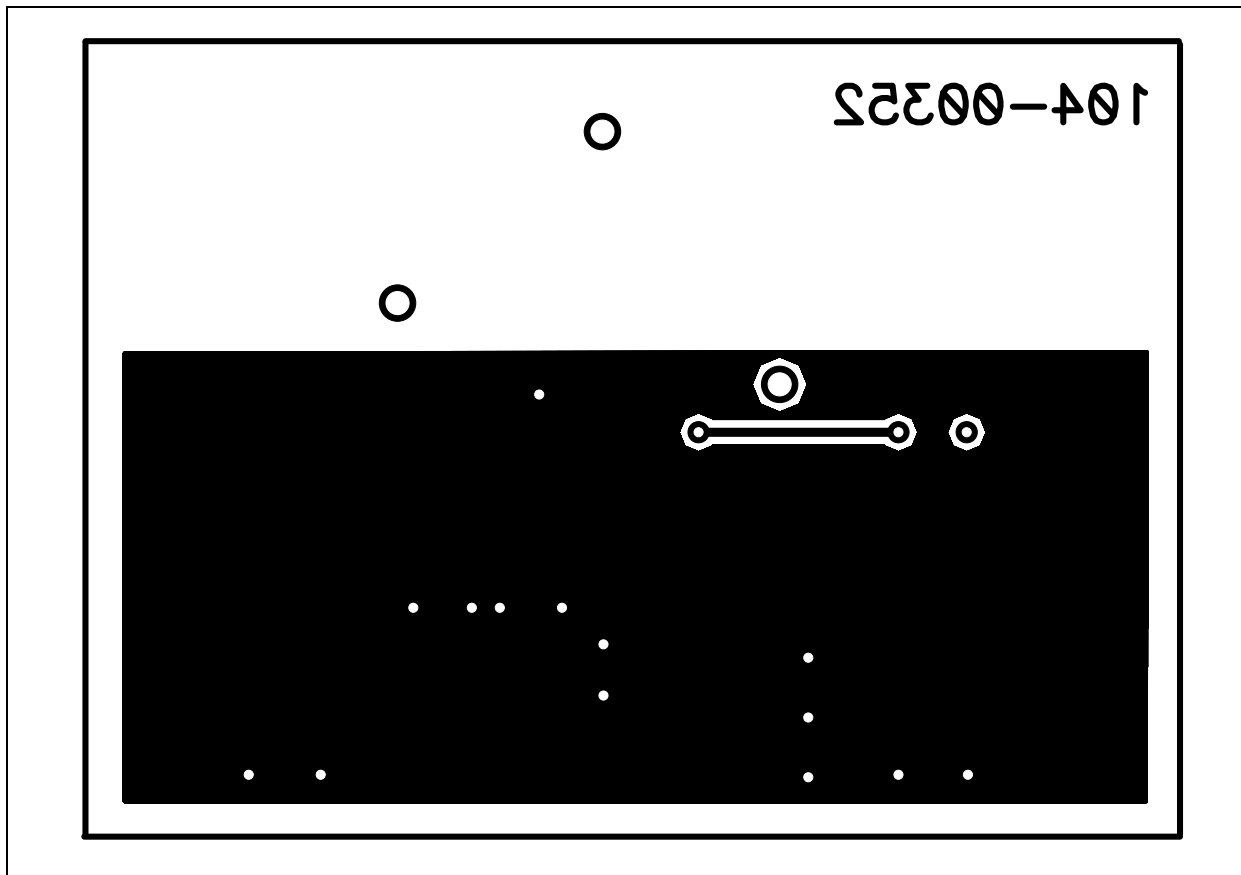

Appendix B. Bill of Materials

TABLE B-1: BILL OF MATERIALS (BOM)

Qty	Reference	Description	Manufacturer	Part Number
4	BUMP	BUMPON Square 0.40" x 0.1" Black	3M™	SJ-5007 (Black)
2	C1, C2	CAP 4.7uF 50V CERAMIC X7R 1210 10%	Taiyo Yuden®	UMK325B7475KM-T
2	C3, C4	CAP 10uF 6.3V CERAMIC X7R 0805 10%	Taiyo Yuden	JMK212B7106KG-T
1	C5	CAP 0.1uF 16V CERAMIC X7R 0603 10%	AVX Corporation	0603YC104KAT2A
1	D1	DIODE SCHOTTKY 40V 1A SMA	Diodes Incorporated®	B140-13-F
1	D2	DIODE SWITCH 75V 200 mW SOD-323	Diodes Incorporated	1N4448WS-7-F
1	L1	MSS6132 15 µH Shielded Power Inductor	Coilcraft®	MSS6132-153ML
1	PCB	MCP16301 4V to 30V V _{IN} , 3.3V 600 mA I _{OUT} Printed Circuit Board	Microchip Technology Inc.	104-00352
1	R1	RES 1.00M OHM 1/8W 1% 0805 SMD	Panasonic® ECG	ERJ-6ENF1004V
1	R2	RES 10 OHM 1/8W 1% 0805 SMD	Panasonic ECG	ERJ-6ENF10R0V
1	R3	RES 31.6K OHM 1/8W 1% 0805 SMD	Panasonic ECG	ERJ-6ENF3162V
1	R4	RES 10.0K OHM 1/8W 1% 0805 SMD	Panasonic ECG	ERJ-6ENF1002V
1	U1	MCP16301 High Input Voltage Buck Converter SOT23	Microchip Technology Inc.	MCP16301
4	VIN, VOUT, GND, GND	PC TEST POINT TIN SMD	Harwin	S1751-46R

Note 1: The components listed in this Bill of Materials are representative of the PCB assembly. The released BOM used in manufacturing uses all RoHS-compliant components.



MICROCHIP

Worldwide Sales and Service

AMERICAS

Corporate Office
2355 West Chandler Blvd.
Chandler, AZ 85224-6199
Tel: 480-792-7200
Fax: 480-792-7277
Technical Support:
<http://www.microchip.com/support>
Web Address:
www.microchip.com

Atlanta
Duluth, GA
Tel: 678-957-9614
Fax: 678-957-1455

Boston
Westborough, MA
Tel: 774-760-0087
Fax: 774-760-0088

Chicago
Itasca, IL
Tel: 630-285-0071
Fax: 630-285-0075

Cleveland
Independence, OH
Tel: 216-447-0464
Fax: 216-447-0643

Dallas
Addison, TX
Tel: 972-818-7423
Fax: 972-818-2924

Detroit
Farmington Hills, MI
Tel: 248-538-2250
Fax: 248-538-2260

Indianapolis
Noblesville, IN
Tel: 317-773-8323
Fax: 317-773-5453

Los Angeles
Mission Viejo, CA
Tel: 949-462-9523
Fax: 949-462-9608

Santa Clara
Santa Clara, CA
Tel: 408-961-6444
Fax: 408-961-6445

Toronto
Mississauga, Ontario,
Canada
Tel: 905-673-0699
Fax: 905-673-6509

ASIA/PACIFIC

Asia Pacific Office
Suites 3707-14, 37th Floor
Tower 6, The Gateway
Harbour City, Kowloon
Hong Kong
Tel: 852-2401-1200
Fax: 852-2401-3431

Australia - Sydney
Tel: 61-2-9868-6733
Fax: 61-2-9868-6755

China - Beijing
Tel: 86-10-8569-7000
Fax: 86-10-8528-2104

China - Chengdu
Tel: 86-28-8665-5511
Fax: 86-28-8665-7889

China - Chongqing
Tel: 86-23-8980-9588
Fax: 86-23-8980-9500

China - Hangzhou
Tel: 86-571-2819-3180
Fax: 86-571-2819-3189

China - Hong Kong SAR
Tel: 852-2401-1200
Fax: 852-2401-3431

China - Nanjing
Tel: 86-25-8473-2460
Fax: 86-25-8473-2470

China - Qingdao
Tel: 86-532-8502-7355
Fax: 86-532-8502-7205

China - Shanghai
Tel: 86-21-5407-5533
Fax: 86-21-5407-5066

China - Shenyang
Tel: 86-24-2334-2829
Fax: 86-24-2334-2393

China - Shenzhen
Tel: 86-755-8203-2660
Fax: 86-755-8203-1760

China - Wuhan
Tel: 86-27-5980-5300
Fax: 86-27-5980-5118

China - Xian
Tel: 86-29-8833-7252
Fax: 86-29-8833-7256

China - Xiamen
Tel: 86-592-2388138
Fax: 86-592-2388130

China - Zhuhai
Tel: 86-756-3210040
Fax: 86-756-3210049

ASIA/PACIFIC

India - Bangalore
Tel: 91-80-3090-4444
Fax: 91-80-3090-4123

India - New Delhi
Tel: 91-11-4160-8631
Fax: 91-11-4160-8632

India - Pune
Tel: 91-20-2566-1512
Fax: 91-20-2566-1513

Japan - Yokohama
Tel: 81-45-471- 6166
Fax: 81-45-471-6122

Korea - Daegu
Tel: 82-53-744-4301
Fax: 82-53-744-4302

Korea - Seoul
Tel: 82-2-554-7200
Fax: 82-2-558-5932 or
82-2-558-5934

Malaysia - Kuala Lumpur
Tel: 60-3-6201-9857
Fax: 60-3-6201-9859

Malaysia - Penang
Tel: 60-4-227-8870
Fax: 60-4-227-4068

Philippines - Manila
Tel: 63-2-634-9065
Fax: 63-2-634-9069

Singapore
Tel: 65-6334-8870
Fax: 65-6334-8850

Taiwan - Hsin Chu
Tel: 886-3-6578-300
Fax: 886-3-6578-370

Taiwan - Kaohsiung
Tel: 886-7-213-7830
Fax: 886-7-330-9305

Taiwan - Taipei
Tel: 886-2-2500-6610
Fax: 886-2-2508-0102

Thailand - Bangkok
Tel: 66-2-694-1351
Fax: 66-2-694-1350

EUROPE

Austria - Wels
Tel: 43-7242-2244-39
Fax: 43-7242-2244-393

Denmark - Copenhagen
Tel: 45-4450-2828
Fax: 45-4485-2829

France - Paris
Tel: 33-1-69-53-63-20
Fax: 33-1-69-30-90-79

Germany - Munich
Tel: 49-89-627-144-0
Fax: 49-89-627-144-44

Italy - Milan
Tel: 39-0331-742611
Fax: 39-0331-466781

Netherlands - Drunen
Tel: 31-416-690399
Fax: 31-416-690340

Spain - Madrid
Tel: 34-91-708-08-90
Fax: 34-91-708-08-91

UK - Wokingham
Tel: 44-118-921-5869
Fax: 44-118-921-5820

05/02/11