

P-Channel Trench Power MOSFET

General Description

The G18P03S uses advanced trench technology to provide excellent $R_{DS(ON)}$, low gate charge and operation with gate voltages as low as -5V. This device is suitable for use as a wide variety of applications.

Features

●

V_{DS}	$R_{DS(ON)}$ @-4.5V(TYP)	$R_{DS(ON)}$ @-10V(TYP)	I_D
-30V	10.5m Ω	8.1m Ω	-15A

- High Power and current handling capability
- RoHS Compliant
- Surface Mount Package

Application

- DC-DC converter
- Load switch
- Power management

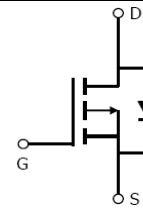

Schematic Diagram

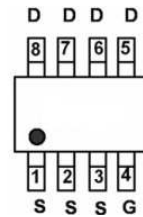

Marking and pin assignment



SOP-8

Ordering Information

Part Number	Marking	Case	Packaging
G18P03S	G18P03	SOP-8	4000pcs/Reel

Table 1. Absolute Maximum Ratings ($T_A=25^{\circ}C$)

Symbol	Parameter	Value	Unit
V_{DS}	Drain-Source Voltage ($V_{GS}=0V$)	-30	V
V_{GS}	Gate-Source Voltage ($V_{DS}=0V$)	± 20	V
I_D	Drain Current-Continuous($T_C=25^{\circ}C$)	-15	A
$I_{DM (pluse)}$	Drain Current-Continuous@ Current-Pulsed (Note 1)	-60	A
P_D	Maximum Power Dissipation($T_C=25^{\circ}C$)	3.1	W
T_J, T_{STG}	Operating Junction and Storage Temperature Range	-55 To 150	$^{\circ}C$

Table 2. Thermal Characteristic

Symbol	Parameter	Typ	Max	Unit
$R_{\theta JC}$	Thermal Resistance, Junction-to-Case	--	40	$^{\circ}C/W$

Table 3. Electrical Characteristics (TA=25°C unless otherwise noted)

Symbol	Parameter	Conditions	Min	Typ	Max	Unit
On/Off States						
BV _{DSS}	Drain-Source Breakdown Voltage	V _{GS} =0V I _D =-250μA	-30			V
I _{DSS}	Zero Gate Voltage Drain Current	V _{DS} =-30V, V _{GS} =0V			-1	μA
I _{GSS}	Gate-Body Leakage Current	V _{GS} =±20V, V _{DS} =0V			±100	nA
V _{GS(th)}	Gate Threshold Voltage	V _{DS} =V _{GS} , I _D =-250μA	-1.1	-1.6	-2.5	V
g _{FS}	Forward Transconductance	V _{DS} =-5V, I _D =-10A		28		S
R _{DS(ON)}	Drain-Source On-State Resistance	V _{GS} =-10V, I _D =-10A		8.1	10	mΩ
		V _{GS} =-4.5V, I _D =-6 A		10.5	15	mΩ
Dynamic Characteristics						
C _{iss}	Input Capacitance	V _{DS} =-15V, V _{GS} =0V, f=1.0MHz		3570		pF
C _{oss}	Output Capacitance			435		pF
C _{rss}	Reverse Transfer Capacitance			175		pF
Switching Times						
t _{d(on)}	Turn-on Delay Time	V _{DD} =-15V, I _D =-1A, R _L =15Ω V _{GS} =-10V, R _G =2.5Ω		16		nS
t _r	Turn-on Rise Time			14		nS
t _{d(off)}	Turn-Off Delay Time			50		nS
t _f	Turn-Off Fall Time			22		nS
Q _g	Total Gate Charge	V _{GS} =-10V, V _{DS} =-15V, I _D =-10A		58		nC
Q _{gs}	Gate-Source Charge			9		nC
Q _{gd}	Gate-Drain Charge			14		nC
Source-Drain Diode Characteristics						
I _S	Source-Drain Current(Body Diode)				-15	A
V _{SD}	Forward on Voltage	V _{GS} =0V, I _S =-10A			-1.2	V

Notes 1.Repetitive Rating: Pulse width limited by maximum junction temperature

Switch Time Test Circuit and Switching Waveforms:

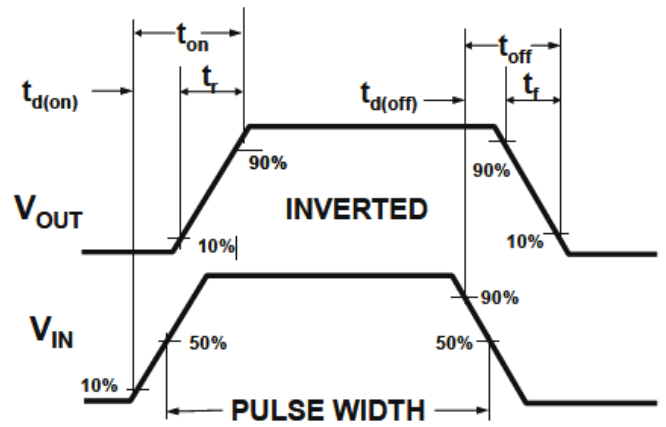
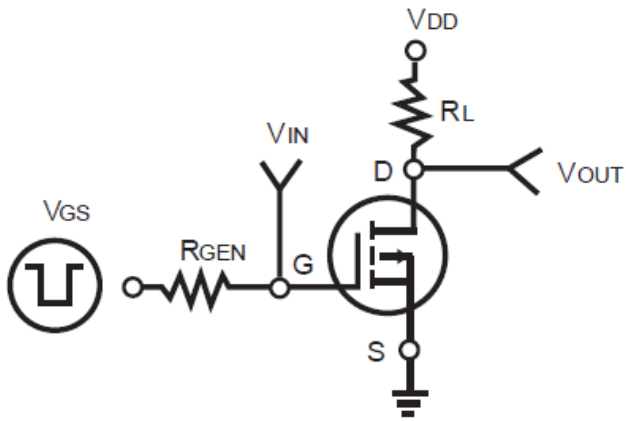

TYPICAL ELECTRICAL AND THERMAL CHARACTERISTICS (Curves)

Figure1. Power Dissipation

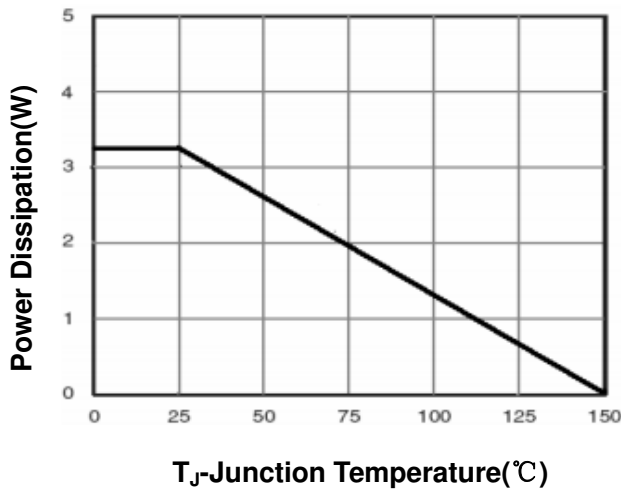

Figure2. Transfer Characteristics

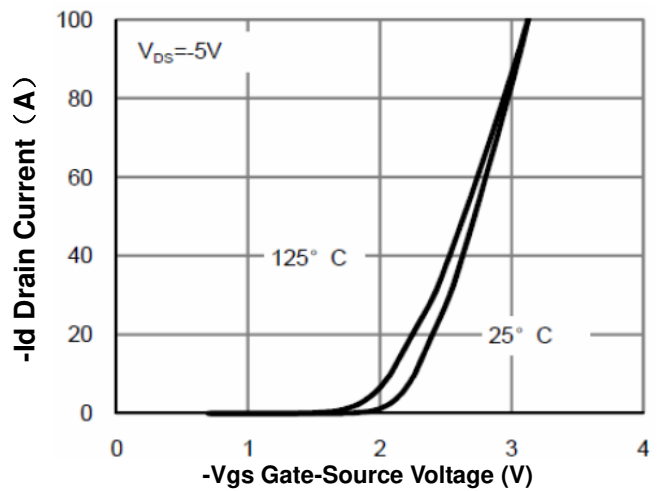

Figure3. Output Characteristics

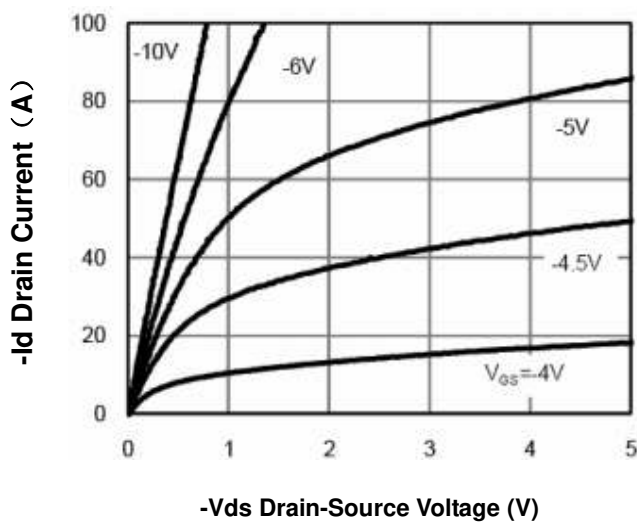

Figure 4. $R_{DS(on)}$ Drain Current

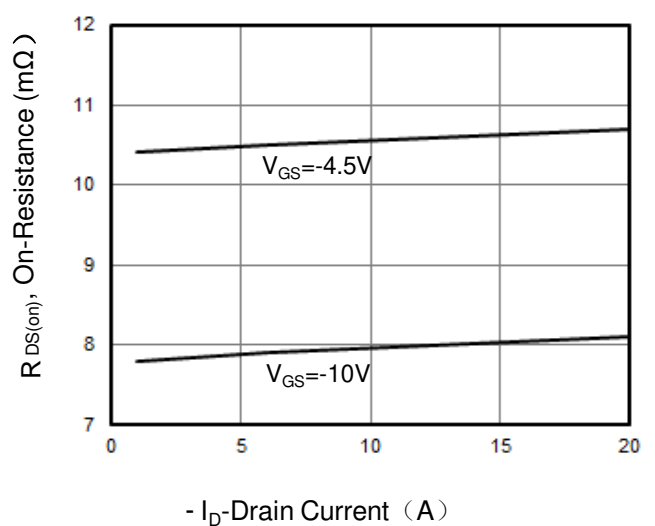

Figure5. Capacitance

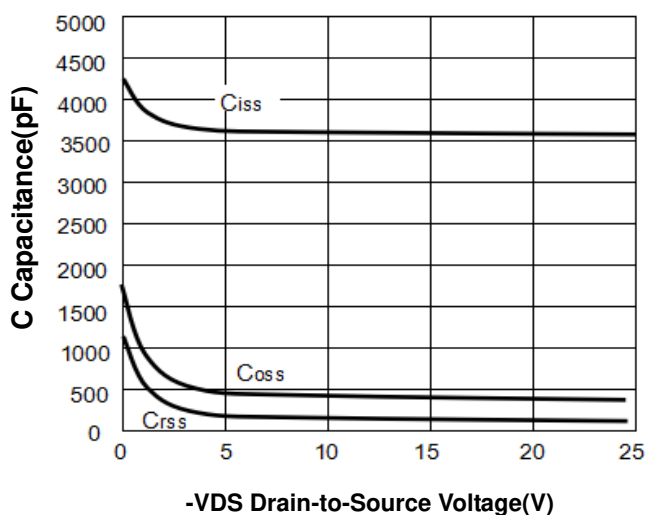

Figure6. $R_{DS(ON)}$ vs Junction Temperature

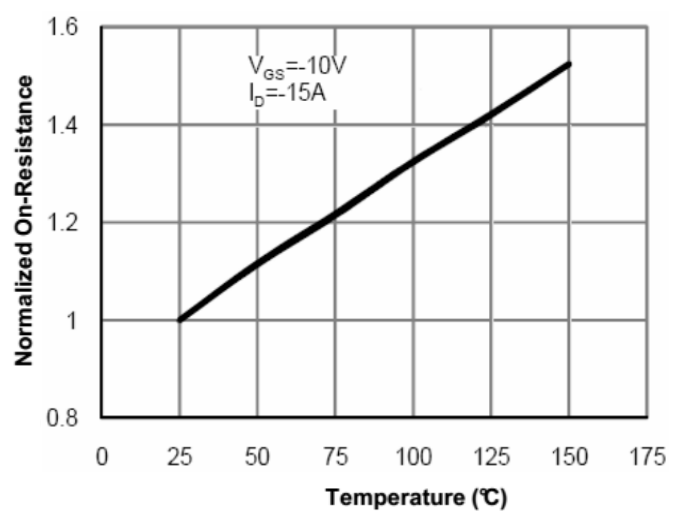

Figure7. Gate Charge Waveforms

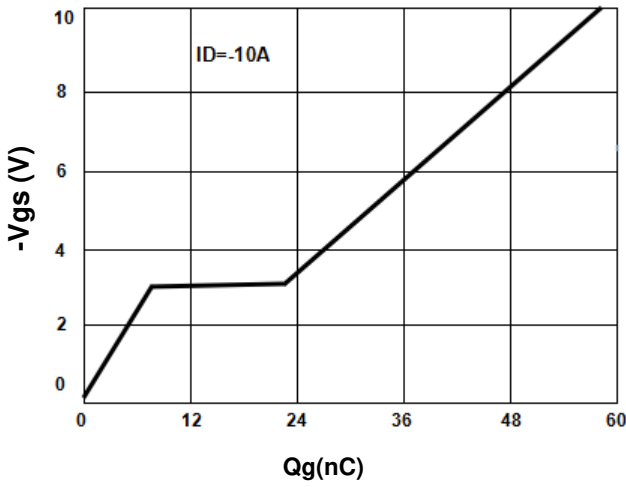

Figure8. Maximum Safe Operating Area

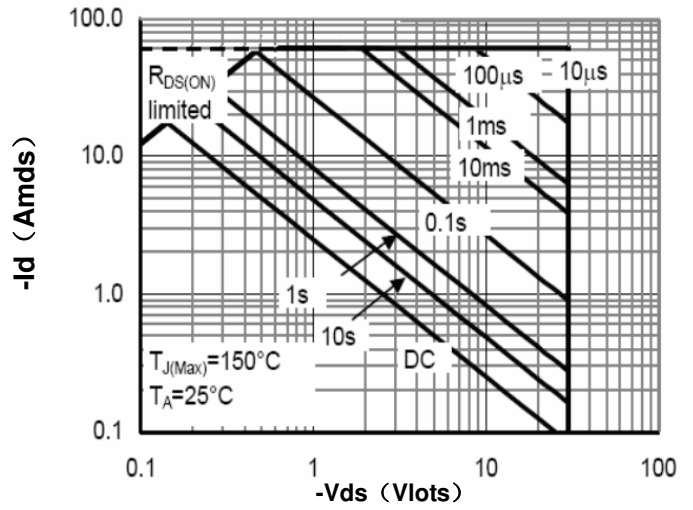
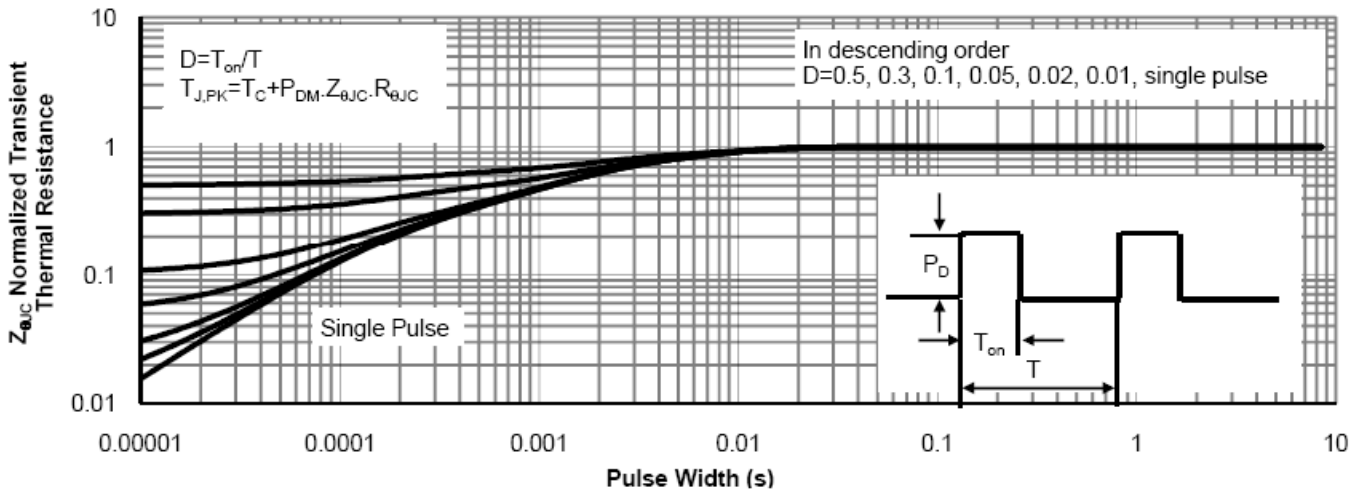
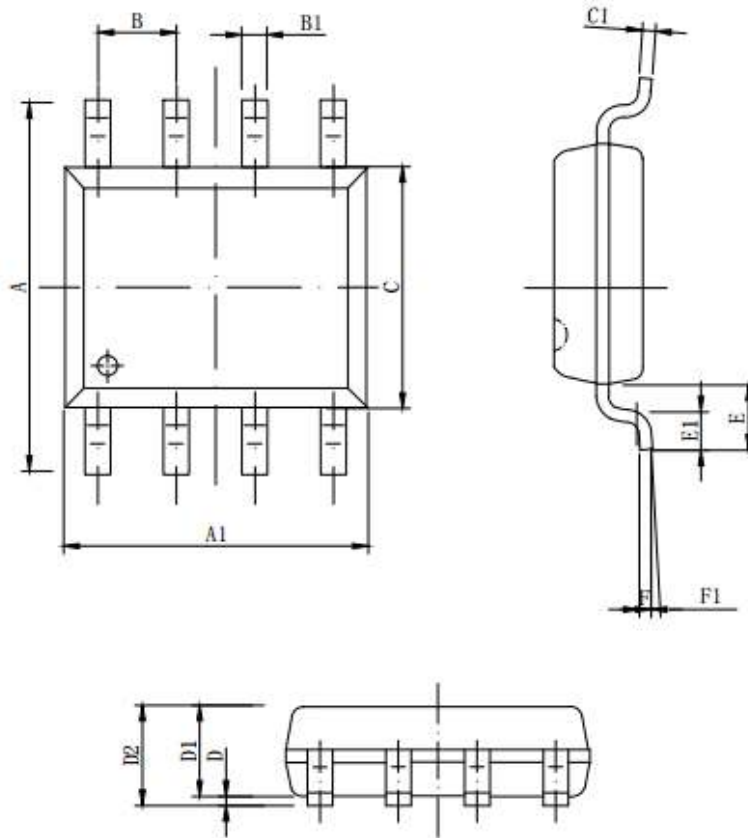

Figure9. Normalized Maximum Transient Thermal Impedance



SOP-8 Package Information



Symbol	Dimensions in Millimeters		
	MIN.	NOM.	MAX.
A	5.800	6.000	6.200
A1	4.800	4.900	5.000
B	1.270BSC		
B1	0.35 ⁸ x	0.40 ⁸ x	0.45 ⁸ x
C	3.780	3.880	3.980
C1	--	0.203	0.253
D	0.050	0.150	0.250
D1	1.350	1.450	1.550
D2	1.500	1.600	1.700
D2	1.500	1.600	1.700
E	1.060REF		
E1	0.400	0.700	0.100
F	0.250BSC		
F1	2°	4°	6°