

| REVISIONS | | | | | |
|-----------|-----|---------------------|---------|-----|-------|
| REV | ECO | DESCRIPTION | DATE | BY | APPR |
| A1 | -- | RELEASE NEW DRAWING | 08MAY20 | IAN | TOMMY |
| A2 | -- | MODIFY PRODUCT NAME | 11AUG20 | IAN | TOMMY |

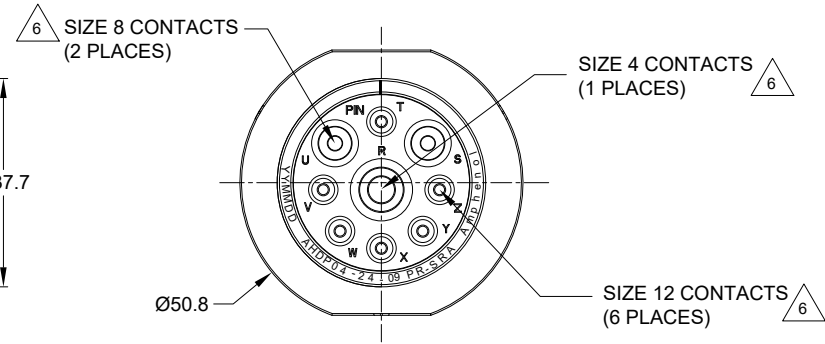

NOTES: UNLESS OTHERWISE SPECIFIED

- MATERIAL:
HOUSING: THERMOPLASTIC; BLACK
SEAL: SILICONE RUBBER
- MODIFICATIONS: SMOOTH RING ADAPTER (SRA);
REDUCED DIA. WIRE SEAL.
- SPECIFICATIONS:
3.1 OPERATING TEMPERATURE: -55°C TO +125°C.
3.2 DIELECTRIC WITHSTANDING VOLTAGE: LESS THAN 2 MILLIAMPS CURRENT LEAKAGE @ 1500 VOLTS AC.
3.3 INSULATION RESISTANCE: 1000 MEGOHM MIN @ 25°C.
3.4 MOISTURE RESISTANCE: IP67&IP69K (MATED CONDITION).
3.5 MATING CYCLE DURABILITY: 100 CYCLES
3.6 RoHS COMPLIANT
- MATING PART: AHDP06-24-09S* (* = SEAL TYPE)
- ALL DIMENSIONS ARE FOR REFERENCE USE ONLY.

1 11/16-18 UNEF THREAD

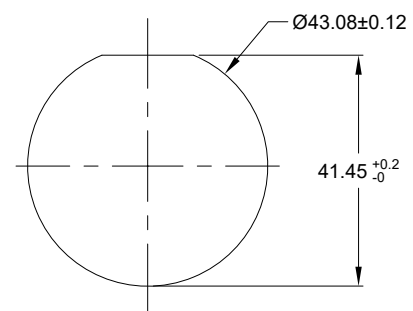

RECOMMENDED PANEL MOUNTING HOLE
RECOMMENDED PANEL THICKNESS: 1.6 TO 4.7MM

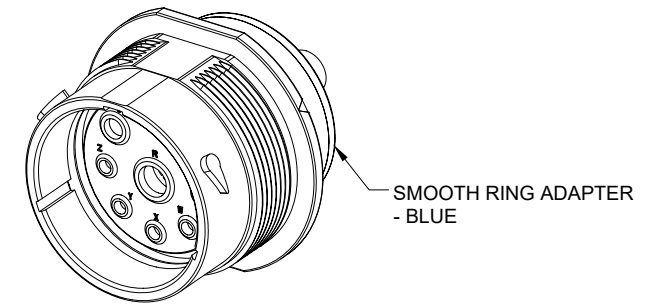

CONTACT SIZE AND WIRE RANGE:

| CONTACT SIZE | MIN. INSUL O.D. | MAX. INSUL O.D. | TYPICAL WIRE RANGE | CURRENT RATING |
|--------------|-------------------|-------------------|-------------------------------------|----------------|
| 4 | 6.63 mm (.261 in) | 7.42 mm (.292 in) | 6 AWG (16.0-13.0mm ²) | 100 AMPS |
| 8 | 3.43 mm (.135 in) | 5.59 mm (.220 in) | 8-10 AWG (10.0-5.0mm ²) | 60 AMPS |
| 12 | 2.46 mm (.097 in) | 4.01 mm (.158 in) | 10-14 AWG (6.0-2.0mm ²) | 25 AMPS |

7. RECEPTACLE IS SUPPLIED WITH DUST CAP.

| | | | |
|--|----------------|--|---------------------------------|
| AHDP04-24-09PR-SRA | | REF:HDP24-24-9PE | |
| PART NUMBER | | DESCRIPTION | |
| QUANTITY | MATERIALS LIST | | |
| UNLESS OTHERWISE SPECIFIED: 1) All dimensions are in metric (mm). 2) Tolerances are as follows: 1 PL DEC ±0.30 2 PL DEC ±0.15 3 PL DEC ±0.08 Fractions ±1/64 Angles ±1° | | | |
| SIGNATURES | | DATE | |
| DRAWN: WAN XIAO | | 11AUG20 | |
| CHECKED: ORION LI | | 12AUG20 | |
| ENGINEER: | | | |
| APPROVAL: TOMMY XIE | | 13AUG20 | |
| MATERIAL SPECIFICATIONS: | | CUSTOMER: | |
| PROCESS SPECIFICATIONS: | | THIS DRAWING IS SUPPLIED FOR INFORMATION ONLY. DESIGN FEATURES, SPECIFICATIONS AND PERFORMANCE DATA SHOWN HEREON ARE THE PROPERTY OF THE AMPHENOL CORPORATION. NO RIGHTS OF REPRODUCTION ARE IMPLIED. ALL DIMENSIONS ARE SUBJECT TO NORMAL MANUFACTURING VARIATIONS. | |
| NEXT ASSY: | | SIZE: B C- | TYPE: AHDP04-24-09PR-SRA |
| | | SCALE: NONE | DURAMATE |
| | | SHEET 1 | OF 1 |

Amphenol
Sine Systems - www.amphenol-sine.com
44724 Morley Drive
Clinton Township, MI 48036

RECEPT., SIZE 24, 9-PIN,
RD01 SEAL, SRA, DURAMATE AHDP SERIES

REVISION: **A2**

TITLE: RECEPT. SIZE 24, 9-PIN, RD01 SEAL, SRA, DURAMATE AHDP SERIES
DWG NO: AHDP04-24-09PR-SRA
REV: A2
SH: 1
OF: 1

MagnaMate™ ATHP - DuraMate™ AHDP - DuraMate™ AHDM Series - Contact Size 12 Options



| Machined Contacts, Sockets & Pins | | | | |
|-----------------------------------|--|------|-------|----------|
| Part Number | Description | Size | AWG | Type |
| AT60-204-12141-10 | Male Contact - Pin, Nickel-plated | 12 | 10-12 | Machined |
| AT62-203-12141-10 | Female Contact - Socket, Nickel-plated | 12 | 10-12 | Machined |
| AT60-220-1231 | Male Contact - Pin, Gold-plated | 12 | 12-14 | Machined |
| AT62-210-1231 | Female Contact - Socket, Gold-plated | 12 | 12-14 | Machined |
| AT60-204-12141 | Male Contact - Pin, Nickel-plated | 12 | 12-14 | Machined |
| AT62-203-12141 | Female Contact - Socket, Nickel-plated | 12 | 12-14 | Machined |

| DiagnosticGrade™ Machined Contacts, Sockets & Pins | | | | |
|--|--|------|-----|----------|
| • Smaller AWG for Diagnostic Applications • Gold-plated • Increased Mating Cycles • Cost-effective | | | | |
| Part Number | Description | Size | AWG | Type |
| 65-54749 | Male Contact - DiagnosticGrade™, Pin, Gold-plated | 12 | 20 | Machined |
| AT62-210-1231-1820 | Female Contact - DiagnosticGrade™, Socket, Gold-plated | 12 | 20 | Machined |

| Tooling - Machined Contacts | | |
|---|-------------|---|
| Part | Part Number | Description |
|  | CA-5D12 | Universal Hand Crimp Tool, Size 12/16/20 (Machined contacts only) |
|  | CA-5E12 | Pneumatic Crimp Tool, Size 12/16/20 (Machined contacts only) |

| Contact Removal Tools | | |
|---|---------------|--|
| Part | Part Number | Description |
|  | AT11-337-1205 | Contact Removal Tool, Plastic, Size 12 |
|  | A114017 | Sealing Plug, Size 12, White |





| Stamped & Formed Contacts, Sockets & Pins | | | | |
|---|--|------|-------|------------------|
| Part Number | Description | Size | AWG | Type |
| AT60-12-0244 | Male Contact - Pin, Gold-plated | 12 | 10-12 | Stamped & Formed |
| AT62-12-0244 | Female Contact - Socket, Gold-plated | 12 | 10-12 | Stamped & Formed |
| AT60-12-0222 | Male Contact - Pin, Nickel-plated | 12 | 10-12 | Stamped & Formed |
| AT62-12-0222 | Female Contact - Socket, Nickel-plated | 12 | 10-12 | Stamped & Formed |
| AT60-12-0144 | Male Contact - Pin, Gold-plated | 12 | 12-14 | Stamped & Formed |
| AT62-12-0144 | Female Contact - Socket, Gold-plated | 12 | 12-14 | Stamped & Formed |
| AT60-12-0166 | Male Contact - Pin, Nickel-plated | 12 | 12-14 | Stamped & Formed |
| AT62-12-0166 | Female Contact - Socket, Nickel-plated | 12 | 12-14 | Stamped & Formed |

| Tooling - Stamped & Formed Contacts | | |
|---|-------------|---|
| Part | Part Number | Description |
|  | MFX-3973 | Crimp Die - Size 12 (S&F contacts only) |
| | MFX-3985 | Crimp Die - Size 12 (S&F contacts only) 10-12AWG -02XX Series |
|  | ATT-12-00 | Hand Crimp Tool - Size 12, 12AWG (S&F contacts only) |
| | ATT-12-01 | Hand Crimp Tool - Size 12, 10AWG (S&F contacts only) |

Amphenol Sine Systems
 44724 Morley Drive
 Clinton Township, MI 48036 USA
www.amphenol-sine.com
 01/2022

DuraMate™ ATHD Series™ - Contact Size 8 Options





| Machined Contacts, Pins and Sockets | | | | | |
|-------------------------------------|--|------|------|----------|------|
| Part Number | Description | Size | AWG | Type | Amps |
| AT60-204-08141 | Male Contact - Pin, Copper Alloy, Nickel-Plated | 8 | 8-10 | Machined | 60A |
| AT62-203-08141 | Female Contact - Socket, Copper Alloy, Nickel-Plated | 8 | 8-10 | Machined | 60A |

| Tooling - Machined Contacts | | |
|---|-------------|--|
| Part | Part Number | Description |
|  | WA23 | Heavy Duty Pneumatic Crimp Tool -Uses Universal Positioner Part No. WA23-101DA and Crimp Locator MFX-3961 |
|  | WA23-2 | Die Assembly -for CA-5E12 Heavy Duty Pneumatic Crimp Tool, Size 8 |
|  | WA23-10 | Contact Locator, Size 8 |
|  | 96-978-22 | Crimper and Dies -for Size 10mm ² -185mm ² Wires |

| Contact Removal Tools | | |
|---|-------------|--|
| Part | Part Number | Description |
|  | AT114008 | Contact Removal Tool, Plastic, Size 8, 8-10AWG |

DuraMate™ ATHD Series™ - Contact Size 4 Options

| Machined Contacts, Pins and Sockets | | | | | |
|-------------------------------------|--|------|-----|----------|------|
| Part Number | Description | Size | AWG | Type | Amps |
| AT60-203-04141-4 | Male Contact - Pin, Copper Alloy, Nickel-Plated | 4 | 4 | Machined | 100A |
| AT60-204-0490 | Male Contact - Pin, Copper Alloy, Nickel-Plated | 4 | 6 | Machined | 100A |
| AT62-203-04141-4 | Female Contact - Socket, Copper Alloy, Nickel-Plated | 4 | 4 | Machined | 100A |
| AT62-203-04141 | Female Contact - Socket, Copper Alloy, Nickel-Plated | 4 | 6 | Machined | 100A |

| Tooling - Machined Contacts | | |
|---|-------------|--|
| Part | Part Number | Description |
|  | WA23 | Heavy Duty Pneumatic Crimp Tool -Uses Universal Positioner Part No. WA23-101DA and Crimp Locator MFX-3961 |
|  | WA23-138DA | Die Assembly -for Heavy Duty Pneumatic Crimp Tool, Size 4 |
|  | WA23-11 | Contact Locator, Size 4 |
|  | 96-978-22 | Crimper and Dies -for Size 10mm ² -185mm ² Wires |

| Contact Removal Tools | | |
|---|---------------|---|
| Part | Part Number | Description |
|  | AT11-027-0405 | Contact Removal Tool, Plastic, Size 4, 4AWG |