

10 9 8 7 6 5 4 3 2 1

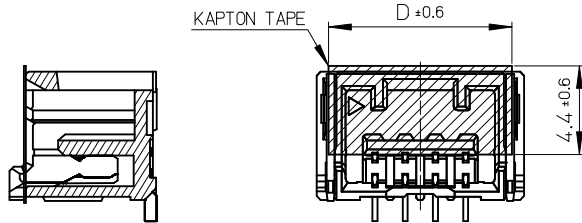

SECTION Z-Z

2~7極カプトンテープ形状
KAPTON TEPE FIGURE OF 2-7 CIRCUIT

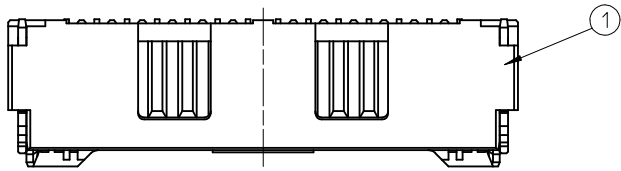
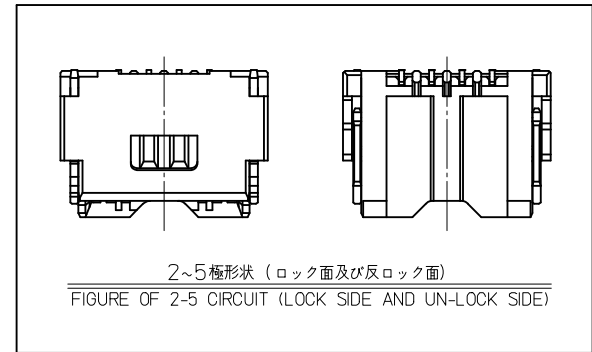

2~5極形状 (ロック面及び反ロック面)
FIGURE OF 2-5 CIRCUIT (LOCK SIDE AND UN-LOCK SIDE)

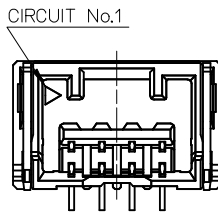
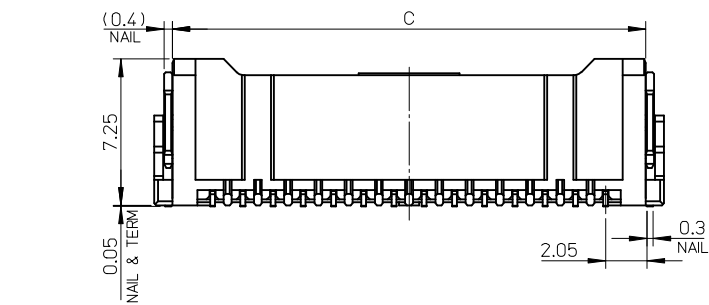
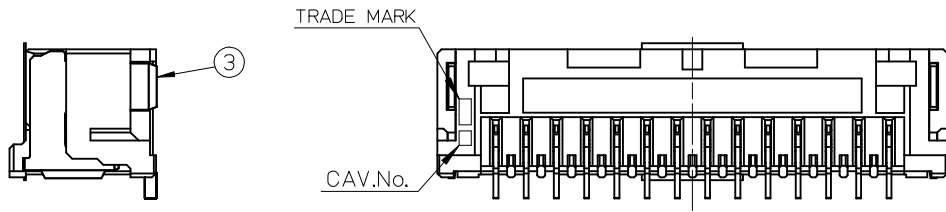
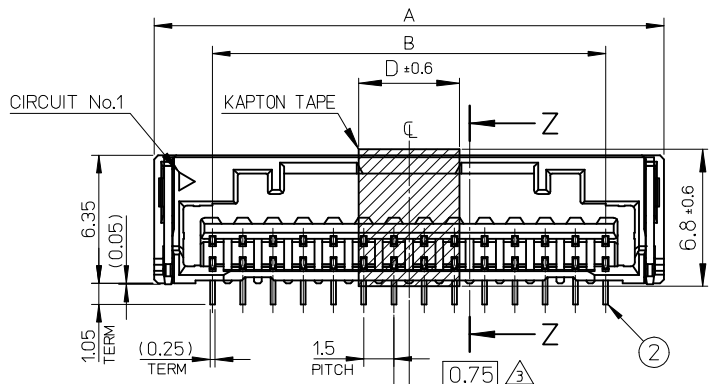

2~5 極の場合
CASE OF 2-5 CIRCUIT

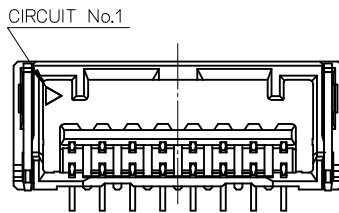

6~11 極の場合
CASE OF 6-11 CIRCUIT

5	25	21	26.8	502584 -156*	15
5	23.5	19.5	25.3	-146*	14
5	22	18	23.8	-136*	13
5	20.5	16.5	22.3	-126*	12
5	19	15	20.8	-116*	11
5	17.5	13.5	19.3	-106*	10
5	16	12	17.8	-096*	9
5	14.5	10.5	16.3	-086*	8
13.6	13	9	14.8	-076*	7
12.1	11.5	7.5	13.3	-066*	6
10.6	10	6	11.8	-056*	5
9.1	8.5	4.5	10.3	-046*	4
7.6	7	3	8.8	-036*	3
6.1	5.5	1.5	7.3	502584 -026*	2
D	C	B	A	EMBOSSD TAPE PACKAGE 注文番号 ORDER No.	CIRCUIT No.

No.	部品 PART	材料 MATERIAL
①	ハウジング HOUSING	耐熱性樹脂 UL94V-0 HEATPROOF RESIN UL94V-0
②	ターミナル TERMINAL	銅合金 COPPER ALLOY
		錫めっき: 1.0 micro-meter MIN. TIN (TAIL AREA) ニッケルめっき(下地): 1.0 micro-meter MIN. NICKEL (UNDER PLATING)
③	ネイル NAIL	銅合金 COPPER ALLOY
		錫めっき: 1.0 micro-meter MIN. TIN ニッケルめっき(下地): 1.0 micro-meter MIN. NICKEL (UNDER PLATING)

REVISED EC NO: J2013-1045 DRWN: NITO 2013/03/25 CHKD: KASAKAWA 2013/03/25 APPR: Y01TO 2013/03/26	DESCRIPTION	GENERAL TOLERANCES (UNLESS SPECIFIED)		DIMENSION STYLE MM ONLY		SCALE 4:1	DESIGN UNITS METRIC		THIRD ANGLE PROJECTION	
		10 UNDER	±0.2	DRAWN BY NITO		DATE 2008/07/03	TITLE 1.5 MM W/B CONN. S/T REC. ASSY WITH KAPTON TAPE			
		10 OVER 30 UNDER	±0.25	CHECKED BY KASAKAWA		DATE 2008/07/03				
		30 OVER	±0.3	APPROVED BY SICHIKAWA		DATE 2008/07/03				
ANGULAR ±1 °		DRAFT WHERE APPLICABLE MUST REMAIN WITHIN DIMENSIONS		MATERIAL NO. SEE TABLE		DOCUMENT NO. SD-502584-003		SHEET NO. 1 OF 3		
THIS DRAWING CONTAINS INFORMATION THAT IS PROPRIETARY TO MOLEX INCORPORATED AND SHOULD NOT BE USED WITHOUT WRITTEN PERMISSION										

9 8 7 6 5 4 3 2

NOTES

1. 嵌合相手 : 502578
MATE WITH : 502578 SERIES
2. 端子テール部及びネイルの平坦度 : 0.1 MAX.
TAIL AND NAIL COPLANARITY TO BE 0.1 MAX.
3. 極数/2 = 偶数に適用
APPLY FOR CIRCUIT SIZE / 2 = EVEN
4. 端子テール部及びネイルに錫めっきを使用している為、
外観に摺動痕が付く場合があります。
THE WOUND OF FRICTION MIGHT ADHERE TO EXTERNALS
BECAUSE THE TIN PLATING IS USED FOR THE TAIL AND NAIL.
5. 製品番号
MATERIAL No.

502584-***

極数 ↑
CIRCUIT SIZE

色 ↑
COLOR

No.	COLOR	CIRCUIT
60	ベージュ BEIGE	2~15
61	黒 BLACK	
62	赤 RED	
63	黄 YELLOW	
64	青 BLUE	
65	桃 PINK	
66	緑 GREEN	
67	茶 BROWN	
68	橙 ORANGE	
69	紫 VIOLET	

6. 本製品のプラスチック部に黒点・白点等が確認される場合や
色合いが異なる場合がありますが、製品性能に影響はありません。
THERE IS NO INFLUENCE IN THE PRODUCT
PERFORMANCE THOUGH THE BLACK AND WHITE SPOT ETC.
MIGHT BE CONFIRMED TO THE PLASTIC PART OF
THIS PRODUCT AND THE SHADE MIGHT BE DIFFERENT.
7. ELV 及び RoHS 適合品
ELV AND RoHS COMPLIANT
8. ORDER No. AND CONNECTOR SERIES No.

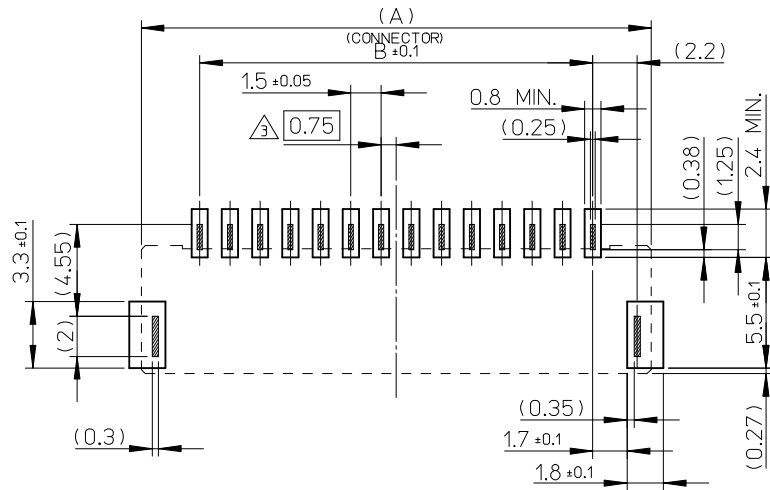

基板パターンレイアウト (参考)
RECOMMENDED P.C.B PATTERN LAYOUT (REF.)

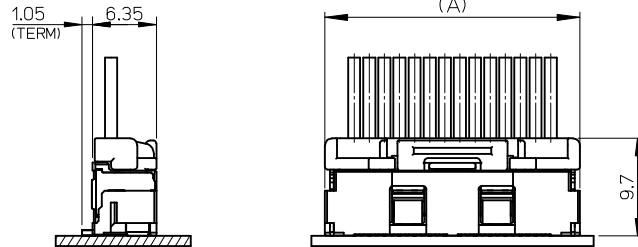

嵌合図
MATED CONNECTORES

REVISED EC NO.: J2013-1045 DRWN: NITO 2013/03/25 CHKD: KASAKAWA 2013/03/25 APPR: YONITO 2013/03/26	GENERAL TOLERANCES (UNLESS SPECIFIED)		DIMENSION STYLE MM ONLY		SCALE 4:1	DESIGN UNITS METRIC	THIRD ANGLE PROJECTION
	10 UNDER	±0.2	DRAWN BY NITO	DATE 2008/07/03	TITLE 1.5 MM W/B CONN. S/T REC. ASSY WITH KAPTON TAPE		
	10 OVER 30 UNDER	±0.25	CHECKED BY KASAKAWA	DATE 2008/07/03			
	30 OVER	±0.3	APPROVED BY SICHIKAWA	DATE 2008/07/03			
ANGULAR ±1 °		MATERIAL NO. SEE TABLE		DOCUMENT NO. SD-502584-003		SHEET NO. 2 OF 3	
DRAFT WHERE APPLICABLE MUST REMAIN WITHIN DIMENSIONS		THIS DRAWING CONTAINS INFORMATION THAT IS PROPRIETARY TO MOLEX INCORPORATED AND SHOULD NOT BE USED WITHOUT WRITTEN PERMISSION					

△ ORDER No. AND CONNECTOR SERIES No.

HSG COLOR : BLUE		HSG COLOR : YELLOW		HSG COLOR : RED		HSG COLOR : BLACK		HSG COLOR : BEIGE		
502584-1564	502584-**64	502584-1563	502584-**63	502584-1562	502584-**62	502584-1561	502584-**61	502584-1560	502584-**60	15
502584-1464		502584-1463		502584-1462		502584-1461		502584-1460		14
502584-1364		502584-1363		502584-1362		502584-1361		502584-1360		13
502584-1264		502584-1263		502584-1262		502584-1261		502584-1260		12
502584-1164		502584-1163		502584-1162		502584-1161		502584-1160		11
502584-1064		502584-1063		502584-1062		502584-1061		502584-1060		10
502584-0964		502584-0963		502584-0962		502584-0961		502584-0960		9
502584-0864		502584-0863		502584-0862		502584-0861		502584-0860		8
502584-0764		502584-0763		502584-0762		502584-0761		502584-0760		7
502584-0664		502584-0663		502584-0662		502584-0661		502584-0660		6
502584-0564		502584-0563		502584-0562		502584-0561		502584-0560		5
502584-0464		502584-0463		502584-0462		502584-0461		502584-0460		4
502584-0364		502584-0363		502584-0362		502584-0361		502584-0360		3
502584-0264		502584-0263		502584-0262		502584-0261		502584-0260		2
EMBOSSED TAPE PACKAGE オーダー番号ORDER No.	コネクタシリーズ CONNECTOR SERIES	EMBOSSED TAPE PACKAGE オーダー番号ORDER No.	コネクタシリーズ CONNECTOR SERIES	EMBOSSED TAPE PACKAGE オーダー番号ORDER No.	コネクタシリーズ CONNECTOR SERIES	EMBOSSED TAPE PACKAGE オーダー番号ORDER No.	コネクタシリーズ CONNECTOR SERIES	EMBOSSED TAPE PACKAGE オーダー番号ORDER No.	コネクタシリーズ CONNECTOR SERIES	極数 (Ckt. No.)

HSG COLOR : VIOLET		HSG COLOR : ORANGE		HSG COLOR : BROWN		HSG COLOR : GREEN		HSG COLOR : PINK		
502584-1569	502584-**69	502584-1568	502584-**68	502584-1567	502584-**67	502584-1566	502584-**66	502584-1565	502584-**65	15
502584-1469		502584-1468		502584-1467		502584-1466		502584-1465		14
502584-1369		502584-1368		502584-1367		502584-1366		502584-1365		13
502584-1269		502584-1268		502584-1267		502584-1266		502584-1265		12
502584-1169		502584-1163		502584-1167		502584-1166		502584-1165		11
502584-1069		502584-1068		502584-1067		502584-1066		502584-1065		10
502584-0969		502584-0968		502584-0967		502584-0966		502584-0965		9
502584-0869		502584-0868		502584-0867		502584-0866		502584-0865		8
502584-0769		502584-0768		502584-0767		502584-0766		502584-0765		7
502584-0669		502584-0668		502584-0667		502584-0666		502584-0665		6
502584-0569		502584-0568		502584-0567		502584-0566		502584-0565		5
502584-0469		502584-0468		502584-0467		502584-0466		502584-0465		4
502584-0369		502584-0368		502584-0367		502584-0366		502584-0365		3
502584-0269		502584-0268		502584-0267		502584-0266		502584-0265		2
EMBOSSED TAPE PACKAGE オーダー番号ORDER No.	コネクタシリーズ CONNECTOR SERIES	EMBOSSED TAPE PACKAGE オーダー番号ORDER No.	コネクタシリーズ CONNECTOR SERIES	EMBOSSED TAPE PACKAGE オーダー番号ORDER No.	コネクタシリーズ CONNECTOR SERIES	EMBOSSED TAPE PACKAGE オーダー番号ORDER No.	コネクタシリーズ CONNECTOR SERIES	EMBOSSED TAPE PACKAGE オーダー番号ORDER No.	コネクタシリーズ CONNECTOR SERIES	極数 (Ckt. No.)

REVISED EC NO: J2013-1045 DRWN: NITO 2013/03/25 CHKD: KASAKAWA 2013/03/25 APPR: Y01ITO 2013/03/26	GENERAL TOLERANCES (UNLESS SPECIFIED)		DIMENSION STYLE MM ONLY		SCALE 4:1	DESIGN UNITS METRIC		THIRD ANGLE PROJECTION	
	10 UNDER	±0.2	DRAWN BY NITO	DATE 2008/07/03	TITLE 1.5 MM W/B CONN. S/T REC. ASSY WITH KAPTON TAPE				
	10 OVER 30 UNDER	±0.25	CHECKED BY KASAKAWA	DATE 2008/07/03	molex				
	30 OVER	±0.3	APPROVED BY SICHIKAWA	DATE 2008/07/03					
ANGULAR ±1 °		MATERIAL NO. SEE TABLE		DOCUMENT NO. SD-502584-003		SHEET NO. 3 OF 3			
DRAFT WHERE APPLICABLE MUST REMAIN WITHIN DIMENSIONS		THIS DRAWING CONTAINS INFORMATION THAT IS PROPRIETARY TO MOLEX INCORPORATED AND SHOULD NOT BE USED WITHOUT WRITTEN PERMISSION							

10 9 8 7 6 5 4 3 2 1

引き出し方向
PULL OUT DIRECTION

REEL

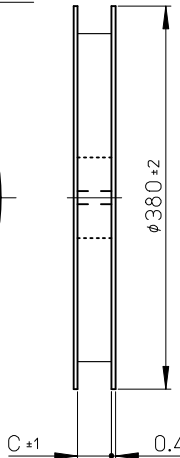
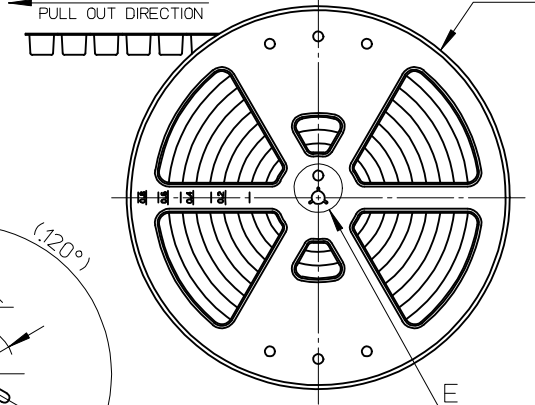

引き出し方向
PULL OUT DIRECTION

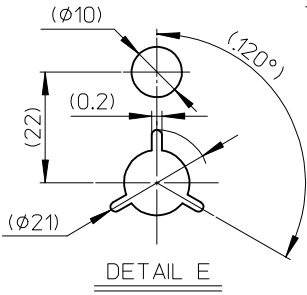
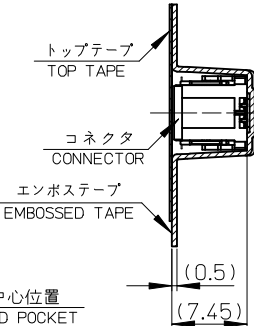
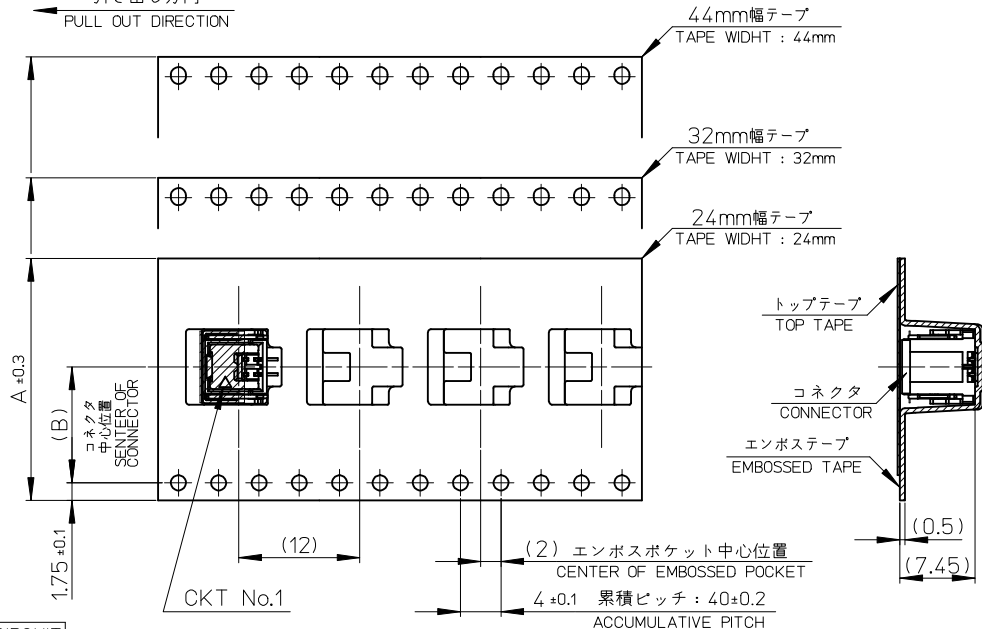

NOTES

- 製品詳細寸法については、SD-502584-003を参照下さい。
PLEASE REFER TO SD-502584-003 FOR THE DETAILED DIMENSION OF THE CONNECTOR.
- 梱包数量：900個
NUMBER OF CONNECTORS：900 PIECES/REEL.
- リードテープ長さ
LEAD TAPE LENGTH

トップテープ接着部(空エンボス)
20 PIECES MIN.
TOP TAPE BONDED PART(EMPTY)

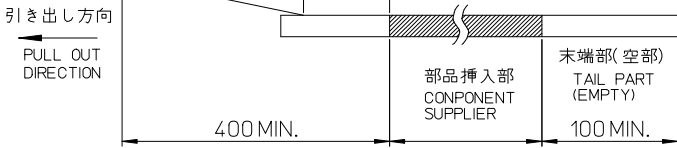

No.	COLOR	CIRCUIT
60	ベージュ BEIGE	2~15
61	黒 BLACK	
62	赤 RED	
63	黄 YELLOW	
64	青 BLUE	
65	桃 PINK	
66	緑 GREEN	
67	茶 BROWN	
68	橙 ORANGE	
69	紫 VIOLET	

△ ORDER No. AND CONNECTOR SERIES No.

- 本製品は乾燥剤入り、ハイバリア梱包仕様である。
THIS PRODUCT IS HIGH BARRIER PACKAGE WITH DESICCANT.

45.5	20.2	44	502584-156*	15
45.5	20.2	44	-146*	14
45.5	20.2	44	-136*	13
45.5	20.2	44	-126*	12
45.5	20.2	44	-116*	11
45.5	20.2	44	-106*	10
33.5	14.2	32	-096*	9
33.5	14.2	32	-086*	8
33.5	14.2	32	-076*	7
33.5	14.2	32	-066*	6
25.5	11.5	24	-056*	5
25.5	11.5	24	-046*	4
25.5	11.5	24	-036*	3
25.5	11.5	24	502584-026*	2

- 材料
MATERIAL
キャリアテープ：ポリスチレン
CARRIER TAPE：POLYSTYRENE
トップテープ：ポリエステル、ポリエチレン、ポリエチレンテレフタレート
TOP TAPE：POLYESTER, POLYETHYLENE, POLYETHYLENE TEREPHTHALATE
リール：ポリスチレン <リサイクル材を含む>
REEL：POLYSTYRENE <RECYCLE MATERIAL CONTAINED>

- ELV及びRoHS適合品
ELV AND RoHS COMPLIANT

△ 製品番号
MATERIAL NO.

502584-****

極数
CIRCUIT SIZE

色
COLOR

REVISED		GENERAL TOLERANCES (UNLESS SPECIFIED)		DIMENSION STYLE		SCALE		DESIGN UNITS	
EC NO.	DATE	DESCRIPTION	10 UNDER	±0.2	MM ONLY	---	METRIC	THIRD ANGLE PROJECTION	
J2010-0624	2009/10/07	DRWN:NITO	10 OVER 30 UNDER	±0.25	DRAWN BY	DATE	TITLE	EMBOSSED TAPE PACKAGE FOR 502584-**** WITH KAPTON TAPE	
	2009/10/07	CHKD:KASAKAWA	30 OVER	±0.3	CHECKED BY	DATE		MOLEX INCORPORATED	
	2009/10/08	APPR:NUKITA	ANGULAR ±1 °		APPROVED BY	DATE		SD-502584-004	
			DRAFT WHERE APPLICABLE MUST REMAIN WITHIN DIMENSIONS		MATERIAL NO.		DOCUMENT NO.	SHEET NO.	
					SIZE	THIS DRAWING CONTAINS INFORMATION THAT IS PROPRIETARY TO MOLEX INCORPORATED AND SHOULD NOT BE USED WITHOUT WRITTEN PERMISSION			1 OF 2

△ ORDER No. AND CONNECTOR SERIES No.

HSG COLOR : BLUE		HSG COLOR : YELLOW		HSG COLOR : RED		HSG COLOR : BLACK		HSG COLOR : BEIGE		
502584-***64	502584-1564	502584-***63	502584-1563	502584-***62	502584-1562	502584-***61	502584-1561	502584-***60	502584-1560	15
	502584-1464		502584-1463		502584-1462		502584-1461		502584-1460	14
	502584-1364		502584-1363		502584-1362		502584-1361		502584-1360	13
	502584-1264		502584-1263		502584-1262		502584-1261		502584-1260	12
	502584-1164		502584-1163		502584-1162		502584-1161		502584-1160	11
	502584-1064		502584-1063		502584-1062		502584-1061		502584-1060	10
	502584-0964		502584-0963		502584-0962		502584-0961		502584-0960	9
	502584-0864		502584-0863		502584-0862		502584-0861		502584-0860	8
	502584-0764		502584-0763		502584-0762		502584-0761		502584-0760	7
	502584-0664		502584-0663		502584-0662		502584-0661		502584-0660	6
	502584-0564		502584-0563		502584-0562		502584-0561		502584-0560	5
	502584-0464		502584-0463		502584-0462		502584-0461		502584-0460	4
	502584-0364		502584-0363		502584-0362		502584-0361		502584-0360	3
	502584-0264		502584-0263		502584-0262		502584-0261		502584-0260	2
コネクタ シリーズ CONNECTOR SERIES	製品番号 MATERIAL NO.	コネクタ シリーズ CONNECTOR SERIES	製品番号 MATERIAL NO.	コネクタ シリーズ CONNECTOR SERIES	製品番号 MATERIAL NO.	コネクタ シリーズ CONNECTOR SERIES	製品番号 MATERIAL NO.	コネクタ シリーズ CONNECTOR SERIES	製品番号 MATERIAL NO.	極数 (K.T. NO.)

HSG COLOR : VIOLET		HSG COLOR : ORANGE		HSG COLOR : BROWN		HSG COLOR : GREEN		HSG COLOR : PINK		
502584-***69	502584-1569	502584-***68	502584-1568	502584-***67	502584-1567	502584-***66	502584-1566	502584-***65	502584-1565	15
	502584-1469		502584-1468		502584-1467		502584-1466		502584-1465	14
	502584-1369		502584-1368		502584-1367		502584-1366		502584-1365	13
	502584-1269		502584-1268		502584-1267		502584-1266		502584-1265	12
	502584-1169		502584-1168		502584-1167		502584-1166		502584-1165	11
	502584-1069		502584-1068		502584-1067		502584-1066		502584-1065	10
	502584-0969		502584-0968		502584-0967		502584-0966		502584-0965	9
	502584-0869		502584-0868		502584-0867		502584-0866		502584-0865	8
	502584-0769		502584-0768		502584-0767		502584-0766		502584-0765	7
	502584-0669		502584-0668		502584-0667		502584-0666		502584-0665	6
	502584-0569		502584-0568		502584-0567		502584-0566		502584-0565	5
	502584-0469		502584-0468		502584-0467		502584-0466		502584-0465	4
	502584-0369		502584-0368		502584-0367		502584-0366		502584-0365	3
	502584-0269		502584-0268		502584-0267		502584-0266		502584-0265	2
コネクタ シリーズ CONNECTOR SERIES	製品番号 MATERIAL NO.	コネクタ シリーズ CONNECTOR SERIES	製品番号 MATERIAL NO.	コネクタ シリーズ CONNECTOR SERIES	製品番号 MATERIAL NO.	コネクタ シリーズ CONNECTOR SERIES	製品番号 MATERIAL NO.	コネクタ シリーズ CONNECTOR SERIES	製品番号 MATERIAL NO.	極数 (K.T. NO.)

REVISED EC NO: J2010-0624 2009/10/07 DRWN: NITO 2009/10/07 CHKD: KASAKAWA 2009/10/07 APPR: NUKITA 2009/10/08	GENERAL TOLERANCES (UNLESS SPECIFIED)		DIMENSION STYLE MM ONLY		SCALE ---	DESIGN UNITS METRIC	THIRD ANGLE PROJECTION	
	10 UNDER	±0.2	DRAWN BY NITO	DATE 2008/07/03	TITLE EMBOSSSED TAPE PACKAGE FOR 502584-**** WITH KAPTON TAPE			
	10 OVER 30 UNDER	±0.25	CHECKED BY KASAKAWA	DATE 2008/07/03	APPROVED BY SICHIKAWA 2008/07/03			
	30 OVER	±0.3	MATERIAL NO.		DOCUMENT NO.		SHEET NO.	
	ANGULAR ±1 ° DRAFT WHERE APPLICABLE MUST REMAIN WITHIN DIMENSIONS		SEE TABLE		SD-502584-004		2 OF 2	