

# Amphenol



## Amphenol

MIL-DTL-26482  
SERIES 2 CONNECTORS  
ACSE206-05-14  
(QPL APPROVED)





## Introduction

This catalog covers the Amphenol MIL-DTL-26482, Series 2 Connectors. These connectors are bayonet coupling type, and they feature crimp contacts that are rear insertable and rear releasable. They can be ordered through Amphenol, by military or equivalent proprietary part numbers.

The connectors covered in this catalog broaden the miniature cylindrical family offered by Amphenol, so that now users have the broadest range of product available to them.

Should more information be required concerning the connectors covered in this publication, or if special application needs arise, please contact factory :

	Page
Introduction	1
General description, features & benefits	2
Class descriptions, performance specifications	3
QPL Certificate	4
Insert Arrangement Chart Insert Alternate Positions	5
Insert Arrangement Patterns	6-8
<b>Shell Styles, Dimensional Data :</b>	
Wall Mounting Receptacle, Narrow Flange	9
Wall Mounting Receptacle Wide Flange	10
Cable Connecting Receptacle	11
Jam Nut Receptacle	12
Straight Plug, Straight Plug With RFI Grounding Fingers	13
Protective Caps	14-15
Dummy Storage Receptacle	16
Backshells	17-25
Contact Information, Sealing Plugs, Crimping & Insertion/Removal Tools	26
Ordering Information	27

## Amphenol Miniature Cylindrical MIL-DTL-26482, Series 2 Connectors



MS 3470  
IMB1-0  
wall mounting receptacle  
with narrow flange



MS 3472  
IMB1-2  
wall mounting receptacle  
with wide flange



MS 3471  
IMB1-1  
cable connecting receptacle



MS 3474  
IMB1-4  
jam nut receptacle



MS 3476  
IMB1-6  
straight plug



MS 3475  
IMB1-5  
plug with RFI grounding  
fingers

### Amphenol broadens their Miniature Cylindrical Family of Connectors with the addition of the product line of MIL-DTL-26482, Series 2 connectors.

This series provides a bayonet coupling connector with crimp rear insertable, rear releasable contacts.

#### DESIGN CHARACTERISTICS

- Medium size, environmentally resistant connector
  - Recommended operating voltage to 1000 VAC (RMS) at sea level
  - Quick positive coupling assured by 3 point bayonet coupling system
  - Visual confirmation of complete coupling
  - Eliminates mismatching by the use of five key/keyway design
  - Insertion and removal of contacts from the rear of the connectors assures no damage to the front that might affect the sealing characteristics
  - Utilizes same standard qualified rear release type plastic tool for contact insertion and removal
  - Contacts are qualified to SAE AS 39029 requirements - BIN coded (three colour bands), and are crimped with standard crimp tools per MIL-C-22520
  - Grommets are constructed of tear-resistant elastomer and experience no degradation when exposed to a broad range of fluids
  - Sealing over a range of wire diameters is assured by a triple webbed grommet at the rear of the connector
  - Closed entry socket side of the insert is designed with a lead-in chamfer and a hard face that will accept a pin contact bent within pre-established limits
  - Elastomer interfacial seal on the pin side has raised barriers around each pin which displace into the socket chamfer when mated, providing a positive moisture seal
- CUSTOMER OPTIONS**  
Shell styles within this family include:
- Wall mount with either a narrow or a wide flange, jam nut single hole mount, and cable connecting receptacles, along with standard plugs or plugs with RFI grounding fingers, in shell sizes 8 to 24
  - MS and Proprietary versions available
  - Accommodation of contact sizes 20, 16 and 12
  - 34 insert arrangement patterns available, accommodating from a minimum of 3 to a maximum of 55 circuits
  - Alternate positioning available
  - Various finishes are available (for information on non-cadmium zinc cobalt plating, consult factory)



## Amphenol Miniature Cylindrical MIL-DTL- 26482, Series 2 Connectors

class descriptions, performance specifications

### CLASS DESCRIPTIONS

Military MIL-DTL-26482, Series 2	Description
Class L	Aluminum shell, electroless nickel finish, fluid resistant
Class E	Inactive, superceded by Class L*
Class R	Inactive, superceded by Class L*
Class A	Aluminum shell, black non-conductive anodized finish, fluid resistant
-	Proprietary class G - Stainless steel shell, passivated, fluid resistant
Class W	Aluminum shell, olive drab cadmium plated, corrosion/fluid resistant

\* Ref. MIL-DTL-26482

### PERFORMANCE SPECIFICATIONS

#### SERVICE RATINGS\*\*

Service Rating	Recommended Operating AC Voltage at Sea Level	Test Voltage AC (RMS), 60 cps			
		Sea Level	50,000 ft.	70,000 ft.	110,000 ft.
I	600	1,500	500	375	200
II	1,000	2,300	750	500	200

\*\* Service rating is comparable to MS rating A. Miniature connectors rated Service Rating I will provide a minimum flashover voltage at sea level of 2000 volts AC (RMS). Service rating II is comparable to MS Service Rating D, and will provide a minimum flashover voltage of 2,800 volts AC (RMS) at sea level.

Please note that the electrical data given is not an establishment of electrical safety factors. This is left entirely in the designer's hands, as he can best determine which peak voltage, switching surges, transients, etc. can be expected in a particular circuit.

#### OPERATING TEMPERATURE RANGE

-55° C to 200° C

#### ENVIRONMENTAL SEAL

Wired, mated connectors with the specified accessory attached will meet the altitude immersion test specified in MIL-DTL-26482.

#### DURABILITY

Minimum of 500 mating cycles.

#### SHOCK AND VIBRATION REQUIREMENTS

When tested as follows, the connector shall sustain no physical damage, or electrical discontinuity exceeding one microsecond.

#### SHOCK

Pulse of an approximate half sine wave of 300g magnitude with duration of 3 milliseconds applied in 3 axes

#### VIBRATION

Sixteen hours of random vibration having a range of 50 to 2,000 Hz with a 41.7G peak level



DEFENSE LOGISTICS AGENCY  
LAND AND MARITIME  
P.O. BOX 3000  
COLUMBUS, OHIO 43218-3000

May 7, 2011

Amphenol Interconnect India Pvt. Ltd.  
105, R K Road Indraprastha,  
PUNE 411026, INDIA

Re: Notification of Qualification WIL-711-26482; TSC: 5915; Letter Number WQP 11-027982; Control Number 342698

This office has received your qualification report (Task Report No. 26482-342698-07) for M29482, Series F, A, for use. It is noted that it does not meet the requirements of WIL-711-34589. The next revision of QPL 25152 will reflect the following address:

<p><b>Supplier:</b> Amphenol Interconnect India Pvt. Ltd.  <b>Government Designation:</b> MS3470  <b>Manufacturer Designation:</b> IMB1-0 ( )  <b>Class:</b> A, L, W  <b>Control Style:</b> P, S  <b>Shell:</b> 8 Insert: 33, 98  <b>Shell:</b> 10 Insert: 0  <b>Shell:</b> 12 Insert: 3, 10  <b>Shell:</b> 14 Insert: 5, 12, 13, 19  <b>Shell:</b> 16 Insert: 8, 26  <b>Shell:</b> 18 Insert: 32  <b>Shell:</b> 20 Insert: 41  <b>Shell:</b> 22 Insert: 55  <b>Shell:</b> 24 Insert: 31, 61  <b>Test or Qualification Reference:</b> 26482-342698-07</p>	<p><b>Supplier:</b> Amphenol Interconnect India Pvt. Ltd.  <b>Government Designation:</b> MS3471  <b>Manufacturer Designation:</b> DCD1 ( )  <b>Class:</b> A, L, W  <b>Control Style:</b> P, S  <b>Shell:</b> 8 Insert: 33, 98  <b>Shell:</b> 10 Insert: 0  <b>Shell:</b> 12 Insert: 3, 10  <b>Shell:</b> 14 Insert: 5, 12, 13, 19  <b>Shell:</b> 16 Insert: 8, 26  <b>Shell:</b> 18 Insert: 32  <b>Shell:</b> 20 Insert: 41  <b>Shell:</b> 22 Insert: 55  <b>Shell:</b> 24 Insert: 31, 61  <b>Test or Qualification Reference:</b> 26482-342698-07</p>
---	---

<p><b>Supplier:</b> Amphenol Interconnect India Pvt. Ltd.  <b>Government Designation:</b> MS3473  <b>Manufacturer Designation:</b> IMB1-0 ( )  <b>Class:</b> A, L, W  <b>Control Style:</b> P, S  <b>Shell:</b> 8 Insert: 33, 98  <b>Shell:</b> 10 Insert: 6  <b>Shell:</b> 12 Insert: 3, 10  <b>Shell:</b> 14 Insert: 5, 12, 13, 19</p>	<p><b>Supplier:</b> Amphenol Interconnect India Pvt. Ltd.  <b>Government Designation:</b> M80422  <b>Manufacturer Designation:</b> DMB14 ( )  <b>Class:</b> A, L, W  <b>Control Style:</b> P, S  <b>Shell:</b> 8 Insert: 33, 98  <b>Shell:</b> 10 Insert: 0  <b>Shell:</b> 12 Insert: 3, 10  <b>Shell:</b> 14 Insert: 5, 12, 13, 19</p>
--	---

<p><b>Shell:</b> 16 Insert: 8, 26  <b>Shell:</b> 18 Insert: 32  <b>Shell:</b> 20 Insert: 41  <b>Shell:</b> 22 Insert: 55  <b>Shell:</b> 24 Insert: 31, 61  <b>Test or Qualification Reference:</b> 26482-342698-07</p>	<p><b>Shell:</b> 16 Insert: 8, 26  <b>Shell:</b> 18 Insert: 32  <b>Shell:</b> 20 Insert: 41  <b>Shell:</b> 22 Insert: 55  <b>Shell:</b> 24 Insert: 31, 61  <b>Test or Qualification Reference:</b> 26482-342698-07</p>
--	--

<p><b>Supplier:</b> Amphenol Interconnect India Pvt. Ltd.  <b>Government Designation:</b> MS3475  <b>Manufacturer Designation:</b> IMB1-0 ( )  <b>Class:</b> L, W  <b>Control Style:</b> P, S  <b>Shell:</b> 8 Insert: 33, 98  <b>Shell:</b> 10 Insert: 6  <b>Shell:</b> 12 Insert: 3, 10  <b>Shell:</b> 14 Insert: 5, 12, 13, 19  <b>Shell:</b> 16 Insert: 8, 26  <b>Shell:</b> 18 Insert: 32  <b>Shell:</b> 20 Insert: 41  <b>Shell:</b> 22 Insert: 55  <b>Shell:</b> 24 Insert: 31, 61  <b>Test or Qualification Reference:</b> 26482-342698-07</p>	<p><b>Supplier:</b> Amphenol Interconnect India Pvt. Ltd.  <b>Government Designation:</b> MS3476  <b>Manufacturer Designation:</b> IMB1-0 ( )  <b>Class:</b> A, L, W  <b>Control Style:</b> P, S  <b>Shell:</b> 8 Insert: 33, 98  <b>Shell:</b> 10 Insert: 6  <b>Shell:</b> 12 Insert: 3, 10  <b>Shell:</b> 14 Insert: 5, 12, 13, 19  <b>Shell:</b> 16 Insert: 8, 26  <b>Shell:</b> 18 Insert: 32  <b>Shell:</b> 20 Insert: 41  <b>Shell:</b> 22 Insert: 55  <b>Shell:</b> 24 Insert: 31, 61  <b>Test or Qualification Reference:</b> 26482-342698-07</p>
--	---

**Supplier:** Amphenol Interconnect India Pvt. Ltd.  
**Government Designation:** MS3486  
**Manufacturer Designation:** MS3186 ( )  
**Task Number:** 102, 106, 109, 113, 115, 117, 120, 131  
**Class:** A, B, W  
**Material:** A  
**Test or Qualification Reference:** 26482-342698-07

A detailed listing of Ex-Works Specifications (EWS) will be listed on the Qualified Products List (QPL) 26482. This qualification is subject to conditions stated in DCD 1120-24-04 and 525-6. Because we are field responsible for the accuracy and currency of this QPL, please let us know if your company discontinues production of these products. If you have any questions, please contact Mr. Edie Shen by email at [es@plm.dla.mil](mailto:es@plm.dla.mil).

Sincerely,  
  
 EDIE SHEN  
 Director  
 Source and Qualification Division

## Miniature Cylindrical MIL-DTL-26482, Series 2

insert arrangements, insert alternate positioning

### INSERT ARRANGEMENTS

Insert Arrangement	Service Rating	Total Contacts	Contact Size		
			12	16	20
8-33	I	3			3
8-98	I	3			3
10-6	I	6			6
12-3	II	3		3	
12-8	I	8			8
12-10	I	10			10
14-4	I	4	4		
14-5	II	5		5	
14-9	I	9	4		5
14-12	I	12		4	8
14-15	I	15		1	14
14-18	I	18			18
14-19	I	19			19
16-8	II	8		8	
16-23	I	23		1	22
16-26	I	26			26
18-8	I	8	8		
18-11	II	11		11	
18-30	I	30		1	29
18-32	I	32			32
20-16	II	16		16	
20-24	I	24			24
20-39	I	39		2	37
20-41	I	41			41
22-12	I	12	12		
22-19	I	19	19		
22-21	II	21		21	
22-32	I	32			32
22-41	I	41		14	27
22-55	I	55			55
22-95	I	32	6		26
24-19	II	19	19		
24-31	I	31		31	
24-61	I	61			61

### INSERT ALTERNATE POSITIONING

To avoid cross-plugging problems in applications requiring the use of more than one connector of the same size and arrangement, alternate rotations are available as indicated in the chart below.

As shown in the diagram, the front face of the pin insert is rotated within the shell in a clockwise direction from the normal shell key. The socket insert would be rotated counter-clockwise the same number of degrees in respect to the normal shell key.

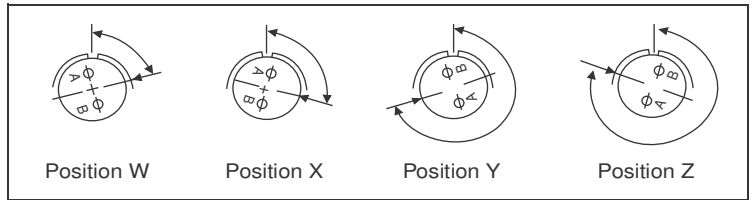

View looking into front face of pin insert or rear of socket insert.

Insert Arrangement	Degrees			
	W	X	Y	Z
8-33	90	-	-	-
8-98	-	-	-	-
10-6	90	-	-	-
12-3	-	-	180	-
12-8	90	112	203	292
12-10	60	155	270	295
14-4	45	-	-	-
14-5	40	92	184	273
14-9	15	90	180	270
14-12	43	90	-	-
14-15	17	110	155	234
14-18	15	90	180	270
14-19	30	165	315	-
16-8	54	152	180	331
16-23	158	270	-	-
16-26	60	-	275	338
18-8	180	-	-	-
18-11	62	119	241	340
18-30	18	193	285	350
18-32	85	138	222	265
20-16	238	318	333	347
20-24	70	145	215	290
20-39	63	144	252	333
20-41	45	126	225	-
22-12	-	-	-	-
22-19	15	90	225	308
22-21	16	135	175	349
22-32	72	145	215	288
22-41	39	135	264	-
22-55	30	142	226	314
22-95	26	180	266	-
24-19	30	165	315	-
24-31	90	225	255	-
24-61	90	180	270	324



## Miniature Cylindrical MIL-DTL-26482, Series 2

Contact Legend			
Symbol			
Contact size	20	16	12

### insert arrangements



front face of pin insert or rear face of socket insert illustrated

Insert Arrangement	8-33	8-98	10-06	12-03	*12-08	12-10
Service Rating	I	I	I	II	I	I
Number of Contacts	3	3	6	3	8	10
Contact Size	20	20	20	16	20	20
Insert Arrangement	*14-04	14-05	*14-09	14-12	14-15	
Service Rating	I	II	I	I	I	
Number of Contacts	4	5	5 4	8 4	14 1	
Contact Size	12	16	20 12	20 16	20 16	
Insert Arrangement	*14-18	14-19	*16-08	*16-23	16-26	
Service Rating	I	I	II	I	I	
Number of Contacts	18	19	8	22 1	26	
Contact Size	20	20	16	20 16	20	

\*Available on request. Please contact factory.



## Miniature Cylindrical MIL-DTL-26482, Series 2

Contact Legend			
Symbol			
Contact size	20	16	12

### insert arrangements

front face of pin insert or rear face of socket insert illustrated

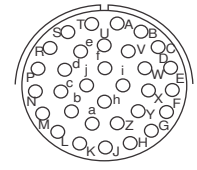
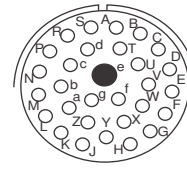
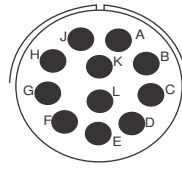
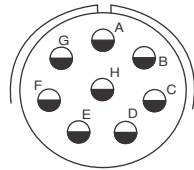

Insert Arrangement	*18-08	*18-11	18-30	18-32
Service Rating	I	II	I	I
Number of Contacts	8	11	29 1	32
Contact Size	12	16	20 16	20

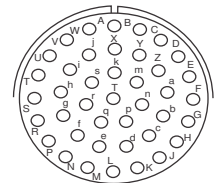
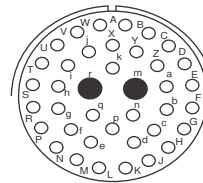
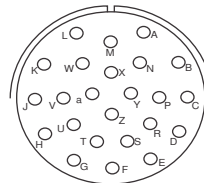
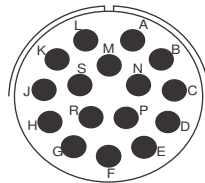

Insert Arrangement	*20-16	*20-24	*20-39	20-41
Service Rating	II	I	I	I
Number of Contacts	16	24	37 2	41
Contact Size	16	20	20 16	20

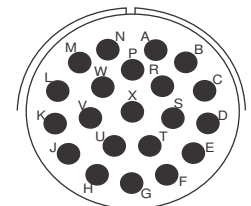
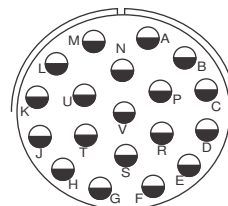
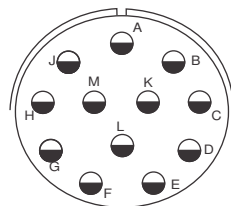



Insert Arrangement	*22-12	*22-19	*22-21
Service Rating	I	I	II
Number of Contacts	12	19	21
Contact Size	12	12	16

\*Available on request. Please contact factory.

## Miniature Cylindrical MIL-DTL-26482, Series 2

### Contact Legend

Symbol			
Contact size	20	16	12

### insert arrangements

front face of pin insert or rear face of socket insert illustrated

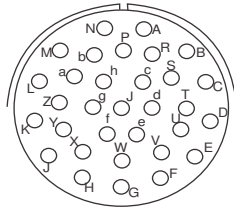

Insert Arrangement	*22-32
Service Rating	I
Number of Contacts	32
Contact Size	20

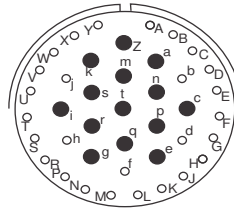

Insert Arrangement	*22-41
Service Rating	I
Number of Contacts	27 14
Contact Size	20 16

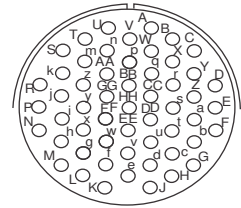

Insert Arrangement	22-55
Service Rating	I
Number of Contacts	55
Contact Size	20

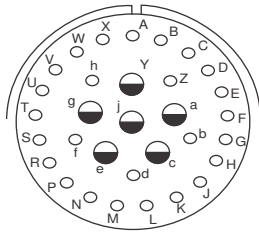

Insert Arrangement	*22-95
Service Rating	I
Number of Contacts	26 6
Contact Size	20 12

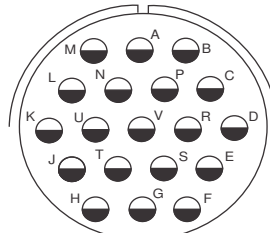

Insert Arrangement	*24-19
Service Rating	II
Number of Contacts	19
Contact Size	12

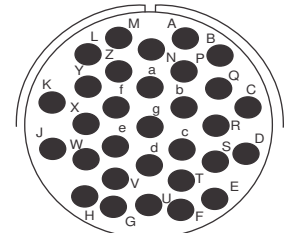

Insert Arrangement	24-31
Service Rating	I
Number of Contacts	31
Contact Size	16

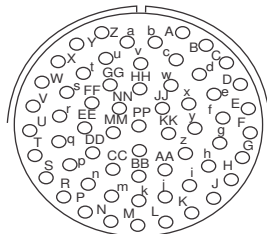

Insert Arrangement	24-61
Service Rating	I
Number of Contacts	61
Contact Size	20

\*Available on request. Please contact factory.

## Miniature Cylindrical MIL-C-26482, Series 2 IMB1- 0

Receptacle Shell, Wall Mount with Narrow Flange,  
Bayonet Coupling

**Military No. MS3470**

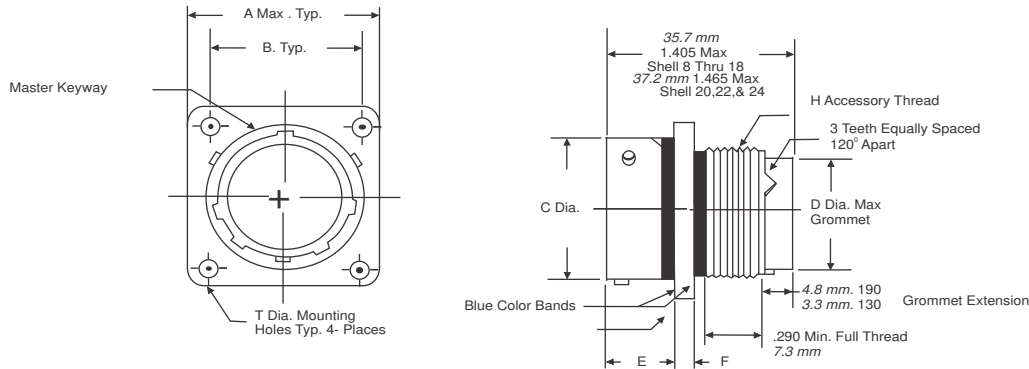

To complete order number see ordering information, page 14.  
Inches

Shell Size	A Max.	B ±.005	C Dia. ±.003	D Dia. Max.	E	F ±.016	H Accessory Thread Class 2A	T ±.005
8	.828	.594	.471	.305	.462/.431	.062	.5000-20 UNF	.120
10	.954	.719	.588	.405	.462/.431	.062	.6250-24 UNEF	.120
12	1.047	.812	.748	.531	.462/.431	.062	.7500-20 UNEF	.120
14	1.141	.906	.873	.665	.462/.431	.062	.8750-20 UNEF	.120
16	1.234	.969	.998	.790	.462/.431	.062	1.0000-20 UNEF	.120
18	1.328	1.062	1.123	.869	.462/.431	.062	1.0625-18 UNEF	.120
20	1.453	1.156	1.248	.994	.587/.556	0.94	1.1875-18 UNEF	.120
22	1.578	1.250	1.373	1.119	.587/.556	0.94	1.3125-18 UNEF	.120
24	1.703	1.375	1.498	1.244	.620/.589	0.94	1.4375-18 UNEF	.147

### Millimeters

Shell Size	A Max.	B ±.005	C Dia. ±.003	D Dia. Max.	E	F ±.016	H Accessory Thread Class 2A	T ±.005
8	21.0	15.0	12.0	07.7	11.7/10.9	1.6	.5000-20 UNF	3.0
10	24.2	18.3	15.0	10.3	11.7/10.9	1.6	.6250-24 UNEF	3.0
12	26.6	20.6	19.0	13.5	11.7/10.9	1.6	.7500-20 UNEF	3.0
14	29.0	23.0	22.1	16.9	11.7/10.9	1.6	.8750-20 UNEF	3.0
16	31.3	24.6	25.3	20.1	11.7/10.9	1.6	1.0000-20 UNEF	3.0
18	33.7	27.0	28.5	22.1	11.7/10.9	1.6	1.0625-18 UNEF	3.0
20	37.0	29.4	31.5	25.2	14.9/14.1	2.4	1.1875-18 UNEF	3.0
22	40.0	31.7	34.9	28.4	14.9/14.1	2.4	1.3125-18 UNEF	3.0
24	43.2	35.0	38.0	31.6	15.7/14.9	2.4	1.4375-18 UNEF	3.7

## Miniature Cylindrical MIL-DTL-26482, Series 2 IMB1-2

Receptacle Shell, Wall Mount with Wide Flange,  
Bayonet Coupling

**Military No. MS3472**

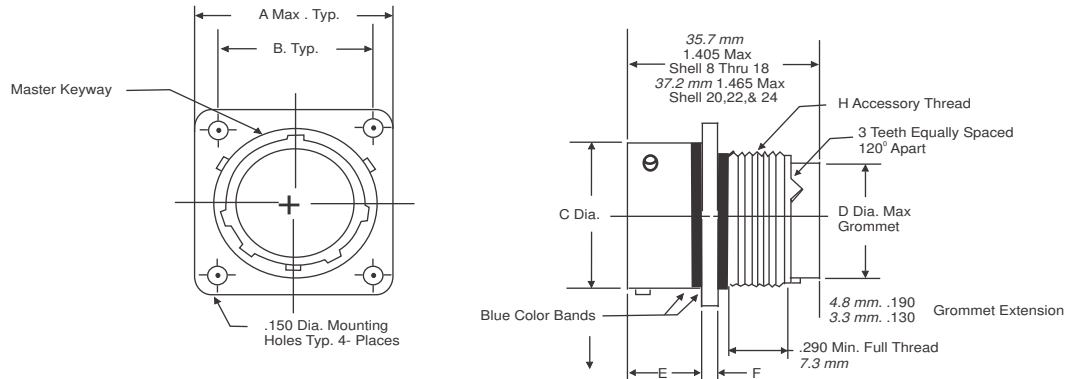

To complete order number see ordering information, page 14.

Shell Size	A Max.	B ±.005	C Dia. ±.003	D Dia. Max.	E	F ±.016	H Thread Class 2A
8	1.065	.734	.471	.305	.493/.462	.062	.5000-20 UNF
10	1.141	.812	.588	.405	.493/.462	.062	.6250-24 UNEF
12	1.266	.938	.748	.531	.493/.462	.062	.7500-20 UNEF
14	1.360	1.031	.873	.665	.493/.462	.062	.8750-20 UNEF
16	1.453	1.125	.998	.790	.493/.462	.062	1.0000-20 UNEF
18	1.532	1.203	1.123	.869	.493/.462	.062	1.0625-18 UNEF
20	1.688	1.297	1.248	.994	.587/.556	0.94	1.1875-18 UNEF
22	1.766	1.375	1.373	1.119	.587/.556	0.94	1.3125-18 UNEF
24	1.891	1.500	1.498	1.244	.620/.589	0.94	1.4375-18 UNEF

### Millimeters

Shell Size	A Max.	B ±.005	C Dia. ±.003	D Dia. Max.	E	F ±.016	H Thread Class 2A
8	27.1	18.6	11.9	7.7	11.7/10.9	1.5	.50000-20 UNF
10	29.0	20.6	14.9	10.3	11.7/10.9	1.5	.6250-24 UNEF
12	32.1	23.8	19.0	13.5	11.7/10.9	1.5	.7500-20 UNEF
14	34.5	26.1	22.1	16.9	11.7/10.9	1.5	.8750-20 UNEF
16	36.9	28.6	25.3	20.0	11.7/10.9	1.5	1.0000-20 UNEF
18	38.9	30.5	28.5	22.0	11.7/10.9	1.5	1.0625-18 UNEF
20	42.9	32.9	31.7	25.3	14.9/14.1	2.3	1.1875-18 UNEF
22	44.8	34.9	34.8	28.4	14.9/14.1	2.3	1.3125-18 UNEF
24	48.0	38.1	38.0	31.6	15.7/14.9	2.3	1.4375-18 UNEF

## Miniature Cylindrical MIL-DTL-26482, Series 2 IMB1-1

Receptacle Shell, Cable Connecting,  
Bayonet Coupling

**Military No. MS3471**

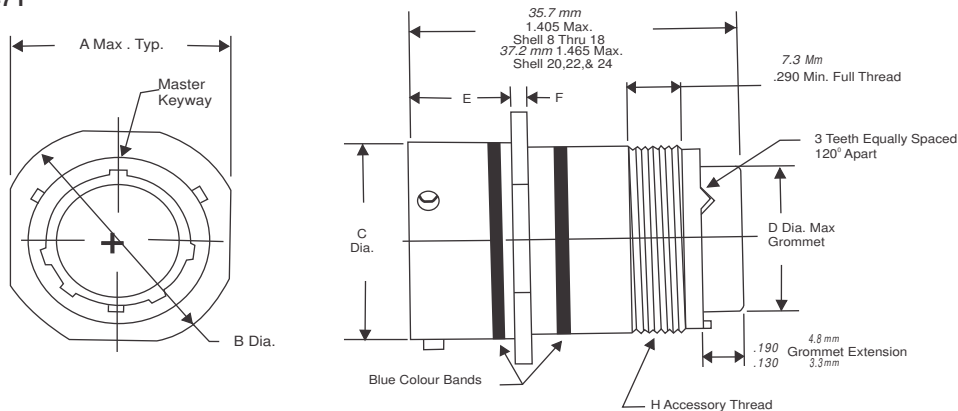

To complete order number see ordering information, page 14.

Shell Size	A Max.	B Dia. ±.020	C Dia. ±.003	D Dia. Max.	E	F ±.016	H Thread Class 2A
8	.828	.938	.471	.305	.462/.431	.062	.5000-20 UNF
10	.954	1.062	.588	.405	.462/.431	.062	.6250-24 UNEF
12	1.047	1.156	.748	.531	.462/.431	.062	.7500-20 UNEF
14	1.141	1.250	.873	.665	.462/.431	.062	.8750-20 UNEF
16	1.234	1.344	.998	.790	.462/.431	.062	1.0000-20 UNEF
18	1.328	1.438	1.123	.869	.462/.431	.062	1.0625-18 UNEF
20	1.453	1.562	1.248	.994	.587/.556	0.94	1.1875-18 UNEF
22	1.578	1.688	1.373	1.119	.587/.556	0.94	1.3125-18 UNEF
24	1.703	1.812	1.498	1.244	.620/.589	0.94	1.4375-18 UNEF

Millimeters.

Shell Size	A Max.	B Dia. ±.020	C Dia. ±.003	D Dia. Max.	E	F ±.016	H Thread Class 2A
8	21.0	23.8	12.0	7.7	11.7/10.91	1.6	.5000-20 UNF
10	24.2	27.0	14.9	10.2	11.7/10.9	1.6	.6250-24 UNEF
12	26.6	29.3	18.8	13.5	11.7/10.9	1.6	.7500-20 UNEF
14	29.0	31.7	22.1	16.9	11.7/10.9	1.6	.8750-20 UNEF
16	31.3	34.1	25.3	20.0	11.7/10.91	1.6	1.0000-20 UNEF
18	33.7	36.5	28.5	22.1	11.7/10.9	1.6	1.0625-18 UNEF
20	36.9	39.7	31.7	25.2	14.9/14.1	2.4	1.1875-18 UNEF
22	40.0	42.9	34.9	28.42	14.9/14.1	2.4	1.3125-18 UNEF
24	43.2	46.0	38.0	31.6	15.7/14.9	2.4	1.4375-18 UNEF

## Miniature Cylindrical MIL-DTL-26482, Series 2 IMB1- 4

Receptacle Shell, Jam Nut Mount,  
Bayonet Coupling

**Military No. MS3474**

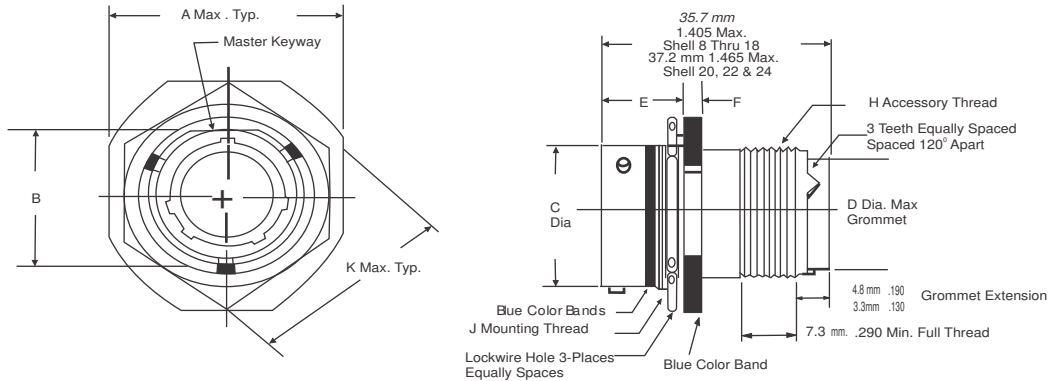

To complete order number see ordering information, page 14.

Shell Size	A Max.	B ±.005	C Dia. ±.003	D Dia. Max.	E	F	H Accessory Thread Class 2A	J Mounting Thread Class 2A	K Max.
8	.954	.525	.471	.305	.707/.658	.113/.086	.5000-20 UNF	.5625-24 UNEF	.767
10	1.078	.650	.588	.405	.707/.658	.113/.086	.6250-24 UNEF	.6875-24 UNEF	.892
12	1.266	.813	.748	.531	.707/.658	.113/.086	.7500-20 UNEF	.8750-20 UNEF	1.079
14	1.391	.937	.873	.665	.707/.658	.113/.086	.8750-20 UNEF	1.0000-20 UNEF	1.205
16	1.516	1.061	.998	.790	.707/.658	.113/.086	1.0000-20 UNEF	1.1250-18 UNEF	1.329
18	1.641	1.186	1.123	.869	.707/.658	.113/.086	1.0625-18 UNEF	1.2500-18 UNEF	1.455
20	1.828	1.311	1.248	.994	.772/.721	.148/.096	1.1875-18 UNEF	1.3750-18 UNEF	1.579
22	1.954	1.436	1.373	1.119	.772/.721	.148/.096	1.3125-18 UNEF	1.5000-18 UNEF	1.705
24	2.078	1.561	1.498	1.244	.772/.721	.148/.096	1.4375-18 UNEF	1.6250-18 UNEF	1.829

Millimeters

Shell Size	A Max.	B ±.005	C Dia. ±.003	D Dia. Max.	E	F	H Accessory Thread Class 2A	J Mounting Thread Class 2A	K Max.
8	24.2	13.3	12.0	7.7	17.9/17.7	2.8/2.1	.5000-20 UNF	.5625-24 UNEF	19.5
10	27.4	16.5	15.0	10.3	17.9/17.7	2.8/2.1	.6250-24 UNEF	.6875-24 UNEF	22.6
12	32.1	20.6	19.0	13.4	17.9/17.7	2.8/2.1	.7500-20 UNEF	.8750-20 UNEF	27.4
14	35.3	23.8	22.2	16.9	17.9/17.7	2.8/2.1	.8750-20 UNEF	1.0000-20 UNEF	30.6
16	38.5	27.0	25.3	20.0	17.9/17.7	2.8/2.1	1.0000-20 UNEF	1.1250-18 UNEF	33.7
18	41.7	30.1	28.5	22.1	17.9/17.7	2.8/2.1	1.0625-18 UNEF	1.2500-18 UNEF	37.0
20	46.4	33.3	31.7	25.2	19.6/18.3	3.7/2.4	1.1875-18 UNEF	1.3750-18 UNEF	40.1
22	49.6	36.5	34.9	28.4	19.6/18.3	3.7/2.4	1.3125-18 UNEF	1.5000-18 UNEF	43.3
24	52.7	39.6	38.0	31.6	19.6/18.3	3.7/2.4	1.4375-18 UNEF	1.6250-18 UNEF	46.4



**Miniature Cylindrical MIL-DTL-26482, Series 2**  
**IMB1-6** straight plug

**IMB1-5** straight plug with RFI grounding fingers

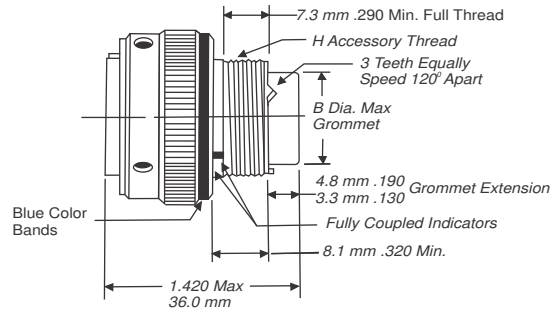
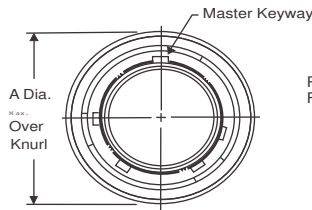
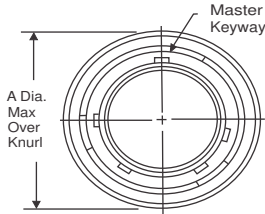

Plug Shell,  
Bayonet Coupling

**Military No. MS3476**

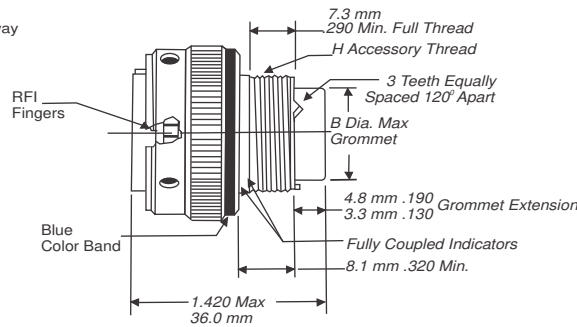

Plug Shell, RFI Grounding,  
Bayonet Coupling

**Military No. MS3475**

To complete order number see ordering information, page 14.

Shell Size	A Dia. Max.	B Dia. Max.	H Accessory Thread Class 2A
8	.782	.305	.5000-20 UNF
10	.926	.405	.6250-24 UNEF
12	1.043	.531	.7500-20 UNEF
14	1.183	.665	.8750-20 UNEF
16	1.305	.790	1.0000-20 UNEF
18	1.391	.869	1.0625-18 UNEF
20	1.531	.994	1.1875-18 UNEF
22	1.656	1.119	1.3125-18 UNEF
24	1.777	1.244	1.4375-18 UNEF

Millimeters

Shell Size	A Dia. Max.	B Dia. Max.	H Accessory Thread Class 2A
8	19.8	3.1	.5000-20 UNF
10	23.5	10.2	.6250-24 UNEF
12	26.5	13.5	.7500-20 UNEF
14	30.0	16.9	.8750-20 UNEF
16	33.1	20.0	1.0000-20 UNEF
18	35.3	22.0	1.0625-18 UNEF
20	38.9	25.2	1.1875-18 UNEF
22	42.0	28.4	1.3125-18 UNEF
24	45.1	31.6	1.4375-18 UNEF



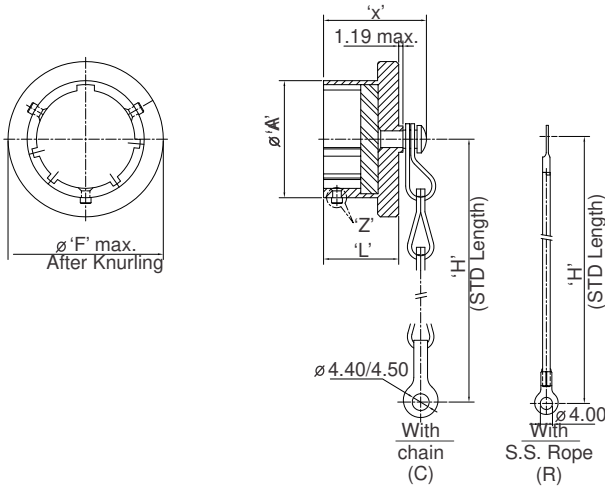

### Ordering Information (MIL Part Number)

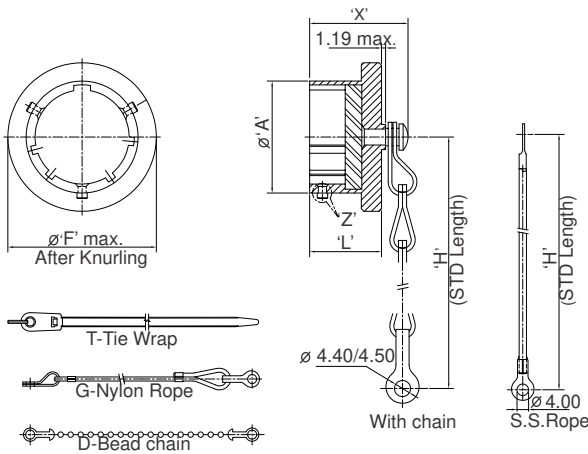
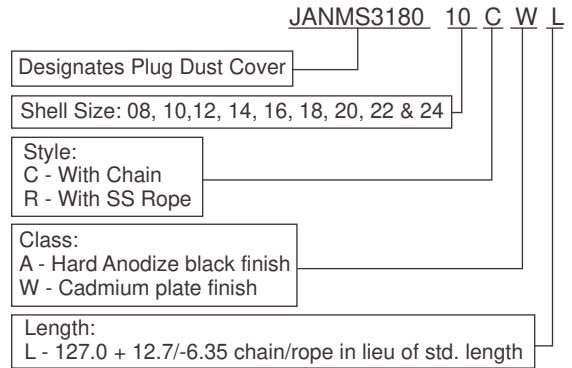

### Ordering Information (Proprietary Part Number)

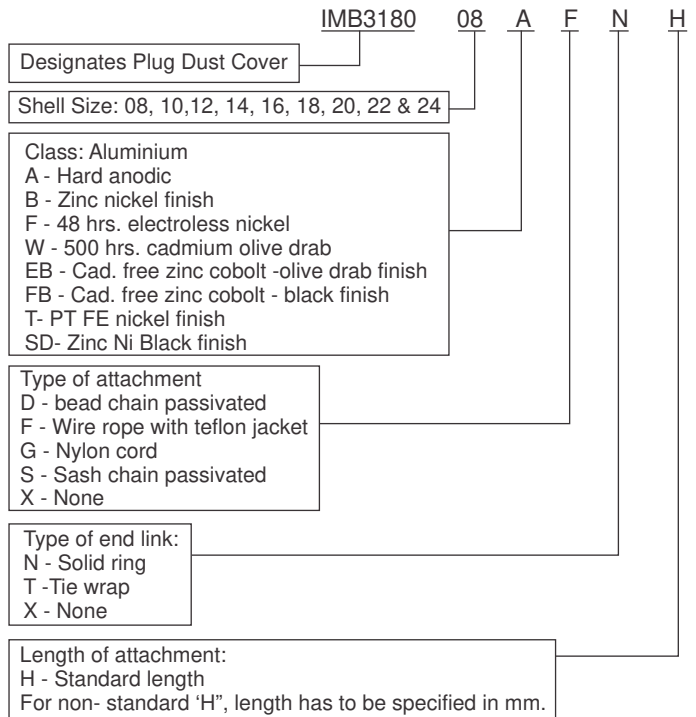

All Dimensions are in mm

Shell Size	ø A Ref.	ø F Max. Overall.	H +12.70/-6.35	L Max. Length	X Max. Overall	ø F For Heavy Duty
08	12.01	18.26	76.20	14.27	19.84	22.10
10	14.99	21.44				24.86
12	19.05	25.40				29.24
14	22.22	28.58				32.41
16	25.40	31.75	101.60	15.88	21.44	35.58
18	28.58	34.92				38.22
20	31.75	38.10				41.94
22	34.92	41.28				45.11
24	38.10	44.45				48.18

All Dimensions for reference only

### Cap without attachment

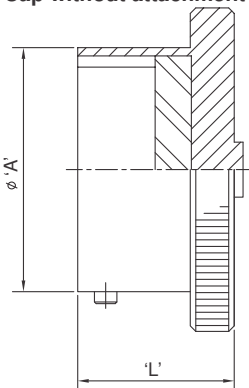

### Ordering information IMB3180 - 08 - A - V1

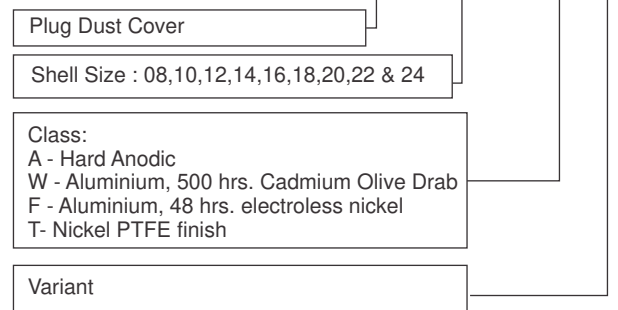

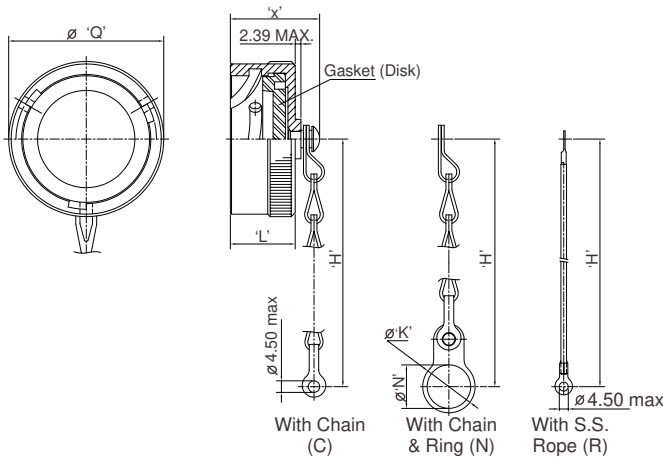

### Ordering Information (MIL Part Number)

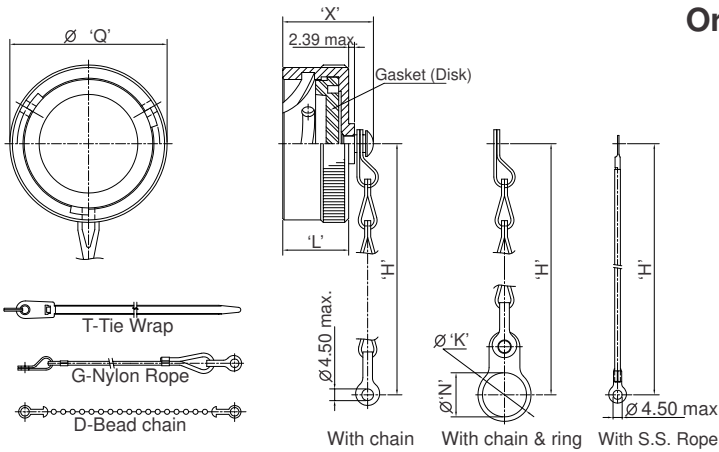
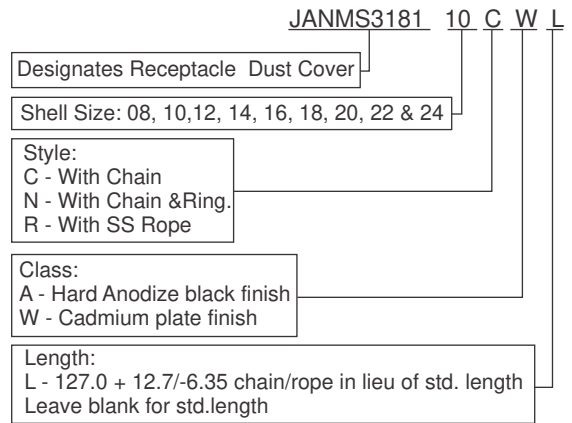

### Ordering Information (Proprietary Part Number)

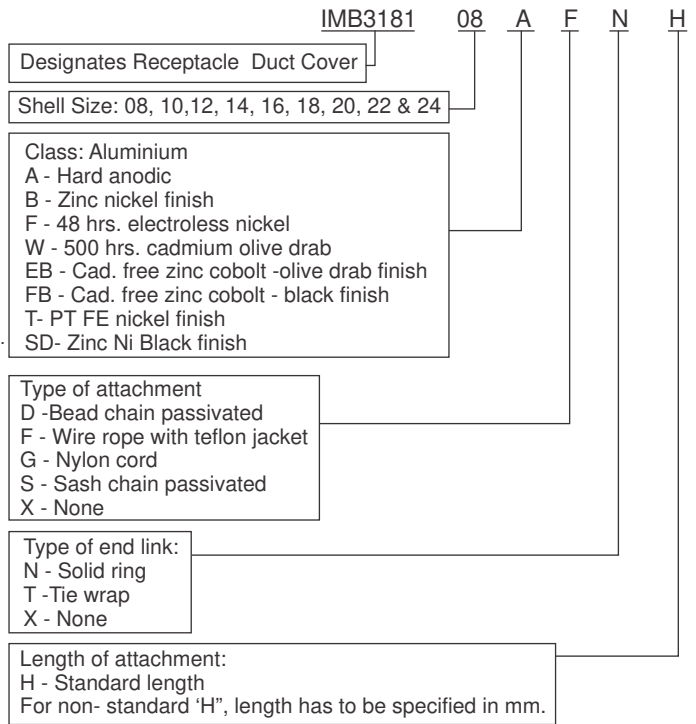

All Dimensions are in mm

Shell Size	H +12.70/ -6.35	$\phi K$ MAX.	L Max.	$\phi N$ MIN	$\phi Q$ MIN	X Max.
08	20.62	20.62	14.27	14.68	18.64	21.44
10	76.20	25.40		17.86	21.82	
12	30.18	22.63		25.40		
14	88.90	36.67		25.81	28.58	
16	39.67	28.98		31.75		
18	42.88	32.16		34.92		
20	46.02	35.33		38.10		
22	101.60	49.23		38.51	41.28	
24	52.37	15.29	41.68	44.45	22.22	

All Dimensions for reference only

### Cap without attachment

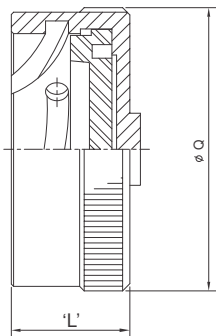

### Ordering information IMB3181 - 08 - A - V1

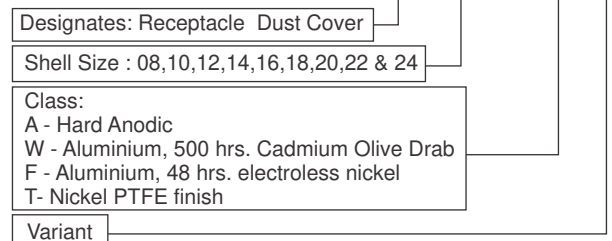

### GASKET TO BE CEMENTED TO DUST CAP

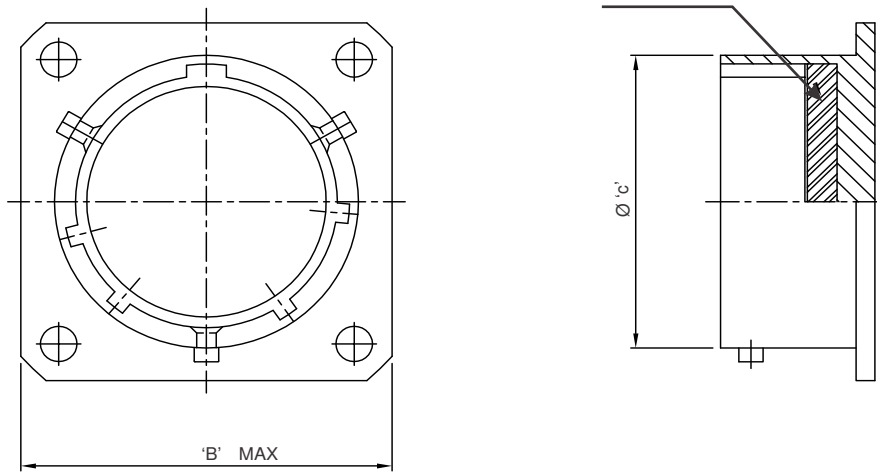

SIZE	'B' SQ	'C' ±0.08
08	20.62	11.96
10	23.80	14.94
12	26.39	18.97
14	28.58	22.17
16	31.34	25.32
18	33.32	28.52
20	36.50	31.70
22	39.67	34.87
24	42.85	38.05

IMB3115-10-W

Product Designation

Shell Size

FINISH:  
 A: Hard Anodized  
 N- Electroless Nickel  
 W- Cadmium Olive Drab  
 SD- Zinc Nickel Black Finish  
 \* For other finish contact factory

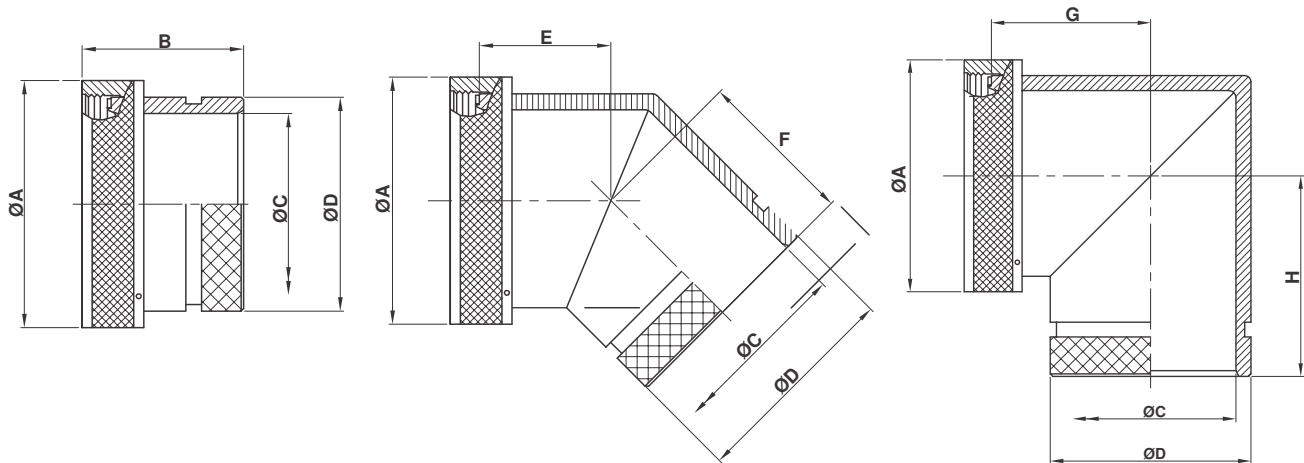

## Part Numbering System

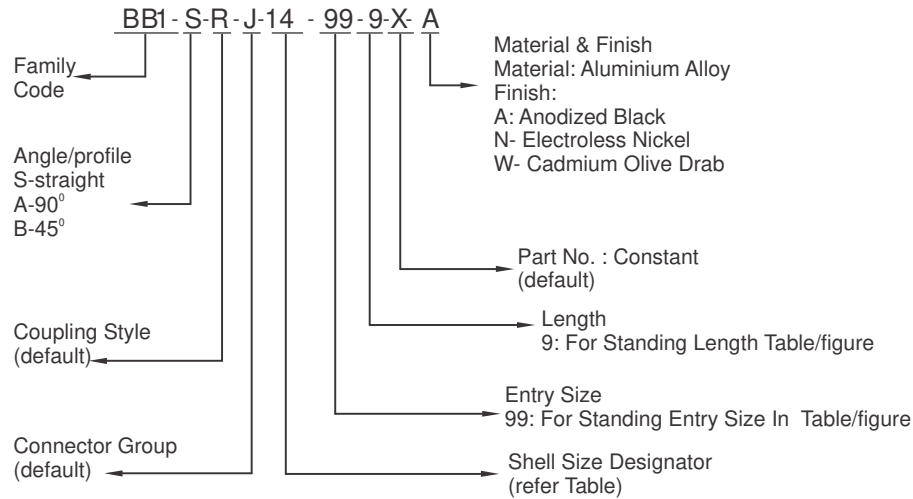

## Dimensions

SHELL SIZE DESIGNATOR	ØA MAX.		B MAX.		ØC MIN.		ØD MIN.		E MAX.		F MAX.		G MAX.		H MAX.	
	INCH	MM	INCH	MM	INCH	MM	INCH	MM	INCH	MM	INCH	MM	INCH	MM	INCH	MM
08	0.62	15.67	1.19	30.15	0.25	6.35	0.53	13.54	0.64	16.23	0.81	20.57	0.75	19.05	0.92	23.37
10	0.73	18.64	1.19	30.15	0.36	9.02	0.61	15.37	0.66	16.87	0.84	21.34	0.81	20.57	0.98	24.89
12	0.86	21.79	1.19	30.15	0.49	12.47	0.77	19.66	0.69	17.48	0.86	21.84	0.87	22.10	1.04	26.42
14	0.98	24.99	1.19	30.15	0.57	14.35	0.84	21.29	0.71	17.91	0.89	22.61	0.92	23.37	1.11	28.19
16	1.11	28.24	1.19	30.15	0.69	17.53	0.96	24.46	0.73	18.59	0.91	23.11	0.98	24.89	1.17	29.72
18	1.22	30.94	1.19	30.15	0.77	19.53	1.04	26.47	0.75	19.00	0.92	23.37	1.02	25.91	1.19	30.23
20	1.35	34.16	1.19	30.15	0.89	22.71	1.22	30.91	0.77	19.63	0.94	23.88	1.08	27.43	1.25	31.75
22	1.47	37.29	1.19	30.15	1.02	25.88	1.36	34.42	0.80	20.32	0.98	24.89	1.14	28.96	1.33	33.78
24	1.59	40.46	1.19	30.15	1.13	28.80	1.44	36.65	0.82	20.90	1.01	25.65	1.20	30.48	1.40	35.56

Note: \* For ordering with Military part number contact factory.

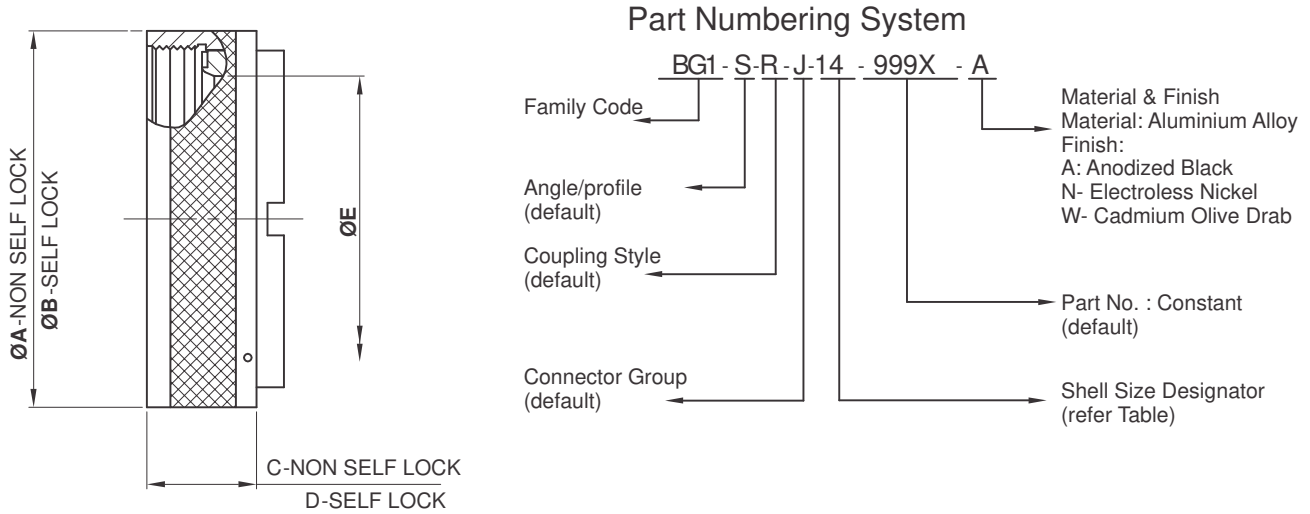

## Dimensions

SHELL SIZE DESIGNATOR	ØA MAX.		ØB MAX.		C MAX.		D MAX.		E MAX.	
	INCH	MM	INCH	MM	INCH	MM	INCH	MM	INCH	MM
08	0.62	15.67	0.89	22.48	0.54	13.72	0.71	18.03	0.27	6.86
10	0.73	18.64	1.01	25.65	0.54	13.72	0.71	18.03	0.38	9.53
12	0.86	21.79	1.14	28.83	0.54	13.72	0.71	18.03	0.51	12.98
14	0.98	24.99	1.26	32.00	0.54	13.72	0.71	18.03	0.59	14.86
16	1.11	28.24	1.39	35.18	0.54	13.72	0.71	18.03	0.71	18.03
18	1.22	30.94	1.51	38.35	0.54	13.72	0.71	18.03	0.79	20.04
20	1.35	34.16	1.64	41.53	0.54	13.72	0.71	18.03	0.91	23.22
22	1.47	37.29	1.76	44.70	0.54	13.72	0.71	18.03	1.04	26.39
24	1.59	40.46	1.89	47.88	0.54	13.72	0.71	18.03	1.15	29.31

Note: \* For ordering with Military part number contact factory.

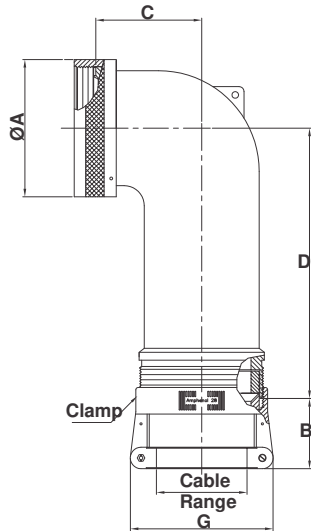

Note: When maximum cable entry is exceeded style 2 will be supplied

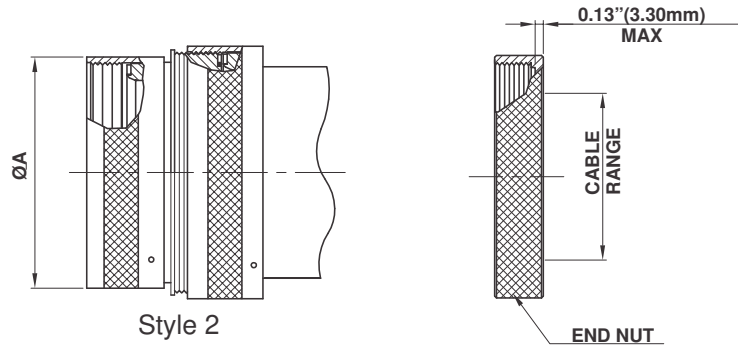

Part Numbering System

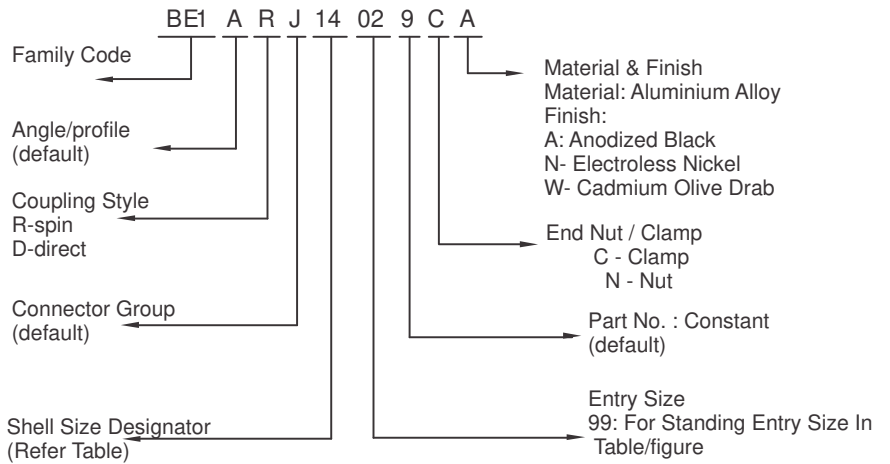

Dimensions (\*) - Denotes Style 2

SHELL SIZE DESIGNATOR	ENTRY SIZE	ØA MAX.		B REF.		C MAX.		D MAX.		G MAX.		CABLE RANGE			
		INCH	MM	INCH	MM	INCH	MM	INCH	MM	INCH	MM	MIN.		MAX.	
												INCH	MM	INCH	MM
08	01	0.62	15.67	1.03	26.09	0.67	17.02	1.26	32.00	0.96	24.31	0.13	3.18	0.25	6.35
	01	0.73	18.64	1.03	26.09	0.76	19.30	1.98	50.29	0.96	24.31	0.13	3.18	0.31	7.92
	02*	0.73	18.64	1.03	26.09	1.52	38.61	2.00	50.80	1.15	29.08	0.25	6.35	0.44	11.10
10	03	0.73	18.64	1.03	26.09	0.76	19.30	1.38	35.05	1.15	29.08	0.25	6.35	0.38	9.53
	01	0.86	21.79	1.03	26.09	0.77	19.56	2.00	50.80	0.96	24.31	0.13	3.18	0.31	7.92
	02*	0.86	21.79	1.03	26.09	1.81	45.97	2.16	54.86	1.33	33.83	0.35	8.89	0.63	15.88
12	03	0.86	21.79	1.03	26.09	0.77	19.56	2.00	50.80	1.15	29.08	0.25	6.35	0.44	11.10
	04	0.86	21.79	1.03	26.09	0.77	19.56	1.40	35.56	1.33	33.83	0.35	8.89	0.50	12.70
	01	0.98	24.99	1.03	26.09	0.87	22.10	2.07	52.58	1.15	29.08	0.25	6.35	0.44	11.10
14	02	0.98	24.99	1.03	26.09	0.87	22.10	1.72	43.69	1.33	33.83	0.35	8.89	0.58	14.61
	03*	0.98	24.99	1.06	26.90	1.89	48.01	2.33	59.18	1.55	39.40	0.50	12.70	0.75	19.05
	04	0.98	24.99	1.03	26.09	0.87	22.10	2.07	52.58	0.96	24.31	0.13	3.18	0.31	7.92
16	01	1.11	28.24	1.03	26.09	1.05	26.67	2.16	54.86	1.15	29.08	0.25	6.35	0.44	11.10
	02	1.11	28.24	1.06	26.90	1.05	26.67	1.81	45.97	1.55	39.40	0.50	12.70	0.70	17.78
	03	1.11	28.24	1.03	26.09	1.05	26.67	2.16	54.86	1.33	33.83	0.35	8.89	0.63	15.88
18	04*	1.11	28.24	1.16	29.36	2.04	51.82	2.44	61.98	1.77	44.96	0.63	15.88	0.94	23.80
	05	1.11	28.24	1.03	26.09	1.05	26.67	2.16	54.86	0.96	24.31	0.13	3.18	0.31	7.92
	01	1.22	30.94	1.03	26.09	1.14	28.96	2.33	59.18	1.33	33.83	0.35	8.89	0.63	15.88
20	02	1.22	30.94	1.16	29.36	1.14	28.96	1.98	50.29	1.77	44.96	0.63	15.88	0.78	19.79
	03	1.22	30.94	1.03	26.09	1.14	28.96	2.33	59.18	0.96	24.31	0.13	3.18	0.31	7.92
	04	1.22	30.94	1.03	26.09	1.14	28.96	2.33	59.18	1.15	29.08	0.25	6.35	0.44	11.10
22	05	1.22	30.94	1.06	26.90	1.14	28.96	2.33	59.18	1.55	39.40	0.50	12.70	0.75	19.05
	06*	1.22	30.94	1.16	29.36	2.05	52.07	2.44	61.98	1.77	44.96	0.63	15.88	0.94	23.80
	01	1.35	34.16	1.03	26.09	1.14	28.96	2.33	59.18	1.33	33.83	0.35	8.89	0.63	15.88
24	02	1.35	34.16	1.16	29.36	1.14	28.96	1.98	50.29	1.77	44.96	0.63	15.88	0.90	22.96
	03	1.35	34.16	1.03	26.09	1.14	28.96	2.33	59.18	1.15	29.08	0.25	6.35	0.44	11.10
	04	1.35	34.16	1.06	26.90	1.14	28.96	2.33	59.18	1.55	39.40	0.50	12.70	0.75	19.05
26	05	1.35	34.16	1.38	34.93	2.14	54.36	2.61	66.29	2.11	53.67	0.88	22.23	1.25	31.75
	01	1.47	37.29	1.06	26.90	1.29	32.77	2.44	61.98	1.55	39.40	0.50	12.70	0.75	19.05
	02	1.47	37.29	1.38	34.93	1.29	32.77	2.09	53.09	2.11	53.67	0.88	22.23	1.03	26.14
28	03	1.47	37.29	1.03	26.09	1.29	32.77	2.44	61.98	0.96	24.31	0.13	3.18	0.31	7.92
	04	1.47	37.29	1.03	26.09	1.29	32.77	2.44	61.98	1.15	29.08	0.25	6.35	0.44	11.10
	05	1.47	37.29	1.03	26.09	1.29	32.77	2.44	61.98	1.33	33.83	0.35	8.89	0.63	15.88
30	06	1.47	37.29	1.16	29.36	1.29	32.77	2.44	61.98	1.77	44.96	0.63	15.88	0.94	23.80
	07*	1.47	37.29	1.38	34.93	2.14	54.36	2.61	66.29	2.11	53.67	0.88	22.23	1.25	31.75
	01	1.59	40.46	1.06	26.90	1.29	32.77	2.44	61.98	1.55	39.40	0.50	12.70	0.75	19.05
32	02	1.59	40.46	1.38	34.93	1.29	32.77	2.09	53.09	2.11	53.67	0.88	22.23	1.14	29.06
	03	1.59	40.46	1.03	26.09	1.29	32.77	2.44	61.98	1.33	33.83	0.35	8.89	0.63	15.88
	04	1.59	40.46	1.16	29.36	1.29	32.77	2.44	61.98	1.77	44.96	0.63	15.88	0.94	23.80
34	05*	1.59	40.46	1.38	34.93	2.15	54.61	2.61	66.29	2.12	53.75	0.88	22.23	1.25	31.75

Note: \* For ordering with Military part number contact factory.

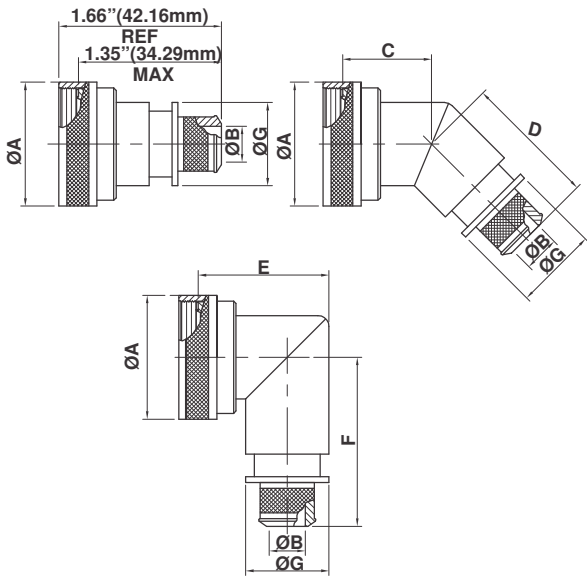

## Part Numbering System

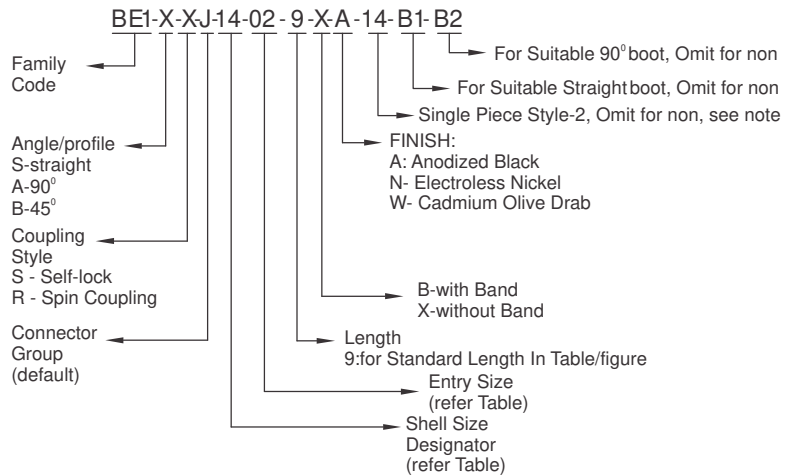

## Dimensions

SHELL SIZE DESIGNATOR	ENTRY SIZE	ØA MAX.		ØB		C MAX.		D MAX.		E MAX.		F MAX.		G MAX.	
		INCH	MM	<sup>+0.00</sup> <sub>-0.02</sub> INCH	<sup>+0.00</sup> <sub>-0.50</sub> MM	INCH	MM	INCH	MM	INCH	MM	INCH	MM	INCH	MM
08	01	0.89	22.48	N/A	N/A	0.87	22.10	1.16	29.46	1.19	30.18	1.42	35.99	N/A	N/A
	02			0.26	6.60									0.56	14.22
10	01	1.01	25.65	N/A	N/A	0.89	22.61	1.18	29.97	1.28	32.54	1.48	37.59	N/A	N/A
	02			0.32	8.13									0.63	16.00
12	01	1.14	28.83	0.32	8.13	0.92	23.37	1.20	30.48	1.41	35.71	1.54	39.17	0.63	16.00
	02			0.45	11.43									0.75	19.05
14	01	1.26	32.00	0.45	11.43	0.94	23.88	1.22	30.99	1.53	38.89	1.61	40.77	0.63	19.05
	02			0.57	14.48									0.89	22.61
16	01	1.39	35.18	0.51	12.95	0.96	24.38	1.25	31.75	1.66	42.06	1.67	42.34	0.82	20.83
	02			0.64	16.26									0.95	24.13
18	01	1.51	38.35	0.64	16.26	0.98	24.89	1.26	32.00	1.72	43.64	1.73	43.94	0.95	24.13
	02			0.76	19.30									1.07	27.18
20	01	1.64	41.53	0.64	16.26	1.00	25.40	1.29	32.77	1.84	46.84	1.79	45.52	0.95	24.13
	02			0.82	20.83									1.13	28.07
22	01	1.76	44.70	0.70	17.78	1.03	26.16	1.31	33.27	1.94	49.23	1.85	46.99	1.02	25.99
	02			0.95	24.13									1.26	32.00
24	01	1.89	47.88	0.76	19.30	1.05	26.67	1.34	34.04	2.09	53.16	1.92	48.69	1.07	27.18
	02			1.01	25.65									1.32	33.53

Note: \* For ordering with Military part number contact factory.



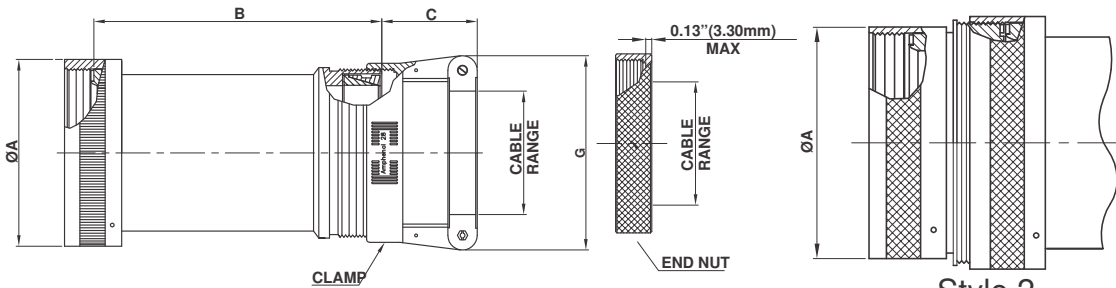

Style 2

Note: When maximum cable entry is exceeded Style 2 will be supplied

Part Numbering System

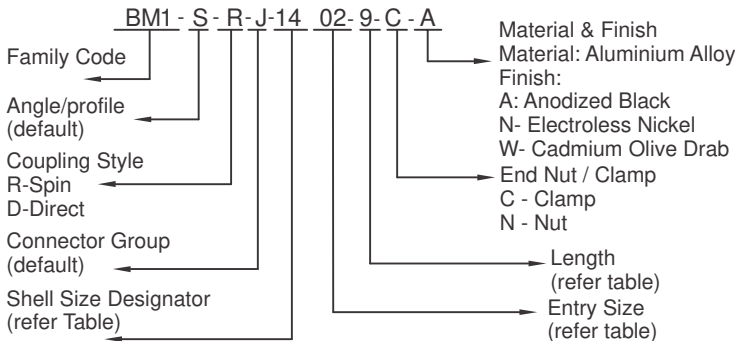

Dimensions \* - Indicates Style 2 in table

SHELL SIZE DESIGNATOR	ENTRY SIZE	LENGTH	ØA MAX.		B MAX.		C REF.		G MAX.		CABLE RANGE			
			INCH	MM	INCH	MM	INCH	MM	INCH	MM	MIN.		MAX.	
											INCH	MM	INCH	MM
8	01	1	0.62	15.67	2.13	54.10	1.03	26.09	0.96	24.31	0.13	3.18	0.25	6.35
		2	0.62	15.67	3.13	79.50	1.03	26.09	0.96	24.31	0.13	3.18	0.25	6.35
	02	1	0.62	15.67	2.88	73.15	1.03	26.09	1.15	29.08	0.25	6.35	0.44	11.10
		2	0.62	15.67	3.88	98.55	1.03	26.09	1.15	29.08	0.25	6.35	0.44	11.10
10	01	1	0.73	18.64	2.13	54.10	1.03	26.09	0.96	24.31	0.13	3.18	0.31	7.92
		2	0.73	18.64	3.13	79.50	1.03	26.09	0.96	24.31	0.13	3.18	0.31	7.92
	02	1	0.73	18.64	2.88	73.15	1.03	26.09	1.15	29.08	0.25	6.35	0.44	11.10
		2	0.73	18.64	3.88	98.55	1.03	26.09	1.15	29.08	0.25	6.35	0.44	11.10
12	01	1	0.86	21.79	2.13	54.10	1.03	26.09	1.15	29.08	0.25	6.35	0.38	9.53
		2	0.86	21.79	3.13	79.50	1.03	26.09	1.15	29.08	0.25	6.35	0.38	9.53
	02	1	0.86	21.79	2.88	73.15	1.03	26.09	1.33	33.83	0.35	8.89	0.63	15.88
		2	0.86	21.79	3.88	98.55	1.03	26.09	1.33	33.83	0.35	8.89	0.63	15.88
14	01	1	0.98	24.99	2.13	54.10	1.03	26.09	1.33	33.83	0.35	8.89	0.58	14.61
		2	0.98	24.99	3.13	79.50	1.03	26.09	1.33	33.83	0.35	8.89	0.58	14.61
	02	1	0.98	24.99	2.88	73.15	1.06	26.90	1.55	39.40	0.50	12.70	0.75	19.05
		2	0.98	24.99	3.88	98.55	1.06	26.90	1.55	39.40	0.50	12.70	0.75	19.05
16	01	1	1.11	28.24	2.13	54.10	1.03	26.09	1.55	39.40	0.50	12.70	0.70	17.78
		2	1.11	28.24	3.13	79.50	1.03	26.09	1.55	39.40	0.50	12.70	0.70	17.78
	02	1	1.11	28.24	2.88	73.15	1.16	29.36	1.77	44.96	0.63	15.88	0.94	23.80
		2	1.11	28.24	3.88	98.55	1.16	29.36	1.77	44.96	0.63	15.88	0.94	23.80
20	01	1	1.35	34.16	3.13	79.50	1.03	26.09	1.33	33.83	0.35	8.89	0.63	15.88
		2	1.35	34.16	4.13	104.90	1.03	26.09	1.33	33.83	0.35	8.89	0.63	15.88
	02	1	1.35	34.16	3.13	79.50	1.06	26.90	1.55	39.40	0.50	12.70	0.75	19.05
		2	1.35	34.16	4.13	104.90	1.06	26.90	1.55	39.40	0.50	12.70	0.75	19.05
22	01	1	1.47	37.29	3.13	79.50	1.03	26.09	1.33	33.83	0.35	8.89	0.63	15.88
		2	1.47	37.29	4.13	104.90	1.03	26.09	1.33	33.83	0.35	8.89	0.63	15.88
	02	1	1.47	37.29	3.13	79.50	1.06	26.90	1.55	39.40	0.50	12.70	0.75	19.05
		2	1.47	37.29	4.13	104.90	1.06	26.90	1.55	39.40	0.50	12.70	0.75	19.05
24	01	1	1.59	40.46	4.13	104.90	1.06	26.90	1.55	39.40	0.50	12.70	0.75	19.05
		2	1.59	40.46	4.13	104.90	1.06	26.90	1.55	39.40	0.50	12.70	0.75	19.05
	02	1	1.59	40.46	3.13	79.50	1.16	29.36	1.77	44.96	0.63	15.88	0.81	20.62
		2	1.59	40.46	4.13	104.90	1.16	29.36	1.77	44.96	0.63	15.88	0.81	20.62
	03	1	1.59	40.46	4.13	104.90	1.16	29.36	1.77	44.96	0.63	15.88	0.94	23.80
		2	1.59	40.46	4.13	104.90	1.16	29.36	1.77	44.96	0.63	15.88	0.94	23.80
	04	1	1.59	40.46	3.88	98.55	1.38	34.93	2.11	53.67	0.88	22.23	1.25	31.75
		2	1.59	40.46	4.88	123.95	1.38	34.93	2.11	53.67	0.88	22.23	1.25	31.75
	05	1	1.59	40.46	3.13	79.50	1.03	26.09	1.33	33.83	0.35	8.89	0.63	15.88
		2	1.59	40.46	4.13	104.90	1.03	26.09	1.33	33.83	0.35	8.89	0.63	15.88
	06	1	1.59	40.46	3.13	79.50	1.38	34.93	2.11	53.67	0.88	22.23	1.14	29.06
		2	1.59	40.46	4.13	104.90	1.38	34.93	2.11	53.67	0.88	22.23	1.14	29.06

SHELL SIZE DESIGNATOR	ENTRY SIZE	LENGTH	ØA MAX.		B MAX.		C REF.		G MAX.		CABLE RANGE			
			INCH	MM	INCH	MM	INCH	MM	INCH	MM	MIN.		MAX.	
											INCH	MM	INCH	MM
24	01	1	1.59	40.46	3.13	79.50	1.06	26.90	1.55	39.40	0.50	12.70	0.75	19.05
		2	1.59	40.46	4.13	104.90	1.06	26.90	1.55	39.40	0.50	12.70	0.75	19.05
	02	1	1.59	40.46	3.13	79.50	1.16	29.36	1.77	44.96	0.63	15.88	0.81	20.62
		2	1.59	40.46	4.13	104.90	1.16	29.36	1.77	44.96	0.63	15.88	0.81	20.62
	03	1	1.59	40.46	4.13	104.90	1.16	29.36	1.77	44.96	0.63	15.88	0.94	23.80
		2	1.59	40.46	4.13	104.90	1.16	29.36	1.77	44.96	0.63	15.88	0.94	23.80
	04	1	1.59	40.46	3.88	98.55	1.38	34.93	2.11	53.67	0.88	22.23	1.25	31.75
		2	1.59	40.46	4.88	123.95	1.38	34.93	2.11	53.67	0.88	22.23	1.25	31.75
	05	1	1.59	40.46	3.13	79.50	1.03	26.09	1.33	33.83	0.35	8.89	0.63	15.88
		2	1.59	40.46	4.13	104.90	1.03	26.09	1.33	33.83	0.35	8.89	0.63	15.88
	06	1	1.59	40.46	3.13	79.50	1.38	34.93	2.11	53.67	0.88	22.23	1.14	29.06
		2	1.59	40.46	4.13	104.90	1.38	34.93	2.11	53.67	0.88	22.23	1.14	29.06

Note: \* For ordering with Military part number contact factory.

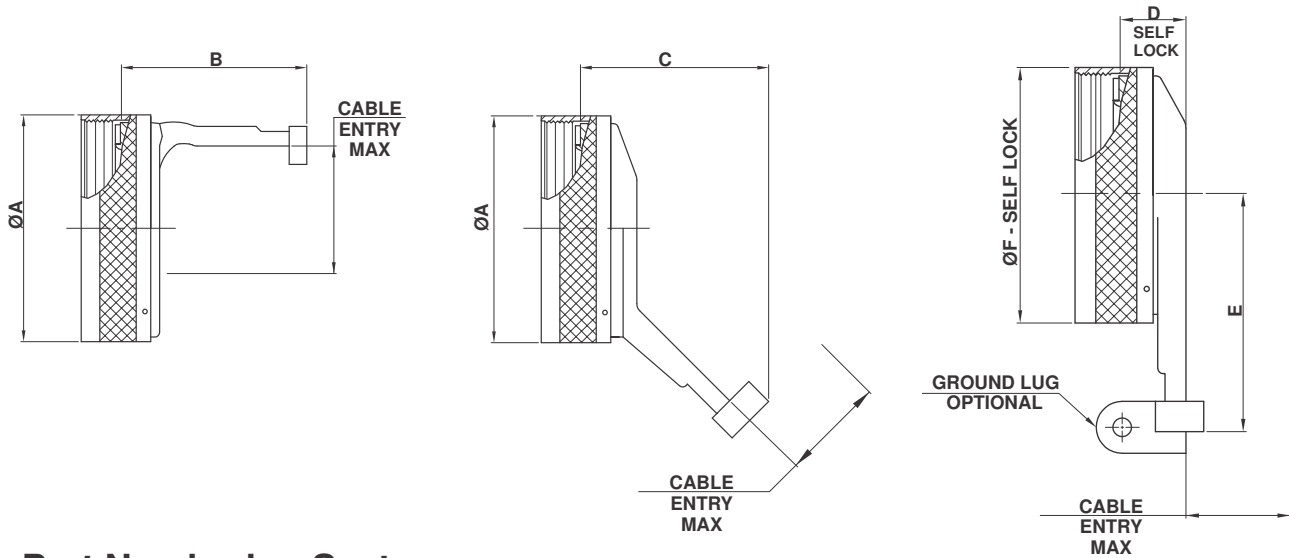

### Part Numbering System

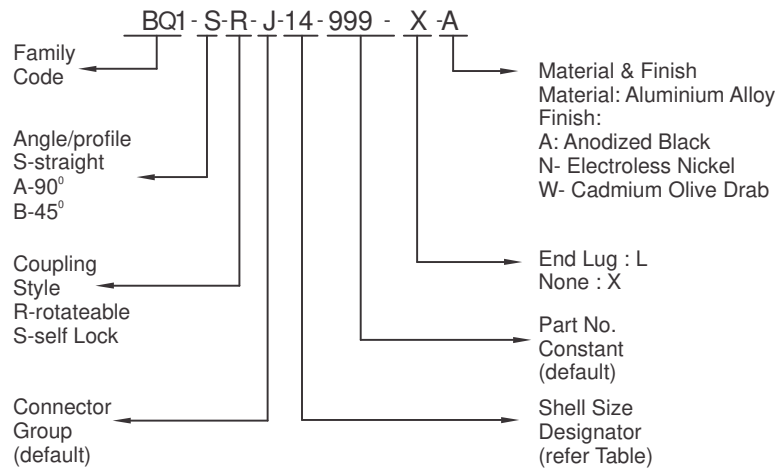

### Dimensions

SHELL SIZE DESIGNATOR	ØA MAX.		B MAX.		C MAX.		D MAX.		E MAX.		ØF MAX.		WIRING ENTRY MAX.	
	INCH	MM	INCH	MM	INCH	MM	INCH	MM	INCH	MM	INCH	MM	INCH	MM
08	0.66	16.69	0.95	24.23	1.23	31.29	0.73	18.54	1.22	30.99	0.89	22.48	0.26	6.60
10	0.78	19.86	0.95	24.23	1.23	31.29	0.73	18.54	1.29	32.77	1.01	25.65	0.37	9.27
12	0.94	23.80	0.95	24.23	1.23	31.29	0.73	18.54	1.62	41.15	1.14	28.83	0.50	12.73
14	1.05	26.67	1.20	30.58	1.23	31.29	0.73	18.54	1.66	42.16	1.26	32.00	0.58	14.61
16	1.24	31.47	1.20	30.58	1.23	31.29	0.73	18.54	1.72	43.69	1.39	35.18	0.70	17.78
18	1.38	35.00	1.20	30.58	1.23	31.29	0.73	18.54	1.72	43.69	1.51	38.35	0.78	19.79
20	1.50	38.10	1.31	33.27	1.48	37.64	0.75	19.05	1.79	45.47	1.64	41.53	0.90	22.96
22	1.63	41.43	1.43	36.32	1.48	37.64	0.75	19.05	1.85	46.99	1.76	44.70	1.03	26.14
24	1.75	44.45	1.56	39.62	1.48	37.64	0.75	19.05	1.91	48.51	1.89	47.88	1.14	29.06

Note: \* For ordering with Military part number contact factory.

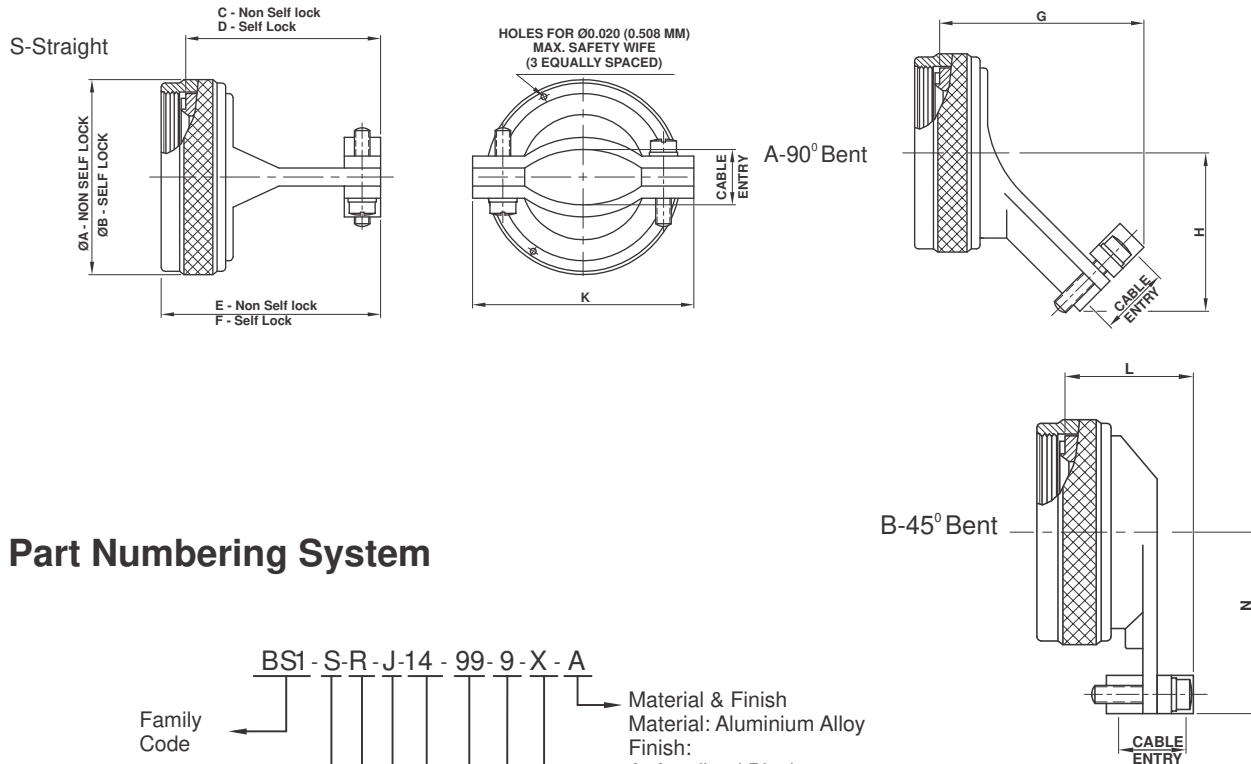

## Part Numbering System

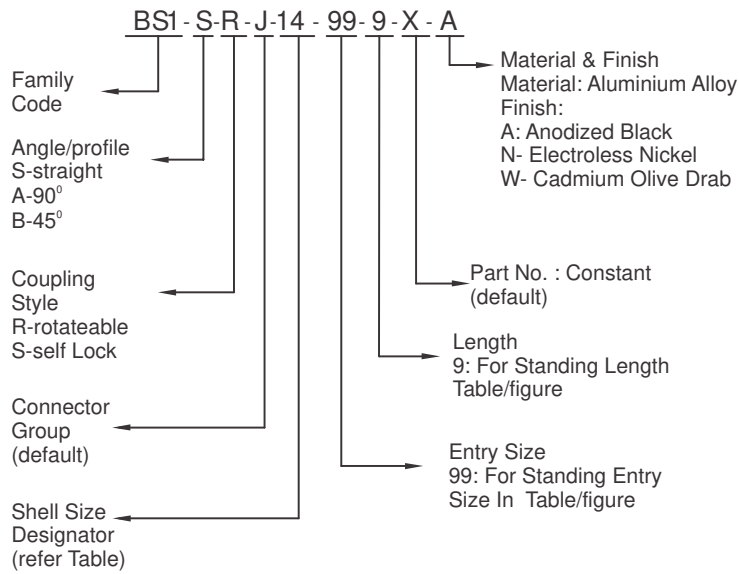

Table

SHELL SIZE DESIGNATOR	ØA MAX.		ØB MAX.		ØC MAX.		D MAX.		E MAX.		F MAX.		K MAX.		G MAX.		H MAX.		L MAX.		N MAX.		CABLE ENTRY							
	INCH	MM	INCH	MM	INCH	MM	INCH	MM	INCH	MM	INCH	MM	INCH	MM	INCH	MM	INCH	MM	INCH	MM	INCH	MM	INCH	MM	INCH	MM	INCH	MM		
08	0.617	15.67	0.885	22.48	0.63	16.00	0.73	18.54	0.890	22.61	1.04	26.42	0.782	19.86	1.320	33.53	0.772	19.61	0.93	23.62	0.808	20.52	0.204	5.18	0.187	4.75	0.286	7.26	0.187	4.75
10	0.734	18.64	1.010	25.65	0.74	18.80	0.85	21.59	1.000	25.40	1.16	29.46	0.862	21.89	1.364	34.65	0.803	20.40	1.02	25.91	0.867	22.02	0.286	7.26	0.187	4.75	0.286	7.26	0.187	4.75
12	0.858	21.79	1.135	28.83	0.86	21.84	0.98	24.89	1.125	28.58	1.29	32.77	1.003	25.48	1.438	36.53	0.866	22.00	1.21	30.73	0.929	23.60	0.416	10.57	0.291	7.39	0.416	10.57	0.291	7.39
14	0.984	24.99	1.260	32.00	0.86	21.84	0.98	24.89	1.125	28.58	1.29	32.77	1.061	26.95	1.480	37.59	0.928	23.57	1.27	32.26	0.992	25.20	0.476	12.09	0.351	8.92	0.476	12.09	0.351	8.92
16	1.112	28.24	1.385	35.18	0.99	25.15	1.10	27.94	1.250	31.75	1.41	35.81	1.334	33.88	1.586	40.28	0.991	25.17	1.42	36.07	1.056	26.82	0.626	15.90	0.501	12.73	0.626	15.90	0.501	12.73
18	1.218	30.94	1.510	38.35	1.24	31.50	1.35	34.29	1.500	38.10	1.66	42.16	1.466	37.24	1.704	43.28	1.110	28.19	1.53	38.86	1.233	31.32	0.706	17.93	0.518	13.16	0.706	17.93	0.518	13.16
20	1.345	34.16	1.635	41.53	1.36	34.54	1.48	37.59	1.625	41.28	1.79	45.47	1.572	39.93	1.748	44.40	1.172	29.77	1.65	41.91	1.296	32.92	0.831	21.11	0.581	14.76	0.831	21.11	0.581	14.76
22	1.468	37.29	1.760	44.70	1.49	37.85	1.60	40.64	1.750	44.45	1.91	48.51	1.688	42.88	1.792	45.52	1.235	31.37	1.78	45.21	1.358	34.49	0.956	24.28	0.644	16.36	0.956	24.28	0.644	16.36
24	1.593	40.46	1.885	47.88	1.61	40.89	1.73	43.94	1.875	47.63	2.04	51.82	1.790	45.47	1.836	46.63	1.297	32.94	1.90	48.26	1.420	36.07	1.081	27.46	0.706	17.93	1.081	27.46	0.706	17.93

Note: \* For ordering with Military part number contact factory.

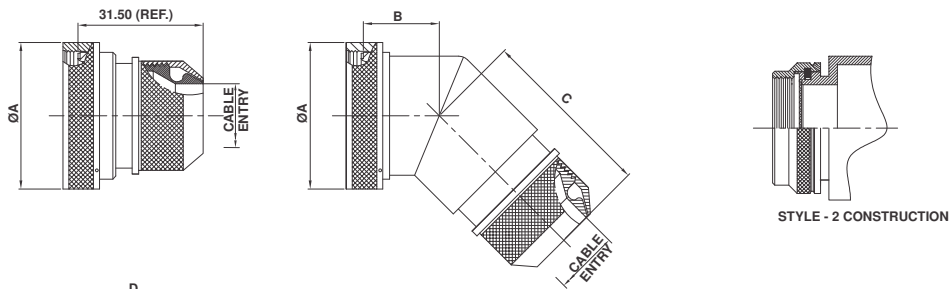

### Part Numbering System

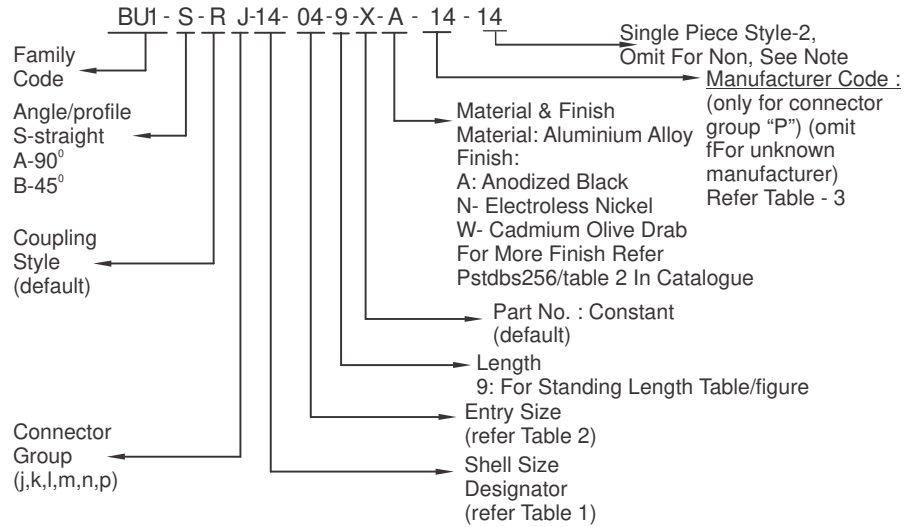

### Dimensions

SHELL SIZE DESIGNATOR	ØA MAX.		B MAX.		C MAX.		D MAX.		E MAX.	
	INCH	MM	NCH	MM	INCH	MM	INCH	MM	INCH	MM
08	0.885	22.48	0.87	22.10	1.12	28.46	1.12	28.52	1.39	35.50
10	1.01	25.65	0.90	22.90	1.15	29.22	1.11	28.40	1.46	37.09
12	1.135	28.83	0.92	23.40	1.17	29.74	1.18	30.20	1.53	38.94
14	1.28	32.51	0.94	24.10	1.20	30.50	1.24	31.70	1.59	40.50
16	1.41	35.81	0.98	24.90	1.22	31.01	1.25	31.90	1.65	42.12
18	1.52	38.61	1.00	25.50	1.23	31.26	1.32	33.78	1.75	44.53
20	1.64	41.66	1.01	25.75	1.26	32.02	1.33	33.90	1.77	45.12
22	1.77	44.96	1.03	26.40	1.29	32.79	1.31	35.37	1.83	46.72
24	1.89	48.01	1.07	27.20	1.31	33.29	1.39	35.50	1.89	48.00

ENTRY SIZE	Ø ENTRY (INCHES)	Ø ENTRY MM
01	$0.256^{+0.009}_{-0.018}$	6.50
02	0.315	8.00
03	0.375	9.50
04	0.437	11.10
05	0.500	12.70
06	0.626	15.90
07	0.748	19.00
08	0.876	22.25
09	1.000	25.40
10	1.126	28.60
11	1.250	31.75
12	1.378	35.00
13	1.500	38.10

Note: \* For ordering with Military part number contact factory.



# Environmental EMI/RFI Backshell

AMPHENOL PART NUMBER DESIGNATOR			A DIA. (MAX.)		B (MAX)		C (REF)		G (MAX)		CABLE RANGE			
SHELL SIZE	ENTRY SIZE	LENGTH	INCH		MM		INCH		MM		MIN		MAX	
			INCH	MM	INCH	MM	INCH	MM	INCH	MM	INCH	MM	INCH	MM
08	01	1	0.62	15.67	2.13	54.10	1.54	39.22	0.96	24.31	0.13	3.18	0.25	6.35
		2	0.62	15.67	3.13	79.50	1.54	39.22	0.96	24.31	0.13	3.18	0.25	6.35
	02	1	0.62	15.67	2.88	73.15	1.54	39.22	1.15	29.08	0.25	6.35	0.44	11.10
		2	0.62	15.67	3.88	98.55	1.54	39.22	1.15	29.08	0.25	6.35	0.44	11.10
10	01	1	0.73	18.64	2.13	54.10	1.54	39.22	0.96	24.31	0.13	3.18	0.31	7.92
		2	0.73	18.64	3.13	79.50	1.54	39.22	0.96	24.31	0.13	3.18	0.31	7.92
	02	1	0.73	18.64	2.88	73.15	1.54	39.22	1.15	29.08	0.25	6.35	0.44	11.10
		2	0.73	18.64	3.88	98.55	1.54	39.22	1.15	29.08	0.25	6.35	0.44	11.10
12	01	1	0.86	21.79	2.13	54.10	1.54	39.22	1.15	29.08	0.25	6.35	0.44	11.10
		2	0.86	21.79	3.13	79.50	1.54	39.22	1.15	29.08	0.25	6.35	0.44	11.10
	02	1	0.86	21.79	2.88	73.15	1.84	46.84	1.33	33.83	0.35	8.89	0.63	15.88
		2	0.86	21.79	3.88	98.55	1.84	46.84	1.33	33.83	0.35	8.89	0.63	15.88
14	01	1	0.98	24.99	2.13	54.10	1.84	46.84	1.33	33.83	0.35	8.89	0.58	14.61
		2	0.98	24.99	3.13	79.50	1.84	46.84	1.33	33.83	0.35	8.89	0.58	14.61
	02	1	0.98	24.99	2.88	73.15	1.92	48.67	1.55	39.40	0.50	12.70	0.75	19.05
		2	0.98	24.99	3.88	98.55	1.92	48.67	1.55	39.40	0.50	12.70	0.75	19.05
16	01	1	1.11	28.24	2.13	54.10	1.54	39.22	0.96	24.31	0.13	3.18	0.31	7.92
		2	1.11	28.24	3.13	79.50	1.54	39.22	0.96	24.31	0.13	3.18	0.31	7.92
	02	1	1.11	28.24	2.88	73.15	2.00	50.80	1.77	44.96	0.63	15.88	0.94	23.80
		2	1.11	28.24	3.88	98.55	2.00	50.80	1.77	44.96	0.63	15.88	0.94	23.80
18	01	1	1.11	28.24	2.13	54.10	1.54	39.22	1.15	29.08	0.25	6.35	0.44	11.10
		2	1.11	28.24	3.13	79.50	1.54	39.22	1.15	29.08	0.25	6.35	0.44	11.10
	02	1	1.11	28.24	2.88	73.15	2.00	50.80	1.77	44.96	0.63	15.88	0.94	23.80
		2	1.11	28.24	3.88	98.55	2.00	50.80	1.77	44.96	0.63	15.88	0.94	23.80
20	01	1	1.22	30.94	2.13	54.10	1.84	46.84	1.33	33.83	0.35	8.89	0.63	15.88
		2	1.22	30.94	3.13	79.50	1.84	46.84	1.33	33.83	0.35	8.89	0.63	15.88
	02	1	1.22	30.94	2.88	73.15	2.00	50.80	1.77	44.96	0.63	15.88	0.94	23.80
		2	1.22	30.94	3.88	98.55	2.00	50.80	1.77	44.96	0.63	15.88	0.94	23.80
22	01	1	1.35	34.16	4.13	104.90	1.84	46.84	1.33	33.83	0.35	8.89	0.63	15.88
		2	1.35	34.16	5.13	129.90	1.84	46.84	1.33	33.83	0.35	8.89	0.63	15.88
	02	1	1.35	34.16	3.13	79.50	1.92	48.67	1.55	39.40	0.50	12.70	0.75	19.05
		2	1.35	34.16	4.13	104.90	1.92	48.67	1.55	39.40	0.50	12.70	0.75	19.05
24	01	1	1.47	37.29	3.13	79.50	1.84	46.84	1.33	33.83	0.35	8.89	0.63	15.88
		2	1.47	37.29	4.13	104.90	1.84	46.84	1.33	33.83	0.35	8.89	0.63	15.88
	02	1	1.47	37.29	3.13	79.50	1.92	48.67	1.55	39.40	0.50	12.70	0.75	19.05
		2	1.47	37.29	4.13	104.90	1.92	48.67	1.55	39.40	0.50	12.70	0.75	19.05

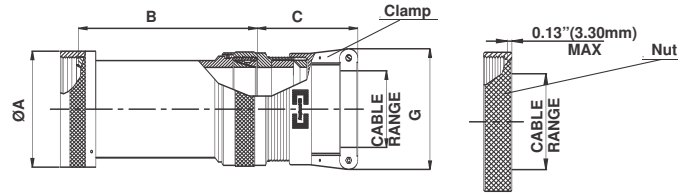

### Amphenol Part Number

**BV1-S - R-J - 18 - 02 - 2 - C - W**

- Series
- Angle: S-straight
- Coupling: R: Spin, D: Direct
- Connector Group
- End Clamp: C: clamp, N: nut
- Length: See Table A
- Entry Size: See Table A
- Shell Size: See Table A
- Finish: See Table 2

Note: \* For ordering with Military part number contact factory.



## Miniature Cylindrical MIL-DTL-26482, Series 2

MIL-DTL-26482, SERIES 2  
CRIMP CONTACTS

Contact Size	Wire Range		Socket Contacts	Pin Contacts
	AWG	mm <sup>2</sup>	Military Part Number	Military Part Number
20	24-20	0.2-0.6	M39029/5-115	M39029/4-110
16	20-16	0.5-1.4	M39029/5-116	M39029/4-111
12	14-12	2-3	M39029/5-118	M39029/4-113

### CONTACT CURRENT RATING AND RETENTION

Contact Size*	DC Test Amperage	Contact Retention	
		Axial Load	
		lb.	N
20	7.5	19.99	88.95
16	13.0	25	111.2
12	23.0	30	133.4

\*Operating individual circuits to maintain heat rise within operating temperature requirements.

### SEALING PLUGS

Contact Size	Sealing Plugs
	Military Part Number
20	MS27488-20
16	MS27488-16
12	MS27488-12

### CRIMPING TOOLS

Contact Size	Wire Range		Finished Wire Dia. Range		Crimping Tool Part Number	Turret or Positioner Part Number
	AWG	mm <sup>2</sup>	Inch	mm		
20	24-20	0.2-0.6	.040-.083	1.02-2.11	M22520/1-01 or M22520/2-01	M22520/1-02 or M22520/2-02
16	20-16	0.5-1.4	.053-.103	1.34-2.62	M22520/1-01	M22520/1-02
12	14-12	2-3	.097-.158	2.46-4.01	M22520/1-01	M22520/1-02

### INSERTION/REMOVAL TOOLS

Size	Color Code	Military Part Number
20	Red/White	M81969/14-11
16	Blue/White	M81969/14-03
12	Yellow/White	M81969/14-04

NOTE: Each connector is furnished with contacts. One spare for inserts requiring 1 to 20 of each contact, two spares for inserts with more than 26 contacts, and a minimum of one sealing plug up to 15% of the number of contacts.

### Metal Insertion & Extraction tool part no.

SR.NO	CONTACT SIZE	METAL INSERTION TOOL		METAL EXTRACTION TOOL	
		MILITARY NO.	DMC P/N	MILITARY NO.	DMC P/N
1	20	M81969/8-202	DAK83-20B	M81969/8-206	DAK83-20B
2	16	M81969/8-207	DAK83-16B	M81969/8-208	DAK83-16B
3	12	M81969/8-209	DAK83-12B	M81969/8-2010	DAK83-12B



	1.	2.	3.	4.	5.	6.	7.
MIL-DTL-26482 SERIES 2	CONNECTOR TYPE	CONNECTOR STYLE	SERVICE CLASS	SHELL SIZE/INSERT ARRANGEMENT	CONTACT TYPE	ALTERNATE ROTATION OF INSERT	MODIFICATION NUMBER
MILITARY	MS	3470	W	12-10	P	W	NA
COMMERCIAL	IMB1	0	W	12-10	P	W	(xxx)

### Step 1 Military Connector Type

<b>MS</b>	Designates Military Standard
-----------	------------------------------

### Step 1 Commercial Connector Type

<b>IMB1</b>	Designates Amphenol Bayonet Coupling Connector
-------------	--

### Step 2 Select a Connector Style

	Designates
3470	Wall Mount Receptacle with Narrow Flange
3471	Cable Connecting Receptacle
3472	Wall Mount Receptacle with Wide Flange
3474	Jam Nut Receptacle
3475	Straight Plug with RFI Grounding Fingers
3476	Straight Plug

### Step 2 Select a Connector Style

	Designates Military Standard
0	Wall Mount Receptacle with Narrow Flange
1	Cable Connecting Receptacle
2	Wall Mount Receptacle with Wide Flange
4	Jam Nut Receptacle
5	Straight Plug with RFI Grounding Fingers
6	Straight Plug

### Step 3 Select a Service Class

	Designates
L	Aluminum shell, electroless nickel finish, fluid resistant insert.
A	Aluminum shell, black anodized finish.
W	Aluminum shell, olive drab cadmium plated, fluid resistant insert.

### Step 3 Select a Service Class

	Designates
L	Aluminum shell, electroless nickel finish, fluid resistant insert.
A	Aluminum shell, black anodized.
W	Aluminum shell, olive drab cadmium plated, fluid resistant insert.

**Step 4 Select a Shell Size & Insert Arrangement** from chart on page Shell Size & Insert Arrangements are on pages 6-8 First number represents Shell Size, second number is the Insert Arrangement.

**Step 4 Select a Shell Size & Insert Arrangement** from chart on page Shell Size & Insert Arrangements are on pages 6-8 First number represents Shell Size, second number is the Insert Arrangement.

### Step 5 Select a Contact Type

	Designates
P	Pin Contacts
S	Socket
A	Less Pins
B	Less Sockets

Use A & B only when other than a full complement of power contacts is to be installed.

### Step 5 Select a Contact Type

	Designates
P	Pin Contacts
S	Socket Contacts

**Step 6 Select an Alternate Rotation of Insert** "W", "X", "Y", "Z" designate that insert is rotated in its shell from normal position. No letter required for normal (no rotation) position. See page for description of alternate positions.

**Step 6 Select an Alternate Rotation of Insert** "W", "X", "Y", "Z" designate that insert is rotated in its shell from normal position. No letter required for normal (no rotation) position. See page for description of alternate positions.

**Step 7 Modification Number**  
Consult Factory.



**Notes :**

**Notice :** All information, including illustrations given herein is believed to be accurate at the time of printing. In lieu of design advances, Amphenol reserves the right to change specifications without notice. This publication ACSE206-05-14, Series 2 supercedes all existing Amphenol literature on Series 2 Connectors.

## NORTH AMERICA

### Sales & Product Support

Amphenol PCD  
72 Cherry Hill Drive  
Beverly, MA 01915 USA  
Tel: +1-978-624-3400  
Fax: +1-978-927-1513  
info@amphenolpcd.com  
www.amphenolpcd.com  
www.backshellworld.com

Amphenol Aerospace Operations  
40-60, Delaware Avenue  
Sidney, NY 13838-1395  
Tel: +1-607-563-5011  
Fax: +1-607-563-5357

Amphenol Canada  
Meford Drive  
Scarborough,  
ON M1B 2X6  
Tel: +416-291-4401  
Fax: +416-292-0647

Amphenol Fiber Systems International  
1300 Central Expressway North  
Suite 100 Allen, Texas 75013, USA  
Tel: +1-214-547-2400  
Fax: +1-214-547-9344

## EUROPE

### France

Amphenol Socapex S.A.S.  
948, Promenade de l'Arve  
Bp29, Thyez Cedex  
74311, France  
Tel: +33-4-5089-2800  
Fax: +33-4-5096-1941

### United Kingdom

Amphenol Limited  
Thanet Way, Whitstable  
Kent CT5 3JF, England  
Tel: +44-1227-773-200  
Fax: 44-1227-276-571

### Germany

Amphenol-Air LB GmbH  
Am Kleinbahnhof 4  
Saarlouis  
D-66740, Germany  
Tel: 49-6831-9810-00  
Fax: 49-6831-9810-30

### Italy

Via Barbaiana 5  
20020 Lainate (Milano)  
Italy  
Tel: +39-02-93254.209  
+39-02-93254.214  
Fax: +39-02-93254-444

### Center & East Europe

Amphenol  
Wiener Gasse 68  
2380 Perchtoldsdorf  
Tel: +43-699-10396071  
Fax: +43 699 40396071

Amphenol Air-LB  
Immeuble Le Doublon  
11, Avenue Dobonnet  
Courbevoie-Cedex  
92407, France  
Ph: +33-1-4905-3000  
Fax: +33-1-4905-3043

### Spain

Amphenol Iberica  
Edificio Burgosol Oficina  
N 55 C/Comunidad de  
Madrid 35 bis -  
Las Rozas (Madrid)  
Tel: +34-91-6407302  
+34-91-6407306  
Fax: +34-91-6407307

### Austria

Amphenol Austria  
Wiener Gasse 68  
2380, Erchtoldsdarf,  
Austria  
Tel: + 43-69910396071  
Fax: + 43-69940306071

### Holland

Amphenol Benelux  
Zadelmaker 121  
NL-2401 PD Alphen  
aan den Rijn Holland  
Tel: +31-172-444903  
Fax: +31-172 240254

### Sweden

Amphenol  
Industrial and Military &  
Aerospace  
Nordic & Baltic  
Military Phone/  
Mobile+46702129200  
Industrial +46 767909560

## ASIA

### India

Amphenol Interconnect India Pvt. Ltd.  
105 Bhosari Industrial Area  
Pune-411026, India  
Tel: +91-20-3068-8305  
Fax: +91-20-2712-9158

Amphenol Interconnect India Pvt. Ltd.  
61 Electronics City  
Bangalore-560 100, India  
Ph: +91-80-2852-3838  
Fax: +91-80-2852-0418

### Japan

Amphenol Japan  
471-1, Deba, Ritto City  
Shiga 520-3041, Japan  
Tel: +81-77-553-8501  
Fax: +81-77-551-2200

### Korea

Amphenol Daeshin Electronics  
558 SoSa, SongNae, Bucheon-City  
Kyunggi-Do, Korea 420-130  
Tel: +82-32-610-3800  
Fax: +92-32-673-2507

### Singapore

Amphenol East Asia Ltd.  
72 Bendemeer Road  
# 03-33 Luzerne  
Singapore 339 941  
Tel: 65-6294-2128  
Fax: 65-6294-3522

### China

Amphenol PCD Shenzhen  
3/F Building, A4 Songbai  
Industrial Park  
East Road of Minghuan  
Gongming Town, Baon District  
Shenzhen, China  
Tel: +86-755-8173-8000  
Fax: +86-755-8173-8180

## ROW

### Australia

Amphenol Australia Pty Ltd  
2 Fiveways Boulevard  
Keysborough  
VIC 3173  
Ph: +61-3-8796-8888  
Fax: +61-3-8796-8801

### Israel

Bar-Tec Ltd.  
P.O. Box 279  
Kfar Sava, 44102 Israel  
Tel: +972-9-7644100  
Fax: +972-9-7674324

### Africa

Amphenol South Africa  
30 Impala Road  
2196 Sandton-Chistlehurst  
South Africa  
Tel: +27-11-783-9517  
Fax: +27-11-783-9519

### Maslak

34396 Istanbul  
Tel: +90-212-335-2501  
Fax: +90-212-335-2500

### Russia

Amphenol Russia  
8-2 Yaroslavskaja Str  
129164 Moscow, Russia  
Tel: +7-495-937-6341  
Fax: +7-495-937-6319

### Brazil

Amphenol do Brasil Ltda  
Rua Diogo Moreira 132  
CEP 05423-010  
Sao Paulo-SP, Brazil  
Tel: +55-11-3815-1003  
Fax: +55-11-3815-1629

### Argentina

Amphenol Argentina  
Avenida Callao 930  
2nd Floor, Office B Plaza  
C1023AAP Buenos Aires  
Argentina  
Tel: 54-11-4815-6886  
Fax: 54-11-4814-5779

# Amphenol

A Global Company



Pune Operations



Bangalore Operations

# Amphenol

Interconnect India Pvt. Ltd.

## Our offices in India:

### MARKETING HEADQUARTERS

105, Bhosari Industrial Area,  
Pune - 411 026.  
Tel.: 91- 020 - 67360303, 67360304  
Fax : 91 - 020 - 67360321  
Email : vbhavsar@amphenol-in.com  
sales@amphenol-in.com

### Southern Region

No. 1115, 22nd Main Road,  
11th Cross Sector-1, HSR Layout  
Bangalore 560 102  
Tel.: 91-80-49530341, 49530345  
Fax : 91-80-49538697  
Email : kmanoj@amphenol-in.com

### Northern and Eastern Region

A-421, Pacific Business Park  
Plot No. 37/1, Sahibabad Indst. Area, Site IV,  
Ghaziabad (UP) - 201 010.  
Mobile : 91-9910211399  
Email : sunily@amphenol-in.com

### Export

105, Bhosari Industrial Area,  
Pune - 411 026, India.  
Tel.: 91- 20 - 67360305, 67360353  
Fax : 91- 20 - 67360321  
Email : svpatil@amphenol-in.com

### Western Region

105, Bhosari Industrial Area,  
Pune - 411 026.  
Tel.: 91-20-67360334  
Email : sunilp@amphenol-in.com

### Central Region

107, 1st Floor, 'Am Sri Classic',  
Sarojinidevi Road, Secunderabad-500 003.  
Telefax : 91- 40-66332906  
Email : pprasad@amphenol-in.com

### Kolkatta

Mobile: 91- 9831533335  
Email : rajeshd@amphenol-in.com

### Chennai

Mobile: 91- 9940039373  
Email : subashs@amphenol-in.com

[www.amphenol-in.com](http://www.amphenol-in.com)