

NOTES:

- FOR WAVESOLDERING (SOLDER BATH TEMPERATURE 240°C FOR 5 SEC. AND SOLDER PREHEAT 120°C FOR 120 SEC.)
- METAL SHELLS: COPPER ALLOY; min. 315µm TIN over 40-80µm NICKEL
- INSULATORS: PBT GF UL 94 V-0, BLACK
- CONTACTS: COPPER ALLOY
PLATING: GOLD FLASH over NICKEL
- THREADED REAR SPACER CLIP: COPPER ALLOY;
min. 200µm TIN over 80µm NICKEL
PCB-HOLE: Ø3,1±0,1; THICKNESS 1,6mm
- COLLARS: COPPER ALLOY; min. 200µm TIN over 80µm NICKEL
- FRAME: ZINC DIE CAST; NICKEL PLATED
- HEXLOCKING SCREW: STAINLESS STEEL
- O-RING: SILICON; BLUE
- SEALING COMPOUND: PUR; BLUE
- P.C.B. HOLE DRILLINGS AND RECOMMENDED PANEL CUT-OUT ON SHEET 2
- RECOMMENDED TORQUE FOR MOUNTING SCREW 35Ncm (3,1 in.LB) / max. 40Ncm (3,5 in. LB)
- CONNECTOR IS PART MARKED: 6STD50SAR99E20X CONEC ABC

AT ALL TIMES WATER RESISTANT CONNECTORS NOT IN USE SHOULD BE COVERED WITH A CONEC WATER RESISTANT CAP OR WATER TIGHT HOOD.

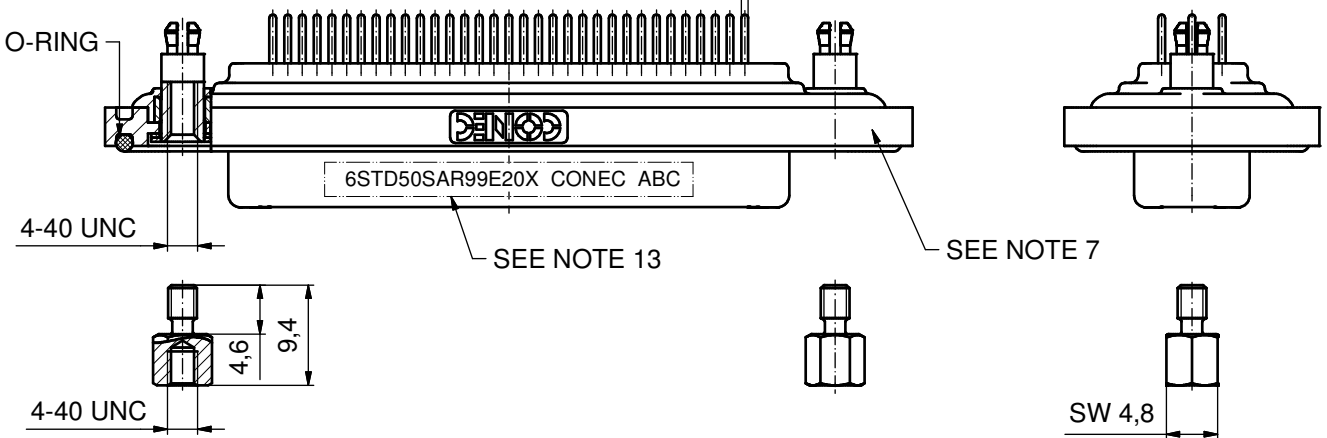
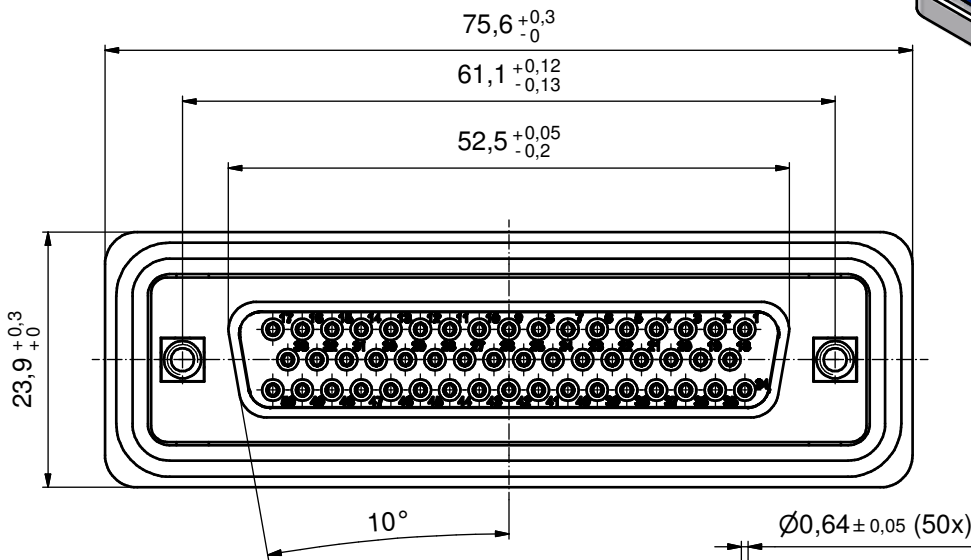
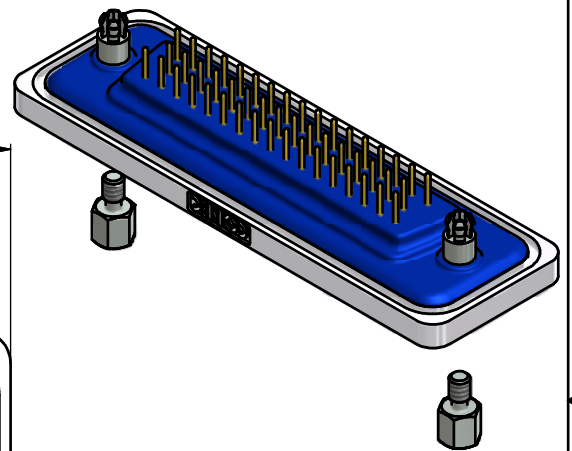
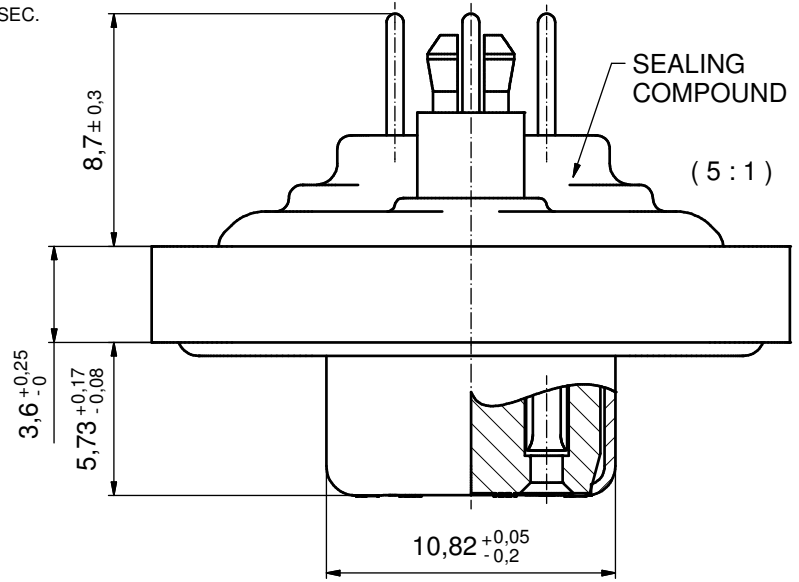

Directive 2002/95/EC RoHS compliant

THIS DRAWING MAY NOT BE COPIED OR REPRODUCED IN ANY WAY, AND MAY NOT BE PASSED ON TO A THIRD PARTY WITHOUT WRITTEN PERMISSION. OWNERSHIP AND COPYRIGHT OF CONEC GmbH DO NOT ALTER CAD DRAWING BY HAND	tolerance		dim. in mm		scale: 2:1 (5:1)
			date	name	material: SEE NOTES
	drawn	20.03.12	Henneboel		title: D-SUB FEMALE 50pos. SOLDER PIN STRAIGHT with threaded spacer clip and hexlocking screw
	appd.	21.03.12	Fischer		
	norm				
d-old					
a	Original			dwg no: 15K2A489	DIN-A3
rev.	description			date	name
				part no: 6STD50SAR99E20X	

P.C.B. HOLE DRILLINGS
(P.C.B. TOP SIDE)

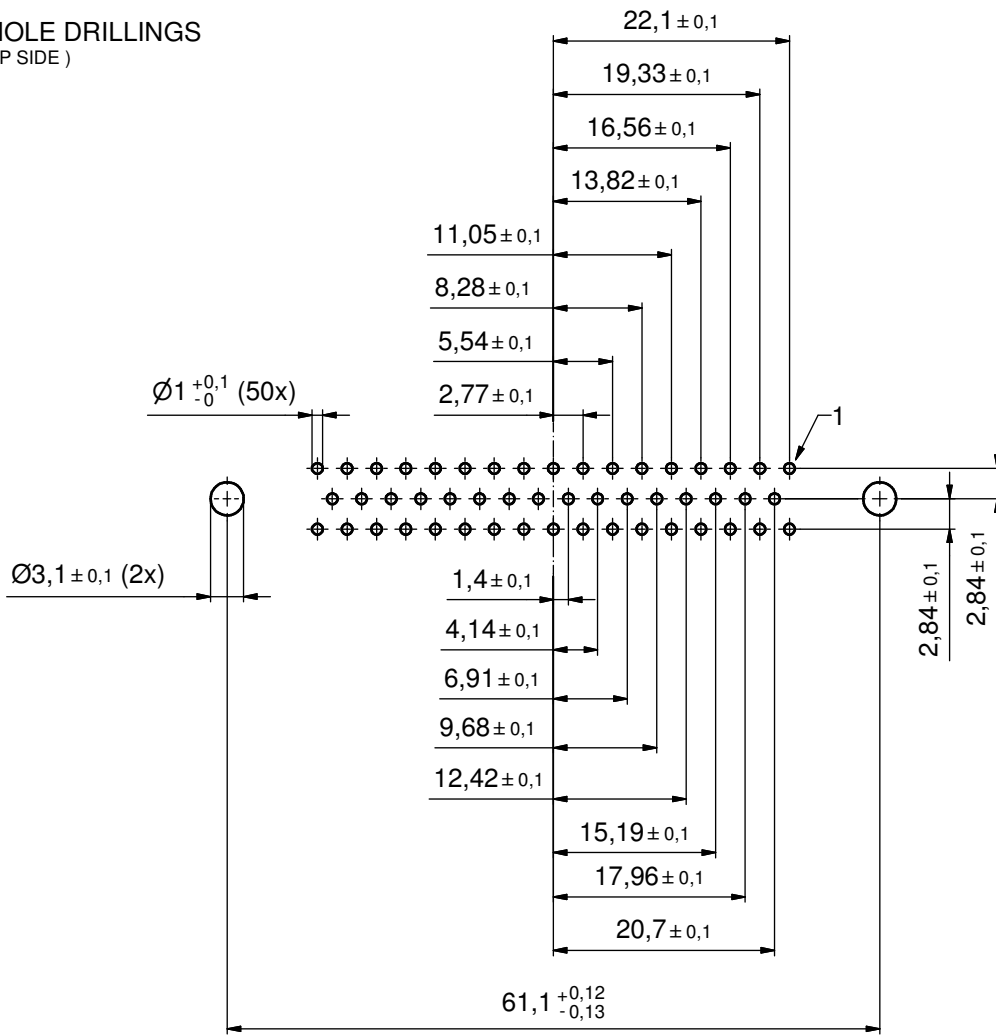

RECOMMENDED PANEL CUT-OUT

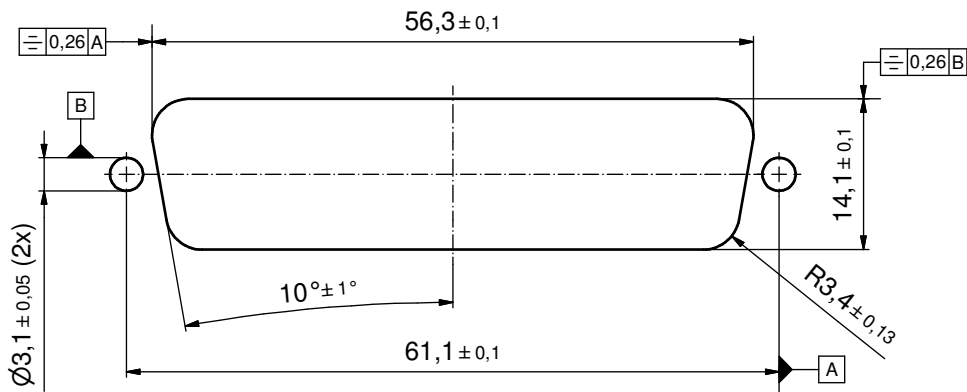

THIS DRAWING MAY NOT BE COPIED OR REPRODUCED IN ANY WAY, AND MAY NOT BE PASSED ON TO A THIRD PARTY WITHOUT WRITTEN PERMISSION. OWNERSHIP AND COPYRIGHT OF CONEC GmbH DO NOT ALTER CAD DRAWING BY HAND				tolerance		scale: 2:1
				date	name	material: SEE SHEET 1
				drawn	20.03.12	Henneboel
				appd.	21.03.12	Fischer
				norm		
			d-old			
			a	Original		title: P.C.B. HOLE DRILLINGS PANEL CUT-OUT D-SUB FEMALE 50pos. Solder pin straight
rev.	description	date	name	CONEC [®]		dwg no: 15K2A489
						part no: SEE SHEET 1
						DIN-A3 sh: 2