

PART NUMBER	REV	FIRST USED
680620-1	B	122500-1
680620-2	B	565435-5

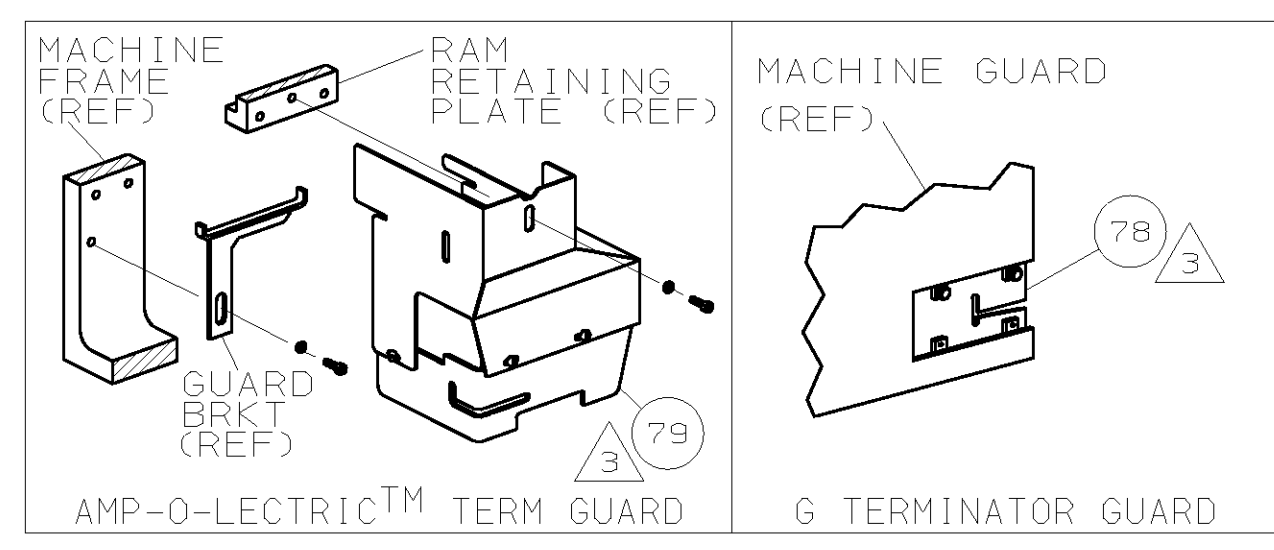

TERMINAL NAME: SOCKET		CRIMP DATA (NON-AMP TERMINAL-AMP SPEC)			
AMP	MFG P/N	PAD LTR	CRIMP HEIGHT	WIRE SIZE	
286709	250-9019	A	.047 ±.002 [1.19 ±0.05mm]	18	
		B	.043 ±.002 [1.09 ±0.05mm]	20	
		C	NOT	USED	
		D	NOT	USED	
		CRIMP	SIZE	TYPE	
		WIRE	.120 [3.05mm]	F	
		INSUL	.130 [3.30mm]	F	
				.080-.110	
WIRE STRIP LENGTH	TERM APPL SPEC	FEED	APPL INSTRUCTION	SET UP GAGE	LAYOUT
.140-.172	NONE	.733	408-8039	458638-1	L2066

LEADMAKER & BENCH MODEL G		MECH POST FEED			
REF	REF	-	A	22594-8	NUT, HEX
REF	REF	-	B	240628-1	PLATE, ADJ
REF	REF	-	B	240626-1	SHAFT, PIVOT
REF	REF	-	B	240633-1	BUSHING
REF	REF	-	A	455680-1	LEVER, INTERMEDIATE
REF	REF	-	B	240629-1	BLOCK, PIVOT
REF	REF	-	A	240632-2	SCR, ADJ
REF	REF	-	B	240659-3	PIN, CAM ROLLER
REF	REF	-	B	240658-1	CAM, ROLLER
REF	REF	-	B	454398-1	ROD, FEED
REF	REF	-	C	454220-1	CAP, RAM
REF	REF	-	D	453736-1	HOUSING
REF	REF	-	B	240624-1	PIN, FEED FINGER
REF	REF	-	B	691499-1	SPRING, FEED FINGER
REF	REF	-	B	240635-1	FINGER, FEED
REF	REF	-	B	240634-1	LEVER, TERMINAL
REF	REF	-	C	454220-1	CAP, RAM
REF	REF	-	D	453736-1	HOUSING
REF	REF	-	B	690501-3	CAM, POST FEED 1 1/8 ST
REF	REF	-	B	690501-4	CAM, POST-FEED 1 5/8 ST
REF	REF	-	A	690191-1	PLUG, NYLON
REF	REF	-	C	455674-1	RAM
REF	REF	-	A	690125-1	WASHER, LAMINATED
REF	REF	-	A	690124-1	WASHER, RAM
REF	REF	-	A	7-21002-9	BOLT, CRIMPER (5/16-24x1.00)
REF	REF	-	A	23241-6	BALL, STEEL
REF	REF	-	A	690170-1	SPRING, COMPRESSION
REF	REF	-	C	690142-1	DISC, INSULATION
REF	REF	-	D	354777-1	WIRE DISC, PLASTIC
REF	REF	-	A	22480-5	WASHER, SPRING
REF	REF	-	B	690212-1	POST, RAM
REF	REF	-	A	690191-1	PLUG, NYLON
REF	REF	-	C	455674-1	RAM
REF	REF	-	A	690125-1	WASHER, LAMINATED
REF	REF	-	A	690124-1	WASHER, RAM
REF	REF	-	A	7-21002-9	BOLT, CRIMPER (5/16-24x1.00)
REF	REF	-	A	23241-6	BALL, STEEL
REF	REF	-	A	690170-1	SPRING, COMPRESSION
REF	REF	-	C	690142-1	DISC, INSULATION
REF	REF	-	D	354777-1	WIRE DISC, PLASTIC
REF	REF	-	A	22480-5	WASHER, SPRING
REF	REF	-	B	690212-1	POST, RAM
REF	REF	-	A	690191-1	PLUG, NYLON
REF	REF	-	C	455674-1	RAM
REF	REF	-	A	690125-1	WASHER, LAMINATED
REF	REF	-	A	690124-1	WASHER, RAM
REF	REF	-	A	7-21002-9	BOLT, CRIMPER (5/16-24x1.00)
REF	REF	-	A	23241-6	BALL, STEEL
REF	REF	-	A	690170-1	SPRING, COMPRESSION
REF	REF	-	C	690142-1	DISC, INSULATION
REF	REF	-	D	354777-1	WIRE DISC, PLASTIC
REF	REF	-	A	22480-5	WASHER, SPRING
REF	REF	-	B	690212-1	POST, RAM
REF	REF	-	A	690191-1	PLUG, NYLON
REF	REF	-	C	455674-1	RAM
REF	REF	-	A	690125-1	WASHER, LAMINATED
REF	REF	-	A	690124-1	WASHER, RAM
REF	REF	-	A	7-21002-9	BOLT, CRIMPER (5/16-24x1.00)
REF	REF	-	A	23241-6	BALL, STEEL
REF	REF	-	A	690170-1	SPRING, COMPRESSION
REF	REF	-	C	690142-1	DISC, INSULATION
REF	REF	-	D	354777-1	WIRE DISC, PLASTIC
REF	REF	-	A	22480-5	WASHER, SPRING
REF	REF	-	B	690212-1	POST, RAM
REF	REF	-	A	690191-1	PLUG, NYLON
REF	REF	-	C	455674-1	RAM
REF	REF	-	A	690125-1	WASHER, LAMINATED
REF	REF	-	A	690124-1	WASHER, RAM
REF	REF	-	A	7-21002-9	BOLT, CRIMPER (5/16-24x1.00)
REF	REF	-	A	23241-6	BALL, STEEL
REF	REF	-	A	690170-1	SPRING, COMPRESSION
REF	REF	-	C	690142-1	DISC, INSULATION
REF	REF	-	D	354777-1	WIRE DISC, PLASTIC
REF	REF	-	A	22480-5	WASHER, SPRING
REF	REF	-	B	690212-1	POST, RAM
REF	REF	-	A	690191-1	PLUG, NYLON
REF	REF	-	C	455674-1	RAM
REF	REF	-	A	690125-1	WASHER, LAMINATED
REF	REF	-	A	690124-1	WASHER, RAM
REF	REF	-	A	7-21002-9	BOLT, CRIMPER (5/16-24x1.00)
REF	REF	-	A	23241-6	BALL, STEEL
REF	REF	-	A	690170-1	SPRING, COMPRESSION
REF	REF	-	C	690142-1	DISC, INSULATION
REF	REF	-	D	354777-1	WIRE DISC, PLASTIC
REF	REF	-	A	22480-5	WASHER, SPRING
REF	REF	-	B	690212-1	POST, RAM
REF	REF	-	A	690191-1	PLUG, NYLON
REF	REF	-	C	455674-1	RAM
REF	REF	-	A	690125-1	WASHER, LAMINATED
REF	REF	-	A	690124-1	WASHER, RAM
REF	REF	-	A	7-21002-9	BOLT, CRIMPER (5/16-24x1.00)
REF	REF	-	A	23241-6	BALL, STEEL
REF	REF	-	A	690170-1	SPRING, COMPRESSION
REF	REF	-	C	690142-1	DISC, INSULATION
REF	REF	-	D	354777-1	WIRE DISC, PLASTIC
REF	REF	-	A	22480-5	WASHER, SPRING
REF	REF	-	B	690212-1	POST, RAM
REF	REF	-	A	690191-1	PLUG, NYLON
REF	REF	-	C	455674-1	RAM
REF	REF	-	A	690125-1	WASHER, LAMINATED
REF	REF	-	A	690124-1	WASHER, RAM
REF	REF	-	A	7-21002-9	BOLT, CRIMPER (5/16-24x1.00)
REF	REF	-	A	23241-6	BALL, STEEL
REF	REF	-	A	690170-1	SPRING, COMPRESSION
REF	REF	-	C	690142-1	DISC, INSULATION
REF	REF	-	D	354777-1	WIRE DISC, PLASTIC
REF	REF	-	A	22480-5	WASHER, SPRING
REF	REF	-	B	690212-1	POST, RAM
REF	REF	-	A	690191-1	PLUG, NYLON
REF	REF	-	C	455674-1	RAM
REF	REF	-	A	690125-1	WASHER, LAMINATED
REF	REF	-	A	690124-1	WASHER, RAM
REF	REF	-	A	7-21002-9	BOLT, CRIMPER (5/16-24x1.00)
REF	REF	-	A	23241-6	BALL, STEEL
REF	REF	-	A	690170-1	SPRING, COMPRESSION
REF	REF	-	C	690142-1	DISC, INSULATION
REF	REF	-	D	354777-1	WIRE DISC, PLASTIC
REF	REF	-	A	22480-5	WASHER, SPRING
REF	REF	-	B	690212-1	POST, RAM
REF	REF	-	A	690191-1	PLUG, NYLON
REF	REF	-	C	455674-1	RAM
REF	REF	-	A	690125-1	WASHER, LAMINATED
REF	REF	-	A	690124-1	WASHER, RAM
REF	REF	-	A	7-21002-9	BOLT, CRIMPER (5/16-24x1.00)
REF	REF	-	A	23241-6	BALL, STEEL
REF	REF	-	A	690170-1	SPRING, COMPRESSION
REF	REF	-	C	690142-1	DISC, INSULATION
REF	REF	-	D	354777-1	WIRE DISC, PLASTIC
REF	REF	-	A	22480-5	WASHER, SPRING
REF	REF	-	B	690212-1	POST, RAM
REF	REF	-	A	690191-1	PLUG, NYLON
REF	REF	-	C	455674-1	RAM
REF	REF	-	A	690125-1	WASHER, LAMINATED
REF	REF	-	A	690124-1	WASHER, RAM
REF	REF	-	A	7-21002-9	BOLT, CRIMPER (5/16-24x1.00)
REF	REF	-	A	23241-6	BALL, STEEL
REF	REF	-	A	690170-1	SPRING, COMPRESSION
REF	REF	-	C	690142-1	DISC, INSULATION
REF	REF	-	D	354777-1	WIRE DISC, PLASTIC
REF	REF	-	A	22480-5	WASHER, SPRING
REF	REF	-	B	690212-1	POST, RAM
REF	REF	-	A	690191-1	PLUG, NYLON
REF	REF	-	C	455674-1	RAM
REF	REF	-	A	690125-1	WASHER, LAMINATED
REF	REF	-	A	690124-1	WASHER, RAM
REF	REF	-	A	7-21002-9	BOLT, CRIMPER (5/16-24x1.00)
REF	REF	-	A	23241-6	BALL, STEEL
REF	REF	-	A	690170-1	SPRING, COMPRESSION
REF	REF	-	C	690142-1	DISC, INSULATION
REF	REF	-	D	354777-1	WIRE DISC, PLASTIC
REF	REF	-	A	22480-5	WASHER, SPRING
REF	REF	-	B	690212-1	POST, RAM
REF	REF	-	A	690191-1	PLUG, NYLON
REF	REF	-	C	455674-1	RAM
REF	REF	-	A	690125-1	WASHER, LAMINATED
REF	REF	-	A	690124-1	WASHER, RAM
REF	REF	-	A	7-21002-9	BOLT, CRIMPER (5/16-24x1.00)
REF	REF	-	A	23241-6	BALL, STEEL
REF	REF	-	A	690170-1	SPRING, COMPRESSION
REF	REF	-	C	690142-1	DISC, INSULATION
REF	REF	-	D	354777-1	WIRE DISC, PLASTIC
REF	REF	-	A	22480-5	WASHER, SPRING
REF	REF	-	B	690212-1	POST, RAM
REF	REF	-	A	690191-1	PLUG, NYLON
REF	REF	-	C	455674-1	RAM
REF	REF	-	A	690125-1	WASHER, LAMINATED
REF	REF	-	A	690124-1	WASHER, RAM
REF	REF	-	A	7-21002-9	BOLT, CRIMPER (5/16-24x1.00)
REF	REF	-	A	23241-6	BALL, STEEL
REF	REF	-	A	690170-1	SPRING, COMPRESSION
REF	REF	-	C	690142-1	DISC, INSULATION
REF	REF	-	D	354777-1	WIRE DISC, PLASTIC
REF	REF	-	A	22480-5	WASHER, SPRING
REF	REF	-	B	690212-1	POST, RAM
REF	REF	-	A	690191-1	PLUG, NYLON
REF	REF	-	C	455674-1	RAM
REF	REF	-	A	690125-1	WASHER, LAMINATED
REF	REF	-	A	690124-1	WASHER, RAM
REF	REF	-	A	7-21002-9	BOLT, CRIMPER (5/16-24x1.00)
REF	REF	-	A	23241-6	BALL, STEEL
REF	REF	-	A	690170-1	SPRING, COMPRESSION
REF	REF	-	C	690142-1	DISC, INSULATION
REF	REF	-	D	354777-1	WIRE DISC, PLASTIC
REF	REF	-	A	22480-5	WASHER, SPRING
REF	REF	-	B	690212-1	POST, RAM
REF	REF	-	A	690191-1	PLUG, NYLON
REF	REF	-	C	455674-1	RAM
REF	REF	-	A	690125-1	WASHER, LAMINATED
REF	REF	-	A	690124-1	WASHER, RAM
REF	REF	-	A	7-21002-9	BOLT, CRIMPER (5/16-24x1.00)