

LQ038Q5DR01

TFT-LCD Module

Spec. Issue Date: August 4, 2005

No: LCY-00044D

PREPARED BY: DATE <i>A. Inoue Aug. 04. 2005</i>	SHARP MOBILE LIQUID CRYSTAL DISPLAY GROUP SHARP CORPORATION SPECIFICATION	SPEC No. LCY-00044D
APPROVED BY: DATE <i>J. Semoto Aug. 04. 2005</i>		FILE No.
		ISSUE: Aug. 4. 2005
		PAGE: 21 pages
		MOBILE LCD DESIGN CENTER MOBILE LIQUID CRYSTAL DISPLAY GROUP

DEVICE SPECIFICATION FOR

TFT - LCD module

MODEL No. LQ038Q5DR01

CUSTOMER'S APPROVAL

DATE _____

BY _____

PRESENTED

BY *H. Yakushigawa*
H.YAKUSHIGAWA
Department General manager
Engineering Department.2
Mobile LCD Design Center I
Mobile Liquid Crystal Display Group
SHARP CORPORATION

RECORDS OF REVISION

MODEL No : LQ038Q5DR01

SPEC No : LCY-00044

	NO.	PAGE	SUMMARY	NOTE
2000.4.14		-	-	1 st Issue
2001.6.6	A	1	NOTICE [Addition]	2 nd Issue
		4	Lamp in the devices contain amount of mercury 【Note5-2】 [Change]	
			Ta ≤ 65°C → Ta ≤ 60°C	
		6	Backlight driving section [Addition]	
			Caution of Lamp voltage and current wave form	
		1 1	【Note9-7】 [Deletion]	
			Caution of Lamp voltage and current wave form	
		1 6	Table 14 No.5 [Change]	
			Test condition Tp=- 30°C → Ta=- 30°C	
2003.2.18	B	3	to modify the name of used connector from KX14-40K5D1 to KX14-40K5D-VI. to modify the name of fit connector from KX15-40K*D1 to KX15-40K*D-VI,KX15-40K*D1 or KX15-40KLDL.	3 rd Issue
2005.5.13	C	-	Adapted RoHs direction [Change]	4 th Issue
		1 5	Adapted lead free PWB & Lamp Indicatin of lot number label [Change]	
			LQ038Q5DR01 T → LQ038Q5DR01 A	
2005.8.4	D	3 , 17	to modify the name of used connector from KX14-40K5D-VI to KX14-40K5D-VIE. Adapted RoHs direction [Change]	5 th Issue
		14	Carton size [Correction]	
			483(W)× 166 (H) × 314 (D) mm → 503(W)× 166 (H) × 338 (D) mm	
			Total mass of one carton filled with full Modules. 7.7kg→7.5kg	

NOTICE

This publication is the proprietary of SHARP and is copyrighted, with all rights reserved. Under the copyright laws, no part of this publication may be reproduced or transmitted in any form or by any means, electronic or mechanical for any purpose, in whole or in part, without the express written permission of SHARP. Express written permission is also required before any use of this publication may be made by a third party.

The application circuit examples in this publication are provided to explain the representative applications of SHARP's devices and are not intended to guarantee any circuit design or permit any industrial property right or other rights to be executed. SHARP takes no responsibility for any problems related to any industrial property right or a third party resulting from the use of SHARP's devices, except for those resulting directly from device manufacturing processes.

In the absence of confirmation by device specification sheets, SHARP takes no responsibility for any defects that occur in equipment using any of SHARP's devices, shown in catalogs, data books, etc. Contact SHARP in order to obtain the latest device specification sheets before using any SHARP's device.

SHARP reserves the right to make changes in the specifications, characteristics, data, materials, structures and other contents described herein at any time without notice in order to improve design or reliability. Contact SHARP in order to obtain the latest specification sheets before using any SHARP's device. Manufacturing locations are also subject to change without notice.

Observe the following points when using any device in this publication. SHARP takes no responsibility for damage caused by improper use of the devices.

The devices in this publication are designed for use in general electronic equipment designs, such as:

- Car Navigation system
- Automotive auxiliary information display
- Automotive audio visual equipment

The appropriate design measures should be taken to ensure reliability and safety when SHARP's devices are used for equipment such as:

- Transportation control and safety equipment (i.e., aircraft, trains, automobiles, etc.)
- Traffic signals
- Gas leakage sensor breakers
- Alarm equipment
- Various safety devices etc.

SHARP's devices shall not be used for equipment that requires extremely high level of reliability, such as:

- Military and space applications
- Nuclear power control equipment
- Medical equipment for life support

Cold Cathode Fluorescent Lamp in the devices contain amount of mercury .
Please follow local ordinances or regulations for disposal.

Contact a SHARP representative, in advance, when intending to use SHARP's devices for any "specific" applications other than those recommended by SHARP.

Contact and consult with a SHARP representative if there are any questions about the contents of this publication.

(1) Application

This specification literature applies to color TFT-LCD module , LQ038Q5DR01.

(2) Summary and Features

- This module is a color active matrix LCD module incorporating amorphous silicon TFT (Thin Film Transistor).
- It is composed of a color TFT-LCD panel, driver ICs, control-PWB, FPC, frame, front shielding case, back-light unit.
- Graphics and texts can be displayed on a 320× 3× 240 dots panel with 262,144 colors by supplying. DC/AC inverter isn't composed.
- The 3.8 screen produces a high resolution image that is composed of 76,800 pixel elements in a stripe arrangement.
- Wide viewing angle technology is employed. (The most suitable viewing angle is in the 6 o'clock direction.)
- By adopting an active matrix drive, a picture with high contrast is realized.
- Through the use of TN-normally white mode, an image with highly natural color image is realized.
- It is used the Low-reflection (LR) and an antiglare (AG) surface polarization plate.
- An inverted video display in the vertical and horizontal directions is possible.

(3) Mechanical specifications

table 3-1

Parameter	Specifications	Units	Remarks
Display format	76,800	pixels	
	320(W)× RGB× 240(H)	dots	
Active area	78.72 (W) × 53.64 (H)	mm	
Screen size (Diagonal)	9.6 [3.8 Φ]	cm	
Dot pitch	0.082 (W) × 0.2235 (H)	mm	
Pixel configuration	R,G,B Stripe configuration		
Outline dimension	117.6× 69.45× 13.45	mm	【Note3-1】
Mass	125± 10	g	
Surface treatment	AG+LR		

【Note 3-1】

Typical values are given. For detailed measurements and tolerances, please refer to Fig. 1.

(4) Input terminal

4-1) TFT-LCD panel driving part

Used connector :KX14-40K5D-VIE(JAE Co. , Ltd)

Fit connector :KX15-40K *D-VI , KX15-40K *D1 or KX15-40KLDL (JAE Co. , Ltd)
(lock type) : * :2,3,...

Table 4-1

CN1 【Note4-4】

Pin No.	Symbol	Description	Remarks
1	G N D	ground	
2	V C C	Power supply voltage	
3	Hsync	Horizontal synchronous signal	【Note4-1】
4	G 3	GREEN data signal	
5	T 0	thermistor output1	
6	G 4	GREEN data signal	
7	T 1	thermistor output2	
8	G 5	GREEN data signal(MSB)	
9	H V R	Selection for horizontal and vertical scanning direction	【Note4-3】
1 0	G N D	ground	
1 1	G N D	ground	
1 2	B 0	BLUE data signal(LSB)	
1 3	C L K	Clock signal for sampling each data signal	
1 4	B 1	BLUE data signal	
1 5	G N D	ground	
1 6	B 2	BLUE data signal	
1 7	R 0	RED data signal(LSB)	
1 8	G N D	ground	
1 9	R 1	RED data signal	
2 0	B 3	BLUE data signal	
2 1	R 2	RED data signal	
2 2	B 4	BLUE data signal	
2 3	G N D	ground	
2 4	B 5	BLUE data signal(MSB)	
2 5	R 3	RED data signal	
2 6	G N D	ground	
2 7	R 4	RED data signal	
2 8	Vsync	Vertical synchronous signal	【Note4-1】
2 9	R 5	RED data signal(MSB)	
3 0	T E S T	Open use only	
3 1	G N D	Ground	
3 2	T E S T	Open use only	
3 3	G 0	GREEN data signal(LSB)	
3 4	T E S T	Open use only	
3 5	G 1	GREEN data signal	
3 6	T E S T	Open use only	
3 7	G 2	GREEN data signal	
3 8	E N A B	Signal to settle the horizontal display position	【Note4-2】
3 9	V C C	Power supply voltage	
4 0	G N D	ground	

【Note 4-1】

Hsync	positive
Vsync	positive

【Note 4-2】

The horizontal display start timing is settled in accordance with a rising timing of ENAB signal. In case ENAB is fixed “Low”, the horizontal start timing is determined as described in Fig3-A.

(Don't keep ENAB “High” during operation.(Fig3-B).)

【Note 4-3】

HVR = "Low" : Regular video

HVR = "High" : Horizontally and Vertically inverted video

【Note 4-4】

The position of pin number

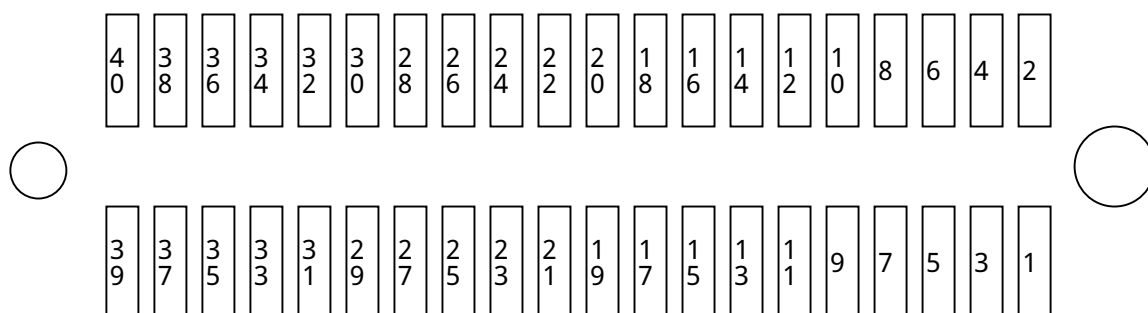

4-2) Back-light fluorescent tube driving part

Used connector:BHR-02(8.0)VS-1N(JST Co. ,Ltd)

Fit connctor:SM02(8.0)B-BHS-1N(JST Co. ,Ltd)

Table 4-2

No.	Symbol	i/o	Function	Color of FL cable
1	VL1	I	input terminal (High Voltage)	RED
2	VL2	I	input terminal (Low Voltage)	BLACK

Used thermistor :203GT- 1(Ishizuka electronics Corporation)=20.0kΩ ± 3 %

(5) Absolute maximum ratings

Table 5-1

GND = 0 V

Parameter	Symbol	MIN	MAX	Unit	Note
Input voltage	V _I	-0.3	VCC+0.3	V	【Note 5-1】 Ta=25°C
+3.3V power supply	VCC	0	5.5	V	Ta=25°C
Storage temperature	T _{stg}	-40	+95	°C	【Note 5-2】
Operating temperature (panel surface)	T _{opr1}	-30	+85	°C	【Note 5-2】
Operating temperature (Ambient temperature)	T _{opr2}	-30	+60	°C	【Note 5-2】

【Note 5-1】 CK,R0 ~ R5,G0 ~ G5,B0 ~ B5,Hsync,Vsync,ENAB,HVR

【Note 5-2】 Humidity:95%RH Max. at Ta ≤ 60°C

Maximum wet-bulb temperature is less than at 58°C at Ta>60°C.

Condensation of dew must be avoided as electrical current leaks will occur, causing a

Degradation of performance specifications.

(6) Electrical characteristics

6-1) TFT-LCD panel driving section

Table 6-1

GND = 0 V , T a = 2 5 °C

Parameter		Symbol	MIN	TYP	MAX	Unit	Remarks
+3.3V	Supply voltage	Vcc	+2.9	+3.3	+3.7	V	【Note 6-1】
	Current dissipation	I cc	-	140	180	mA	【Note 6-2,3】
Permissive input ripple		V _{RF}	-	-	100	mV _{pp}	
Input Low voltage		V _{IL}	-	-	0.3VCC	V	【Note 6-4】
Input High voltage		V _{IH}	0.7VCC	-	-	V	
Input current (Low)		I _{IL}	-	-	1.0	μ A	V _I =0V 【Note 6-5】
Input current (High)		I _{IH}	3.0	-	75	μ A	V _I =VCC 【Note 6-5】
Input current (Low)		I _{IL}	3.0	-	75	μ A	V _I =0V 【Note 6-6】
Input current (High)		I _{IH}	-	-	1.0	μ A	V _I =VCC 【Note 6-6】
Input current (Low)		I _{IL}	6.0	-	150	μ A	V _I =0V 【Note 6-7】
Input current (High)		I _{IH}	-	-	2.0	μ A	V _I =VCC 【Note 6-7】

【Note 6-1】

On-off conditions for supply voltage

- 0 < t1 ≤ 10ms
- 0 < t2 ≤ 10ms
- 0 < t3 ≤ 1s
- t4 ≥ 1s

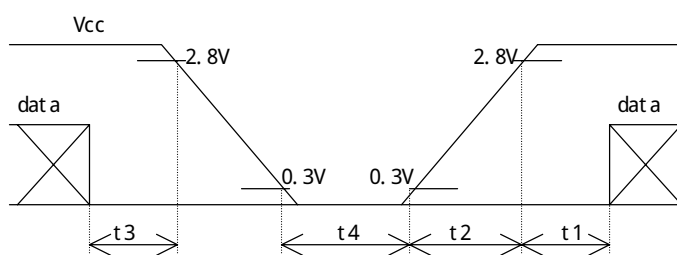

Vcc-dip conditions

- 1) 2.8V ≤ Vcc < 3.0V
- td ≤ 10ms
- 2) Vcc < 2.8V

Vcc-dip conditions should also follow the on-off conditions.

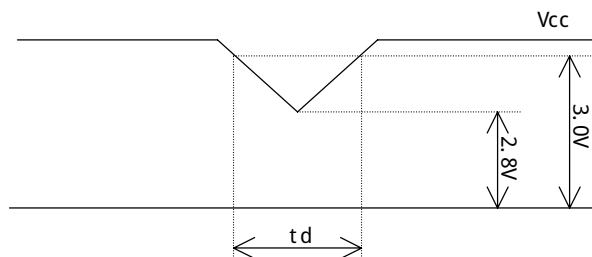

【Note 6-2】

Typical current situation: Black (GS0) pattern

Timing: Typical

VCC= +3.3 V

Black (GS0)

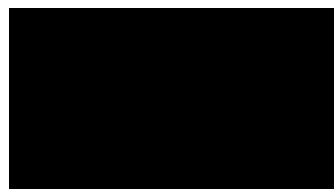

【Note 6-3】 Maximum current situation: Vertical stripe pattern alternating 21 gray scale (GS21) with 42 gray scale (GS42) every 1 dot.

Timing: Typical

VCC= +3.3 V

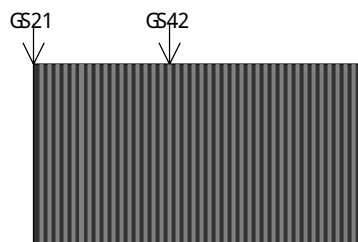

【Note 6-4】 CK,R0 ~ R5,G0 ~ G5,B0 ~ B5,Hsync,Vsync,ENAB,HVR

【Note 6-5】 CK,R0 ~ R5,G0 ~ G5,B0 ~ B5,Hsync,Vsync

【Note 6-6】 ENAB

【Note 6-7】 HVR

6-2) Backlight driving section

The backlight system is an edge-lighting type with single CCFT (Cold Cathode Fluorescent Tube). The characteristics of Lamp are shown in the following table.

Table 6-2

Parameter	Symbol	MIN	TYP	MAX	Unit	Remarks
lamp voltage	V L 7	470	530	590	Vrms	I L = 5.5mArms
lamp current	I L	5.0	5.5	6.0	mArms	ordinary state
	I L B	-	-	9.0	mArms	PWM dimming state 【Note 6-8】
lamp frequency	f L	30	-	60	kHz	
kick-off voltage	V S	-	-	1650	Vrms	Ta=+25°C
		-	-	1700	Vrms	Ta=-30°C

Inverter : HIU-288 [Harison electric co.,ltd] (Output capacitor:22pF,frequency:49kHz)

【Note 6-8】 available area

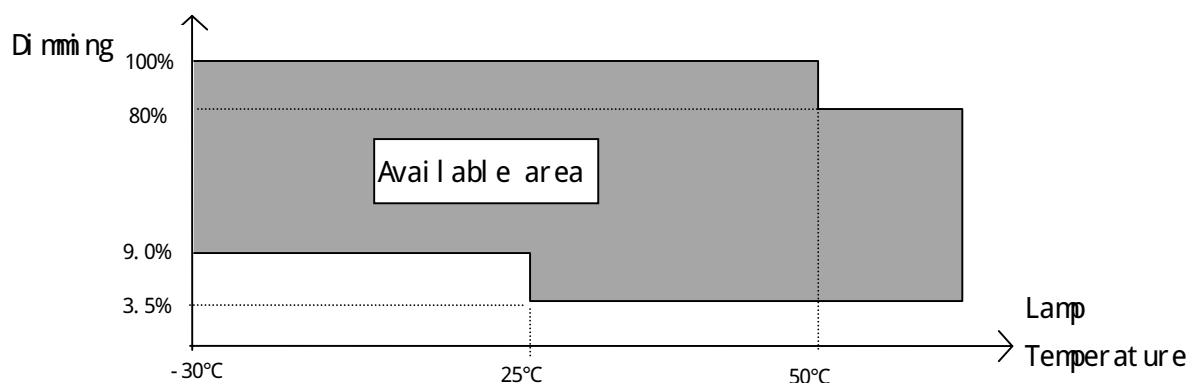

* Please turn on the lamp with symmetrical (negative and positive)voltage and current wave form. Don't use the unsymmetrical voltage and current wave which have spike wave.

(7) Timing Characteristics of input signals

Timing diagrams of input signal are shown in Fig.3-A, Fig.3-B.

7-1) Timing characteristics

Table 7-1

Parameter	Symbol	MIN	TYP	MAX	Unit	Remarks
Clock	frequency	1/Tc	4.5	6.3	6.8	MHz
	High time	Tch	50	-	-	ns
	Low time	Tcl	50	-	-	ns
Data	Setup time	Tds	50	-	-	ns
	Hold time	Tdh	50	-	-	ns
Hsync-Clock phase difference	THc	50	-	120	ns	
Hsync-Vsync phase difference	TVh	0	-	TH-10	μ s	

Note) In case of lower frequency, the deterioration of display quality, flicker etc., may be occurred.

7-2) Horizontal display position

①In case ENAB is active

The horizontal display position is determined by ENAB signal and the input data corresponding to the rising edge of ENAB signal is displayed at the left end of the active area. (shown in Fig.3-A.)

Parameter		symbol	Min.	Typ.	Max.	Unit	Remark
Horizontal sync. signal	Cycle	TH	50	63.5	80	μ s	
			THe+308	400	440	clock	
	Pulse width	THp	4	12	30	clock	
Enable signal	Setup time	Tes	50	-	Tc- 10	ns	
	Pulse width	Tep		320		clock	
Hsync-Enable signal phase difference		THe	14	-	72	clock	
Horizontal display period		THd	320	320	320	clock	

②In case ENAB is "Low". (shown in Fig.3-B)

Parameter		symbol	Min.	Typ.	Max.	Unit	Remark
Horizontal sync. signal	Cycle	TH	56	63.5	80	μ s	
			380	400	440	clock	
	Pulse width	THp	4	12	30	clock	
Hsync-data signal phase difference		THe	72	72	72	clock	
Horizontal display period		THd	320	320	320	clock	

7-3) Vertical display position

Parameter		Symbol	MIN	TYP	MAX	Unit	Remarks
Vertical sync. signal	Cycle	TV	246	263	330	line	
	Pulse width	TVp	1	-	-	line	
Vertical display start position		TVs	6	6	6	line	
Vertical display period		TVd	240	240	240	line	

ENAB signal has no relation to the vertical display position.

7-4) Input Data Signals and Display Position on the screen

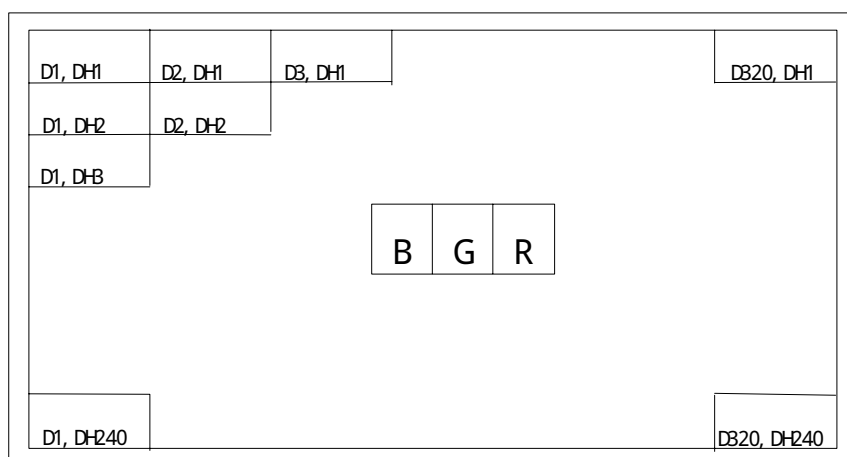

Display position of input data (H,V)

(8) Input Signals, Basic Display Color and Gray Scale of Each Color

	Colors &	Data signal																		
	Gray scale	Gray Scale	R0	R1	R2	R3	R4	R5	G0	G1	G2	G3	G4	G5	B0	B1	B2	B3	B4	B5
Basic color	Black	-	0	0	0	0	0	0	0	0	0	0	0	0	0	0	0	0	0	0
	Blue	-	0	0	0	0	0	0	0	0	0	0	0	0	1	1	1	1	1	1
	Green	-	0	0	0	0	0	0	1	1	1	1	1	1	0	0	0	0	0	0
	Cyan	-	0	0	0	0	0	0	1	1	1	1	1	1	1	1	1	1	1	1
	Red	-	1	1	1	1	1	1	0	0	0	0	0	0	0	0	0	0	0	0
	Magenta	-	1	1	1	1	1	1	0	0	0	0	0	0	1	1	1	1	1	1
	Yellow	-	1	1	1	1	1	1	1	1	1	1	1	1	0	0	0	0	0	0
	White	-	1	1	1	1	1	1	1	1	1	1	1	1	1	1	1	1	1	1
Gray Scale of red	Black	GS0	0	0	0	0	0	0	0	0	0	0	0	0	0	0	0	0	0	0
	↑	GS1	1	0	0	0	0	0	0	0	0	0	0	0	0	0	0	0	0	0
	Darker	GS2	0	1	0	0	0	0	0	0	0	0	0	0	0	0	0	0	0	0
	↑	↓				↓					↓					↓				
	↓	↓				↓					↓					↓				
	Brighter	GS61	1	0	1	1	1	1	0	0	0	0	0	0	0	0	0	0	0	0
	↓	GS62	0	1	1	1	1	1	0	0	0	0	0	0	0	0	0	0	0	0
	Red	GS63	1	1	1	1	1	1	0	0	0	0	0	0	0	0	0	0	0	0
Gray Scale of green	Black	GS0	0	0	0	0	0	0	0	0	0	0	0	0	0	0	0	0	0	0
	↑	GS1	0	0	0	0	0	0	1	0	0	0	0	0	0	0	0	0	0	0
	Darker	GS2	0	0	0	0	0	0	0	1	0	0	0	0	0	0	0	0	0	0
	↑	↓				↓					↓					↓				
	↓	↓				↓					↓					↓				
	Brighter	GS61	0	0	0	0	0	0	1	0	1	1	1	1	0	0	0	0	0	0
	↓	GS62	0	0	0	0	0	0	0	1	1	1	1	1	0	0	0	0	0	0
	Green	GS63	0	0	0	0	0	0	1	1	1	1	1	1	0	0	0	0	0	0
Gray Scale of blue	Black	GS0	0	0	0	0	0	0	0	0	0	0	0	0	0	0	0	0	0	0
	↑	GS1	0	0	0	0	0	0	0	0	0	0	0	0	1	0	0	0	0	0
	Darker	GS2	0	0	0	0	0	0	0	0	0	0	0	0	0	1	0	0	0	0
	↑	↓				↓					↓					↓				
	↓	↓				↓					↓					↓				
	Brighter	GS61	0	0	0	0	0	0	0	0	0	0	0	0	1	0	1	1	1	1
	↓	GS62	0	0	0	0	0	0	0	0	0	0	0	0	0	1	1	1	1	1
	Blue	GS63	0	0	0	0	0	0	0	0	0	0	0	0	1	1	1	1	1	1

0 :Low level voltage 1 :High level voltage

Each basic color can be displayed in 64 gray scales from 6 bit data signals. According to the combination of total 18 bit data signals, the 262,144-color display can be achieved on the screen.

(9) Optical characteristics

Table 9-1

Ta=+25°C, VCC=+3.3V

Parameter	Symbol	Condition	Min	Typ	Max	Unit	Remarks	
Viewing angle range	$\Delta \theta_{11}$	CR \geq 5	60	65	-	° (degree)	【Note 9-1,4】	
	$\Delta \theta_{12}$		35	40	-	° (degree)		
	$\Delta \theta_2$		60	65	-	° (degree)		
Contrast ratio	CRmax	Optimal	100	-	-		【Note 9-2,4】	
Response time	Rise	$\theta = 0^\circ$	-	30	60	ms	【Note 9-3,4】	
	Fall		-	50	100	ms		
Luminance	Y	IL=5.5mA rms	350	450	-	cd/m ²	【Note 9-5】	
White chromaticity	x	IL=5.5mA rms	0.263	0.313	0.363			
	y	IL=5.5mA rms	0.279	0.329	0.379			
lamp life time	+25°C	-	continuation	20,000	-	-	hour	【Note 9-6】
	-30°C	-	intermission	2,000	-	-	time	【Note 9-7】

DC/AC inverter for external connection shown in following.

Inverter : HIU-288 [Harison electric co.,ltd] (Output capacitor:22pF,frequency:49kHz)

measuring after operating during 30minutes.

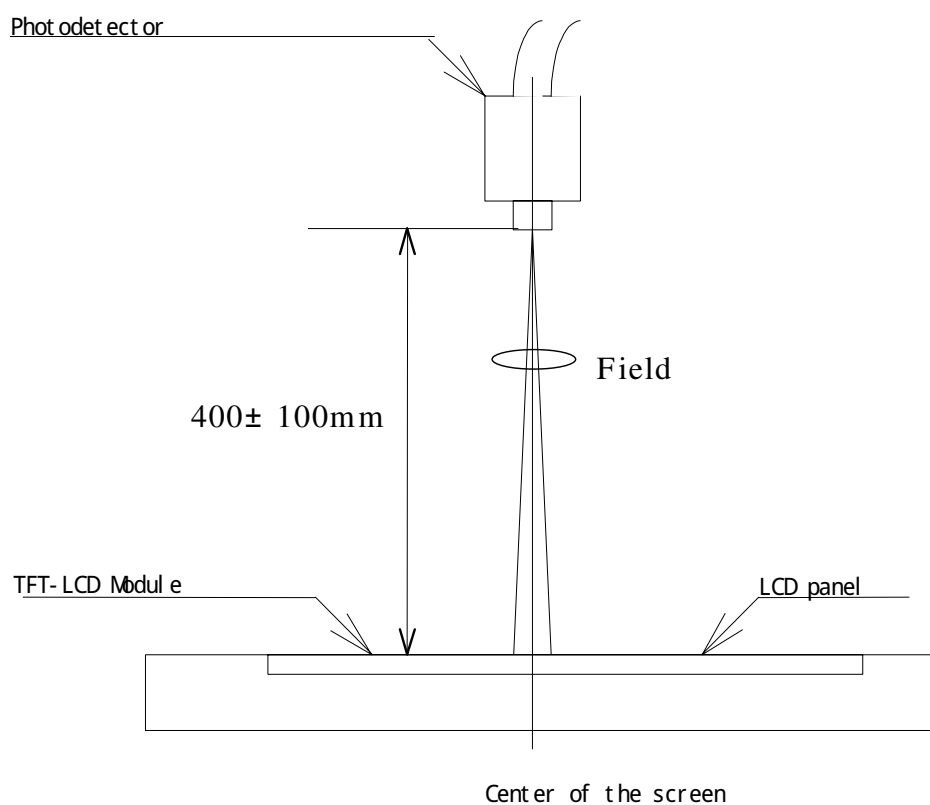
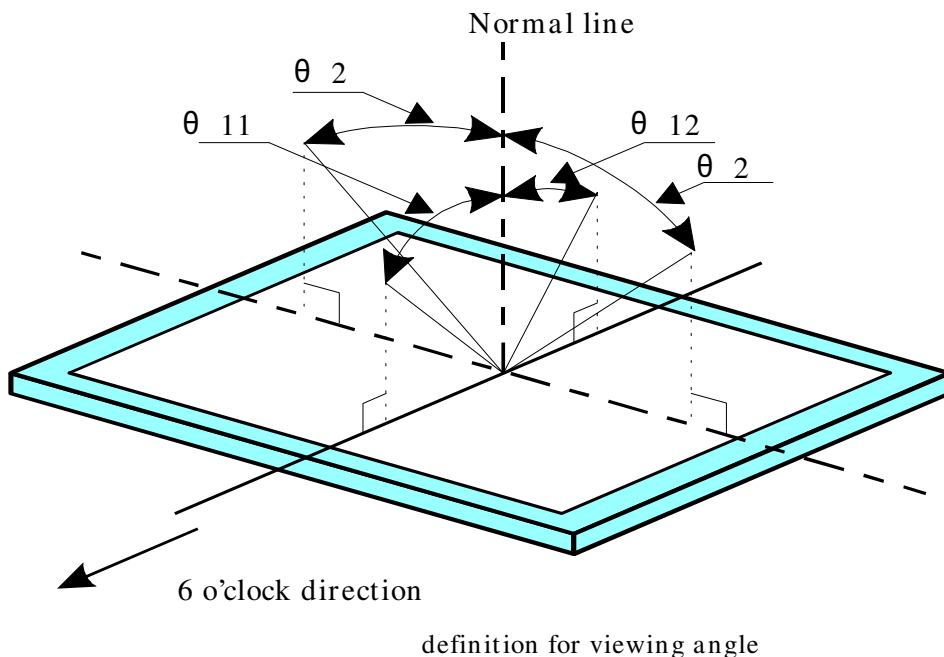

Fig.9-1 Optical characteristics measurement method

【Note 9-1】 Viewing angle range is defined as follows.



【Note 9-2】 Contrast ratio is defined as follows:

$$\text{Contrast ratio(CR)} = \frac{\text{Photo detector output with LCD being "white"}}{\text{Photo detector output with LCD being "black"}}$$

【Note 9-3】 Response time is obtained by measuring the transition time of photo detector output, when input signals are applied so as to make the area "black" to and from "white".

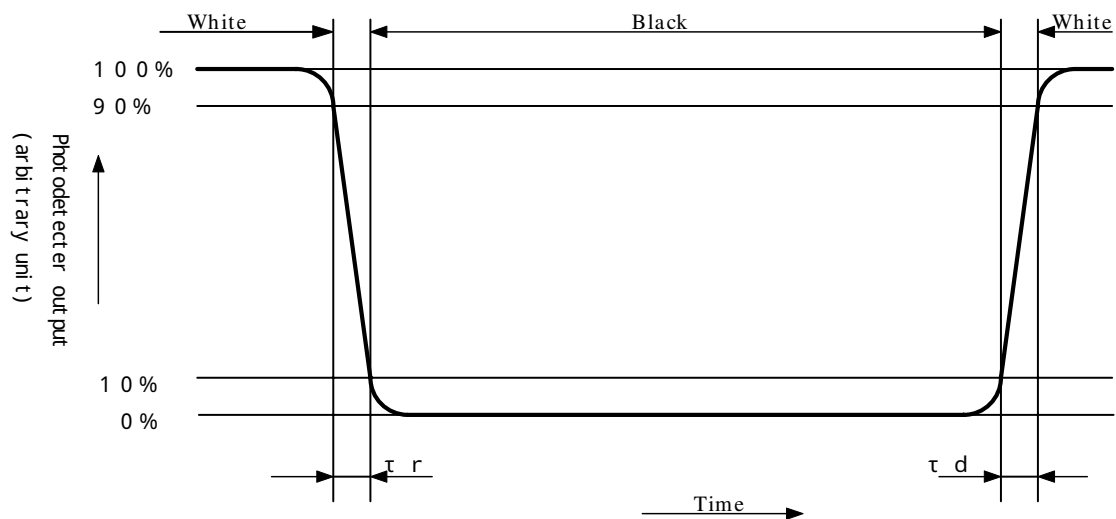

【Note 9-4】 Measured on the center area of the panel at a viewing cone 2° (= Filed) by TOPCON luminance meter BM-5A or ELDIM luminance meter EZ Contrast. (After 30 minutes operation)

DC/AC inverter driving frequency:(49 kHz)

【Note 9-5】 Measured on the center area of the panel at a viewing cone 1° (= Filed) by TOPCON luminance meter BM-7.(After 30 minutes operation)

DC/AC inverter driving frequency:(49 kHz)

【Note 9-6】 Lamp life time is defined as the time when either or occurs in the continuous operation under the condition of lamp current $I_L=5.5\text{mA rms}$

Brightness not to become under 50% of the original value.

【Note 9-7】 The intermittent cycles is defined as a time when brightness not to become under 50% of the original value under the condition of following cycle.

Ambient temperature:-30°C

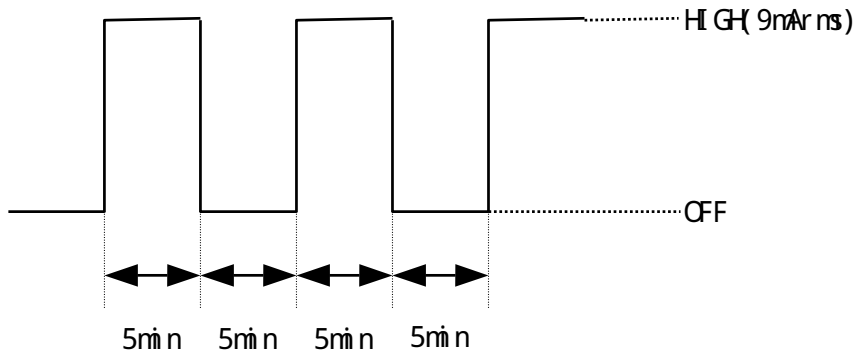

(10) Mechanical characteristics

10-1) External appearance

Do not exist extreme defects. (See Fig. 1)

10-2) Panel toughness

The panel shall not be broken ,when 19N is pressed on the center of the panel by a smooth sphere having 15 mm diameter.

Caution: In spite of very soft toughness, if, in the long-term, add pressure on the active area, it is possible to occur the functional damage.

10-3) Input/output connector performance

I/O connector of backlight driving circuit 【JST】

Lump connector

Symbol	Used Connector	Corresponding connector
CN A, B	BHR-02(8.0)VS-1N	SM02(8.0)B-BHS-1N(assembled on PWB)
		SM02(8.0)B-BHS-TB(assembled on PWB)
		BHMR-03V (interconnector)

(11) Display quality

The display quality of the color TFT-LCD module shall be in compliance with the Incoming Inspection Standards for TFT-LCD.

(12) Handling instructions

12-1) Mounting of module

The TFT-LCD module is designed to be mounted on equipment using the mounting tabs in the four corners of the module at the rear side.

On mounting the module, as the M2.6 tapping screw fastening torque is 0.3 through 0.5N·m is recommended, be sure to fix the module on the same plane, taking care not to wrap or twist the module.

Don't reach the pressure of touch-switches of the set side to a module directly, because images may be disturbed.

Please power off the module when you connect the input/output connector.

Please connect the metallic shielding cases of the module and the ground pattern of the inverter circuit surely. If that connection is not perfect, there may be a possibility that the following problems happen.

- a). The noise from the backlight unit will increase.
- b). The output from inverter circuit will be unstable. Then, there may be a possibility that some problems happen.
- c). In some cases, a part of module will heat.

12-2) Precautions in mounting

Polarizer which is made of soft material and susceptible to flaw must be handled carefully.

Protective film (Laminator) is applied on the surface to protect it against scratches and dirties. It is recommended to peel off the laminator immediately before the use, taking care of static electricity.

Precautions in peeling off the laminator

A) Working environment

When the laminator is peeled off, static electricity may cause dust to stick to the polarizer surface. To avoid this, the following working environment is desirable.

- a) Floor: Conductive treatment of $1M\Omega$ or more on the tile
(conductive mat or conductive paint on the tile)
- b) Clean room free from dust and with an adhesive mat on the doorway
- c) Advisable humidity: 50% ~ 70% Advisable temperature: 15°C ~ 27°C
- d) Workers shall wear conductive shoes, conductive work clothes, conductive gloves and an earth band.

B) Working procedures

- a) Direct the wind of discharging blower somewhat downward to ensure that module is blown sufficiently. Keep the distance between module and discharging blower within 20 cm.
- b) Attach adhesive tape to the laminator part near discharging blower so as to protect polarizer against flaw.
- c) Peel off laminator, pulling adhesive tape slowly to your side taking 5 or more second.
- d) On peeling off the laminator, pass the module to the next work process to prevent the module to get dust.
- e) Method of removing dust from polarizer
 - Blow off dust with N₂ blower for which static electricity preventive measure has been taken.
 - Since polarizer is vulnerable, wiping should be avoided.

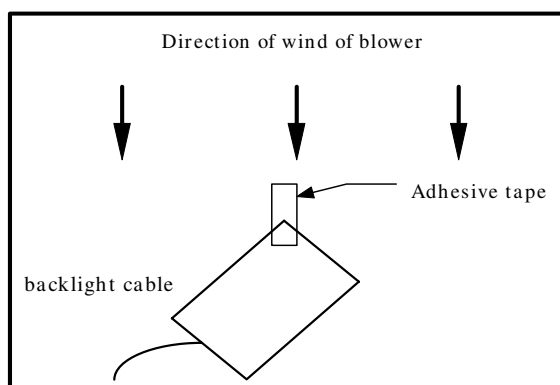
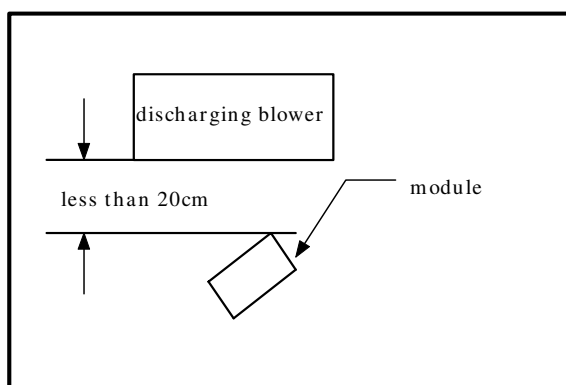

But when the panel has stain or grease, we recommend to use adhesive tape to softly remove them from the panel.

When metal part of the TFT-LCD module (shielding lid and rear case) is soiled, wipe it with soft dry cloth. For stubborn dirties, wipe the part, breathing on it. Wipe off water drop or finger grease immediately. Long contact with water may cause discoloration or spots. TFT-LCD module uses glass which breaks or cracks easily if dropped or bumped on hard surface. Handle with care. Since CMOS LSI is used in this module, take care of static electricity and earth your body when handling.

12-3) Precautions in adjusting module

Adjusting volumes on the rear face of the module have been set optimally before shipment. Therefore, do not change any adjusted values. If adjusted values are changed, the specifications described here may not be satisfied.

12-4) Caution of product design

The LCD module shall be protected against water salt-water by the waterproof cover. Please take measures to interferential radiation from module, to do not interfere surrounding appliances.

12-5) Others

Do not expose the module to direct sunlight or intensive ultraviolet rays for many hours; liquid crystal is deteriorated by ultraviolet rays. Store the module at a temperature near the room temperature. At lower than the rated storage temperature, liquid crystal solidifies, causing the panel to be damaged. At higher than the rated storage temperature, liquid crystal turns into isotropic liquid and may not recover. The voltage of beginning electric discharge may over the normal voltage because of leakage current from approach conductor by to draw lump read lead line around. If LCD panel breaks, there may be a possibility that the liquid crystal escapes from the panel. Since the liquid crystal is injurious, do not put it into the eyes or mouth. When liquid crystal sticks to hands, feet or clothes, wash it out immediately with soap. Observe all other precautionary requirements in handling general electronic components.

(13) Packing form (shown in Fig.5.)

Piling number of cartons	: MAX 10
Package quantity in one carton	: 50 pcs
Carton size	: 503 (W)× 166 (H)× 338 (D) mm
Total mass of one carton filled with full modules	: 7.5kg

Conditions for storage.

Environment

- | | |
|-------------------------|---|
| ①Temperature | : 0 ~ 40°C |
| ②Humidity | : 60%RH or less (at 40°C)
No dew condensation at low temperature and high humidity. |
| ③Atmosphere | : Harmful gas, such as acid or alkali which bites electronic components and/or wires, must not be detected. |
| ④Period | : about 3 months |
| ⑤Opening of the package | : In order to prevent the LCD module from breakdown by electrostatic charges, please control the room humidity over 50%RH and open the package taking sufficient countermeasures against electrostatic charges, such as earth, etc. |

(14) Reliability test

Reliability test conditions for the TFT-LCD module are shown in Table 14.

(15) Others

Adjusting volume have been set optimally before shipment, so do not change any adjusted value.
 If adjusted value is changed, the specification may not be satisfied.
 Disassembling the module can cause permanent damage and should be strictly avoided.
 Please be careful since image retention may occur when a fixed pattern is displayed for a long time.

15-1) Indication of lot number

① Attached location of the label : See Fig. 1

② Indicated contents of the

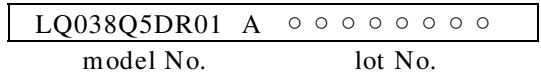

contents of lot No. the 1st figure .. production year (ex. 2005 : 5)
 the 2nd figure .. production month 1,2,3,.. .. ,9,X,Y,Z
 the 3rd ~ 8th figure .. serial No. 000001 ~
 the 9th figure .. revision marks A,B,C..

Reliability Test Conditions for TFT-LCD Module

Table 14

Remark) Temperature condition is based on operating temperature conditions on (5)-Table 5-1.

No.	Test items	Test conditions
1	High temperature storage test	Ta= +95°C 240h
2	Low temperature storage test	Ta=- 40°C 240h
3	High temperature and high humidity operating test	Tp= +60°C , 95%RH 240h
4	High temperature operating test	Tp= +85°C 240h
5	Low temperature operating test	Ta= - 30°C 240h
6	Electro static discharge test	± 200V · 200pF(0Ω) 1 time for each terminals
7	Shock test	980m/s ² · 6ms, ± X ; ± Y ; ± Z 3 times for each direction (JIS C0041, A-7 Condition C)
8	Vibration test	Frequency range : 8 ~ 33.3Hz Stroke : 1.3mm Sweep : 33.3Hz ~ 400Hz Acceleration : 28.4m/s ² Cycle : 15 minutes X,Z 2 hours for each directions, 4 hours for Y direction (total 8 hours) 【caution】(JIS D1601)
9	Heat shock test	Ta= -40°C ~ +95°C / 200 cycles (0.5h) (0.5h)

【Note】 Ta= Ambient temperature, Tp= Panel temperature

【Check items】 In the standard condition, there shall be no practical problems that may affect the display function.

【caution】 X,Y,Z directions are shown as follows:

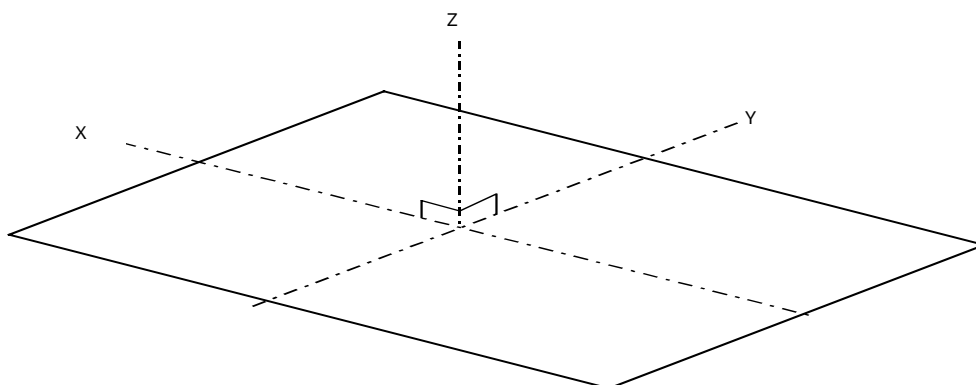

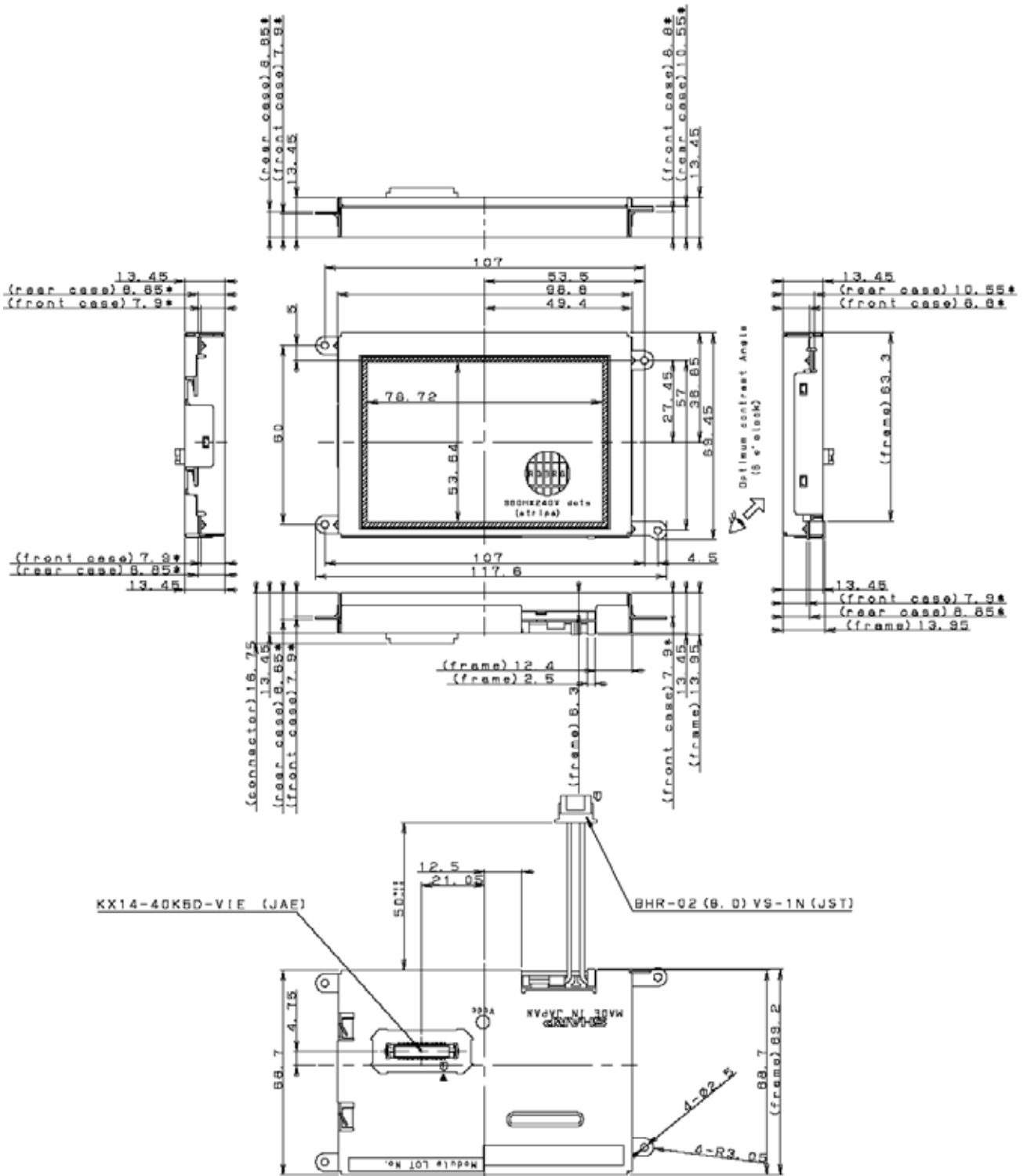

note1) General tolerance is ± 0.3
 note2) Unit is mm
 note3) The dimension marked * shows the base of counting tab

OUTLINE DIMENSIONS of LQ038Q5DR01

2005. 8. 9
 No: LCM-00040A

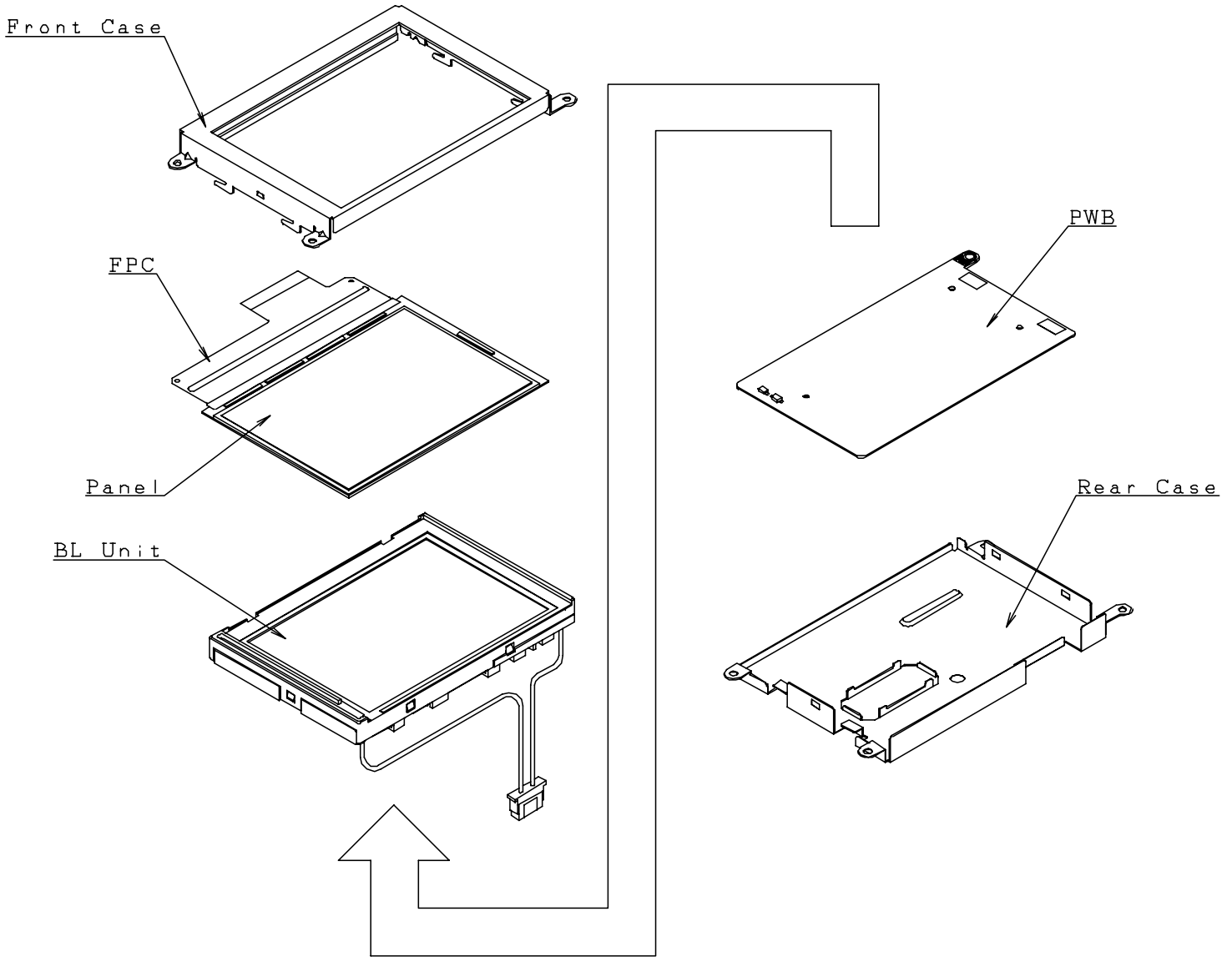

Fig.2. Structure of the module

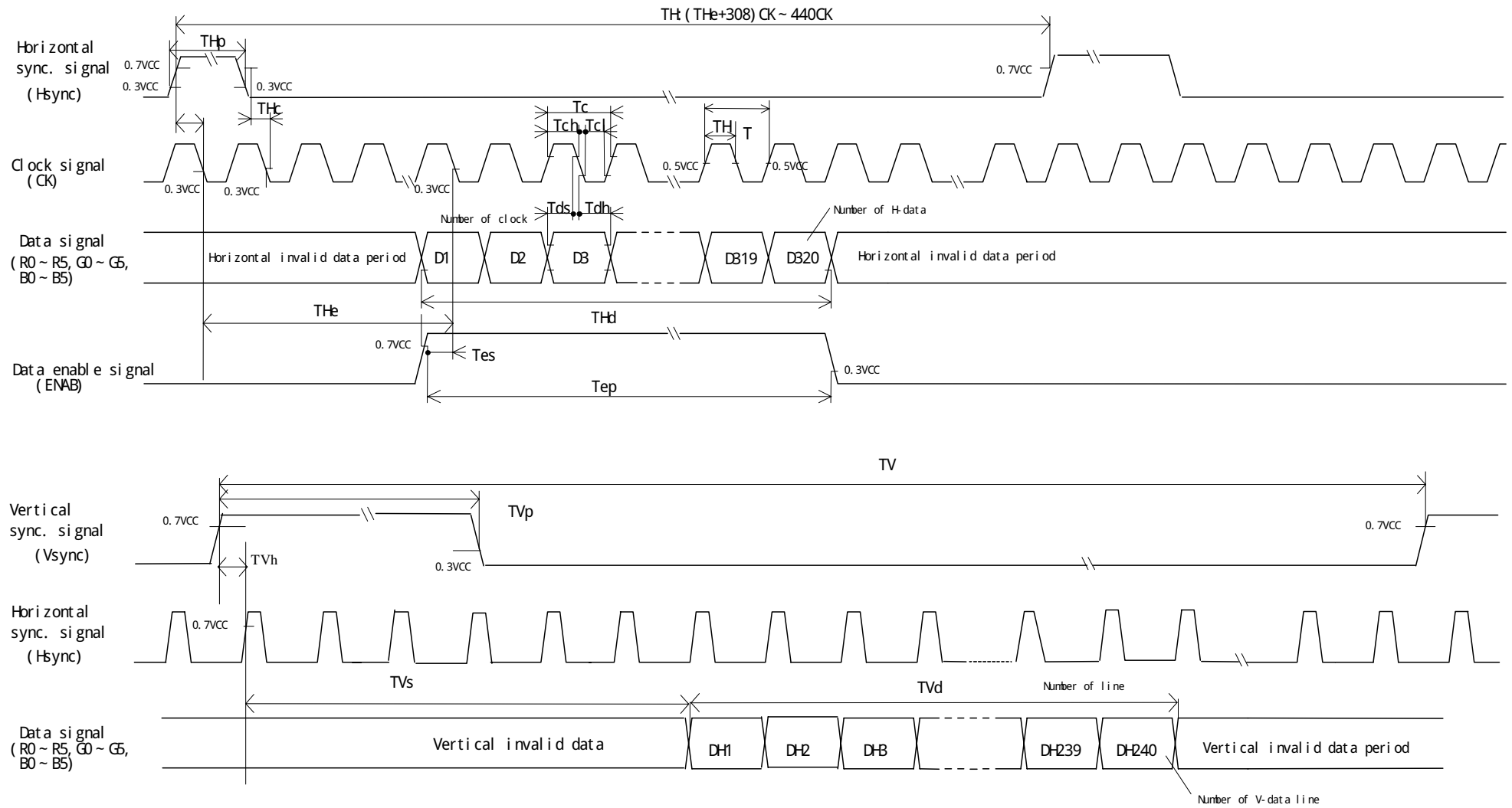

Fig.3-A Input signal waveform

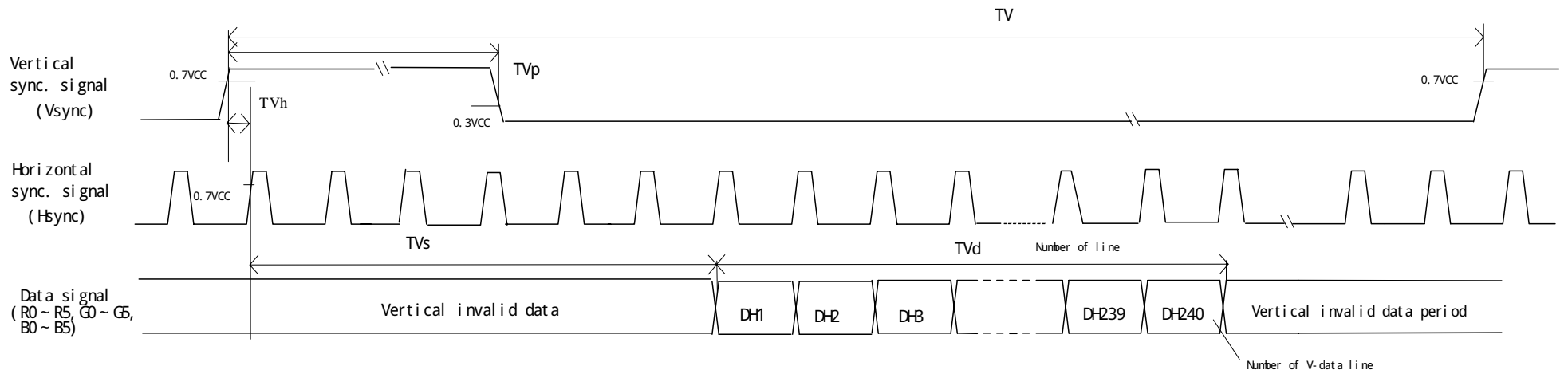
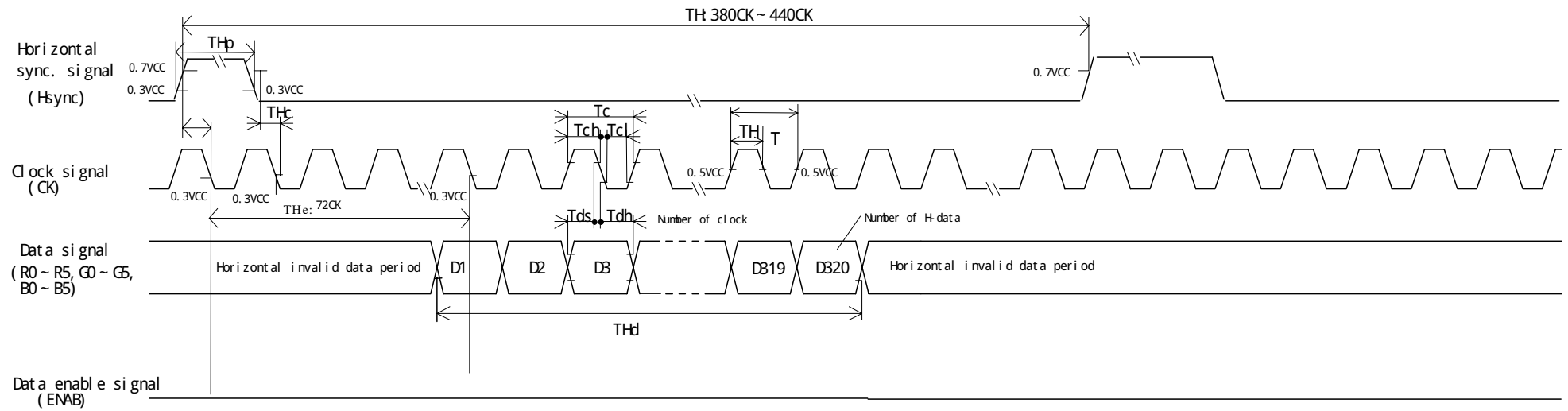

Fig.3-B Input signal waveform

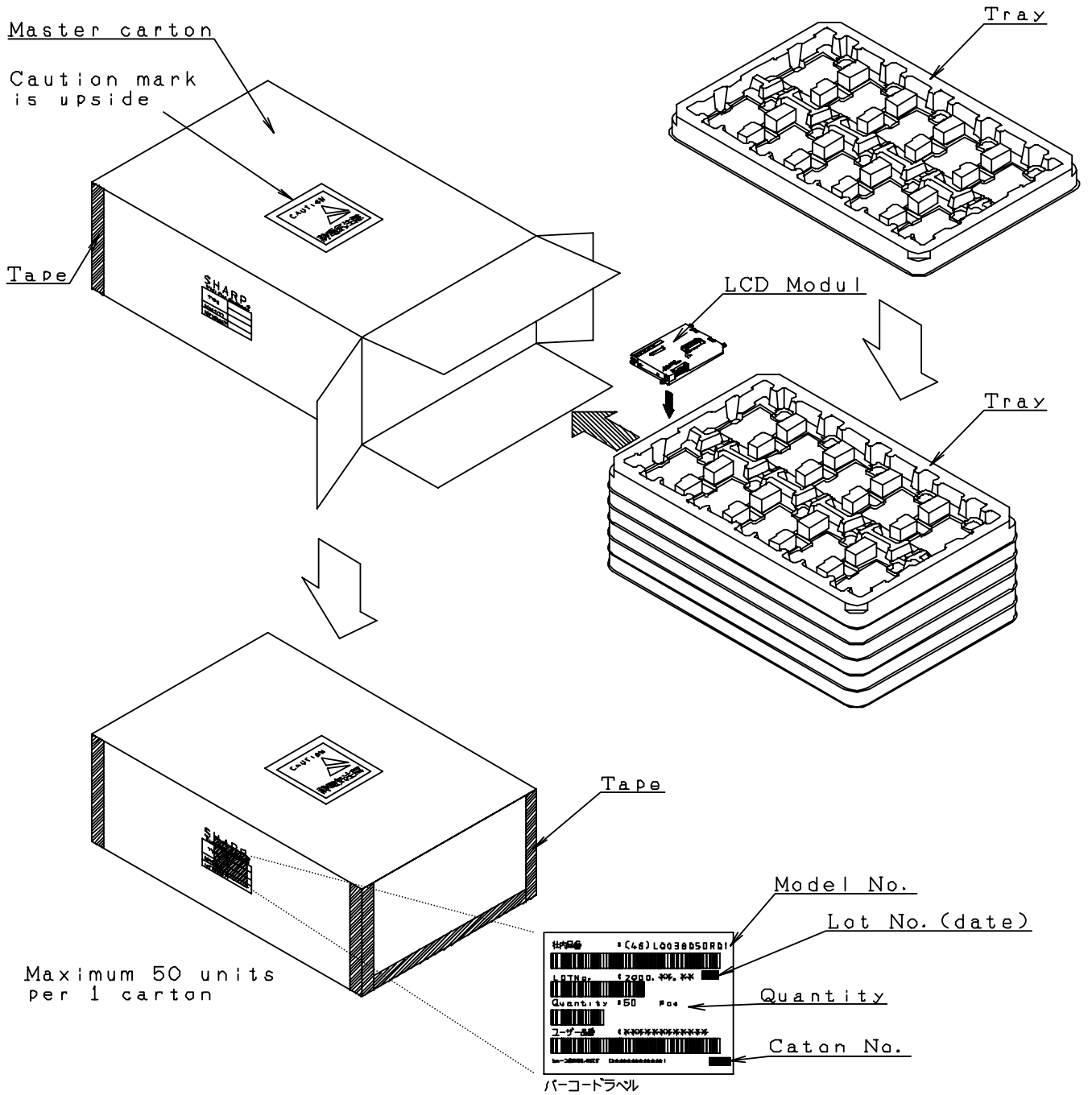

Fig.4.Packing form

NOTICE

This publication is the proprietary of SHARP and is copyrighted, with all rights reserved. Under the copyright laws, no part of this publication may be reproduced or transmitted in any form or by any means, electronic or mechanical for any purpose, in whole or in part, without the express written permission of SHARP. Express written permission is also required before any use of this publication may be made by a third party.

The application circuit examples in this publication are provided to explain the representative applications of SHARP's devices and are not intended to guarantee any circuit design or permit any industrial property right or other rights to be executed. SHARP takes no responsibility for any problems related to any industrial property right or a third party resulting from the use of SHARP's devices, except for those resulting directly from device manufacturing processes.

In the absence of confirmation by device specification sheets, SHARP takes no responsibility for any defects that occur in equipment using any of SHARP's devices, shown in catalogs, data books, etc. Contact SHARP in order to obtain the latest device specification sheets before using any SHARP's device.

SHARP reserves the right to make changes in the specifications, characteristics, data, materials, structures and other contents described herein at any time without notice in order to improve design or reliability. Contact SHARP in order to obtain the latest specification sheets before using any SHARP's device. Manufacturing locations are also subject to change without notice.

Observe the following points when using any device in this publication. SHARP takes no responsibility for damage caused by improper use *of the devices*.

The appropriate design measures should be taken to ensure reliability and safety when SHARP's devices are used for equipment such as:

- Transportation control and safety equipment (i.e., aircraft, trains, automobiles, etc.)
- Traffic signals
- Alarm equipment
- Gas leakage sensor breakers
- Various safety devices etc.

SHARP's devices shall not be used for equipment that requires extremely high level of reliability, such as:

- Military and space applications
- Medical equipment for life support
- Nuclear power control equipment

Contact a SHARP representative, in advance, when intending to use SHARP's devices for any "specific" applications other than those recommended by SHARP.

Contact and consult with a SHARP representative if there are any questions about the contents of this publication.

SPECIFICATIONS ARE SUBJECT TO CHANGE WITHOUT NOTICE.

Suggested applications (if any) are for standard use; See Important Restrictions for limitations on special applications. See Limited Warranty for SHARP's product warranty. The Limited Warranty is in lieu, and exclusive of, all other warranties, express or implied. ALL EXPRESS AND IMPLIED WARRANTIES, INCLUDING THE WARRANTIES OF MERCHANTABILITY, FITNESS FOR USE AND FITNESS FOR A PARTICULAR PURPOSE, ARE SPECIFICALLY EXCLUDED. In no event will SHARP be liable, or in any way responsible, for any incidental or consequential economic or property damage.

SHARP®

NORTH AMERICA

SHARP Microelectronics of the Americas
5700 NW Pacific Rim Blvd.
Camas, WA 98607, U.S.A.
Phone: (1) 360-834-2500
Fax: (1) 360-834-8903
Fast Info: (1) 800-833-9437
www.sharpsma.com

EUROPE

SHARP Microelectronics Europe
Division of Sharp Electronics (Europe) GmbH
Sonninstrasse 3
20097 Hamburg, Germany
Phone: (49) 40-2376-2286
Fax: (49) 40-2376-2232
www.sharpsme.com

JAPAN

SHARP Corporation
Electronic Components & Devices
22-22 Nagaike-cho, Abeno-Ku
Osaka 545-8522, Japan
Phone: (81) 6-6621-1221
Fax: (81) 6117-725300/6117-725301
www.sharp-world.com

TAIWAN

SHARP Electronic Components
(Taiwan) Corporation
8F-A, No. 16, Sec. 4, Nanking E. Rd.
Taipei, Taiwan, Republic of China
Phone: (886) 2-2577-7341
Fax: (886) 2-2577-7326/2-2577-7328

SINGAPORE

SHARP Electronics (Singapore) PTE., Ltd.
438A, Alexandra Road, #05-01/02
Alexandra Technopark,
Singapore 119967
Phone: (65) 271-3566
Fax: (65) 271-3855

KOREA

SHARP Electronic Components
(Korea) Corporation
RM 501 Geosung B/D, 541
Dohwa-dong, Mapo-ku
Seoul 121-701, Korea
Phone: (82) 2-711-5813 ~ 8
Fax: (82) 2-711-5819

CHINA

SHARP Microelectronics of China
(Shanghai) Co., Ltd.
28 Xin Jin Qiao Road King Tower 16F
Pudong Shanghai, 201206 P.R. China
Phone: (86) 21-5854-7710/21-5834-6056
Fax: (86) 21-5854-4340/21-5834-6057

Head Office:

No. 360, Bashen Road,
Xin Development Bldg. 22
Waigaoqiao Free Trade Zone Shanghai
200131 P.R. China
Email: smc@china.global.sharp.co.jp

HONG KONG

SHARP-ROXY (Hong Kong) Ltd.
3rd Business Division,
17/F, Admiralty Centre, Tower 1
18 Harcourt Road, Hong Kong
Phone: (852) 28229311
Fax: (852) 28660779
www.sharp.com.hk

Shenzhen Representative Office:

Room 13B1, Tower C,
Electronics Science & Technology Building
Shen Nan Zhong Road
Shenzhen, P.R. China
Phone: (86) 755-3273731
Fax: (86) 755-3273735