



# FSA3341 — High-Speed 4:1 USB2.0 / MHL™ Switch

## Features

- Low On Capacitance: 4.2 pF / 5 pF MHL / USB (Typical)
- Low Power Consumption: 30  $\mu$ A Maximum
- Supports MHL Rev. 2.0
- Three USB2.0 Paths
- MHL Data Rate: 4.0 Gbps
- Packaged in 16-Lead UMLP (1.8 x 2.6 mm)
- Over-Voltage Tolerance on All USB Ports: Up to 5.25 V without External Components

## Applications

- Cell Phones and Digital Cameras

## Description

The FSA3341 is a bi-directional, low-power, high-speed, 4:1, USB2.0 and MHL™ switch. Configured as a Double-Pole, Four-Throw (DP4T) switch; it is optimized for switching between high- or full-speed USB and Mobile High-Definition Link sources (MHL Rev. 2.0 specification). In addition, the USB2.0 paths can be used as UART paths.

The FSA3341 contains circuitry on the switch I/O pins that allows the device to withstand an over-voltage condition for applications where the  $V_{CC}$  supply is powered off ( $V_{CC} = 0$  V). This switch is designed to minimize current consumption even when the control voltage applied to the control pins is lower than the supply voltage ( $V_{CC}$ ). This is especially valuable in mobile applications, such as cell phones, allowing direct interface with the general-purpose I/Os of the baseband processor. Other applications include switch sharing in portable cell phones, digital cameras, and notebook computers.

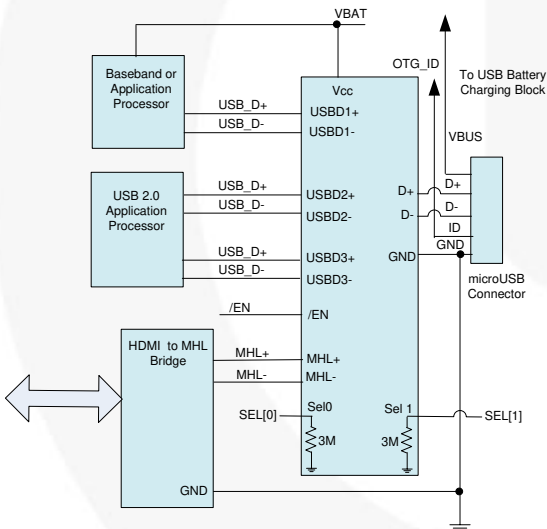


Figure 1. Typical Application

## Ordering Information

Part Number	Top Mark	Operating Temperature Range	Package
FSA3341UMX	LY	-40 to +85°C	16-Lead, Ultrathin Molded Leadless Package (UMLP), 1.8 mm x 2.6 mm

All trademarks are the property of their respective owners.

## Pin Configuration

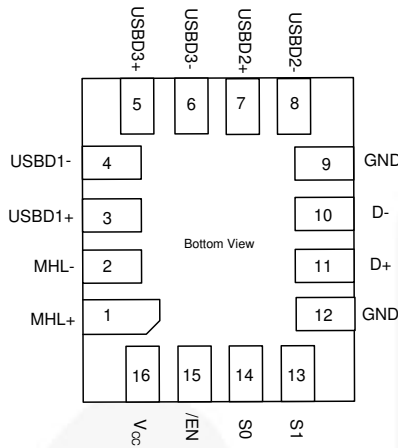


Figure 2. Pin Assignments

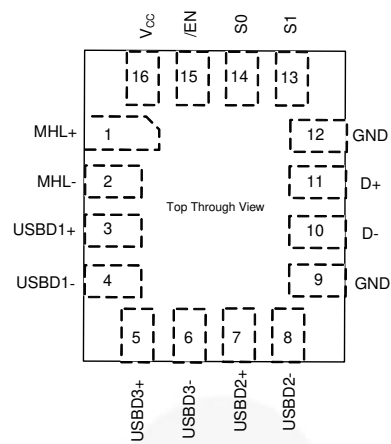


Figure 3. Top Through View

## Pin Definitions

Pin#	Name	Description
1	MHL+	MHL Differential Data (Positive)
2	MHL-	MHL Differential Data (Negative)
3	USB1+	USB Differential Data (Positive); also can be used as additional UART
4	USB1-	USB Differential Data (Negative); also can be used as additional UART
5	USB3+	USB Differential Data (Positive); also can be used as additional UART
6	USB3-	USB Differential Data (Negative); also can be used as additional UART
7	USB2+	USB Differential Data (Positive); can be used as a UART port (see Figure 1)
8	USB2-	USB Differential Data (Negative); can be used as a UART port (see Figure 1)
9	GND	Ground
10	D-	USB Differential Data (Negative), Common Port
11	D+	USB Differential Data (Positive), Common Port
12	GND	Ground
13	S1	Data Switch Select (see Table 1)
14	S0	Data Switch Select (see Table 1)
15	/EN	Enable Pin - Active LOW
16	V <sub>CC</sub>	Device Power from System (Typically V <sub>BAT</sub> )

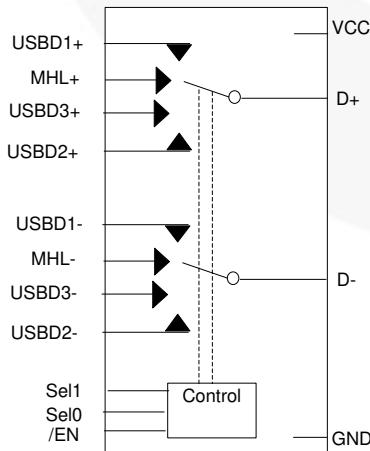


Figure 4. Analog Symbol

Table 1. Data Switch Select Truth Table

SEL1 <sup>(1)</sup>	SEL0 <sup>(1)</sup>	/EN <sup>(1)</sup>	Function
0	0	0	D+/D- connected to USB1+/ USB1- (or UART) path
0	1	0	D+/D- connected to USB2+/ USB2- (or UART) path
1	0	0	D+/D- connected to MHL+/ MHL- path
1	1	0	D+/D- connected to USB3+/ USB3- (or UART) path
X	X	1	D+/D- high impedance

**Note:**

- Control inputs should never be left floating or unconnected. To guarantee default switch closure to the USB position, the SEL[0:1] pins are tied to GND with internal weak pull-down resistors (3 MΩ) to minimize static current draw.

## Absolute Maximum Ratings

Stresses exceeding the absolute maximum ratings may damage the device. The device may not function or be operable above the recommended operating conditions and stressing the parts to these levels is not recommended. In addition, extended exposure to stresses above the recommended operating conditions may affect device reliability. The absolute maximum ratings are stress ratings only.

Symbol	Parameter	Min.	Max.	Unit
V <sub>CC</sub>	Supply Voltage	-0.5	5.5	V
V <sub>CNTRL</sub>	DC Input Voltage (/EN, SEL[1:0]) <sup>(2)</sup>	-0.5	V <sub>CC</sub>	V
V <sub>SW</sub> <sup>(3)</sup>	DC Switch I/O Voltage <sup>(2)</sup>			
	USB, MHL	-0.5	V <sub>CC</sub>	V
I <sub>IK</sub>	DC Input Diode Current	-50		mA
I <sub>OUT</sub>	Switch DC Output Current (Continuous)		60	mA
	USB, MHL			
I <sub>OUTPEAK</sub>	Switch DC Output Peak Current (Pulsed at 1 ms Duration, <10% Duty Cycle)		150	mA
	USB, MHL			
T <sub>STG</sub>	Storage Temperature	-65	+150	°C
MSL	Moisture Sensitivity Level: JEDEC J-STD-020A		1	
ESD	Human Body Model, JEDEC: JESD22-A114	All Pins	4	kV
	IEC 61000-4-2, Level 4, for D+/D- and V <sub>CC</sub> Pins <sup>(4)</sup>	Contact	8	
	IEC 61000-4-2, Level 4, for D+/D- and V <sub>CC</sub> Pins <sup>(4)</sup>	Air	15	
	Charged Device Model, JESD22-C101		2	

### Notes:

- The input and output negative ratings may be exceeded if the input and output diode current ratings are observed.
- V<sub>SW</sub> refers to analog data switch paths (USB, MHL, and audio).
- Testing performed in a system environment using TVS diodes.

## Recommended Operating Conditions

The Recommended Operating Conditions table defines the conditions for actual device operation. Recommended operating conditions are specified to ensure optimal performance to the datasheet specifications. Fairchild does not recommend exceeding them or designing to Absolute Maximum Ratings.

Symbol	Parameter	Min.	Max.	Unit
V <sub>CC</sub>	Supply Voltage	2.5	4.5	V
t <sub>RAMP(VCC)</sub>	Power Supply Slew Rate	100	1000	µs/V
V <sub>CNTRL</sub>	Control Input Voltage (/EN, SEL[1:0]) <sup>(5)</sup>	0	4.5	V
V <sub>SW(USB)</sub>	Switch I/O Voltage (USB Switch Path)	-0.5	3.6	V
Θ <sub>JA</sub>	Thermal Resistance		273	C°/W
V <sub>SW(MHL)</sub>	Switch I/O Voltage (MHL Switch Path)	1.65	3.45	V
T <sub>A</sub>	Operating Temperature	-40	+85	°C

### Note:

- The control inputs must be held HIGH or LOW; they must not float.

## DC Electrical Characteristics

All typical values are at  $T_A = 25^\circ\text{C}$  unless otherwise specified.

Symbol	Parameter	Condition	V <sub>CC</sub> (V)	T <sub>A</sub> =-40°C to +85°C			Unit
				Min.	Typ.	Max.	
V <sub>IK</sub>	Clamp Diode Voltage	I <sub>IN</sub> =-18 mA	2.5			-1.2	V
V <sub>IH</sub>	Control Input Voltage HIGH	SEL[1:0]	2.5	1.3			V
			3.6	1.4			V
			4.5	1.5			V
V <sub>IL</sub>	Control Input Voltage LOW	SEL[1:0]	2.5			0.4	V
			3.6			0.4	V
			4.5			0.4	V
I <sub>IN</sub>	Control Input Leakage SEL[1:0]	V <sub>SW</sub> (MHL & USB)=0 to 3.6 V, V <sub>CNTRL</sub> =0 to V <sub>CC</sub>	4.5	-2.5		2.5	μA
I <sub>OZ(MHL)</sub>	Off-State Leakage for Open MHL Data Paths	V <sub>SW</sub> =1.65 ≤ MHL ≤ 3.45 V, /EN=V <sub>CC</sub> , Figure 6	4.5	-0.5		0.5	μA
I <sub>OZ(USB)</sub>	Off-State Leakage for Open USB Data Paths	V <sub>SW</sub> =0 ≤ USB ≤ 3.6 V, /EN=V <sub>CC</sub> , Figure 6	4.5	-0.5		0.5	μA
I <sub>CL(MHL)</sub>	On-State Leakage for Closed MHL Data Paths <sup>(6)</sup>	V <sub>SW</sub> =1.65 ≤ MHL ≤ 3.45 V, /EN=GND, SEL0=GND, SEL1=V <sub>CC</sub>	4.5	-0.5		0.5	μA
I <sub>CL(USB)</sub>	On-State Leakage for Closed USB Data Paths <sup>(6)</sup>	V <sub>SW</sub> =0 ≤ USB ≤ 3.6 V, /EN=GND, SEL[1:0]=GND and SEL1=GND, SEL0=V <sub>CC</sub>	4.5	-0.5		0.5	μA
I <sub>OFF</sub>	Power-Off Leakage Current (USB & MHL Paths)	V <sub>SW</sub> =0 V or 3.6 V, Figure 6	0	-0.5		0.5	μA
R <sub>ON(USB)</sub>	HS Switch On Resistance (USB <sub>Dn</sub> to D <sub>n</sub> Path)	V <sub>SW</sub> =0.4 V, I <sub>ON</sub> =-8 mA, SEL[1:0]=GND, and SEL1=GND, SEL0=V <sub>CC</sub> Figure 5	2.5 to 4.5		8		Ω
R <sub>ON(MHL)</sub>	HS Switch On Resistance (MHL to D Path)	V <sub>SW</sub> =V <sub>CC</sub> -1050 mV, SEL0=GND, SEL1=V <sub>CC</sub> , I <sub>ON</sub> =-8 mA, Figure 5	2.5 to 4.5		5		Ω
ΔR <sub>ON(MHL)</sub>	Difference in R <sub>ON</sub> Between MHL Positive-Negative	V <sub>SW</sub> =V <sub>CC</sub> -1050 mV, SEL0=GND, SEL1=V <sub>CC</sub> , I <sub>ON</sub> =-8 mA, Figure 5,	2.5 to 4.5		0.03		Ω
ΔR <sub>ON(USB)</sub>	Difference in R <sub>ON</sub> Between USB Positive-Negative	V <sub>SW</sub> =0.4V, I <sub>ON</sub> =-8 mA, SEL[1:0]=GND and SEL1=GND, SEL0=V <sub>CC</sub> , Figure 5	2.5 to 4.5		0.18		Ω
R <sub>ONF(MHL)</sub>	Flatness for R <sub>ON</sub> MHL Path	V <sub>SW</sub> =1.65 V to 3.45 V, SEL0=GND, SEL1=V <sub>CC</sub> , I <sub>ON</sub> =-8 mA, Figure 5	2.5 to 4.5		1		Ω
R <sub>ONFD(USB)</sub>	Flatness for R <sub>ON</sub> USB Path	V <sub>SW</sub> =0 V to 3.6 V, SEL[1:0]=GND and SEL1=GND, SEL0=V <sub>CC</sub> , I <sub>ON</sub> =-8 mA, Figure 5	2.5 to 4.5		2.1		Ω
R <sub>PD</sub>	Internal Pull -Down Resistors on SEL0 & SEL1		2.5 to 4.5		3		MΩ
I <sub>CC</sub>	Quiescent Current	V <sub>CNTRL</sub> =0 or 4.5 V, I <sub>OUT</sub> =0	4.5			30	μA
I <sub>CCZ</sub>	Quiescent Current-High Impedance	V <sub>/EN</sub> =4.5 V, I <sub>OUT</sub> =0	4.5			1	μA
I <sub>CCCT</sub>	Delta Increase in Quiescent Current per Control Pin	V <sub>CNTRL</sub> =1.65 V, I <sub>OUT</sub> =0	4.5			10	μA
		V <sub>CNTRL</sub> =2.5 V, I <sub>OUT</sub> =0	4.5			5	

**Note:**

6. For this test, the data switch is closed with the respective switch pin floating.

## AC Electrical Characteristics

All typical values are for  $V_{CC} = 3.3\text{ V}$  and  $T_A = 25^\circ\text{C}$  unless otherwise specified.

Symbol	Parameter	Condition	$V_{CC}$ (V)	$T_A = -40^\circ\text{C}$ to $+85^\circ\text{C}$			Unit
				Min.	Typ.	Max.	
$t_{ONUSB}$	USB Turn-On Time, SEL[1:0] to Output	$R_L=50\ \Omega$ , $C_L=5\ \text{pF}$ , $V_{SW(USB)}=0.8\ \text{V}$ , $V_{SW(MHL)}=3.3\ \text{V}$ , Figure 7, Figure 8	2.5 to 4.5		445	700	ns
$t_{OFFUSB}$	USB Turn-Off Time, SEL[1:0] to Output	$R_L=50\ \Omega$ , $C_L=5\ \text{pF}$ , $V_{SW(USB)}=0.8\ \text{V}$ , $V_{SW(MHL)}=3.3\ \text{V}$ , Figure 7, Figure 8	2.5 to 4.5		445	600	ns
$t_{ONMHL}$	MHL Turn-On Time, SEL[1:0] to Output	$R_L=50\ \Omega$ to $3.3\ \text{V}$ , $C_L=5\ \text{pF}$ , $V_{SW(USB)}=0.8\ \text{V}$ , $V_{SW(MHL)}=3.3\ \text{V}$ , Figure 7, Figure 8	2.5 to 4.5		445	600	ns
$t_{OFFMHL}$	MHL Turn-Off Time, SEL[1:0] to Output	$R_L=50\ \Omega$ to $3.3\ \text{V}$ , $C_L=5\ \text{pF}$ , $V_{SW(USB)}=0.8\ \text{V}$ , $V_{SW(MHL)}=3.3\ \text{V}$ , Figure 7, Figure 8	2.5 to 4.5		445	600	ns
$t_{ENABLE}$	Enable Turn-On Time, /EN to Output	$R_L=50\ \Omega$ , $C_L=5\ \text{pF}$ , $V_{SW(USB)}=0.8\ \text{V}$ , $V_{SW(MHL)}=3.3\ \text{V}$ , Figure 7, Figure 8	2.5 to 4.5		80		$\mu\text{s}$
$t_{DISABLE}$	Disable Turn-Off Time, /EN to Output	$R_L=50\ \Omega$ , $C_L=5\ \text{pF}$ , $V_{SW(USB)}=0.8\ \text{V}$ , $V_{SW(MHL)}=3.3\ \text{V}$ , Figure 7, Figure 8	2.5 to 4.5		35		ns
$t_{PD}$	Propagation Delay <sup>(7)</sup>	$C_L=5\ \text{pF}$ , $R_L=50\ \Omega$ , Figure 7, Figure 9	2.5 to 4.5		0.25		ns
$t_{BBM}$	Break-Before-Make <sup>(7)</sup>	$R_L=50\ \Omega$ , $C_L=50\ \text{pF}$ , $V_{MHL}=3.3\ \text{V}$ , $V_{USB}=0.8\ \text{V}$ , Figure 11	2.5 to 4.5	50	120	600	ns
$O_{IRR(MHL)}$	Off Isolation <sup>(7)</sup>	$V_S=1\ \text{V}_{pk-pk}$ , $R_L=50\ \Omega$ , $f=24\ \text{MHz}$ , Figure 13	2.5 to 4.5		-36		dB
$O_{IRR(USB)}$		$V_S=400\ \text{mV}_{pk-pk}$ , $R_L=50\ \Omega$ , $f=240\ \text{MHz}$ , Figure 13	2.5 to 4.5		-38		dB
$O_{IRR(UART)}$		$V_S=40\ \text{mV}_{pk-pk}$ , $R_L=50\ \Omega$ , $f=10\ \text{MHz}$ , Figure 13	2.5 to 4.5		-40		dB
$Xtalk_{MHL}$	Non-Adjacent Channel Crosstalk <sup>(7)</sup>	$V_S=1\ \text{V}_{pk-pk}$ , $R_L=50\ \Omega$ , $f=240\ \text{MHz}$ , Figure 14	2.5 to 4.5		-44		dB
$Xtalk_{USB}$		$V_S=400\ \text{mV}_{pk-pk}$ , $R_L=50\ \Omega$ , $f=240\ \text{MHz}$ , Figure 14	2.5 to 4.5		-36		dB
$Xtalk_{UART}$		$V_S=400\ \text{mV}_{pk-pk}$ , $R_L=50\ \Omega$ , $f=10\ \text{MHz}$ , Figure 14	2.5 to 4.5		-36		dB
THD	Total Harmonic Distortion - LINOUT <sup>(7)</sup>	$R_T=600\ \Omega$ , $V_{SW}=2\ \text{V}_{pk-pk}$ , $f=20\ \text{Hz}$ to $20\ \text{kHz}$ , $V_{BIAS}=0\ \text{V}$	2.5 to 4.5		0.01		%
BW	$S_{DD21}$ Differential -3db Bandwidth <sup>(7)</sup>	$V_{IN}=1\ \text{V}_{pk-pk}$ , Common Mode Voltage= $V_{CC} - 1.1\ \text{V}$ , MHL Path, $R_L=50\ \Omega$ , $C_L=0\ \text{pF}$ , Figure 12	2.5 to 4.5		2.0		GHz
		$V_{IN}=400\ \text{mV}_{pk-pk}$ , Common Mode Voltage= $0.2\ \text{V}$ , USB Path, $R_L=50\ \Omega$ , $C_L=0\ \text{pF}$ , Figure 12			650 <sup>(8)</sup>		MHz

### Note:

- Guaranteed by characterization.
- 650 MHz USB Bandwidth, passed USB2.0-Compliant testing.

## USB High-Speed AC Electrical Characteristics

Typical values are at  $T_A=25^{\circ}\text{C}$  and  $V_{CC}=3.0$  to  $3.6$  V.

Symbol	Parameter	Condition	Typ.	Unit
$t_{SK(P)}$	Skew of Opposite Transitions of the Same Output <sup>(9)</sup>	$C_L=5$ pF, $R_L=50$ $\Omega$ , Figure 10	3	ps
$t_J$	Total Jitter <sup>(9)</sup>	$R_L=50$ $\Omega$ , $C_L=5$ pF, $t_R=t_F=500$ ps (10-90%) at 480 Mbps, PN7	20	ps

**Note:**

9. Guaranteed by characterization.

## MHL™ AC Electrical Characteristics

Typical values are at  $T_A=25^{\circ}\text{C}$  and  $V_{CC}=3.0$  to  $3.6$  V.

Symbol	Parameter	Condition	Typ.	Unit
$t_{SK(P)}$	Skew of Opposite Transitions of the Same Output <sup>(10)</sup>	$R_{PU}=50$ $\Omega$ to $V_{CC}$ , $C_L=0$ pF	2	ps
$t_J$	Total Jitter <sup>(10)</sup>	$f=2.25$ Gbps, PN7, $R_{PU}=50$ $\Omega$ to $V_{CC}$ , $C_L=0$ pF	15	ps

**Note:**

10. Guaranteed by characterization.

## Capacitance

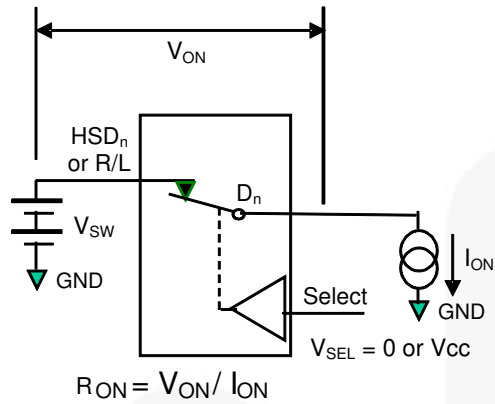
Typical values are at  $T_A = 25^{\circ}\text{C}$ .

Symbol	Parameter	Condition	Typ.	Unit
$C_{IN}$	Control Pin Input Capacitance <sup>(11)</sup>	$V_{CC}=0\text{V}$ , $f=1$ MHz	2.5	pF
$C_{ON(USB)}$	USB Path On Capacitance <sup>(11)</sup>	$V_{CC}=3.3$ V, $f=240$ MHz, Figure 16	5.0	
$C_{OFF(USB)}$	USB Path Off Capacitance <sup>(11)</sup>	$V_{CC}=3.3$ V, $f=240$ MHz, Figure 15	2.5	
$C_{ON(MHL)}$	MHL Path On Capacitance <sup>(11)</sup>	$V_{CC}=3.3$ V, $f=240$ MHz, Figure 16	4.2	
$C_{OFF(MHL)}$	MHL Path Off Capacitance <sup>(11)</sup>	$V_{CC}=3.3$ V, $f=240$ MHz, Figure 15	2.5	

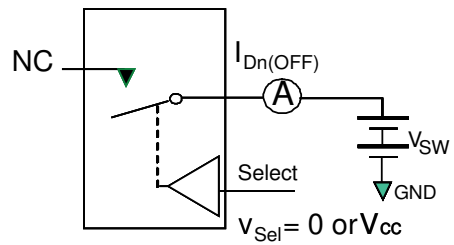
**Note:**

11. Guaranteed by characterization.

### Test Diagrams

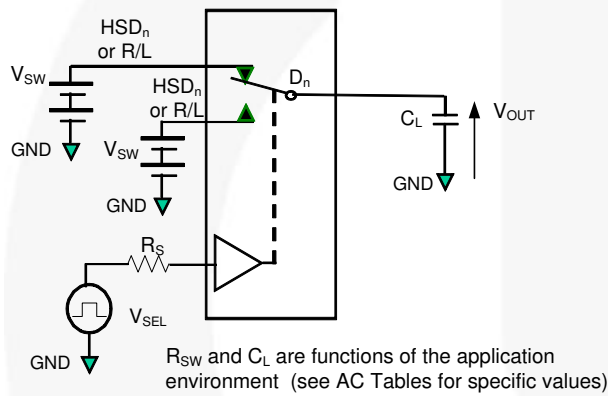


**Figure 5. On Resistance**

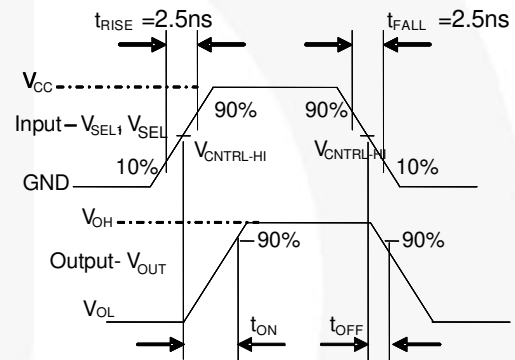


\*\*Each switch port is tested separately

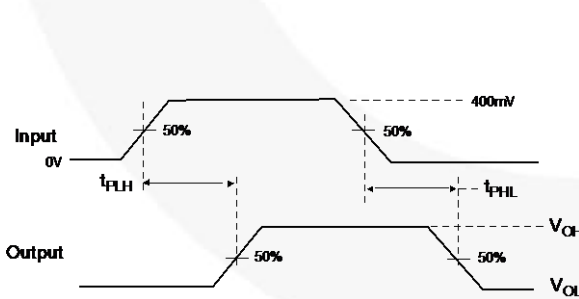
**Figure 6. Off Leakage**



**Figure 7. AC Test Circuit Load**



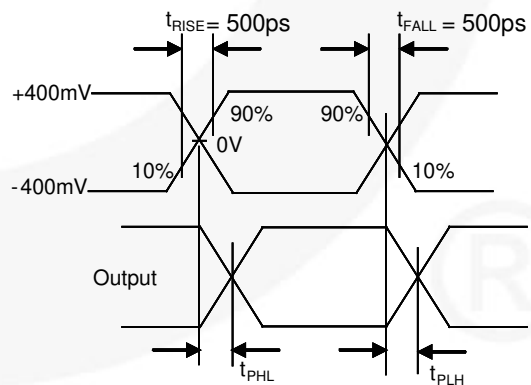
**Figure 8. Turn-On / Turn-Off Waveforms**



**Figure 9. Propagation Delay ( $t_{rF} = 500$  ps)**

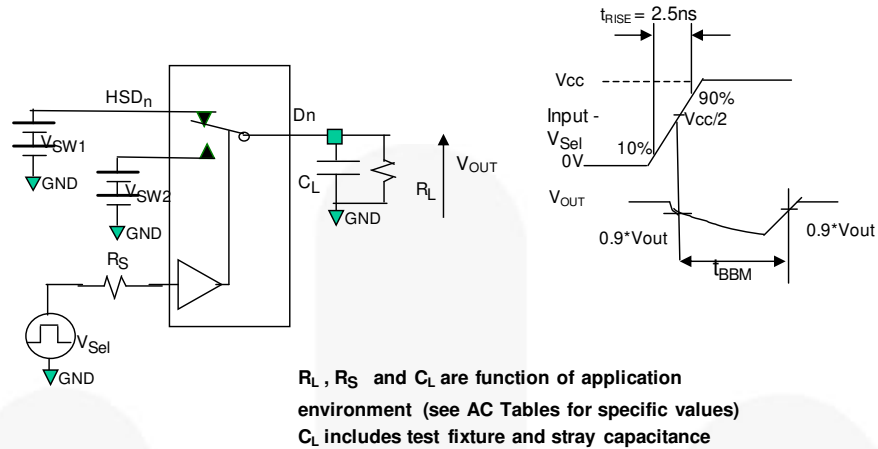
**Note:**

12. HSD<sub>n</sub> refers to the high-speed data USB or MHL paths.

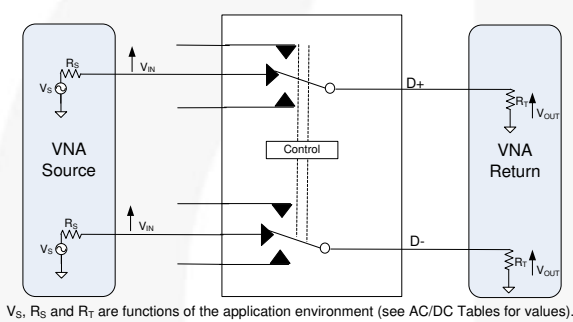


**Figure 10. Intra-Pair Skew Test  $t_{sk(P)}$**

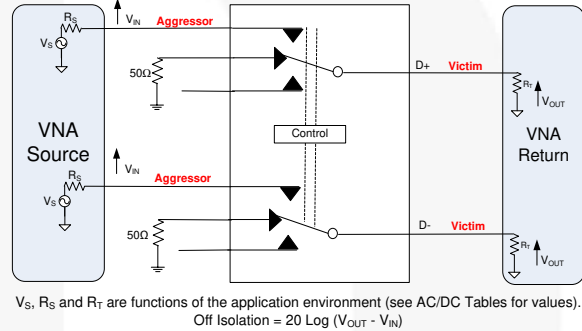
**Test Diagrams (Continued)**



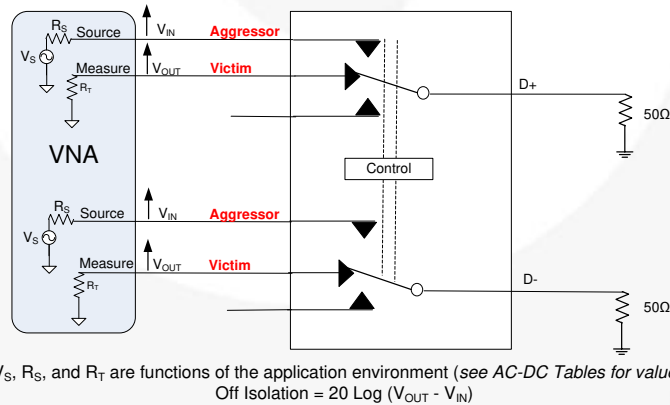
**Figure 11. Break-Before-Make Interval Timing**



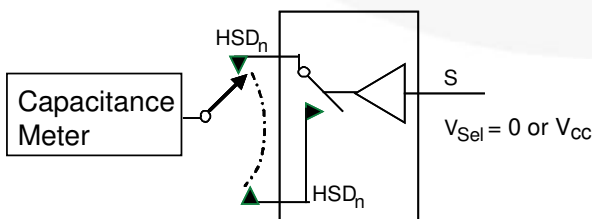
**Figure 12. Insertion Loss (SDD21)**



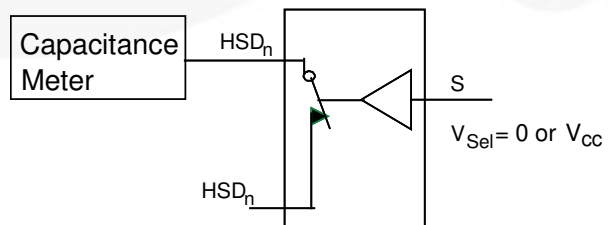
**Figure 13. Channel Off Isolation (SDD21)**



**Figure 14. Non-Adjacent Channel-to-Channel Crosstalk (SDD21)**



**Figure 15. Channel Off Capacitance**



**Figure 16. Channel On Capacitance**



## Functional Description

### Insertion Loss

One of the key advantages of using the FSA3341 in mobile digital-video applications is the small amount of insertion loss experienced by the received signal as it passes through the switch. This results in minimal degradation to the received eye. One of the ways to measure the quality of the high-data-rate channels is using balanced ports and four-port differential S-parameter analysis, particularly SDD21.

Bandwidth is measured using the S-parameter SDD21 methodology.

### Typical Applications

Figure 19 shows the FSA3341 utilizing the  $V_{BAT}$  connection. The 3 M $\Omega$  resistors are used to ensure, for manufacturing test via the micro-USB connector, that the FSA3341 configures for connectivity to the baseband or application processor.

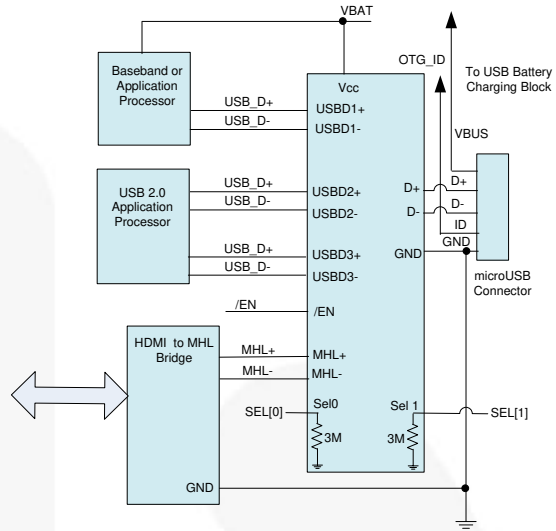


Figure 19. Typical Application



Figure 17. MHL Path SDD21 Insertion Loss Curve

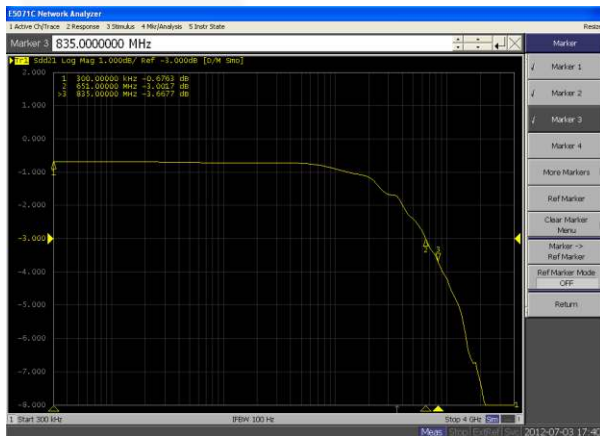
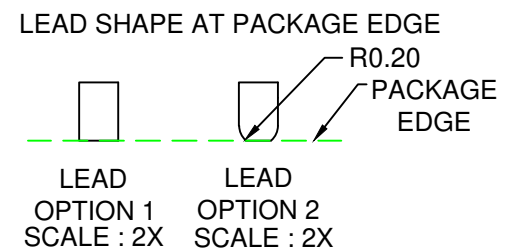
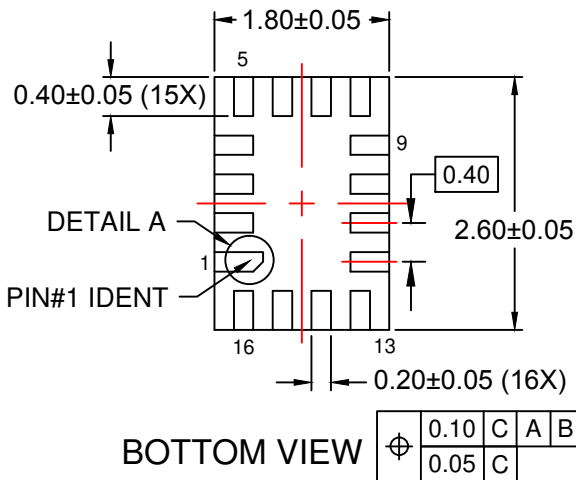
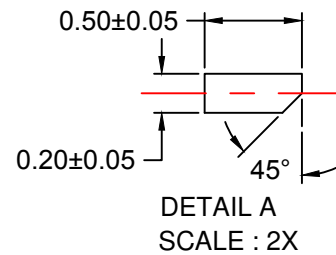
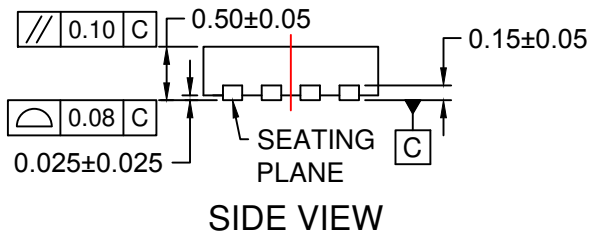
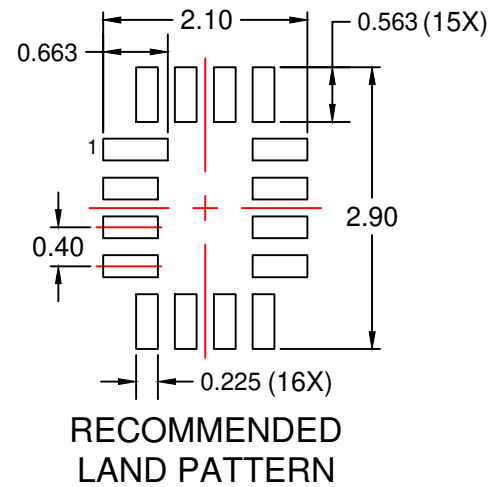
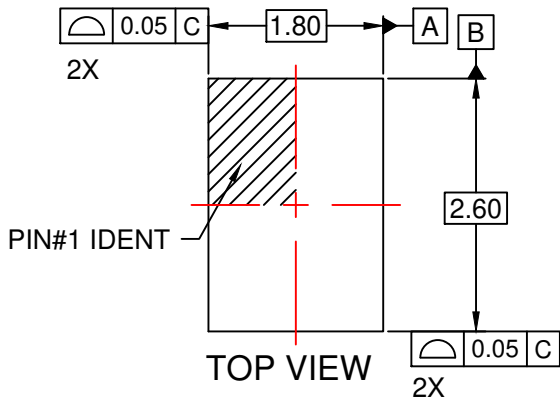


Figure 18. USB Path SDD21 Insertion Loss Curve



**NOTES:**

- A. PACKAGE DOES NOT FULLY CONFORM TO JEDEC STANDARD.
- B. DIMENSIONS ARE IN MILLIMETERS.
- C. DIMENSIONS AND TOLERANCES PER ASME Y14.5M, 2009.
- D. LAND PATTERN RECOMMENDATION IS EXISTING INDUSTRY LAND PATTERN.
- E. DRAWING FILENAME: MKT-UMLP16Arev5.
- F. TERMINAL SHAPE MAY VARY ACCORDING TO PACKAGE SUPPLIER, SEE TERMINAL SHAPE VARIANTS.





### TRADEMARKS

The following includes registered and unregistered trademarks and service marks, owned by Fairchild Semiconductor and/or its global subsidiaries, and is not intended to be an exhaustive list of all such trademarks.

AccuPower™	F-PFS™	OPTOPLANAR®	
AttitudeEngine™	FRFET®		TinyBoost®
Awinda®	Global Power Resource™	PowerXS™	TinyBuck®
AX-CAP®*	GreenBridge™	Programmmable Active Droop™	TinyCalc™
BitSiC™	Green FPS™	QFET®	TinyLogic®
Build it Now™	Green FPS™ e-Series™	QS™	TINYOPTO™
CorePLUS™	Gmax™	Quiet Series™	TinyPower™
CorePOWER™	GTO™	RapidConfigure™	TinyPWM™
CROSSVOLT™	IntelliMAX™		TinyWire™
CTL™	ISOPLANAR™	Saving our world, 1mW/W/kW at a time™	TranSiC™
Current Transfer Logic™	Making Small Speakers Sound Louder and Better™	SignalWise™	TriFault Detect™
DEUXPEED®	MegaBuck™	SmartMax™	TRUECURRENT®*
Dual Cool™	MICROCOUPLER™	SMART START™	SerDes®
EcoSPARK®	MicroFET™	Solutions for Your Success™	UHC®
EfficientMax™	MicroPak™	SPM®	Ultra FRFET™
ESBC™	MicroPak2™	STEALTH™	UniFET™
	MillerDrive™	SuperFET®	VCX™
Fairchild®	MotionMax™	SuperSOT™-3	VisualMax™
Fairchild Semiconductor®	MotionGrid®	SuperSOT™-6	VoltagePlus™
FACT Quiet Series™	MTI®	SupreMOS®	XS™
FACT®	MTX®	SyncFET™	Xsens™
FAST®	MVN®	Sync-Lock™	仙童™
FastvCore™	mWSaver®		
FETBench™	OptoHiT™		
FPS™	OPTOLOGIC®		

\* Trademarks of System General Corporation, used under license by Fairchild Semiconductor.

### DISCLAIMER

FAIRCHILD SEMICONDUCTOR RESERVES THE RIGHT TO MAKE CHANGES WITHOUT FURTHER NOTICE TO ANY PRODUCTS HEREIN TO IMPROVE RELIABILITY, FUNCTION, OR DESIGN. TO OBTAIN THE LATEST, MOST UP-TO-DATE DATASHEET AND PRODUCT INFORMATION, VISIT OUR WEBSITE AT [HTTP://WWW.FAIRCHILDSEMI.COM](http://www.fairchildsemi.com). FAIRCHILD DOES NOT ASSUME ANY LIABILITY ARISING OUT OF THE APPLICATION OR USE OF ANY PRODUCT OR CIRCUIT DESCRIBED HEREIN; NEITHER DOES IT CONVEY ANY LICENSE UNDER ITS PATENT RIGHTS, NOR THE RIGHTS OF OTHERS. THESE SPECIFICATIONS DO NOT EXPAND THE TERMS OF FAIRCHILD'S WORLDWIDE TERMS AND CONDITIONS, SPECIFICALLY THE WARRANTY THEREIN, WHICH COVERS THESE PRODUCTS.

### LIFE SUPPORT POLICY

FAIRCHILD'S PRODUCTS ARE NOT AUTHORIZED FOR USE AS CRITICAL COMPONENTS IN LIFE SUPPORT DEVICES OR SYSTEMS WITHOUT THE EXPRESS WRITTEN APPROVAL OF FAIRCHILD SEMICONDUCTOR CORPORATION.

As used herein:

1. Life support devices or systems are devices or systems which, (a) are intended for surgical implant into the body or (b) support or sustain life, and (c) whose failure to perform when properly used in accordance with instructions for use provided in the labeling, can be reasonably expected to result in a significant injury of the user.
2. A critical component in any component of a life support, device, or system whose failure to perform can be reasonably expected to cause the failure of the life support device or system, or to affect its safety or effectiveness.

### ANTI-COUNTERFEITING POLICY

Fairchild Semiconductor Corporation's Anti-Counterfeiting Policy. Fairchild's Anti-Counterfeiting Policy is also stated on our external website, [www.fairchildsemi.com](http://www.fairchildsemi.com), under Sales Support.

Counterfeiting of semiconductor parts is a growing problem in the industry. All manufacturers of semiconductor products are experiencing counterfeiting of their parts. Customers who inadvertently purchase counterfeit parts experience many problems such as loss of brand reputation, substandard performance, failed applications, and increased cost of production and manufacturing delays. Fairchild is taking strong measures to protect ourselves and our customers from the proliferation of counterfeit parts. Fairchild strongly encourages customers to purchase Fairchild parts either directly from Fairchild or from Authorized Fairchild Distributors who are listed by country on our web page cited above. Products customers buy either from Fairchild directly or from Authorized Fairchild Distributors are genuine parts, have full traceability, meet Fairchild's quality standards for handling and storage and provide access to Fairchild's full range of up-to-date technical and product information. Fairchild and our Authorized Distributors will stand behind all warranties and will appropriately address any warranty issues that may arise. Fairchild will not provide any warranty coverage or other assistance for parts bought from Unauthorized Sources. Fairchild is committed to combat this global problem and encourage our customers to do their part in stopping this practice by buying direct or from authorized distributors.

### PRODUCT STATUS DEFINITIONS

#### Definition of Terms

Datasheet Identification	Product Status	Definition
Advance Information	Formative / In Design	Datasheet contains the design specifications for product development. Specifications may change in any manner without notice.
Preliminary	First Production	Datasheet contains preliminary data; supplementary data will be published at a later date. Fairchild Semiconductor reserves the right to make changes at any time without notice to improve design.
No Identification Needed	Full Production	Datasheet contains final specifications. Fairchild Semiconductor reserves the right to make changes at any time without notice to improve the design.
Obsolete	Not In Production	Datasheet contains specifications on a product that is discontinued by Fairchild Semiconductor. The datasheet is for reference information only.

Rev. I73