

Customer Information Sheet

DRAWING No.: M80-5C1XX05M3

IF IN DOUBT - ASK

©

NOT TO SCALE

THIRD ANGLE PROJECTION

ALL DIMENSIONS IN mm

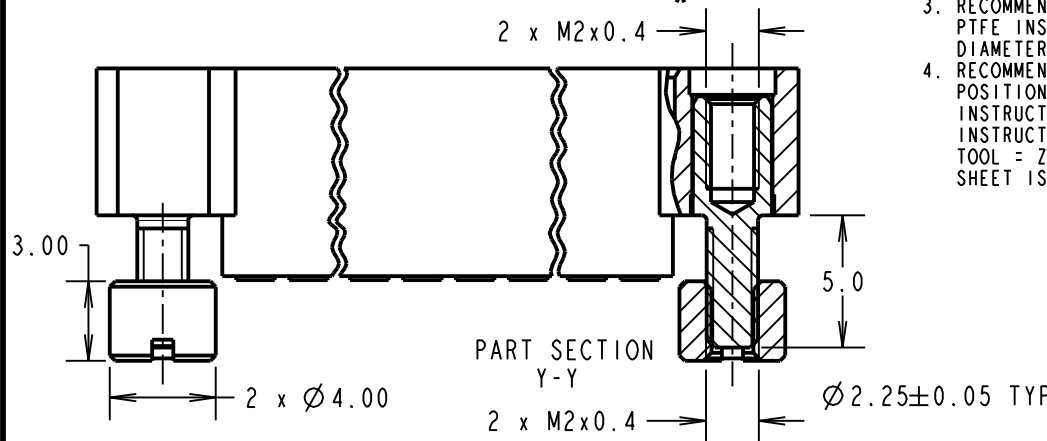
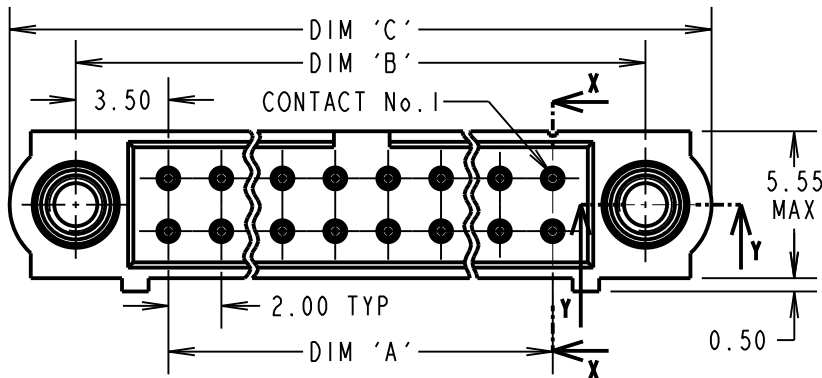

SECTION X-X

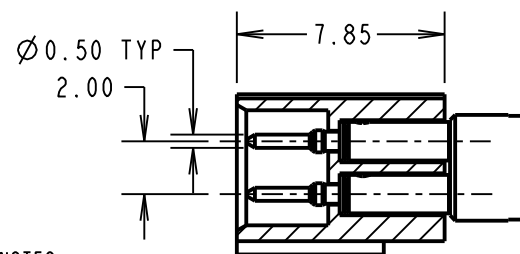

NOTES:

- CONNECTORS ARE SUPPLIED WITH CONTACTS AND NUTS LOOSE.
- FOR EXTRA CONTACTS, USE PART NUMBER M80-1950005.
- RECOMMENDED WIRE TYPE = BS 3G 210 TYPE A, PTFE INSULATED 24-28 AWG. MAX INSULATION DIAMETER = Ø1.10mm, STRIP WIRE BY 2.00mm.
- RECOMMENDED HAND CRIMP TOOL = M22520/2-01 WITH POSITIONER Z80-193. REFER TO TOOLING INSTRUCTION SHEET IS-01 FOR COMPLETE CRIMPING INSTRUCTIONS. CONTACT INSERTION & EXTRACTION TOOL = Z80-280. REFER TO TOOLING INSTRUCTION SHEET IS-25 FOR ASSEMBLY INSTRUCTIONS.

SPECIFICATIONS:

MATERIAL:
 MOULDING = GLASS-FILLED PPS, UL94V-0, BLACK
 CONTACT = BRASS
 JACKSCREW & BOARDMOUNT = STAINLESS STEEL FINISH
 CONTACT = 0.25-0.3µ GOLD
 ELECTRICAL:
 CURRENT RATING AT 25°C = 3.0A MAX
 CURRENT RATING AT 85°C = 2.2A MAX
 WORKING VOLTAGE = 800V AC/DC
 VOLTAGE PROOF = 1200V AC/DC
 CONTACT RESISTANCE = 25mΩ MAX
 INSULATION RESISTANCE = 100MΩ MIN
 MECHANICAL:
 DURABILITY = 500 OPERATIONS
 ENVIRONMENTAL:
 TEMPERATURE RANGE = -55°C TO +125°C
 PACKING:
 BAG
 FOR COMPLETE SPECIFICATION, SEE COMPONENT SPECIFICATION C005XX (LATEST ISSUE)

RECOMMENDED PANEL CUT OUT

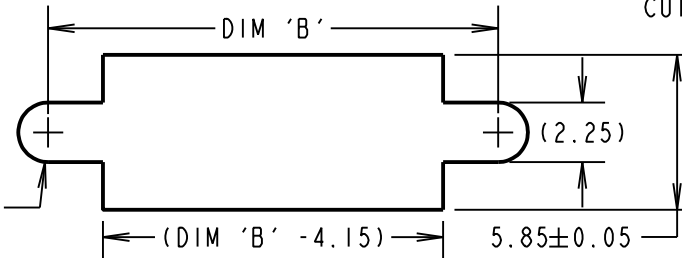

DIMENSION	CALCULATION
DIM 'A'	TOTAL No. OF CONTACTS - 2
DIM 'B'	TOTAL No. OF CONTACTS + 5
DIM 'C'	TOTAL No. OF CONTACTS + 10
EXAMPLE: CONNECTOR WITH 20 CONTACTS, ALL OVER GOLD M80-5C12005M3	
DIM 'A' = 18.00mm, DIM 'B' = 25.00mm, DIM 'C' = 30.00mm	

ORDER CODE:

M80-5C1XX05M3

TOTAL No. OF CONTACTS
 04 TO 50
 (EVEN NUMBERS ONLY)

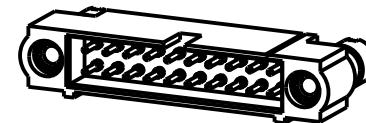

LS	3	31.10.17	13269
NAME	ISS.	DATE	C/NOTE
APPROVED: LS			
CHECKED: SB			
DRAWN: R.ADDE			
CUSTOMER REF.:			
ASSEMBLY DRG:			

HARWIN

www.harwin.com
 technical@harwin.com

THIS DRAWING AND ANY INFORMATION OR DESCRIPTIVE MATTER SET OUT HEREON ARE CONFIDENTIAL AND COPYRIGHT PROPERTY OF THE HARWIN GROUP AND MUST NOT BE DISCLOSED, LOANED, COPIED OR USED FOR MANUFACTURING, TENDERING OR FOR ANY OTHER PURPOSE WITHOUT THEIR WRITTEN PERMISSION.

TOLERANCES
 X. = ±1mm
 X.X = ±0.50mm
 X.XX = ±0.10mm
 X.XXX = ±0.01mm
 ANGLES = ±5°
 UNLESS STATED

MATERIAL:

SEE ABOVE

FINISH: SEE ABOVE

S/AREA:

mm²

TITLE: DATAMATE J-TEK
 MALE CRIMP ASSY (SMALL BORE)
 WITH BOARDMOUNT JACKSCREW

DRAWING NUMBER:

M80-5C1XX05M3

SHT
 2 OF 2