

Light click™

1. Introduction

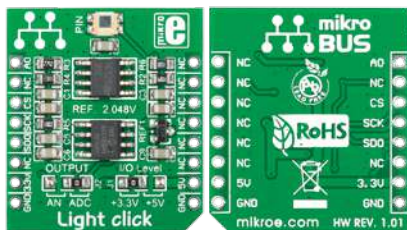

Light Click™ is an accessory board in **mikroBUS™** form factor. It's a compact and easy solution for adding light sensor to your design. It features **PD15-22C-TR8** PIN photodiode, **MAX6106** voltage reference and **MCP3201** ADC with SPI interface. Light Click™ communicates with the target board microcontroller via **mikroBUS™** SPI (MISO, SCK, CS) and AN lines. The board is designed to use 3.3V and 5V power supply. LED diode (GREEN) indicates the presence of power supply.

2. Soldering the headers

Before using your click board™, make sure to solder 1x8 male headers to both left and right side of the board. Two 1x8 male headers are included with the board in the package.

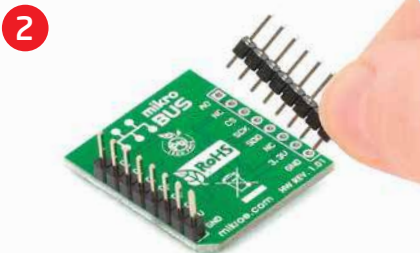

Turn the board upside down so that bottom side is facing you upwards. Place shorter parts of the header pins in both soldering pad locations.

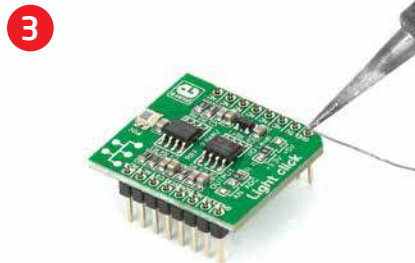

Turn the board upward again. Make sure to align the headers so that they are perpendicular to the board, then solder the pins carefully.

3. Plugging the board in

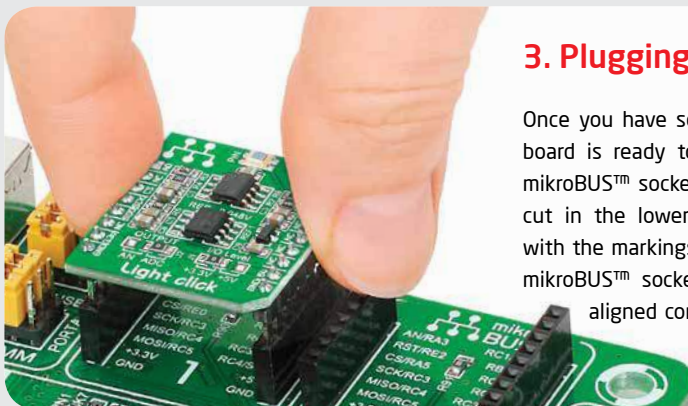

Once you have soldered the headers your board is ready to be placed into desired mikroBUS™ socket. Make sure to align the cut in the lower-right part of the board with the markings on the silkscreen at the mikroBUS™ socket. If all of the pins are aligned correctly, push the board all the way into the socket.

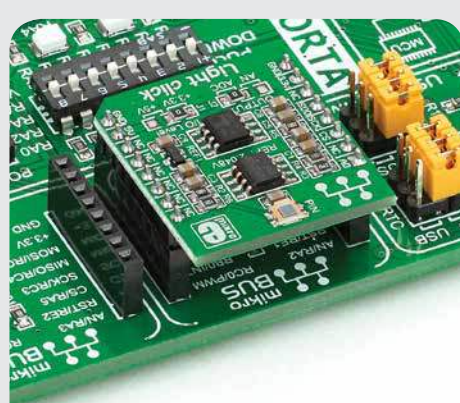

4. Essential features

Light Click™ with it's **PD15-22C-TR8** and **MCP3201** ICs is a high photosensitive light sensor with fast response time. The board is capable of measuring ambient light intensity and provides a signal (analog or digital) to the main board microcontroller. All these features make this board ideal for high speed photo detector, copier, game machine and many more.



Light click Manual
ver. 1.01



0 100000 023761

5. Light Click™ Board Schematic

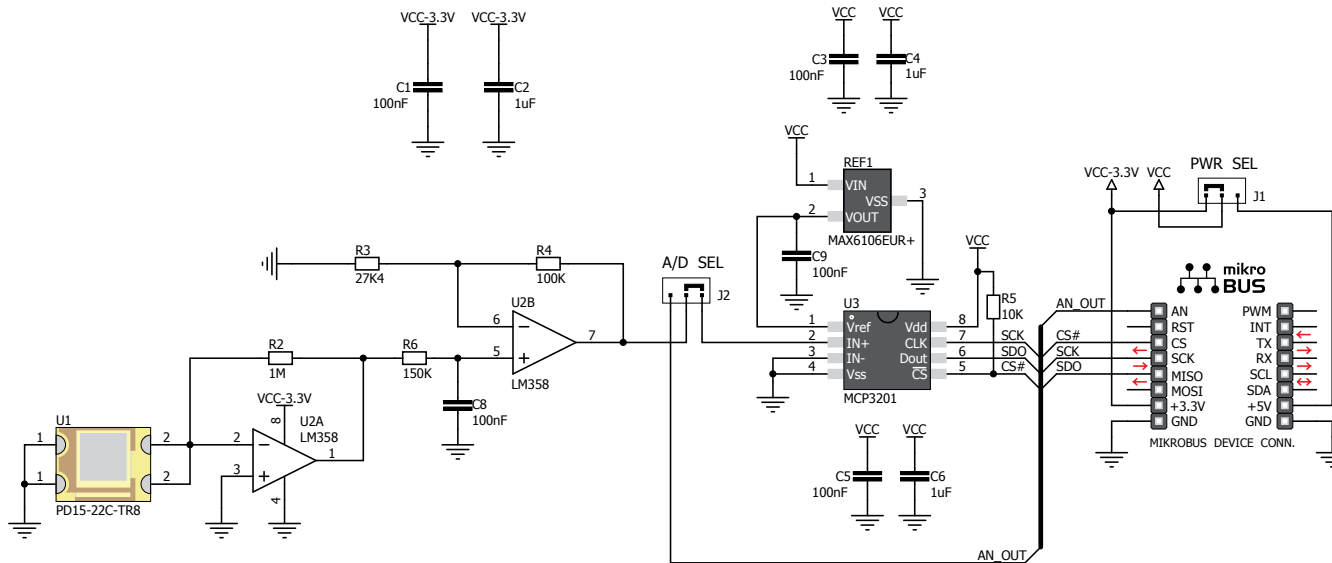

6. SMD Jumpers



The Light Click™ board communicates with the main board microcontroller via I²C interface (ADC) or directly through the analog pin (AN) depending on the position of the **J2** SMD jumper (ADC position by default). There is one zero-ohm SMD jumper **J1** used to select whether 3.3V or 5V power supply will be used. (3.3V position by default).

7. Code Examples

Once you have done all the necessary preparations, it's time to get your click board up and running. We have provided the examples for mikroC, mikroBasic and mikroPascal compilers on our **Libstock** website. Just download them and you are ready to start.



8. Support

MikroElektronika offers **Free Tech Support** (www.mikroe.com/esupport) until the end of product lifetime, so if something goes wrong, we are ready and willing to help!