

**STRAIGHT BULKHEAD JACK PANEL SEAL
FULL CRIMP-TYPE - CABLE 5/50 S**

R161.329.000
SERIES N

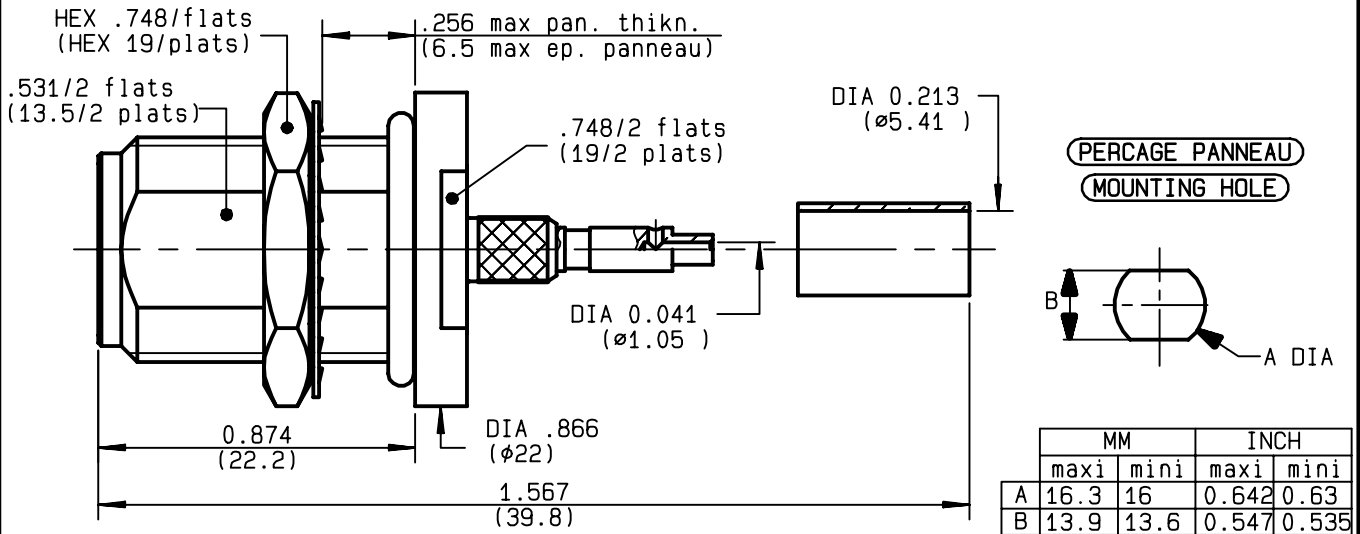

	MM		INCH	
	maxi	mini	maxi	mini
A	16.3	16	0.642	0.63
B	13.9	13.6	0.547	0.535

NOMINAL IMPEDANCE	50 Ω
FREQUENCY RANGE	0-11 GHz
TEMPERATURE RATING	-55/+155 °C
V.S.W.R	* + x F(GHz)Maxi
RF INSERTION LOSS	0.048 √F(GHz) dB Maxi
VOLTAGE RATING	850 Veff Maxi
DIELECTRIC WITHSTANDING VOLTAGE	1500 Veff Mini
INSULATION RESISTANCE	5000 MΩMini
HERMETIC SEAL	NA Atm.cm ³ /s
LEAKAGE (pressurized only)	IP 67
MECHANICAL DURABILITY	500 Cycles
WEIGHT	36.3 gr
SPECIFICATION	* 1.30 0->8GHz / 1.40 8->11GHz

CABLES : **BSSM 742**
KX 15
RG 141
RG 58

OTHERS CHARACTERISTICS

CABLE RETENTION	150 N Mini
CENTER CONTACT RETENTION	
Axial force - mating end	27 N Mini
Axial force - opposite end	27 N Mini
Torque	NA cm.N Mini
RECOMMENDED TORQUES	
Mating	NA cm.N
Panel nut	500 cm.N
Clamp nut	NA cm.N

CONNECTOR PARTS	MATERIALS	FINISH	(all values are given in micrometers)
BODY	BRASS	BBR 2	
OUTER CONTACT			
CENTER CONTACT	BERYLLIUM COPPER	GOLD 0.5 OVER NICKEL 2	
INSULATOR	PTFE	-	
GASKET	SILICONE RUBBER	-	
OTHERS PIECES	BRASS	BBR 2	

BONOMINI

ISSUE	CREATION DATE	FILE PART-NUMBER
9820C01	21/07/1993	EPC 96-07



RADIALL®

The information given here is subject to change without notice.
Design changes may be in order to improve the product .

Connect to the future



R161.329.000

ISSUE **9820C01** SERIES **N**

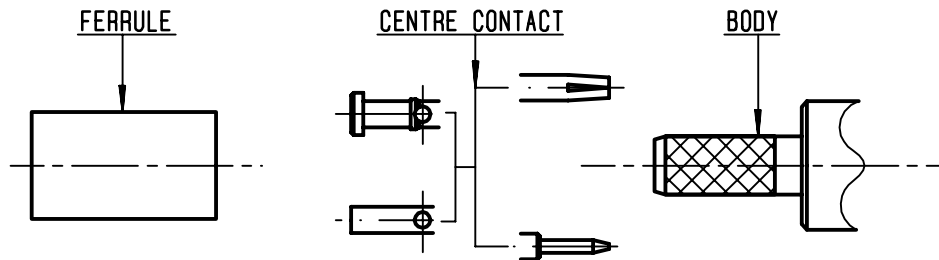

①

Slide onto the cable the ferrule
Strip the cable .

-
-

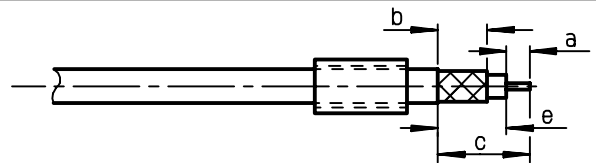

Stripping	a	b	c	d	e
inch	0.177	0.315	0.551	0	0.374
mm	4.5	8	14		9.5

②

Slide on centre contact until it bottoms against cable dielectrique .
Solder or crimp centre contact .
Crimping tool : R282 223 000 (Hex. : .068)
or R282 293 000 (M22520/5-01)
+ dies R282 235 011 (M22520/5-11) .

-
-

SOLDER / CRIMPING

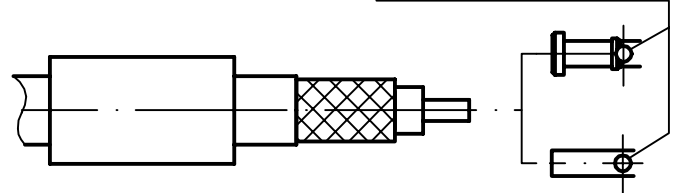

③

Fan the braid .
Slide cable into the body until bottoms against insulator .
Slide ferrule over the braid .
(In direction F)

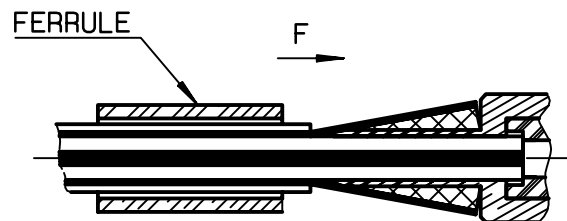

④

Crimp the ferrule with crimping tool R 282 223 000 (Hex. : .213) or crimping tool R282 293 000 (M22520/5-01)
+ dies R282 235 011 (M22520/5-11)
Cut the excess of braid .

-
-

