

*i*MEMS ADXL345/ADXL346 Inertial Sensor Datalogger and Development Board

FEATURES

- Ultralow power [ADXL345/ADXL346](#) accelerometer
- Inertial sensor development board
- Datalogs onto MicroSD card
- Fully programmable via serial interface; firmware examples provided
- Battery-powered for portable applications

REQUIREMENTS

- 2 AAA batteries
- MicroSD card and card reader (for datalogging)
- Computer with serial port (for programming)

GENERAL DESCRIPTION

It is often a timesaver in hardware development to make progress on the firmware and the hardware simultaneously. The challenge is that it proves difficult to develop firmware before the hardware exists. The *i*MEMS® ADXL345/ADXL346 development board is an easy-to-use tool that facilitates prototyping by providing a platform that can be duplicated in the final application. Additionally, the development board can be configured as a datalogger and can be used to gather data for refining algorithms, tuning thresholds, and generally familiarizing oneself with accelerometer data.

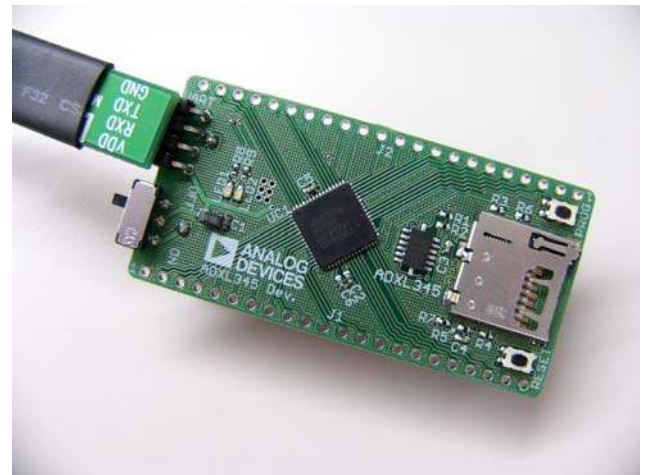

Figure 1. ADXL345 Inertial Sensor Development Board

Two AAA batteries power the development board, and thus it integrates seamlessly into portable applications. Communications and processing are done by an ARM7-based [ADuC7024](#) microcontroller, and the interface provided is fully reprogrammable. Moreover, all ADuC7024 pins are broken out into headers to facilitate design of compatible expansion boards. Data is logged onto a MicroSD memory card, providing essentially unlimited memory capacity and operating system versatility. Data is stored in a text file; therefore, there is no need to install any software to operate the board or read data. Software is provided to assist with programming the board.

TABLE OF CONTENTS

Features	1	Getting Started.....	4
Requirements	1	Programming the Board.....	4
General Description	1	Software Tools.....	5
Revision History	2	Evaluation Board Schematic and Layout	6
Overview.....	3	Appendix: Sample Output File	10
Features	3		
Using the Board	4		

REVISION HISTORY

3/11—Rev. 0 to Rev. A

Added ADXL346 Throughout	Universal
Changes to Firmware Section	3
Changes to Figure 7.....	8
Changes to Figure 8.....	9
Added Appendix.....	10

6/10—Revision 0: Initial Version

OVERVIEW

The [ADXL345/ADXL346](#) inertial sensor development board has the following features:

- A 2-layer printed circuit board (PCB), 1.20 inches × 2.30 inches form factor
- A two AAA battery power supply
- A 4-pin UART header to connect to an RS-232 interface cable
- Reset/download push buttons
- Power indicator/general-purpose LEDs
- Access to microcontroller I/Os from the external header
- Demonstration firmware logs 100 Hz acceleration data

FEATURES

Power Supply

A pair of AAA batteries powers the board, and the battery holder is located on the back of the board. An on/off switch on the lower left of the front of the board controls power to it. The battery voltage is not regulated but is decoupled with a 10 μF capacitor globally and an additional 1 μF capacitor at the device supply pins to ground.

RS-232 Interface

The [ADuC7024](#) (UC1) P1.1 and P1.0 lines are connected to the RS-232 interface cable via the connector (UART). The interface cable generates the required level shifting to allow direct connection to a PC serial port. Ensure that the supplied cable is connected to the board correctly; that is, VDD is connected to VDD and GND is connected to GND.

RESET/PROG Push Buttons

A **RESET** push button is provided to allow the user to manually reset the part. When the **RESET** button is inserted, the $\overline{\text{RST}}$ pin

of the ADuC7024 is pulled to GND. Because the $\overline{\text{RST}}$ pin is Schmitt-triggered internally, there is no need to use an external Schmitt trigger on this pin.

To enter serial download mode, the user must hold the P0.0/BM pin low while reset is toggled. On the development board, serial download mode can be easily initiated by holding down the serial download push button (PROG) while inserting and releasing the reset button (RESET), as illustrated in Figure 2.

Power Indicator/General-Purpose LEDs

Two general-purpose LEDs are available on the board. A red LED (LED1) is connected to P4.5 of the ADuC7024, and a green LED (LED2) is connected to P4.4. Both LEDs can be reprogrammed via firmware.

Breakout Header

Many of the ADuC7024 pins are connected to headers on either side of the board. The headers come unpopulated but can be populated using standard 0.1 inch header pins.

The thin form factor of the top of the board allows the design of an expansion board to connect above the development board, with the header pins providing both electrical and physical connections.

Firmware

Sample firmware is provided on the ADXL345 product page under the **Development Board** heading. The **Firmware** link downloads a Keil project that implements the 100 Hz datalogging firmware. This project can be modified as needed.

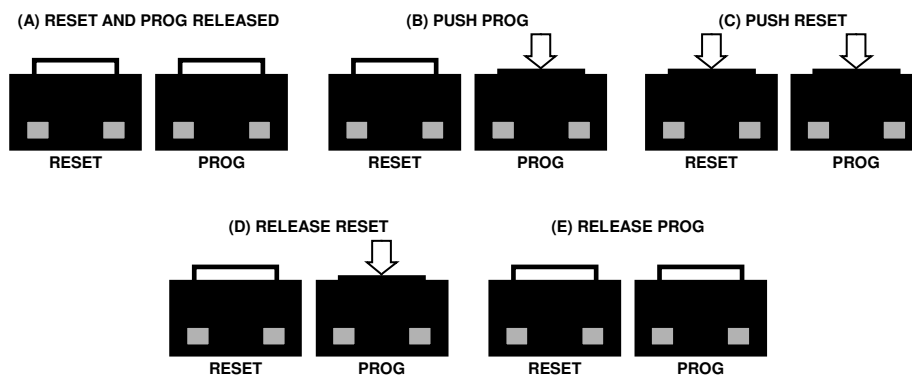

Figure 2. Entering Serial Download Mode to Reprogram the Board

200-99960

USING THE BOARD

GETTING STARTED

The development board comes preprogrammed as a datalogger at a 100 Hz datarate. To log data, do the following:

1. Insert two AAA batteries into the battery holder.
2. Insert the MicroSD card into the slot. The card should be formatted with a FAT32 file system; most MicroSD cards come this way.
3. Push the on/off switch to the on position to power up the board. The red LED turns on, and the green LED blinks to indicate that the board is logging data.
4. When logging is completed, slide the on/off switch to the off position.
5. Remove the card from the slot and insert it into the card reader.
6. Insert the card reader into the USB port on your computer.

The acceleration log file is written to the path \XL345\DATA0000.TXT on the MicroSD card. The data in the text file consists of a set of comma-separated t, x, y, and z values, where t corresponds to time and x, y, and z correspond to the x-, y-, and z-axis acceleration data for each time point. Refer to the Appendix: Sample Output File for an example of a data file. Acceleration values are logged in LSB, where the nominal scale factor is 3.9 mg/LSB. To convert an acceleration value from LSB to mg, simply multiply by 3.9 (nominally, or measure the sensitivity of the part for a more accurate conversion).

To plot the logged data using Microsoft® Excel, download the **Plotting Tool** (XL345DB_DataPlotter.xls) from the [ADXL345 product page](#) (under the **Development Board** heading) and follow the instructions described in the file. Users are prompted to browse to their logged data file (DATA0000.TXT), the data is imported and plotted in a new workbook, and users are then prompted to save that workbook.

PROGRAMMING THE BOARD

The board can be repurposed with no programming required using the .hex files provided on the ADXL345 product page. The .hex files are uploaded onto the board using the ARMWSD program, which can be downloaded at www.analog.com/static/imported-files/eval_boards/ARMWSDv1.8.zip. Simply unzip the folder to a known location and open the ARMWSD.exe file to use the program. No installation is required.

To reprogram the board, use the cable provided with the board and follow these instructions:

1. Download the desired .hex file from the ADXL345 product page to a known location, or locate it on your machine.
2. Open ARMWSD.

3. Click **Configure...** (see Figure 3) and select the **Parts** tab, shown in Figure 4. Make sure the **ADuC7024** is selected in the **Select Part** pull-down list (see Figure 4). Additionally, in the **Comms** tab, make sure the **Baudrate** is set to 115200, and the **Serial Port** is set to COM1, and then click **OK**.
4. In the ARMWSD window, click **Browse...** (see circled in Figure 3) and navigate to the location of the .hex file to be loaded onto the board. Select the file and click **Open**.

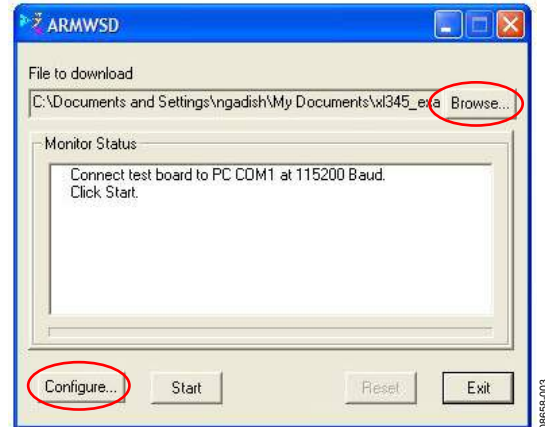

Figure 3. ARMWSD Window

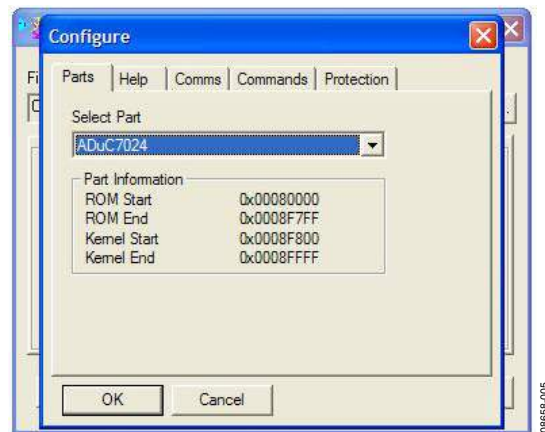

Figure 4. ARMWSD Configure Window: Parts Tab

5. Connect the programming cable to the serial port on the PC and to the 4-pin header near the on/off switch on the board, matching up the corresponding pins.
6. In the ARMWSD window, click **Start**. The Status frame then prompts users to **Press Download and pulse Reset on Hardware**. Follow the illustrations in Figure 2.
7. When download is complete, click the **Reset** button on the evaluation board. Users can now close the ARMWSD program.

SOFTWARE TOOLS

In addition to the ready-to-upload examples provided in the **Firmware** link of the **Development Board** section of the [ADXL345](#) product page, the development board is fully modifiable and reprogrammable to allow for easy prototyping and firmware development. Firmware is written in C, and it is compiled for the [ADuC7024](#) ARM7 processor.

The firmware examples provided on the ADXL345 product page were written using Keil Microvision and compiled using the RealView compiler. A free evaluation version of Keil Microvision is available online. Additional [software suites](#) (Keil, IAR, and GNU) for writing and compiling code are available.

For instructions on how to install and use the software, refer to the [ADuC702x MicroConverter™ GetStarted Guide](#).

To reprogram the board, download the ARMWSD program from the **Uploader** link in the **Development Board** section of the ADXL345 product page.

When Keil Microvision is installed, complete the following steps:

1. Click and download the **Sample Project (EVAL-ADXL345Z-DB Files.zip)** file from the **ADXL345 Development Board** section of the ADXL345 product page.
2. Unzip the **EVAL-ADXL345Z-DB Files.zip** file into a known directory.
3. Navigate into the **EVAL-ADXL345Z-DB** folder and open **datalogger.uvproj**. This Keil Microvision project allows users to modify and recompile the program.

EVALUATION BOARD SCHEMATIC AND LAYOUT

See the appropriate product pages for electronic versions of the layout and schematic files.

000-95980

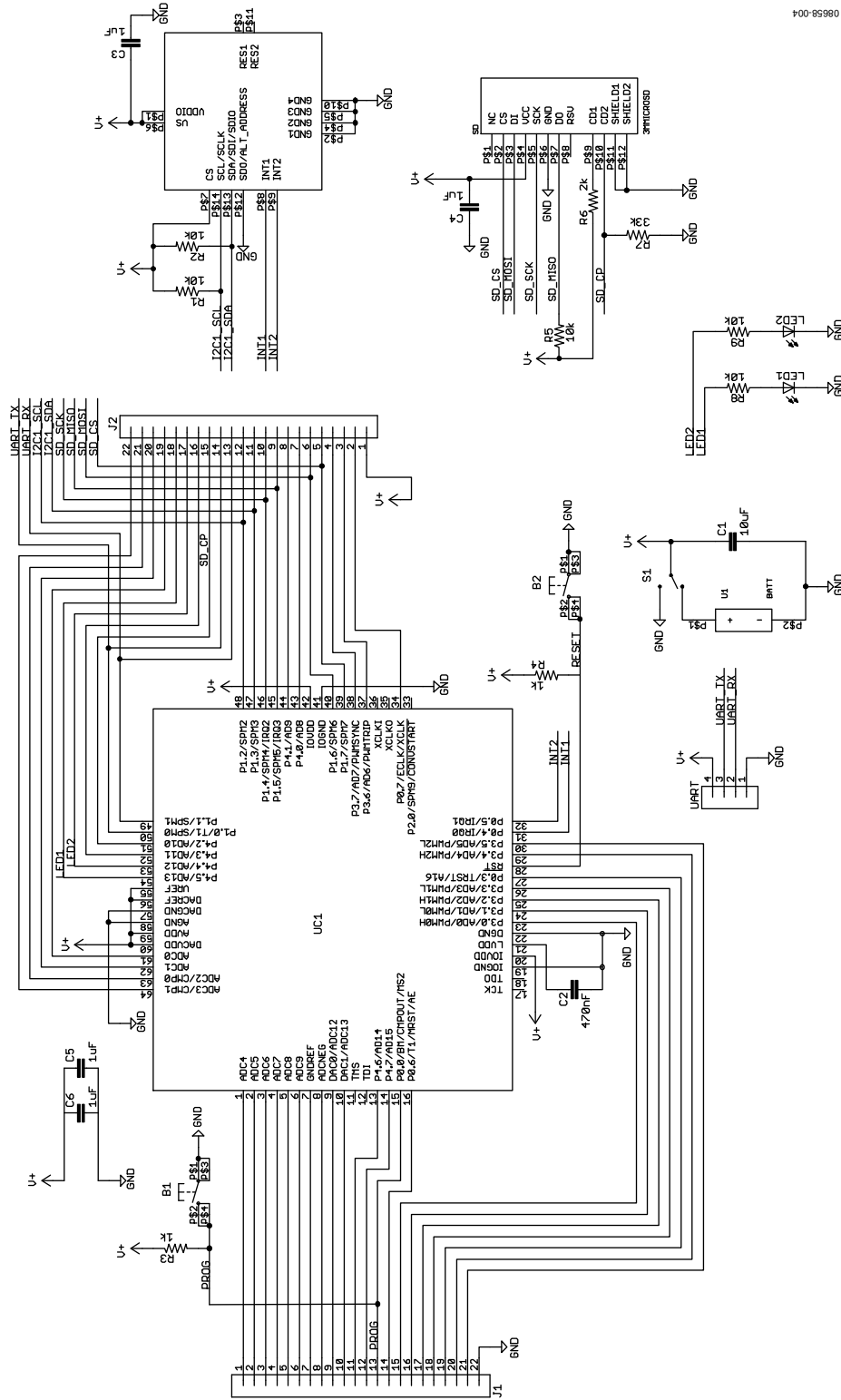

Figure 5. ADXL345 Development Board Schematic

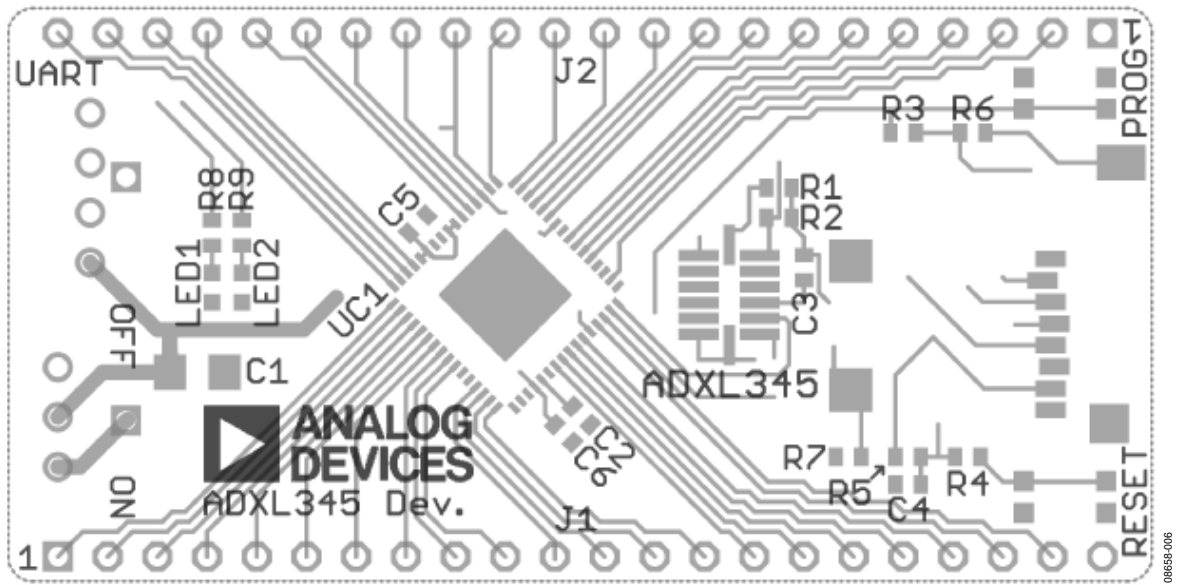

Figure 6. ADXL345 Development Board Layout

800-65960

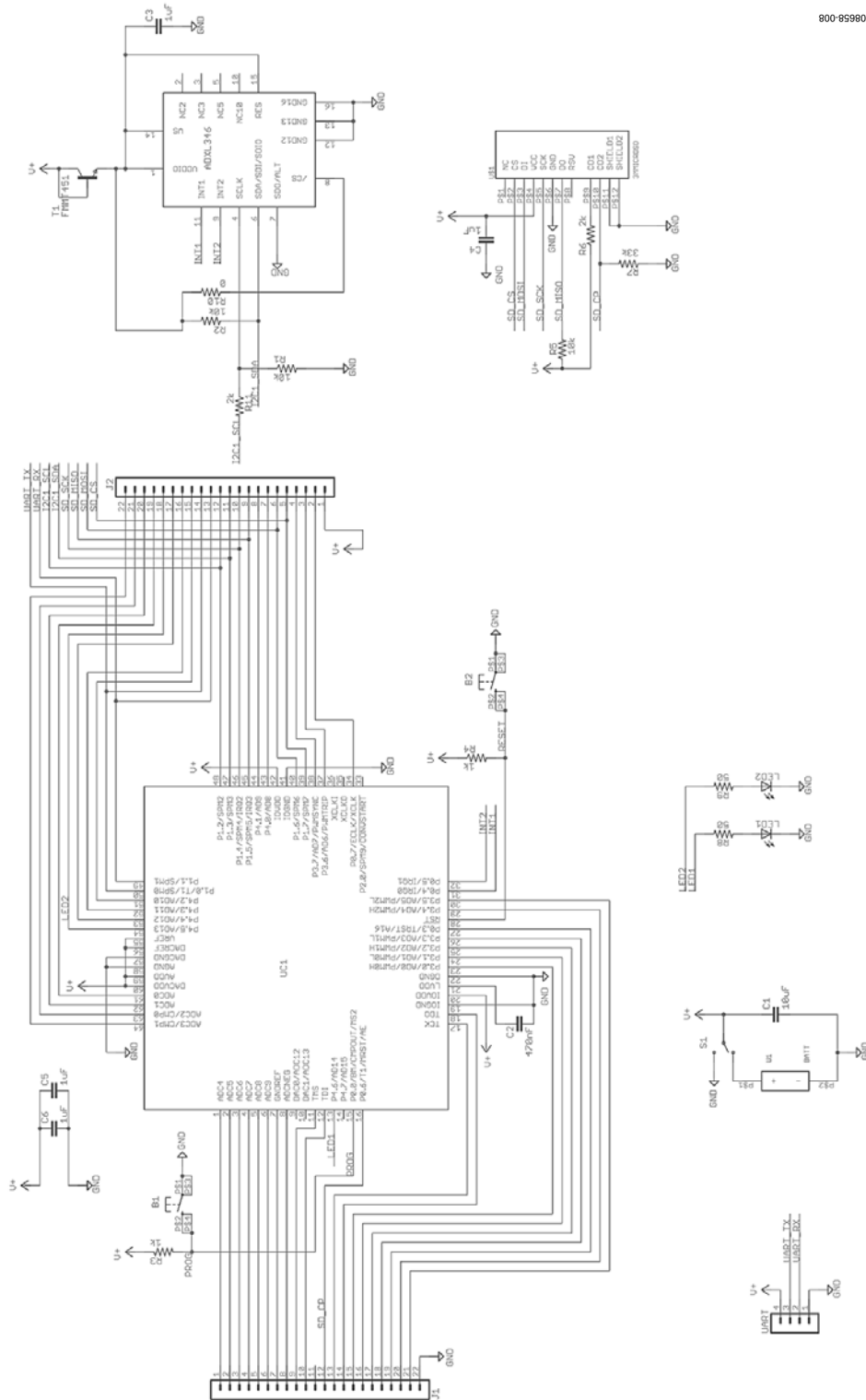

Figure 7. ADXL346 Development Board Schematic

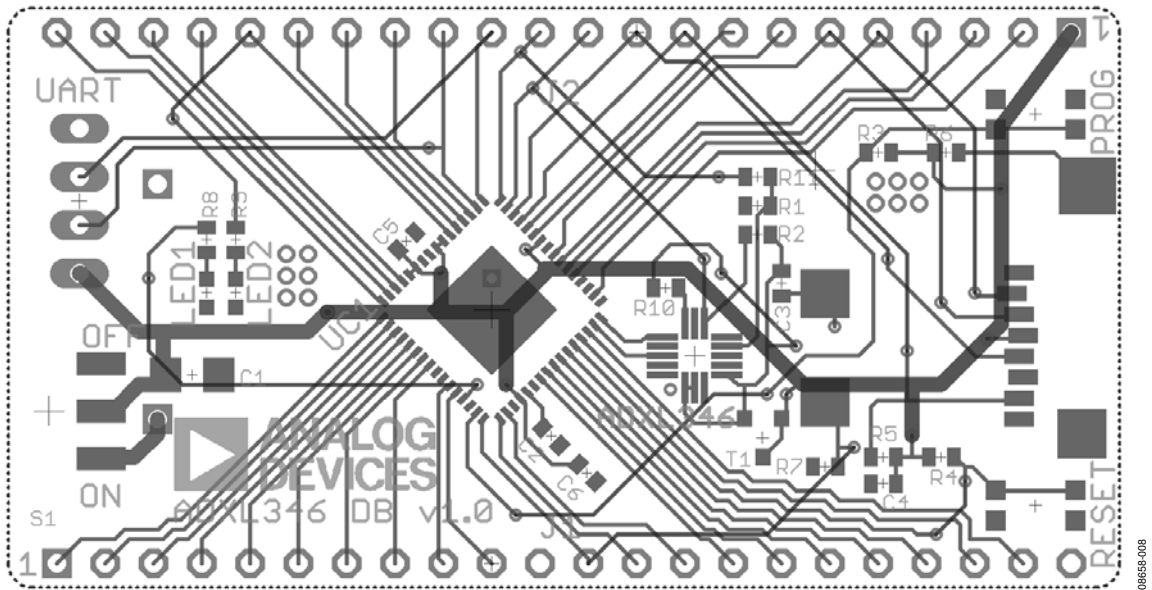

Figure 8. ADXL346 Development Board Layout

APPENDIX: SAMPLE OUTPUT FILE

t, x, y, z

0, 60, 20, 247

50, 60, 19, 259

100, 57, 17, 258

151, 58, 18, 260

201, 61, 14, 252

252, 58, 10, 252

302, 63, 21, 248

353, 66, 23, 255

403, 67, 21, 243

454, 53, 35, 254

504, 63, 32, 251

555, 63, 31, 241

605, 65, 33, 256

656, 59, 34, 254

706, 60, 34, 247

757, 55, 41, 250

807, 56, 41, 252

858, 58, 43, 245

908, 60, 40, 246

959, 60, 38, 246

1009, 66, 37, 249

1060, 64, 29, 252

1110, 69, 36, 251

1161, 68, 31, 253

1211, 66, 47, 233

1262, 63, 40, 246

1312, 59, 36, 246

1363, 48, 41, 244

1413, 49, 41, 248

1464, 46, 51, 252

1514, 52, 39, 264

1565, 47, 42, 260

1576, 47, 43, 254

1585, 25, -5, 263

1595, 26, -2, 263

1605, 26, -5, 257

1615, 26, -4, 257

1625, 28, -3, 258

1634, 28, -1, 261

1644, 24, -2, 263

1654, 24, 1, 263

1664, 25, 0, 261

1674, 27, 0, 263

1683, 24, -2, 263

1693, 22, -1, 265

1703, 23, -2, 264

1713, 22, 0, 265

1723, 22, 0, 260

1732, 22, -1, 261

1742, 23, 0, 258

1752, 23, -1, 259

1762, 25, -1, 256

1772, 26, -1, 256

1781, 21, -2, 257

1791, 21, -4, 256

1801, 20, -4, 259

1811, 21, -2, 260

1821, 19, -5, 260

1830, 17, -4, 258

1840, 18, -3, 260

1850, 20, -5, 260

1860, 20, -2, 260

1870, 20, -2, 261

1870, 20, -2, 264

1880, 25, 2, 264

1890, 23, 2, 262

1901, 25, -1, 260

1911, 24, 0, 264

1922, 27, 1, 263

1932, 30, 0, 265

1942, 30, 2, 265

1953, 27, 2, 263

1963, 28, 1, 263

1974, 27, 1, 264

1984, 29, 0, 261

1994, 29, 0, 263

2005, 27, 0, 261

2015, 26, 0, 259

2026, 28, -1, 257

2036, 26, -3, 257

2046, 27, -2, 259

2057, 23, -1, 262

2067, 24, -3, 261

NOTES

NOTES

**ESD Caution**

ESD (electrostatic discharge) sensitive device. Charged devices and circuit boards can discharge without detection. Although this product features patented or proprietary protection circuitry, damage may occur on devices subjected to high energy ESD. Therefore, proper ESD precautions should be taken to avoid performance degradation or loss of functionality.

Legal Terms and Conditions

By using the evaluation board discussed herein (together with any tools, components documentation or support materials, the "Evaluation Board"), you are agreeing to be bound by the terms and conditions set forth below ("Agreement") unless you have purchased the Evaluation Board, in which case the Analog Devices Standard Terms and Conditions of Sale shall govern. Do not use the Evaluation Board until you have read and agreed to the Agreement. Your use of the Evaluation Board shall signify your acceptance of the Agreement. This Agreement is made by and between you ("Customer") and Analog Devices, Inc. ("ADI"), with its principal place of business at One Technology Way, Norwood, MA 02062, USA. Subject to the terms and conditions of the Agreement, ADI hereby grants to Customer a free, limited, personal, temporary, non-exclusive, non-sublicensable, non-transferable license to use the Evaluation Board FOR EVALUATION PURPOSES ONLY. Customer understands and agrees that the Evaluation Board is provided for the sole and exclusive purpose referenced above, and agrees not to use the Evaluation Board for any other purpose. Furthermore, the license granted is expressly made subject to the following additional limitations: Customer shall not (i) rent, lease, display, sell, transfer, assign, sublicense, or distribute the Evaluation Board; and (ii) permit any Third Party to access the Evaluation Board. As used herein, the term "Third Party" includes any entity other than ADI, Customer, their employees, affiliates and in-house consultants. The Evaluation Board is NOT sold to Customer; all rights not expressly granted herein, including ownership of the Evaluation Board, are reserved by ADI. CONFIDENTIALITY. This Agreement and the Evaluation Board shall all be considered the confidential and proprietary information of ADI. Customer may not disclose or transfer any portion of the Evaluation Board to any other party for any reason. Upon discontinuation of use of the Evaluation Board or termination of this Agreement, Customer agrees to promptly return the Evaluation Board to ADI. ADDITIONAL RESTRICTIONS. Customer may not disassemble, decompile or reverse engineer chips on the Evaluation Board. Customer shall inform ADI of any occurred damages or any modifications or alterations it makes to the Evaluation Board, including but not limited to soldering or any other activity that affects the material content of the Evaluation Board. Modifications to the Evaluation Board must comply with applicable law, including but not limited to the RoHS Directive. TERMINATION. ADI may terminate this Agreement at any time upon giving written notice to Customer. Customer agrees to return to ADI the Evaluation Board at that time. LIMITATION OF LIABILITY. THE EVALUATION BOARD PROVIDED HEREUNDER IS PROVIDED "AS IS" AND ADI MAKES NO WARRANTIES OR REPRESENTATIONS OF ANY KIND WITH RESPECT TO IT. ADI SPECIFICALLY DISCLAIMS ANY REPRESENTATIONS, ENDORSEMENTS, GUARANTEES, OR WARRANTIES, EXPRESS OR IMPLIED, RELATED TO THE EVALUATION BOARD INCLUDING, BUT NOT LIMITED TO, THE IMPLIED WARRANTY OF MERCHANTABILITY, TITLE, FITNESS FOR A PARTICULAR PURPOSE OR NON-INFRINGEMENT OF INTELLECTUAL PROPERTY RIGHTS. IN NO EVENT WILL ADI AND ITS LICENSORS BE LIABLE FOR ANY INCIDENTAL, SPECIAL, INDIRECT, OR CONSEQUENTIAL DAMAGES RESULTING FROM CUSTOMER'S POSSESSION OR USE OF THE EVALUATION BOARD, INCLUDING BUT NOT LIMITED TO LOST PROFITS, DELAY COSTS, LABOR COSTS OR LOSS OF GOODWILL. ADI'S TOTAL LIABILITY FROM ANY AND ALL CAUSES SHALL BE LIMITED TO THE AMOUNT OF ONE HUNDRED US DOLLARS (\$100.00). EXPORT. Customer agrees that it will not directly or indirectly export the Evaluation Board to another country, and that it will comply with all applicable United States federal laws and regulations relating to exports. GOVERNING LAW. This Agreement shall be governed by and construed in accordance with the substantive laws of the Commonwealth of Massachusetts (excluding conflict of law rules). Any legal action regarding this Agreement will be heard in the state or federal courts having jurisdiction in Suffolk County, Massachusetts, and Customer hereby submits to the personal jurisdiction and venue of such courts. The United Nations Convention on Contracts for the International Sale of Goods shall not apply to this Agreement and is expressly disclaimed.