

IN700-485 Series

INTESIS PROTOCOL TRANSLATOR WITH SERIAL AND IP SUPPORT

USER MANUAL
Version 1.4.1
Publication date 2023-05-15



Copyright © 2022 Intesis

Disclaimer

The information in this document is for informational purposes only. Please inform HMS Networks of any inaccuracies or omissions found in this document. HMS Networks disclaims any responsibility or liability for any errors that may appear in this document.

HMS Networks reserves the right to modify its products in line with its policy of continuous product development. The information in this document shall therefore not be construed as a commitment on the part of HMS Networks and is subject to change without notice. HMS Networks makes no commitment to update or keep current the information in this document.

The data, examples and illustrations found in this document are included for illustrative purposes and are only intended to help improve understanding of the functionality and handling of the product. In view of the wide range of possible applications of the product, and because of the many variables and requirements associated with any particular implementation, HMS Networks cannot assume responsibility or liability for actual use based on the data, examples or illustrations included in this document nor for any damages incurred during installation of the product. Those responsible for the use of the product must acquire sufficient knowledge in order to ensure that the product is used correctly in their specific application and that the application meets all performance and safety requirements including any applicable laws, regulations, codes and standards. Further, HMS Networks will under no circumstances assume liability or responsibility for any problems that may arise as a result from the use of undocumented features or functional side effects found outside the documented scope of the product. The effects caused by any direct or indirect use of such aspects of the product are undefined and may include e.g. compatibility issues and stability issues.

Table of Contents

1. Order Codes	1
2. General Information	2
2.1. Intended Use of the User Manual	2
2.2. General Safety Information	2
2.3. Admonition Messages and Symbols	2
3. General Introduction	4
4. Modbus Master to BACnet Server	5
4.1. Specific Gateway Introduction	5
4.2. Functionality	5
5. BACnet Client to Modbus Server	6
5.1. Specific Gateway Introduction	6
5.2. Functionality	6
6. BACnet Client to ASCII	7
6.1. Specific Gateway Introduction	7
6.2. Functionality	7
7. Gateway Capacity	8
8. BACnet Interface	9
8.1. General Description	9
8.2. BACnet Client	10
8.2.1. Description	10
8.2.2. Points Definition	11
8.3. BACnet Server	12
8.3.1. Description	12
8.3.2. BACnet/IP	13
8.3.3. BACnet MS/TP	13
9. Modbus Interface	14
9.1. General Description	14
9.2. Modbus Server Interface	14
9.2.1. Description	14
9.2.2. Functions Supported	14
9.2.3. Modbus RTU	15
9.2.4. Modbus TCP	15
9.2.5. Modbus Server Interface Points Definition	16
9.3. Modbus Client Interface	16
9.3.1. Description	16
9.3.2. Points Definition	17
10. ASCII Interface	18
10.1. Description	18
10.2. ASCII Serial	18
10.3. ASCII TCP	18
10.4. Address Map	18
10.5. Points Definition	19
10.6. Messages	20

11. Mounting	21
12. Connections	22
12.1. Power Supply	22
12.2. Connection Diagrams for each Application	24
12.3. Connection to Modbus	27
12.4. Connection to BACnet	28
12.5. Connection to ASCII	29
12.6. Console and USB Connections	30
13. Set-up Process with the Configuration Tool	31
13.1. Prerequisites	31
13.2. Intesis MAPS: Configuration and Monitoring Tool	31
13.2.1. Introduction	31
13.2.2. Template Selection	32
13.2.3. Connection Tab	33
13.2.4. Configuration Tab	33
13.2.5. Signals Tab	34
13.2.6. Receive/Send Tab	34
13.2.7. Diagnostic Tab	35
14. Technical Specifications	37
15. Dimensions	38

1. Order Codes

ORDER CODE	LEGACY ORDER CODE		
IN7004851000000	INMBSBAC1000000	INBACMBM1000000	-
IN7004852500000	INMBSBAC2500000	INBACMBM2500000	-
IN7004856000000	INMBSBAC6000000	INBACMBM6000000	INASCBAC6000000
IN7004851K20000	INMBSBAC1K20000	INBACMBM1K20000	-
IN7004853K00000	INMBSBAC3K00000	INBACMBM3K00000	INASCBAC3K00000

PRODUCT NAME	ORDER CODE	DESCRIPTION	INTESIS MAPS TEMPLATE	APPLICATION
IN700-485	IN700485xxx*0000	Intesis Protocol Translator with Serial and IP Support	IN-BAC-MBM	Modbus master to BACnet server
			IN-MBS-BAC	BACnet client to Modbus server
			IN-ASCII-BAC	BACnet client to ASCII

**xxx defines the Intesis gateway capacity.*

2. General Information

2.1. Intended Use of the User Manual

This manual contains the main features of this Intesis gateway and the instructions for its appropriate installation, configuration, and operation.

The contents of this manual should be brought to the attention of any person who installs, configures, or operates this gateway or any associated equipment.

Keep this manual for future reference during the installation, configuration, and operation.

2.2. General Safety Information



IMPORTANT

Follow these instructions carefully. Improper work may seriously harm your health and damage the gateway and/or any other equipment connected to it.

Only technical personnel, following these instructions and the country legislation for installing electrical equipment, can install and manipulate this gateway.

Install this gateway indoors, in a restricted access location, avoiding exposure to direct solar radiation, water, high relative humidity, or dust.

All wires (for communication and power supply, if needed) must only be connected to networks with indoor wiring. All communication ports are considered for indoor use and must only be connected to SELV circuits.

Disconnect all systems from their power source before manipulating and connecting them to the gateway.

Supply always a correct voltage to power the gateway. See [Technical Specifications \(page 37\)](#).

Respect the expected polarity of power and communication cables when connecting them to the gateway.



CAUTION

Only an authorized installer is allowed to replace the battery. There's a risk of explosion if the battery is replaced by an incorrect type. Dispose of used batteries according to local legislation.

Safety instructions in other languages can be found at <https://intesis.com/docs/manuals/v6-safety>

2.3. Admonition Messages and Symbols



DANGER

Instructions that must be followed to avoid an imminently hazardous situation that, if not avoided, will result in death or severe injury.



WARNING

Instructions that must be followed to avoid a potentially hazardous situation that, if not avoided, could result in death or severe injury.



CAUTION

Instruction that must be followed to avoid a potentially hazardous situation that, if not avoided, could result in minor or moderate injury.

**IMPORTANT**

Instruction that must be followed to avoid a risk of reduced functionality and/or damage to the equipment or to avoid a network security risk.

**NOTE**

Additional information which may facilitate installation and/or operation.

**TIP**

Helpful advice and suggestions.

**NOTICE**

Remarkable Information.

3. General Introduction

This Intesis® gateway allows you to integrate Serial and IP protocols easily.

This document describes the available applications for this gateway:

- Modbus® TCP & RTU Client to BACnet®/IP & MS/TP Server.
- BACnet/IP & MS/TP Client to Modbus TCP & RTU Server.
- BACnet/IP & MS/TP Client to ASCII IP & Serial.



IMPORTANT

This document assumes that the user is familiar with BACnet, Modbus, and ASCII technologies and their technical terms.



NOTE

Some sections provide general information common to all applications, while others highlight specific differences, capacities, or limitations.

In general terms, you must have a BACnet, Modbus, or ASCII control and monitoring system on one side and a Modbus or BACnet installation or device on the other side (only one at a time).



IMPORTANT

The Intesis gateway can act as a server or client for BACnet and Modbus but only as a server for ASCII.

As always, the configuration process is fast and easy:

1. Launch the configuration tool.
2. Select the template.
3. Connect the Intesis gateway to the PC.
4. Adjust the configuration and signals to your project.
5. Send the configuration to the gateway.

And you are ready to go!

4. Modbus Master to BACnet Server

4.1. Specific Gateway Introduction

This section describes the integration of Modbus RTU and/or Modbus TCP devices into BACnet/IP or MS/TP installations using the **Modbus master to BACnet server** application.

This integration allows a BACnet control system to access the signals and resources of Modbus devices as if they were part of the BACnet system itself and vice versa.

The gateway configuration is carried out through the configuration tool.

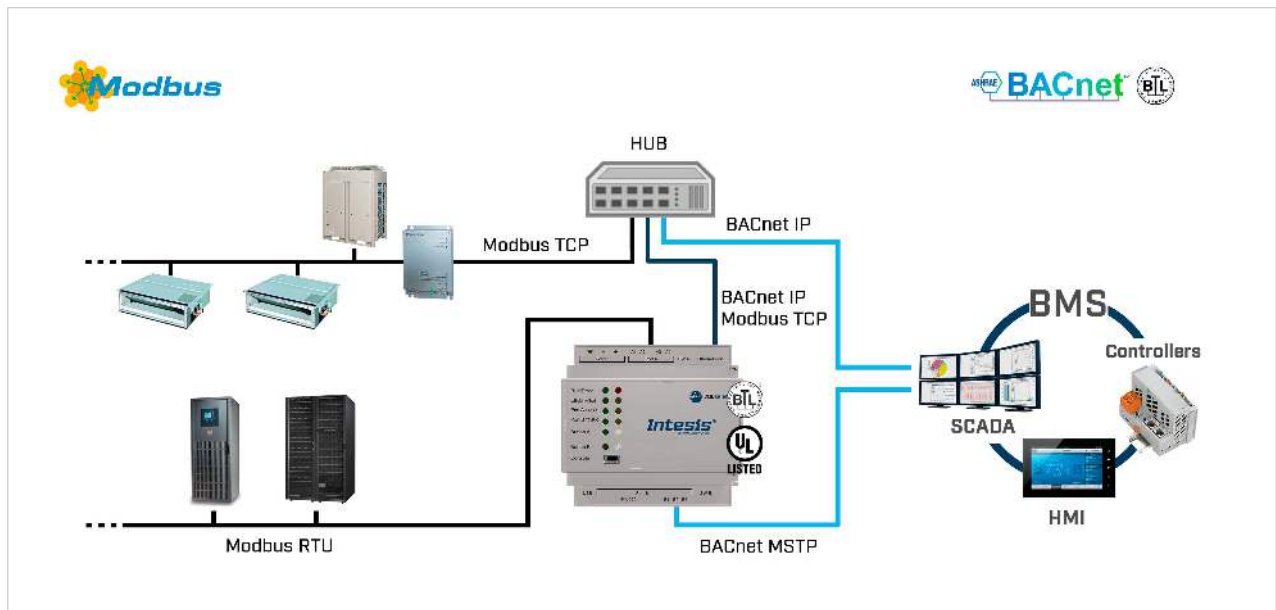

Figure 1. Integration of Modbus RTU or TCP devices into BACnet/IP or MS/TP installations

4.2. Functionality

From the Modbus point of view, the gateway continuously polls the installation or devices, storing in its memory the values of the points that you previously configured to be read. On the other hand, from the BACnet point of view, the control and monitoring system reads and writes those stored points.

This is possible because, inside the gateway, all Modbus registers of the server devices are associated with BACnet objects. This makes the BACnet control and monitoring system perceive the Modbus installation (all the server devices) as if it were a single BACnet device.

When the gateway polls the Modbus devices, if a non-response is detected, the corresponding virtual signal inside the gateway will be activated, indicating the communication error to the BACnet system.

The gateway has two EIA-485 ports for Modbus RTU integration: Port A and Port B. This function allows you to integrate up to 64 devices (32 in each port) with no additional repeaters in the network.

This functionality is disabled when BACnet MS/TP is selected in Intesis MAPS, leaving only Port A available for Modbus RTU connectivity and Port B for BACnet MS/TP devices.

By default, Port A is configured for Modbus RTU and Port B for BACnet MS/TP.

5. BACnet Client to Modbus Server

5.1. Specific Gateway Introduction

This section describes the integration of BACnet MS/TP and BACnet/IP devices into Modbus RTU or TCP installations using the **BACnet client to Modbus server** application of the Intesis gateway.

This integration allows a Modbus control system to access the signals and resources of BACnet devices as if they were part of the Modbus system itself and vice versa.

The gateway configuration is carried out through the configuration tool.

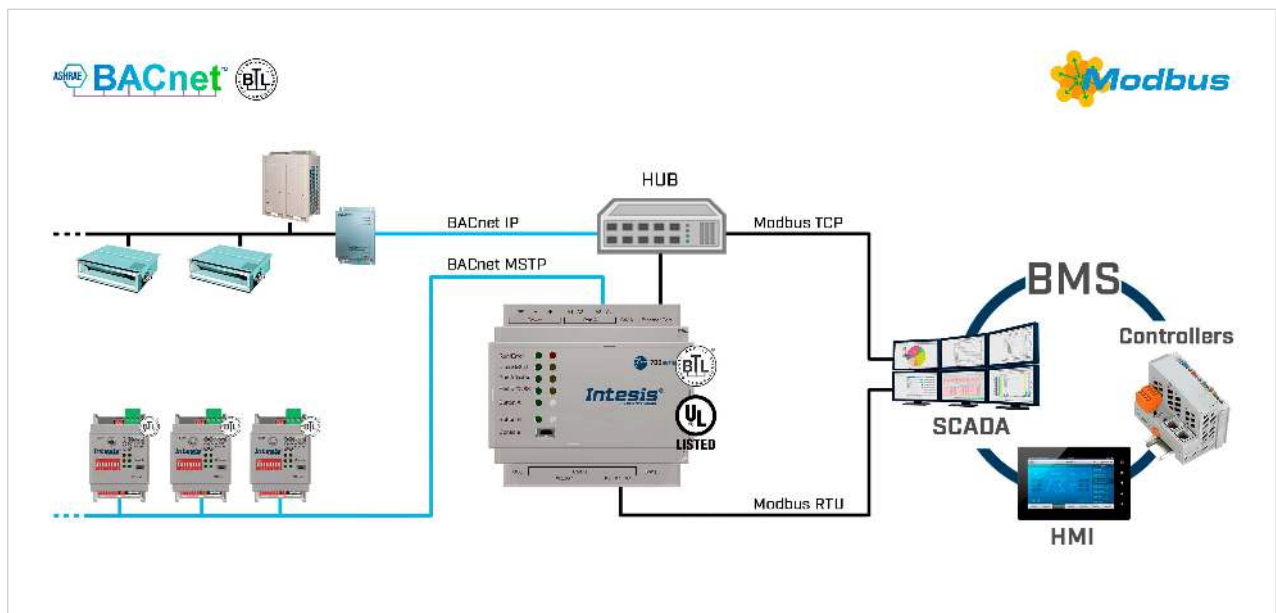

Figure 2. Integration of BACnet/IP or MS/TP devices into Modbus TCP or RTU installations

5.2. Functionality

From the BACnet point of view, the gateway continuously polls the installation or devices, storing in its memory the values of the points that you previously configured to be read. With the change of value (COV) system, the gateway can also subscribe to configured BACnet points, automatically receiving their values when they change. On the other hand, from the Modbus point of view, the control and monitoring system reads and writes those stored points.

This is possible because, inside the gateway, all BACnet objects of the server devices are associated with Modbus registers. This makes the Modbus control and monitoring system perceive the BACnet installation (all the server devices) as if it were a single Modbus device.

When the gateway polls the BACnet devices, if a non-response is detected, the corresponding virtual signal inside the gateway will be activated, indicating the communication error to the Modbus system as error registers.

6. BACnet Client to ASCII

6.1. Specific Gateway Introduction

This section describes the integration of BACnet/IP and MS/TP devices into ASCII IP or Serial installations using the **BACnet client to ASCII** application.

This integration allows any ASCII system to access the signals and resources of BACnet devices as if they were part of the system itself and vice versa.

The gateway configuration is carried out through the configuration tool.

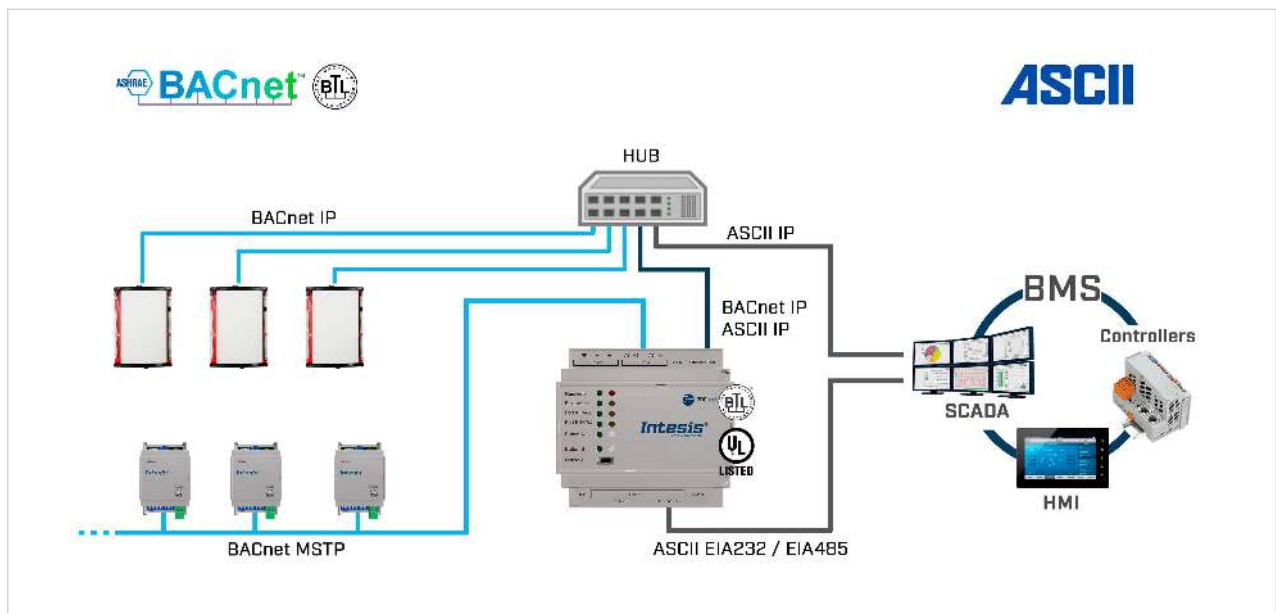

Figure 3. Integration of BACnet/IP or MS/TP devices into ASCII TCP/IP or Serial installations

6.2. Functionality

From the BACnet point of view, the gateway continuously polls the installation or devices, storing in its memory the values of the points that you previously configured to be read. On the other hand, from the ASCII point of view, the control and monitoring system reads and writes those stored points.

This is possible because, inside the gateway, all BACnet objects of the server devices are associated with ASCII objects. This makes the ASCII control and monitoring system perceive the BACnet installation (all the server devices) as if it were a single ASCII device.

When the gateway polls the BACnet devices, if a non-response is detected, the corresponding virtual signal inside the gateway will be activated, indicating the communication error to the ASCII system.

7. Gateway Capacity

Table 1. For Modbus master to BACnet server

Element	100 version	250 version	600 version	1200 version	3000 versions
Type of BACnet devices	Those supporting communication with BACnet/IP and MS/TP				
Maximum number of BACnet objects	100	250	600	1200	3000
Maximum number of BACnet Subscriptions (COV) requests	200	500	1200	2400	6000
Type of Modbus server devices	Those supporting communication over Modbus TCP/IP and RTU (EIA-485)				
Number of Modbus server devices supported by the device	Up to 5 Modbus TCP nodes/devices Up to 255 Modbus RTU devices per TCP/RTU node				

Table 2. For BACnet client to Modbus server

Element	100 version	250 version	600 version	1200 version	3000 version
Type of BACnet devices	Those supporting communication with BACnet/IP and MS/TP				
Maximum number of BACnet devices	256				
Maximum number of Modbus Registers	100	250	600	1200	3000
Modbus link layers supported	Those supporting communication over Modbus TCP/IP and RTU (EIA-485)				

Table 3. For BACnet client to ASCII

Element	100 version	250 version	600 version	1200 version	3000 version
Type of BACnet devices	Those supporting communication with BACnet/IP and MS/TP				
Maximum number of BACnet devices	256				
Maximum number of ASCII Registers	100	250	600	1200	3000
ASCII link layers supported	Those supporting communication with ASCII client with simple messages through a TCP/IP or serial (EIA-232/EIA-485) connection				

8. BACnet Interface

8.1. General Description

BACnet is a solid standard with many detailed concepts, but for this manual purposes, we will focus on the two most fundamental concepts:

- BACnet client, which is the device that sends service requests to the server.
- BACnet server, which is the device that performs the requested service and reports the result back to the client.

BACnet server devices are represented in the form of *devices* holding *objects*. Usually, every physical device corresponds to a logical one. The objects can be of different types depending on the data and functionality they represent: Analog input, Analog output, Digital input, etc.



NOTE

- Output objects are objects meant to be written in the direction BACnet network to the device.
- Input objects are meant to offer status information of the BACnet device.
- Value objects are bidirectional.

Every object has different properties. The most meaningful one is the **Present_Value** property, which indicates the real value of the object. Also, the gateway uses this property to read and write values. Every object of the same type in a device is identified with its associated **object instance**.

8.2. BACnet Client

8.2.1. Description

The gateway implements a single BACnet object of its own: its BACnet Device Object, which contains its BACnet Device Identifier and basic properties of the gateway as a BACnet device (name, firmware version, etc.).



NOTICE

When acting as a client device, the Intesis gateway is classified under the device profile of a BACnet Application Specific Controller (B-ASC). For further details, check out the product website for the BACnet client PIC statements.

The gateway emulates a client device in the BACnet system.

These are the possible BACnet objects supported by the Intesis gateway:

Object Type	Property	Description
Analog Input	Present Value	Analog signal, for example, Ambient temperature
Analog Output	Present Value	Analog signal
Analog Value	Present Value	Analog signal, for example, Temperature set point value
Binary Input	Present Value	Digital signal, for example, ON/OFF status
Binary Output	Present Value	Digital signal, for example, ON/OFF command
Binary Value	Present Value	Digital signal, for example, ON/OFF status/ command
Multistate Input	Present Value	Multistate signal, for example, Working mode status
Multistate Output	Present Value	Multistate signal
Multistate Value	Present Value	Multistate signal, for example, Working mode command
Accumulator	Present Value	
Loop	Present Value	

Every signal is identified with its associated Device + Object Type + Object Instance.



IMPORTANT

Though BACnet/IP and BACnet MS/TP physical layers are supported, only one physical layer can be used at a time, i.e., if communicating to BACnet using BACnet/IP, BACnet MS/TP cannot be used, and vice versa.





NOTE

Using the configuration tool, it's possible to scan the BACnet network for available devices and their objects, which can later be directly added to your configuration. This feature facilitates the configuration process, avoiding entering them manually.

8.2.2. Points Definition

Every point defined in the Intesis gateway has the following BACnet features associated with it:

Feature	Description
BACnet Device	<p>BACnet device to which the point belongs (a list of 256 BACnet devices can be defined in the Intesis gateway).</p> <p>For every BACnet device defined, a virtual signal is created automatically in the gateway to report the communication status with the BACnet device. Like the rest of the points, this signal is also available from the other protocol's interface.</p>
BACnet object type	<ul style="list-style-type: none"> • AI: Analog Input • AO: Analog Output • AV: Analog Value • DI: Digital Input • DO: Digital Output • DV: Digital Value • MI: Multistate Input • MO: Multistate Output • MV: Multistate Value • LOOP: Loop • ACUM: Accumulator <div style="background-color: #f0f0f0; padding: 5px; margin-top: 10px;">  <p>IMPORTANT Please read the documentation of the BACnet devices you're willing to integrate to know their object types.</p> </div>
BACnet object instance	<p>BACnet object instance for the point on the external BACnet device.</p> <div style="background-color: #f0f0f0; padding: 5px; margin-top: 10px;">  <p>IMPORTANT Please read the documentation of the BACnet devices you're willing to integrate to know their object types.</p> </div>

8.3. BACnet Server

8.3.1. Description



NOTICE

When the Intesis gateway acts as a server device, it is classified under the device profile of a BACnet Advanced Application Controller (B-AAC). For further details, check out the product website for the BACnet client PIC statements.

Using the configuration tool, you can configure the object type associated with the signal on the other protocol.

To facilitate the translation towards BACnet, the following object type options are available:

Object Type	ID
Analog-Input	0
Analog-Output	1
Analog-Value	2
Binary-Input	3
Binary-Output	4
Binary-Value	5
Calendar	6
Device	8
Multistate-Input	13
Multistate-Output	14
Multistate-Value	19
Notification-Class	15
Schedule	17
Trend-Log	20
Trend-Log-Multiple	27

Every signal of the Intesis gateway can have several objects. These objects and their properties can be configured with the configuration tool.

Depending on the field device protocol, you can define the signals using one of the following options:

- Configuring them manually for each or multiple signals at the time.
- Importing a file with the signals of the field devices.
- Scanning the network of the devices if this is supported.

Example 1. Signals compatibility

You can choose an object from the BACnet server column that is compatible with this signal. For example, a writable register in the Modbus device can be an output object type on the BACnet server side; a readable and writable register can be a value object type, etc.



NOTICE

The configuration tool provides default templates that make this signals assignment process easier. Also, you only have to click the **Check table** button on the bottom right corner of the window to know if everything is correct or if there's some mistake. The project is also automatically checked before you transfer it to the gateway.

All objects definition, BIBBs, and details about the implementation can be found on the BACnet server PICS on the product website.

8.3.2. BACnet/IP

The UDP communication port is the main setup parameter for BACnet IP, besides basic IP settings (IP, netmask, default gateway). The Intesis gateway uses the 47808 (0xBAC0) port by default, which you can change through the configuration tool.

When using BACnet/IP, the gateway can also act as a foreign device to communicate with devices in another network domain. Alternatively, you can set it as a BBMD (Bacnet/IP Broadcast Management Device). This functionality facilitates the communication of devices placed in other networks with the devices in the gateway network.



IMPORTANT

BACnet/IP and BACnet MS/TP communication can not be used simultaneously.

8.3.3. BACnet MS/TP

When you choose BACnet MS/TP (serial communication), you have to use the configuration tool to associate the gateway with a MAC address within the MS/TP network segment.

Baud rates supported for MS/TP line are: 9600, 19200, 38400, 76800, 115200, or Autobauding (autodetect).

Standard wiring guidelines for EIA-485 apply to the BACnet MS/TP line.



IMPORTANT

BACnet MS/TP and BACnet/IP communication can not be used simultaneously.

9. Modbus Interface

9.1. General Description

The Modbus protocol is an application-layer messaging protocol developed by Modicon in 1979. It is used to establish master-slave/client-server communication between intelligent devices over different types of buses or networks. The Intesis gateway supports Modbus TCP and RTU.

Modbus is a request/reply protocol and offers services specified by function codes. Modbus function codes are elements of Modbus request/reply PDUs (Protocol Data Unit).

9.2. Modbus Server Interface

9.2.1. Description

The gateway acts as a server device in its Modbus interface, which can be:

- The Ethernet port for Modbus TCP.
- The EIA-485/EIA-232 ports for Modbus RTU.



NOTICE

Modbus RTU and TCP modes can be active in the gateway one at a time or both simultaneously.

To access the gateway's points and resources from a Modbus client device, you must specify as Modbus register addresses those configured inside the gateway corresponding to the signals on the field device protocol.

9.2.2. Functions Supported



NOTICE

This part is common for both Modbus TCP and Modbus RTU.

Table 4. Modbus functions

#	Function	Read/Write
01	Read Coils	R
02	Read Discrete Inputs	R
03	Read Holding Registers	R
04	Read Input Registers	R
05	Write Single Coil	W
06	Write Single Register	W
15	Write Multiple Coils	W
16	Write Multiple Registers	W

If poll records are used to read or write more than one register, the range of addresses requested must contain valid addresses; if not, the Intesis gateway will return the corresponding Modbus error code.

All registers are of 2 bytes, even if they are associated with signals of bit type on the other protocol's side. Its content is expressed in MSB .. LSB.¹

Modbus error codes are fully supported. They are sent whenever a non-valid Modbus action or address is required.

¹MSB: most significant bit; LSB: less significant bit

9.2.3. Modbus RTU

Using the configuration tool, you can set these parameters:

- Baud rate: 1200, 2400, 4800, 9600, 19200, 38400, 56700 and 115200 bps.
- Data Bits: 8 bits.
- Parity: none, even, or odd.
- Stop Bits: 1 and 2 bits.
- Modbus server address.
- Physical connection (EIA-232 or EIA-485).



IMPORTANT

- EIA-232 connector uses RX, TX, and GND lines.
- EIA-485 connector uses B-, A+, and SNGD.

9.2.4. Modbus TCP

Modbus TCP communication is characterized basically by the embedding of the Modbus RTU protocol into TCP/IP frames, which allows faster communication and a longer distance between client and server devices in comparison with RTU communication over a serial line. Another benefit is using common TCP/IP infrastructure in buildings and transmitting over WAN or the internet. It also allows the coexistence of one or more clients and, of course, one or more server devices in a given network, all interconnected through a TCP/IP-based network.

Use the configuration tool to configure the IP settings of the gateway (DHCP status, own IP, netmask, and default gateway) and the TCP port.



NOTE

The default port is 502.

9.2.5. Modbus Server Interface Points Definition

The Modbus registers are fully configurable through the configuration tool; any point in the gateway can be freely configured with the desired Modbus register address.

Every point defined in the gateway has the following Modbus features associated with it:

Feature	Description
#Bits	<ul style="list-style-type: none"> • 1 bit • 16 bits • 32 bits
Data Coding Format	<ul style="list-style-type: none"> • 16/32 unsigned • 16/32 bits signed (one's complement – C1) • 16/32 bits signed (two's complement – C2) • 16/32 bits Float • 16/32 bits Bitfields • Error comm.
Byte Order	<ul style="list-style-type: none"> • Big Endian • Little Endian • Word Inverted Big Endian • Word Inverted Little Endian
Register Address	The Modbus register address inside the server device for the point.
Bit inside the register	<p>Bit inside the Modbus register (optional). The Intesis gateway allows bit decoding from generic 16 bits input/holding Modbus registers.</p> <p><i>Some devices use the bit coding into 16 bits input/holding Modbus registers to encode digital values. These registers are generally accessible using Modbus function codes 03 and 04 (read holding/input registers).</i></p>
Read/Write	<p>0: Read</p> <p>1: Write</p> <p>2: Trigger</p>

9.3. Modbus Client Interface

9.3.1. Description

The Intesis gateway acts as a client device in the Modbus TCP network, Modbus RTU client, or both.



IMPORTANT

Other Modbus devices connected to the network communicating with the gateway must always be server devices.

The gateway supports communication with up to five Modbus TCP server devices.

For every defined point belonging to a particular Modbus TCP server device, a server address from 0 to 255 can also be freely configured. This feature offers great flexibility for installations. For example, when integrating several Modbus RTU server devices connected in a serial line, with an RTU/TCP converter on top of this serial line, it enables access to the RTU server points through TCP/IP. In this case, the RTU/TCP converter communicating in TCP identifies the destination of the point (server address in the RTU network) by the contents of the server address field.

Modbus TCP server devices are characterized by their IP address and predefined registers address map. This address map specifies the address, type, and characteristics of the Modbus server device's internal points (commonly called registers). These registers are accessible using the Modbus TCP protocol.

Communication parameters of the Intesis gateway (IP address, netmask, default router address, and TCP port) are fully configurable to adapt to any IP network and server device.

The Modbus TCP protocol defines different function code types to read/write different register types from the Modbus devices. It also defines different data formats to encode values.

Also, the data encoding used for 16 bits registers (big-endian or little-endian) can be configured in the Intesis gateway. This is the byte order for data encoding (MSB..LSB or LSB..MSB)². Although specified as big-endian in the Modbus protocol specification, this data encoding varies depending on the manufacturer/type of server.

9.3.2. Points Definition

Every point defined in the Intesis gateway has the following Modbus features associated with it:

Feature	Description
Modbus device	Modbus TCP device to which belongs the point, from a list of Modbus TCP server devices that can be defined in the Intesis gateway (up to 5). For every defined Modbus TCP server device, a virtual signal is automatically created in the Intesis gateway to report the communication with the device. Like the rest of the points, this signal is also available from the field device interface.
Function code Read func. Write func.	01 Read Coils 02 Read Discrete Inputs 03 Read Holding Registers 04 Read Input Registers 05 Write Single Coil 15 Write Single Register 06 Write Multiple Coils 16 Write Multiple Register
#Bits	Number of bits to be used by this signal.
Data coding format	<ul style="list-style-type: none"> • 16/32/48/64 bits unsigned • 16/32/48/64 bits signed (one's complement – C1) • 16/32/48/64 bits signed (two's complement – C2) • 16/32/48/64 bits Float • 16/32/48/64 bits Bitfields • Error comm
Byte order	<ul style="list-style-type: none"> • Big-endian • Little-endian • Word inverted big-endian • Word inverted little-endian
Register address	The Modbus register address inside the server device for the point.
Bit inside the register	Bit inside the Modbus register (optional). The Intesis gateway allows bit decoding from generic 16 bits input/holding Modbus registers. <div style="background-color: #f0f0f0; padding: 5px; margin-top: 10px;">  NOTICE Some devices use the bit coding into 16 bit input/holding Modbus register to encode digital values. These registers are generally accessible using Modbus function codes 03 and 04 (read holding/input registers). </div>

²MSB: most significant bit; LSB: less significant bit

10. ASCII Interface

10.1. Description

The Intesis gateway can be connected to any ASCII-enabled device via its EIA-232, EIA-485, or TCP/IP (Ethernet) connectors, supervising and controlling its internal points through this interface by using simple ASCII messages.

When the gateway receives a new value for a point from the other protocol system, its ASCII interface sends the corresponding message indicating the new value to the ASCII system.



IMPORTANT

- This functionality is only possible if the point is configured to send these "spontaneous messages." If it doesn't, the new value will remain available in the gateway for a later poll of the ASCII system.
- You can configure this behavior for every gateway point through the configuration tool.

10.2. ASCII Serial

The ASCII interface and the ASCII master device serial connection type must be the same.

10.3. ASCII TCP

The Intesis gateway allows the configuration of:

- TCP port (5000 by default).
- IP address.
- Subnet mask.
- Default router address.

10.4. Address Map

The ASCII address map is fully configurable; any point in the gateway can be freely configured with the desired internal register address.

10.5. Points Definition

Every point defined in the gateway has the following ASCII features associated with it:

Feature	Description			
Signal	Signal or point description. Only for information purposes at the user level.			
ASCII string	Defines the ASCII string that will be used to access this register. Max. length: 32 characters			
Read/Write	Defines the current function (read, write, or both) to be used from the ASCII side with this register. It can't be configured as it is directly set when selecting the current BACnet type object.			
	Function	Read	Write	Read/Write
	BACnet object	Analog input Binary input Multistate input Loop Accumulator	Analog output Binary output Multistate output	Analog value Binary value Multistate value
Spontaneous	Determines the creation and sending of an ASCII message when any point from the BACnet side changes its value.			
A/D (Analog/ Digital)	Defines the current variable type for this register from the ASCII side. It can't be configured as it is directly set when selecting the current BACnet type object.			
	Type	Analog	Digital	
	BACnet object	Analog input Analog output Analog value Multistate input Multistate output Multistate value Loop Accumulator	Binary input Binary output Binary value	

10.6. Messages

The ASCII side communicates through simple ASCII messages.



NOTE

You can configure these messages to match the ASCII master device using the configuration tool.

The ASCII messages used to read/write points have the following format:

Message to read a point value:

ASCII_String?
ASCII_String?\r

Where:

- **ASCII_String** is the string indicating the point address inside the Intesis gateway.
- **?** is the character used to indicate that this is a reading message (configurable with Intesis MAPS).
- **\r** is the carriage return character (HEX 0x0D, DEC 13).

Message to write a point value:

ASCII_String=vv\r

Where:

- **ASCII_String** is the string indicating the point address inside the Intesis gateway.
- **=** is the character used to indicate that this is a reading message (configurable with Intesis MAPS).
- **vv** is the current point value.
- **\r** is the carriage return character (HEX 0x0D, DEC 13).

Message about a point value: sent spontaneously when the Intesis gateway receives a change from the BACnet side or in response to a previous poll for the point.

ASCII_String=vv\r

Where:

- **ASCII_String** is the string indicating the point address inside the Intesis gateway.
- **=** is the character used to indicate where the point data starts.
- **vv** is the current point value.
- **\r** is the carriage return character (HEX 0x0D, DEC 13).

11. Mounting



IMPORTANT

Before mounting, please ensure that the chosen installation place preserves the gateway from direct solar radiation, water, high relative humidity, or dust.



IMPORTANT

Ensure the gateway has sufficient clearances for all connections when mounted. See [Dimensions \(page 38\)](#).



NOTE

Mount the gateway over a DIN rail, preferably inside a grounded metallic industrial cabinet.

DIN rail mounting

The back panel has a groove to fit the gateway to the DIN rail using two static tabs (top side) and a mobile clip (bottom side).

1. Press the mobile clip until you hear a *click*.
2. Fasten the gateway to the DIN rail.
3. Press the clip again to lock the gateway to the rail.

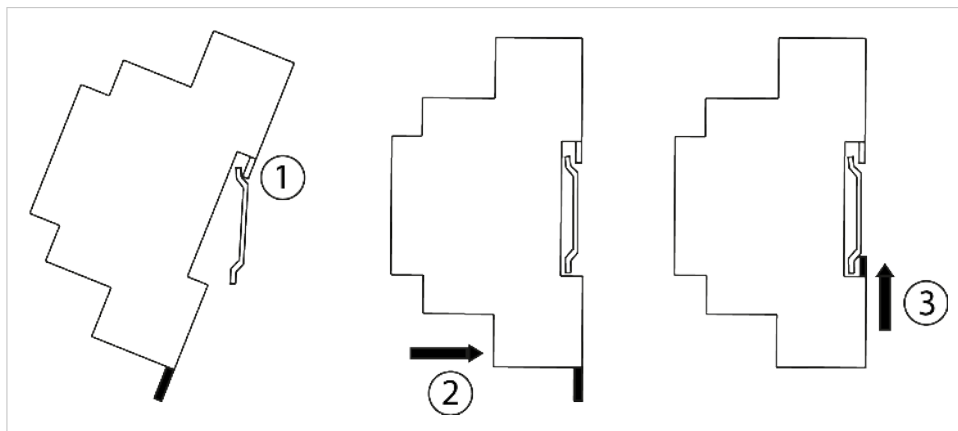

12. Connections

Please find in the following table the gateway's ports and their use depending on the configuration.

Configuration	Port A EIA-485	Port B EIA-485	Port B EIA-232	Ethernet
IN-BAC-MBM	Modbus RTU	Bacnet MS/TP, Modbus RTU	NA	Modbus TCP, BACnet/IP, and Console*
IN-MBS-BAC	BACnet MS/TP	Modbus RTU	Modbus RTU	Modbus TCP, BACnet/IP, and Console*
IN-ASCII-BAC	BACnet MS/TP	ASCII	ASCII	BACnet/IP, ASCII TCP, and Console*

*Console: you can use the Ethernet port to connect the gateway to the PC for configuration purposes.

The following table shows the pinout correspondence for each serial port.

Port A EIA-485	Port B EIA-485	Pin-out
A4	B1	A+
A3	B2	B-
A1 and A2	B3	SNGD

12.1. Power Supply



NOTE

The way to supply power to the gateway is the same for all applications.



CAUTION

Before manipulating any equipment, including this gateway, ensure the system is disconnected from the power source.

The power supply connector is a green pluggable terminal block (3 poles) labeled as **Power**.



IMPORTANT

- Use SELV-rated NEC class 2 or limited power source (LPS) power supply.
- Connect the gateway's ground terminal to the installation grounding.
- A wrong connection may cause earth loops that can damage the Intesis gateway and/or any other system equipment.

Apply the voltage within the admitted range and of enough power:

- **For DC:** 9 .. 36 VDC, Max: 260 mA
- **For AC:** 24 VAC (+/-10 %), 50-60 Hz, Max: 100 mA

Recommended voltage: 24 VDC, Max: 100 mA

**IMPORTANT**

- **When using a DC power supply:** Respect the polarity labeled on the power connector for the positive and negative wires.
- **When using an AC power supply:** Ensure the same power supply is not powering any other device.

Once connected, the Run LED of the gateway will turn on.

12.2. Connection Diagrams for each Application

Look for the appropriate diagram depending on your application:

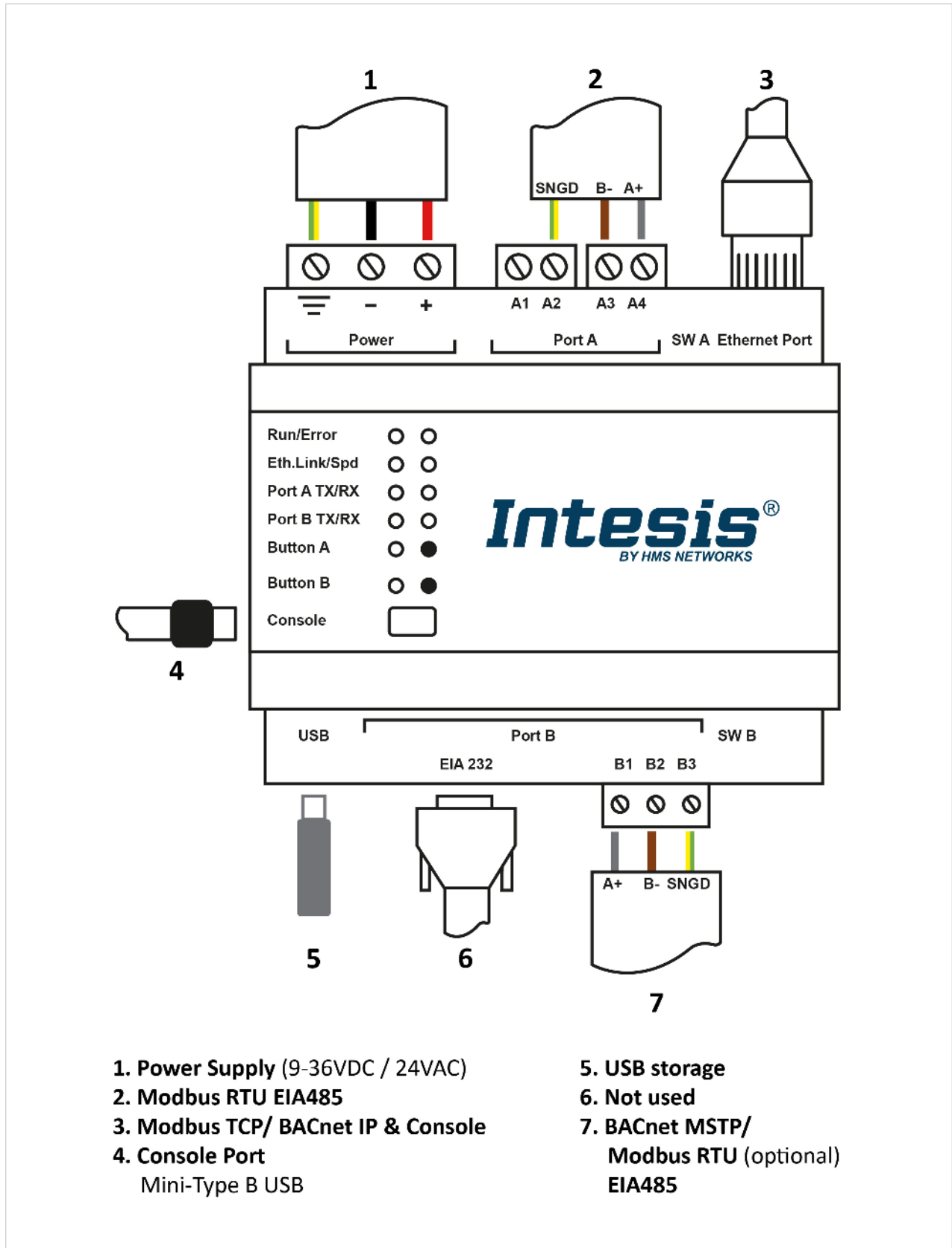

Figure 4. Modbus master to BACnet server

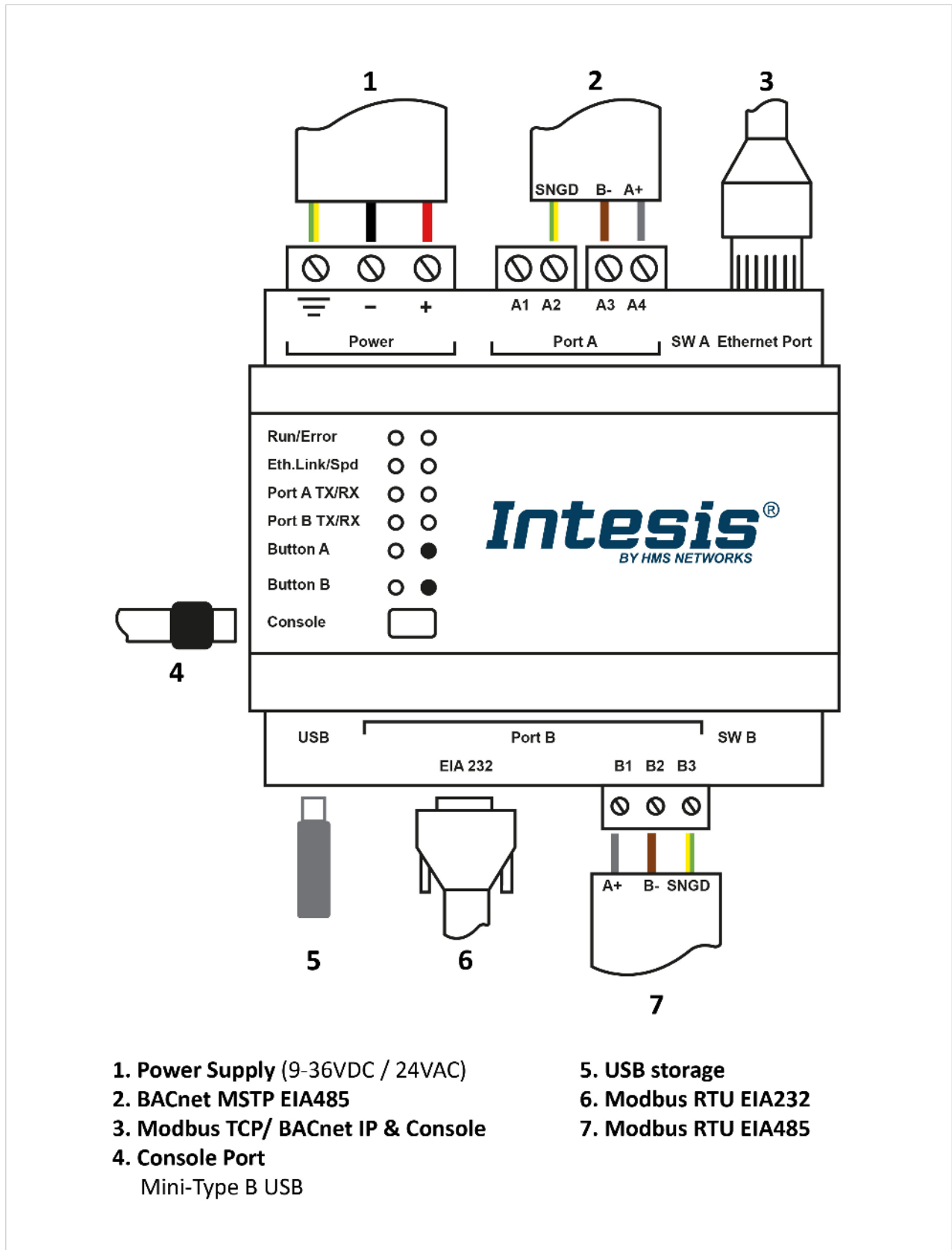

Figure 5. BACnet client to Modbus server

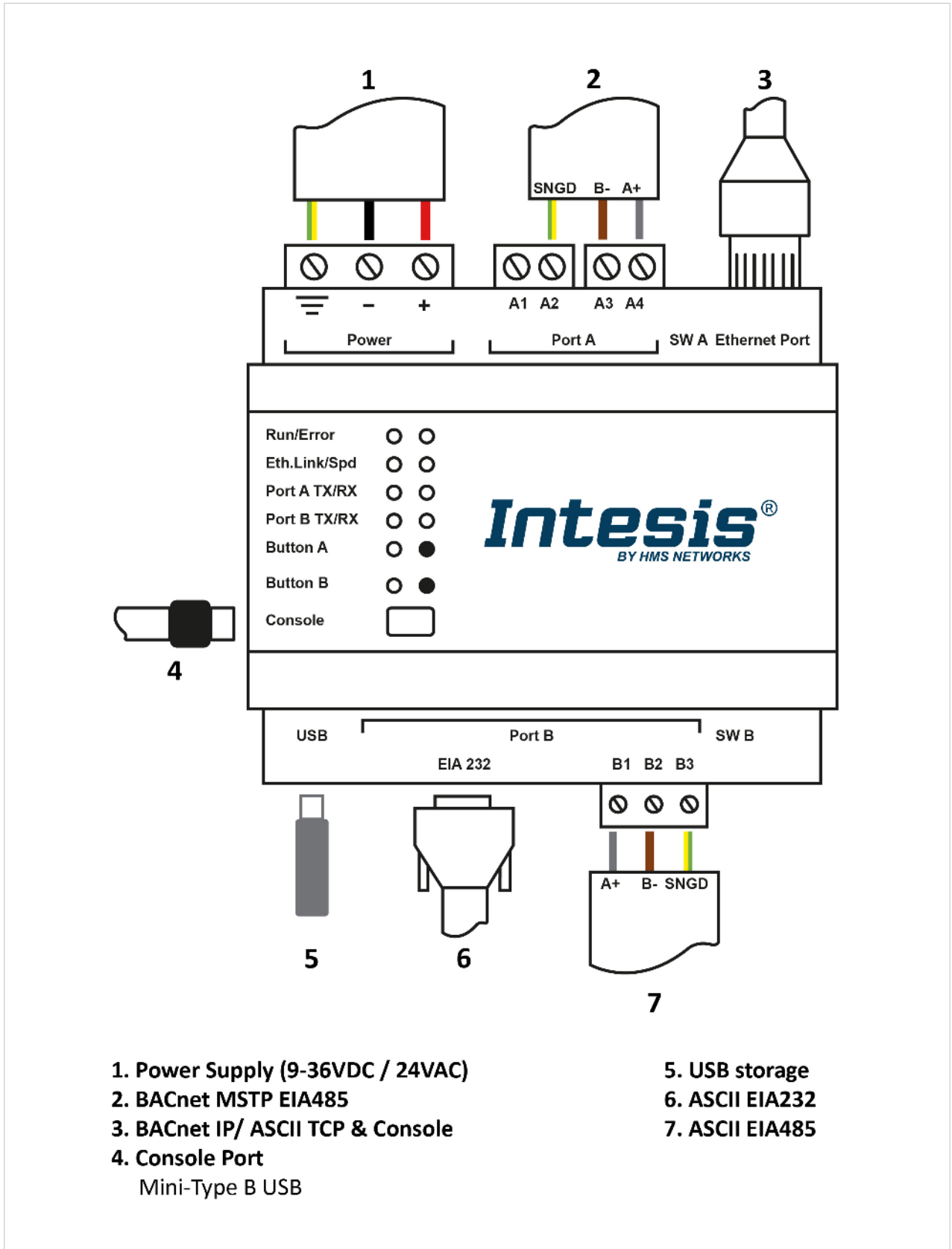

Figure 6. BACnet client to ASCII

12.3. Connection to Modbus

- **Ethernet port for Modbus TCP and Console connection:**

Connect the communication cable from the Modbus TCP network to the Ethernet port of the gateway.



IMPORTANT

Use a straight Ethernet UTP/FTP CAT5 or higher cable.



IMPORTANT

If communicating through the LAN of the building, contact the network administrator and make sure traffic on the used port is allowed through all LAN paths.



NOTE

After powering up the Intesis gateway for the first time, DHCP will be enabled for 30 seconds. After that time, if a DHCP server provides no IP, the default IP 192.168.100.246 will be set.

- **Port B EIA-485 connection for Modbus RTU:**

Connect the EIA-485 bus to connectors B1 (A+), B2 (B-), and B3 (SNGD) of the gateway's Port B.



IMPORTANT

Respect the polarity.



IMPORTANT

Remember the characteristics of the standard EIA-485 bus:

- Maximum distance of 1200 meters.
- Maximum of 32 devices connected to the bus.
- A termination resistor of 120 Ω is needed at each end of the bus. The gateway has an internal bus biasing circuit already incorporating the termination resistor. It can be enabled using the DIP switches:
 - **Position 1**
 - ON: 120 Ω termination active.
 - OFF: 120 Ω termination inactive.
 - **Position 2 and 3**
 - ON: Polarization active.
 - OFF: Polarization inactive.
- If the termination resistor is enabled and you install the gateway at one of the ends of the bus, do not install an additional termination resistor at that end.



NOTE

Only for the Modbus client to BACnet server application, you can also use **Port A** for the Modbus RTU connection (see [Figure 4 \(page 24\)](#)).

- **Port B EIA-232:**

Connect the serial cable EIA-232 from the external serial device to the EIA-232 connector of the gateway Port B.



NOTE

This is a DB9 male (DTE) connector that only uses the TX, RX, and GND.



IMPORTANT

Respect the maximum distance of 15 meters.

12.4. Connection to BACnet

- **Ethernet connection for BACnet/IP:**

Connect the BACnet/IP network to the Ethernet port of the gateway. The correct cable to use depends on where the gateway is connected:

- Connecting directly to a BACnet/IP device: use a crossover Ethernet UTP/FTP CAT5 or higher cable.
- Connecting to a hub or switch of the LAN of the building: use a straight Ethernet UTP/FTP CAT5 or higher cable.



IMPORTANT

If there is no response from the BACnet devices to the frames sent by the gateway:

- Check that they are operative and reachable from the network connection used by the gateway.
- Check the gateway Ethernet interface sending *Pings* to its IP address using a PC connected to the same Ethernet network.
- Contact the network admin to be sure there are no limitations regarding UDP communication or ports blocked.



IMPORTANT

If communicating through the LAN of the building, contact the network administrator and make sure traffic on the used port is allowed through all LAN paths.



NOTE

After powering up the Intesis gateway for the first time, DHCP will be enabled for 30 seconds. After that time, if a DHCP server provides no IP, the default IP 192.168.100.246 will be set.

- **Port B EIA-485 connection for BACnet MS/TP:**

Connect the EIA-485 bus to connectors B1 (A+), B2 (B-), and B3 (SNGD) to the Port B of the gateway.



IMPORTANT

Respect the polarity.



IMPORTANT

Remember the characteristics of the standard EIA-485 bus:

- Maximum distance of 1200 meters.
- Maximum of 32 devices connected to the bus.
- A termination resistor of 120 Ω is needed at each end of the bus. The gateway has an internal bus biasing circuit already incorporating the termination resistor. It can be enabled using the DIP switches:
 - **Position 1:**
 - ON: 120 Ω termination active.
 - OFF: 120 Ω termination inactive.
 - **Position 2 and 3:**
 - ON: Polarization active.
 - OFF: Polarization inactive.



IMPORTANT

If the termination resistor is enabled and you install the gateway at one of the ends of the bus, do not install an additional termination resistor at that end.

12.5. Connection to ASCII

- **Ethernet port for ASCII TCP:**

Connect the communication cable from the ASCII TCP network to the Ethernet port of the gateway.

**IMPORTANT**

Use a straight Ethernet UTP/FTP CAT5 or higher cable.

**IMPORTANT**

If communicating through the LAN of the building, contact the network administrator and make sure traffic on the used port is allowed through all LAN paths.

**NOTE**

After powering up the Intesis gateway for the first time, DHCP will be enabled for 30 seconds. After that time, if a DHCP server provides no IP, the default IP 192.168.100.246 will be set.

- **Port B EIA-485 connection for ASCII serial:**

Connect the EIA-485 bus to connectors B1 (A+), B2 (B-), and B3 (SNGD) to the Port B of the gateway.

**IMPORTANT**

Respect the polarity.

**IMPORTANT**

Remember the characteristics of the standard EIA-485 bus:

- Maximum distance of 1200 meters.
- Maximum of 32 devices connected to the bus.
- A termination resistor of 120 Ω is needed at each end of the bus. The gateway has an internal bus biasing circuit already incorporating the termination resistor. It can be enabled using the DIP switches:
 - **Position 1:**
 - ON: 120 Ω termination active.
 - OFF: 120 Ω termination inactive.
 - **Position 2 and 3:**
 - ON: Polarization active.
 - OFF: Polarization inactive.
- If the termination resistor is enabled and you install the gateway at one of the ends of the bus, do not install an additional termination resistor at that end.

- **Port B EIA-232 for ASCII serial:**

Connect the serial cable EIA-232 from the external serial device to the EIA-232 connector of the gateway Port B.

**NOTE**

This is a DB9 male (DTE) connector that only uses the TX, RX, and GND.

**IMPORTANT**

Respect the maximum distance of 15 meters.

12.6. Console and USB Connections

- **Console port:**

Connect a USB Mini-B type cable from the gateway console port to a computer running the configuration tool.

**NOTICE**

With this software tool, you can configure and monitor the gateway.

**NOTE**

If your computer has an Ethernet port, you can also use the **Ethernet** port of the gateway to connect both.

- **USB port:**

**TIP**

You can connect a USB storage device to the USB port of the gateway to store logs.

**IMPORTANT**

The USB port doesn't support HDD devices.

13. Set-up Process with the Configuration Tool

13.1. Prerequisites

For this integration, you need:

- The items delivered by HMS Networks:
 - The Intesis IN700485xxx0000 protocol translator gateway.
 - A mini-type B USB to USB cable.
 - Link to download the configuration tool.
 - Product documentation.
- The respective client or server devices connected to either the EIA-485/EIA-232 Port B or to the Ethernet port.

13.2. Intesis MAPS: Configuration and Monitoring Tool

13.2.1. Introduction

To configure the gateway, you need a PC running Intesis MAPS. You can download this configuration tool from <https://www.intesis.com/products/intesis-maps#download>.

Intesis MAPS is a Windows® compatible software explicitly developed to monitor and configure Intesis gateways.



NOTE

The following sections provide some primary and general information to configure this gateway. Although Intesis MAPS is an easy-to-manage user-friendly tool, you may need more specific and comprehensive information about the different parameters and how to configure them. If so, please refer to these specific Intesis MAPS user manuals depending on the protocol you are working with:

- [BACnet](#)
- [Modbus](#)



NOTICE

The Intesis MAPS user manual referring to ASCII protocol will come soon.

13.2.2. Template Selection

When opening the software, you will see the main window, called **Getting started**. Here you can select the template for your application:

1. Click **Create New Project** in the left menu.
2. Select the appropriate template for your application. To filter the selection:
 - Click on the protocol logos.
 - Type the order code in the **Order Code** field,
 - Check out the list to find the template you need.

New Project

Select BMS Protocol

Select Template

Order Code:

Project Name	BMS Protocol	Device Protocol	Description	Gateway Order Code
IN-KNX-BAC	KNX	BACnet Client	Intesis BACnet Client to KNX Gateway	IN778AIBACxxx0000 INKNXBACxxxv000 IBKNXBACxxxv000
IN-KNX-DALI-64	KNX	DALI	Intesis DALI to KNX Gateway	INKNXDAL064v000 IBKNXDAL064v000
IN-KNX-FJ	KNX	Fujitsu VRF	Intesis Fujitsu AC to KNX Gateway	INKNXFGLxxx0v000 IBKNXFGLxxx0v000
IN-KNX-HI	KNX	Hitachi	Intesis Hitachi AC to KNX Gateway	IN778AIRxxx0000 INKNXHITxxx0v000 IBKNXHITxxx0v000
IN-KNX-HS	KNX	Hisense	Intesis Hisense AC to KNX Gateway	IN778AIRxxx0000 INKNXHISxxx0v000 IBKNXHISxxx0v000
IN-KNX-LG	KNX	LG	Intesis LG AC to KNX Gateway	INKNXLGExxx0v000
IN-KNX-MBM	KNX	Modbus Master	Intesis Modbus Master to KNX Gateway	IN781KIBxxx0000 INKNXMBNxxxv000 IBKNXMBNxxxv000
IN-KNX-MBUS	KNX	M-Bus	Intesis M-Bus to KNX Gateway	INKNXMBxxxv000 IBKNXMBxxxv000
IN-KNX-MD	KNX	Midea	Intesis Midea to KNX Gateway	IN778AIRxxx0000
IN-KNX-ME	KNX	Mitsubishi Electric	Intesis Mitsubishi Electric AC to KNX Gate...	IN778AIRxxx0000 INKNXMETxxx0v000 IBKNXMETxxx0v000
IN-KNX-MH	KNX	Mitsubishi Heavy Industries	Intesis Mitsubishi Heavy Industries to KNX...	IN778AIRxxx0000
IN-KNX-PA	KNX	Panasonic	Intesis Panasonic to KNX Gateway	IN778AIRxxx0000 INKNXPANxxx0v000 IBKNXPANxxx0v000
IN-KNX-SM	KNX	Samsung NASA	Intesis Samsung NASA AC to KNX Gateway	IN778AIRxxx0000 INKNXSANxxx0v000 IBKNXSANxxx0v000

Device model: 700 Series Family

Available Licenses

- 100 points
- 250 points
- 600 points
- 1200 points
- 3000 points

Order Codes

- IN701KNX1000000
- IN701KNX2500000
- IN701KNX6000000
- IN701KNX1K20000
- IN701KNX3K00000

Figure 7. The three possibilities for the template selection

3. Select the template and click **Next** or double-click it in the list.

13.2.3. Connection Tab

1. On the **Connection Type** parameter, select the way you connected the gateway to your PC:
 - Select **IP** if you are using the **Ethernet port** of the Intesis gateway.

**IMPORTANT**

Make sure you have an internet connection.

**NOTE**

When using the IP connection, the gateway's name appears:

- **In black:** It is compatible with the selected template.
- **In red:** It is not compatible with the selected template.

- Select **USB Port** if you are using the **Console port** of the gateway.
2. Select your gateway from the **Discovered Gateways** list on the left.
 3. Click **Connect**.

**NOTE**

If your Intesis gateway firmware doesn't match the selected template, a pop-up window will prompt you to download the correct firmware.

13.2.4. Configuration Tab

In the Configuration tab, you can configure general parameters and parameters for both protocol interfaces of the Intesis gateway.

On the left side of the window, three submenus are shown:

- Submenu 1: **General** configuration parameters for the gateway.
- Submenus 2 and 3: BMS and Device respective protocols configuration parameters.

13.2.5. Signals Tab

This menu lists all available signals and their parameters for both protocols.



NOTE

You can find more information on every parameter and how to configure it in the Intesis MAPS user manual:

- [Modbus](#)
- [BACnet](#)

Regardless of the protocol, all signals share some common characteristics and parameters:

Signals background color meaning:

Below the list of signals, these options are available:

- **Active signals:** Number of active signals in the list.
- **Hide Disabled signals:** Check this option to hide all disabled signals from the list.
- **Edit Columns:** Click this button to hide/show any column of the list.
- **Export:** Click this button to export the current signals' configuration to an xls file.
- **A:** Increases or decreases the font size.
- **Check table:** Click this button to check the signals' configuration. If any parameter on any signal is wrong, a message will pop up with specific information about the error.

13.2.6. Receive/Send Tab

Send:

Once you have finished setting the parameters, you have to send the configuration to the gateway.

Follow these steps:

1. Click the **Send** button.
 - a. If the gateway is still factory-set, you will be prompted to save the project on your PC. Once you save it, the configuration is automatically sent to the gateway.
 - b. If you have already saved the project, the configuration is automatically sent to the gateway.
2. Connect again with the gateway after sending the file.



NOTICE

The gateway will reboot automatically once the new configuration is loaded. This process may take a few seconds.

Receive:

Use this function to get the configuration of a gateway, for example, when you need to change some parameters of a gateway already mounted in an installation.

Once the configuration is completed and sent, the gateway is already operative. Even so, you should check that everything is working correctly by entering the Diagnostic tab.

13.2.7. Diagnostic Tab

IMPORTANT
 Connection with the gateway is required to use the diagnostic tools.

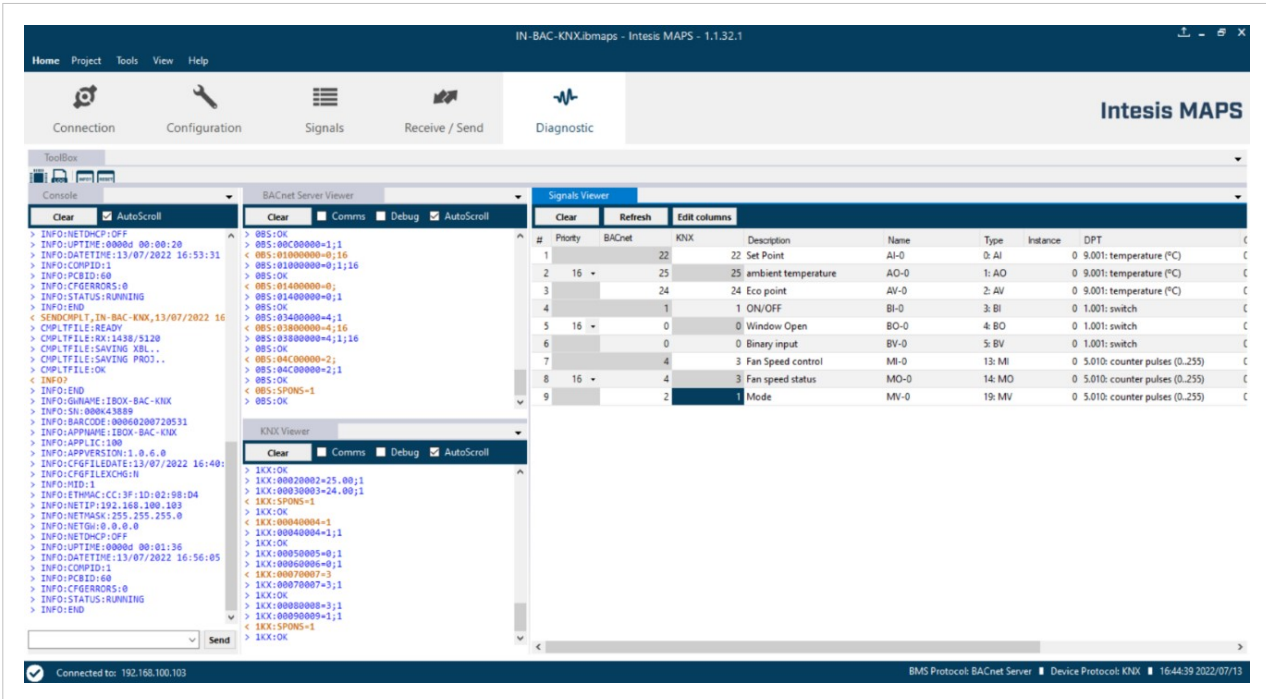
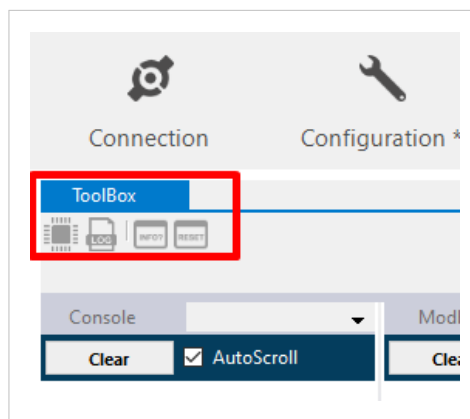

Figure 8. Diagnostic tab window. Find the ToolBox between the upper tabs bar and the Console view. Below it, from left to right: Console viewer, Protocol viewers (one above the other), and the Signals viewer

ToolBox:



Use the tools section to:

- **Microprocessor icon:** Check the current hardware status of the gateway.
- **LOG:** Set Intesis MAPS in logging mode to record all the information present in the viewers and save it in a .zip file.
- **INFO?:** Get some gateway information.
- **RESET:** Reset the gateway.

**NOTE**

Depending on your screen resolution, the **ToolBox** icons may appear partially hidden behind the **Viewers** window.

Viewers:

Intesis MAPS provides several viewers:

- A generic console viewer for general information about communications and the gateway status.
- A viewer for both protocols to check their current status.
- A signals viewers to simulate the BMS behavior or check the system's current values.

14. Technical Specifications

Enclosure	Plastic, type PC (UL 94 V-0) / Color: light grey. RAL 7035
Mounting	DIN rail EN60715 TH35
Terminal blocks wiring	Solid wires or stranded wires (twisted or with ferrule) are allowed. Per terminal: Millimeters: One core: 0.5 .. 2.5 mm ² / Two cores: 0.5 .. 1.5 mm ² / Three cores: not allowed Gauge: One core: 24 .. 11 AWG / Two cores: 24 .. 15 AWG / Three cores: not allowed
Power	1 x green pluggable terminal block (3 poles) Ground, negative, and positive <ul style="list-style-type: none"> • For DC: 9 to 36 VDC, Max: 260 mA • For AC: 24 VAC +/-10 %, 50-60 Hz, Max: 100 mA Recommended: 24 VDC, Max: 100 mA
Ethernet	1 x Ethernet RJ45 10/100BASE-T
Port A	1 x serial EIA-485 orange pluggable terminal block (2 poles) <ul style="list-style-type: none"> • A+, B- 1 x green pluggable terminal block (2 poles) <ul style="list-style-type: none"> • SGND (reference ground or shield) 1500 Vdc isolation from other ports
SW A	1 x DIP switch (3 position) for serial EIA-485 configuration: Position 1: <ul style="list-style-type: none"> • ON: 120 Ω termination active • OFF: 120 Ω termination inactive Position 2 and 3 <ul style="list-style-type: none"> • ON: polarization active • OFF: polarization inactive (default)
Port B	1 x serial EIA-232 DB9 male Pinout from a DTE device / 1500 VDC isolation from other ports (except Port B: EIA-485) 1 x serial EIA-485 green pluggable terminal block (3 poles) <ul style="list-style-type: none"> • A+, B-, SGND (reference ground or shield) 1500 VDC isolation from other ports (except Port B: EIA-232)
SW B	1 x DIP switch (3 position) for serial EIA-485 configuration: Position 1: <ul style="list-style-type: none"> • ON: 120 Ω termination active • OFF: 120 Ω termination inactive Position 2 and 3: <ul style="list-style-type: none"> • ON: polarization active • OFF: polarization inactive (default)
Battery	Type: Manganese Dioxide Lithium button battery / Size: 20 mm x 3.2 mm (0.79" x 0.13") / Capacity 3 V - 255 mA
Console port	USB Mini-B type 2.0 compliant / 1500 VDC isolation
USB port	USB A type 2.0 compliant / Only for USB flash storage devices (USB pen drive) / HDD connection not allowed / Power consumption limited to 150 mA
Push buttons	A and B buttons: Factory reset
Operational conditions	Temperature: 0 .. +60°C / Humidity: 5 .. 95% (no condensation)
LED indicators	10 x Onboard LED indicators: 1 x Power / 1 x Error / 2 x Ethernet / 2 x Port A / 2 x Port B / 1 x Button A / 1 x Button B

15. Dimensions

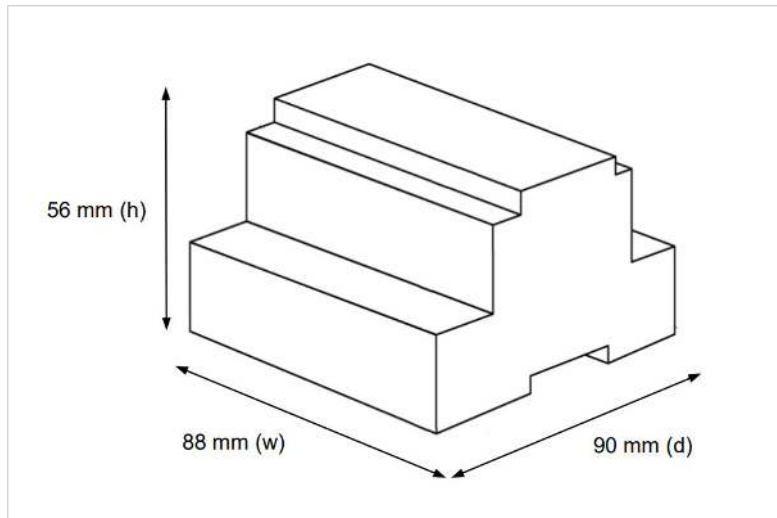

Figure 9. Gateway dimensions

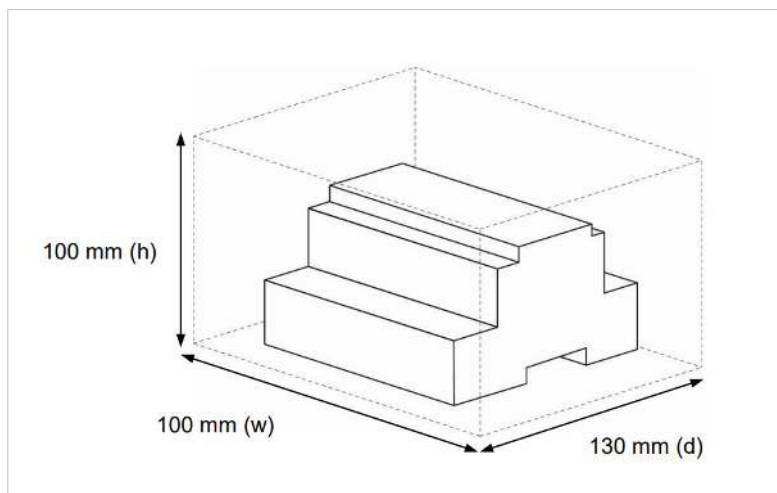

Figure 10. Space needed for connections