

REVISIONS					
P	LTR	DESCRIPTION	DATE	DWN	APVD
C4		REVISED PER ECN-22-156403	06JUN2022	RK	CSD

AMP WIRE RANGE	Listed FILE E13288	LR7189 Certified
16-14 AWG SOLID OR STRANDED	16-14 AWG SOLID OR STRANDED	16-14 AWG SOLID OR STRANDED

- ① STAMP AMP 16-14* APPROX AS SHOWN
- ② COPPER PER ASTM B-152, ANNEALED
- ③ TIN PLATE 0.00254 [.000100] MIN THK PER ASTM B-545
- ④ MEETS M7928/7-8, CLASS 1
- 5 NOTE DELETED
- 6 RECOMMENDED OPERATING TEM IS 170°C MAX
- 7 WIRE CROSS SECTIONAL AREA RANGE IS 1.04-2,62mm² [2,050-5,180] CMA

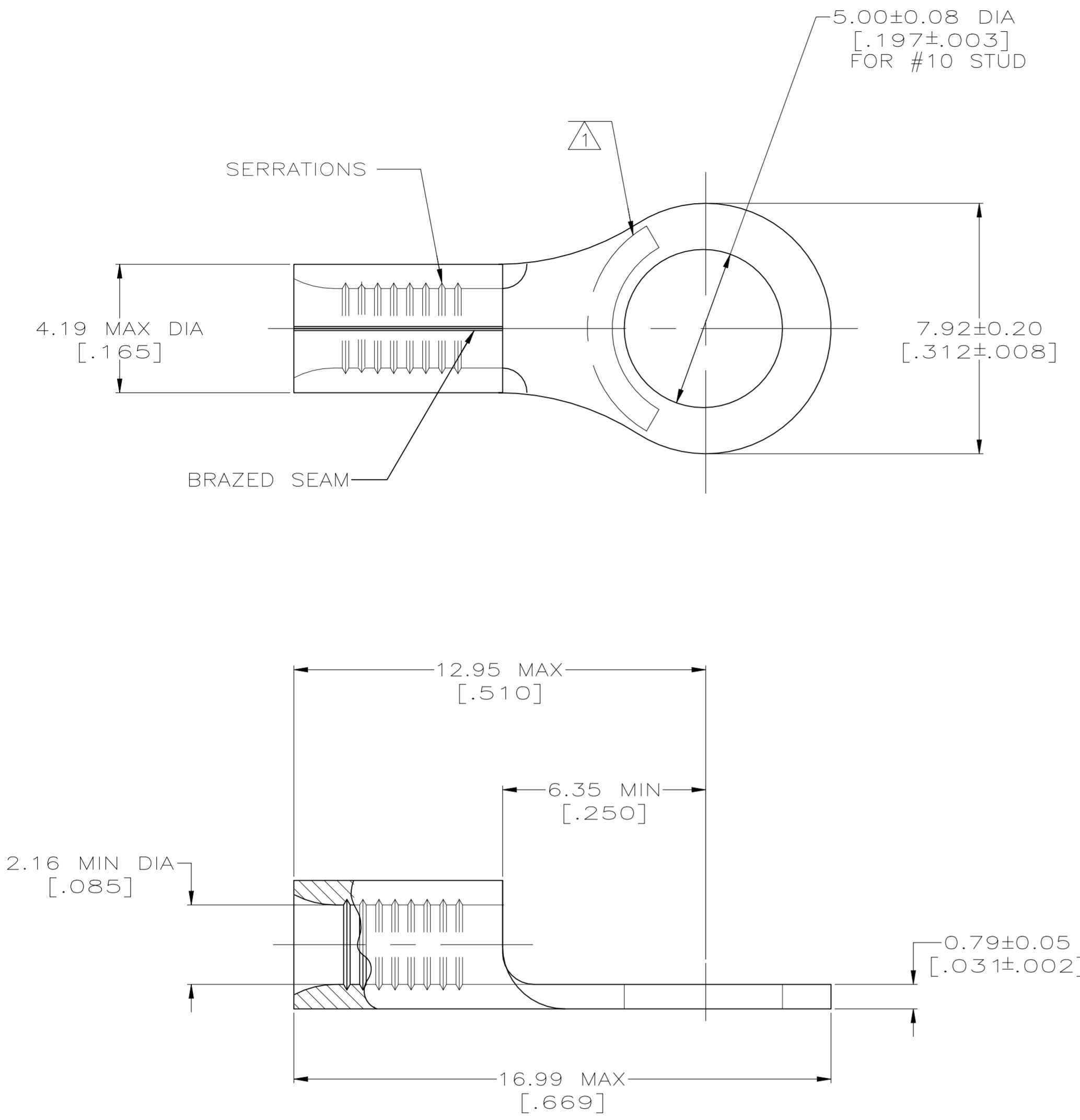

5000	ON TAPE	2-320093-1
----	LOOSE PIECE	④ 320093
QUANTITY	PACKAGING TYPE	PART NO.

THIS DRAWING IS A CONTROLLED DOCUMENT.		DWN TA BRINKMAN 3-17-93	TE Connectivity	
DIMENSIONS: mm[INCHES]		CHK DA PATTERSON 3-17-93		
TOLERANCES UNLESS OTHERWISE SPECIFIED:		APVD JL MECKLEY 3-17-93	NAME TERMINAL, RING TONGUE, SOLISTRAND	
0 PLC ± -		PRODUCT SPEC	SIZE A2	
1 PLC ± -		APPLICATION SPEC	CAGE CODE 00779	DRAWING NO C=320093
2 PLC ± -		WEIGHT	RESTRICTED TO	
3 PLC ± -		FINISH	SCALE 8:1	
4 PLC ± -			SHEET 1 OF 1	
ANGLES ± -			REV C4	
MATERIAL		CUSTOMER DRAWING		