

## Description

The AL5811 is a Linear LED driver with an adjustable LED current up to 75mA offering excellent temperature stability and output handling capability. The AL5811 simplifies the design of linear and isolated or non-isolated LED drivers by setting the LED current with standard value resistors.

The AL5811 has an open drain output that can swing from 1V up to 60V enabling it drive long LED chains. Its low 0.5V  $R_{SET}$  pin is outside of the LED current path and so accuracy is maintained while minimizing the required overhead to regulate the LED current. This reduces its power dissipation when compared to traditional linear LED drivers. This makes it ideal for driving LEDs up to 75mA.

Longer LED chains can be driven by tapping  $V_{CC}$  from the chain, where the chain voltage may exceed 60V.

The AL5811 is available in the exposed pad MSOP-8EP and U-DFN3030-6 packages.

## Pin Assignments

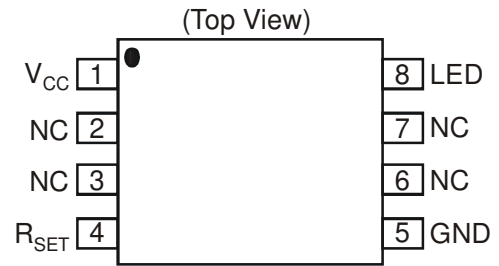

MSOP-8EP

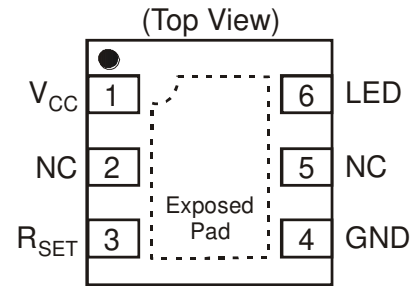

U-DFN3030-6

## Features

- Low Reference Voltage ( $V_{RSET} = 0.5V$ )
- $-40^{\circ}C$  to  $+125^{\circ}C$  Temperature Range
- $\pm 6\%$  Typical LED Current Tolerance
- Low Temperature Drift
- 1.0V to 60V Open-Drain Output
- High Power Supply Rejection
- MSOP-8EP and U-DFN3030-6
- **Totally Lead-Free & Fully RoHS Compliant (Notes 1 & 2)**
- **Halogen and Antimony Free. "Green" Device (Note 3)**

- Notes:
1. No purposely added lead. Fully EU Directive 2002/95/EC (RoHS) & 2011/65/EU (RoHS 2) compliant.
  2. See [http://www.diodes.com/quality/lead\\_free.html](http://www.diodes.com/quality/lead_free.html) for more information about Diodes Incorporated's definitions of Halogen- and Antimony-free, "Green" and Lead-free.
  3. Halogen- and Antimony-free "Green" products are defined as those which contain <900ppm bromine, <900ppm chlorine (<1500ppm total Br + Cl) and <1000ppm antimony compounds.

## Applications

- Isolated Offline LED Converters
- Linear LED Driver
- LED Signs
- Instrumentation Illumination

## Typical Applications Circuit

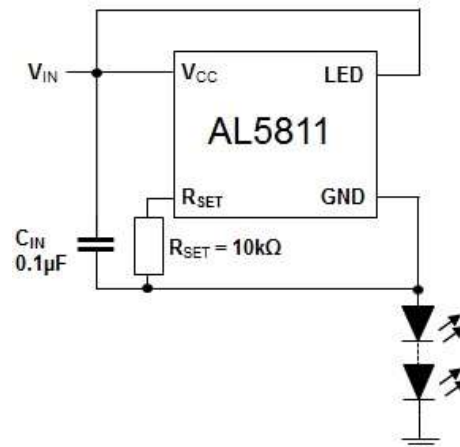
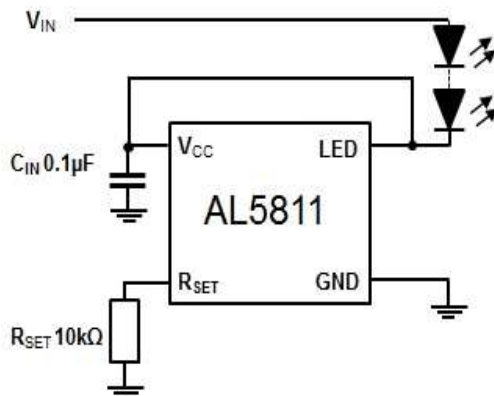

## Pin Descriptions

Pin Name	Pin Number		Function
	MSOP-8EP	U-DFN3030-6	
V <sub>CC</sub>	1	1	Supply Input. Connect a 0.1µF ceramic capacitor between V <sub>CC</sub> and GND as close as possible to the device.
R <sub>SET</sub>	4	3	LED Current Setting Pin. Connect a resistor from this pin to GND: $I_{LED} = 750/R_{SET}$ May also be used to provide PWM dimming functionality
GND	5	4	Ground Reference Point of Device.
LED	8	6	LED Current Sink Connection.
NC	2, 3, 6, 7	2, 5	Unused
EP	Exposed Pad	Exposed Pad	Exposed Pad (bottom). Used to improve thermal impedance of package. It must be connected to GND directly underneath the package.

## Functional Block Diagram

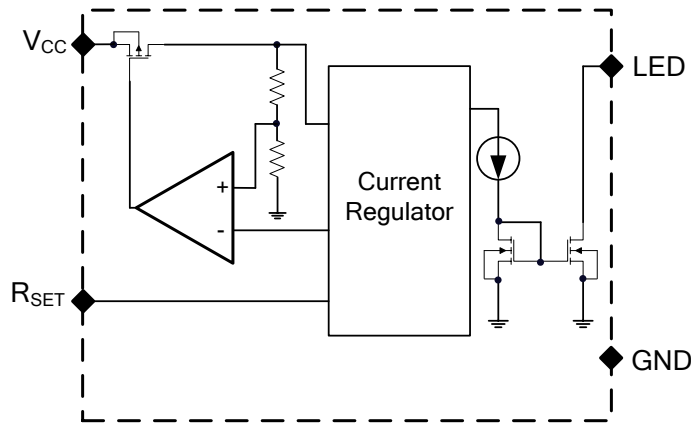

## Absolute Maximum Ratings (@T<sub>A</sub> = +25°C, unless otherwise specified.)

Symbol	Parameters	Ratings	Unit
V <sub>CC</sub>	Supply Voltage Relative to GND Pin (Note 4)	-0.3 to +66	V
V <sub>LED</sub>	LED Voltage Relative to GND Pin (Note 4)	-0.3 to +66	V
V <sub>RSET</sub>	R <sub>SET</sub> Voltage Relative to GND Pin	-0.3 to +6	V
I <sub>LED</sub>	LED Pin Current Sink Current Range	85	mA
ESD HBM	ESD Protection - Human Body Model	1	kV
ESD CDM	ESD Protection - Charged Device Model	1.2	kV
T <sub>J</sub>	Operating Junction Temperature	-40 to +150	°C
T <sub>ST</sub>	Storage Temperature	-55 to +150	°C

Notes: 4. V<sub>CC</sub> pin can be greater or smaller than V<sub>LED</sub>; neither should go below GND.

Caution: Stresses greater than the 'Absolute Maximum Ratings' specified above, may cause permanent damage to the device. These are stress ratings only; functional operation of the device at these or any other conditions exceeding those indicated in this specification is not implied. Device reliability may be affected by exposure to absolute maximum rating conditions for extended periods of time. Semiconductor devices are ESD sensitive and may be damaged by exposure to ESD events. Suitable ESD precautions should be taken when handling and transporting these devices

## Package Thermal Data

Package	$\theta_{JC}$ Thermal Resistance Junction-to-Case (Note 5)	$\theta_{JA}$ Thermal Resistance Junction-to-Ambient (Note 5)	$P_{Dis}$ $T_A = +25^\circ\text{C}$ , $T_J = +125^\circ\text{C}$
MSOP-8EP	37	85°C/W (Note 6)	1.2W
U-DFN3030-6	13	71°C/W (Note 7)	1.40W

- Notes:
5. Dominant conduction path via exposed pad.
  6. Test condition for MSOP-8EP: Device mounted on FR-4 PCB (51mm x 51mm 2oz copper, minimum recommended pad layout on top layer and thermal vias to bottom layer ground plane. For better thermal performance, larger copper pad for heat-sink is needed.
  7. Test condition for U-DFN3030-6: Device mounted on FR-4 PCB (51mm x 51mm 2oz copper, minimum recommended pad layout on top layer and thermal vias to bottom layer with maximum area ground plane. For better thermal performance, larger copper pad for heat-sink is needed.

## Recommended Operating Conditions (@ $T_A = +25^\circ\text{C}$ , unless otherwise specified.)

Symbol	Parameter	Min	Max	Unit
$V_{CC}$	Supply Voltage Range Relative to GND Pin	2.0	60	V
$V_{LED}$	OUT Voltage Range Relative to GND Pin	1.0	60	
$I_{LED}$	LED Pin Current (Notes 8 & 9)	10	75	mA
$T_A$	Operating Ambient Temperature Range	-40	+125	°C

- Notes:
8. Maximum LED current is also limited by ambient temperature and power dissipation such that junction temperature should be kept less than or equal +125°C.
  9. For  $V_{CC} < 3.5\text{V}$ , Maximum LED current is 50mA.

## Electrical Characteristics (@ $T_A = +25^\circ\text{C}$ , $V_{CC} = 2.0\text{V}$ , $V_{LED} = 1.0$ , $R_{SET} = 15\text{k}\Omega$ , unless otherwise specified.) (Note 10)

Symbol	Parameter	Conditions	Min	Typ	Max	Unit	
$V_{RSET}$	$R_{SET}$ Voltage	— $T_A = -40^\circ\text{C}$ to $+125^\circ\text{C}$	—	0.5	—	V	
$I_{LED}$	$I_{LED}$ Current Accuracy	$R_{SET} = 82.5\text{k}\Omega$	$T_A = +25^\circ\text{C}$	7.9	9	10.1	mA
		$R_{SET} = 37.5\text{k}\Omega$		18	20	22	
		$R_{SET} = 10\text{k}\Omega$ , $V_{CC} = 3.5\text{V}$		70	75	80	
		$R_{SET} = 15\text{k}\Omega$	$T_A = -40^\circ\text{C}$ to $+125^\circ\text{C}$	46	50	54	
		$R_{SET} = 82.5\text{k}\Omega$	$T_A = -40^\circ\text{C}$ to $+125^\circ\text{C}$	7.65	9	10.35	
		$R_{SET} = 15\text{k}\Omega$	$V_{CC} = 2.0\text{V}$ to $3.5\text{V}$	43	50	58	
REGLINE	LED Current Line Regulation	$V_{CC} = 3.5\text{V}$ to $60\text{V}$	$T_A = +25^\circ\text{C}$	—	0.25	—	%
$I_{CC}$	Supply Current	$2.0\text{V} \leq V_{CC} \leq 60\text{V}$	$T_A = +25^\circ\text{C}$	—	200	300	$\mu\text{A}$
			$T_A = -40^\circ\text{C}$ to $+125^\circ\text{C}$	—	—	350	
$I_{LEAK}$	LED Pin Leakage Current	$V_{CC} = 60\text{V}$ ; $V_{LED} = 60\text{V}$ $R_{SET} = \text{Open Circuit}$	$T_A = +125^\circ\text{C}$	—	—	1	$\mu\text{A}$
$T_{SHDN}$	Thermal Shutdown	—	—	—	+155	—	°C
$T_{HYS}$	Thermal Shutdown Hysteresis	—	—	—	+20	—	°C

- Note: 10. All voltages unless otherwise stated are measured with respect to GND pin.

**Typical Performance Characteristics**

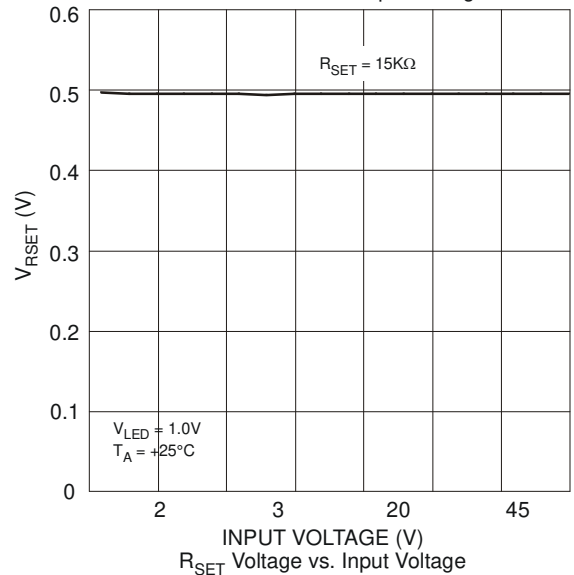
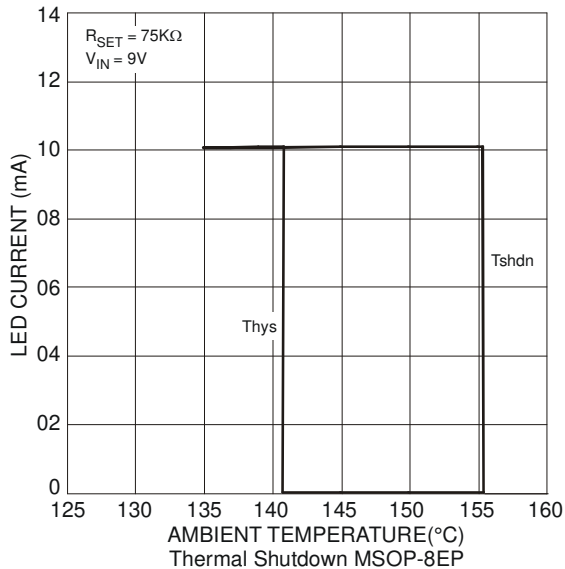
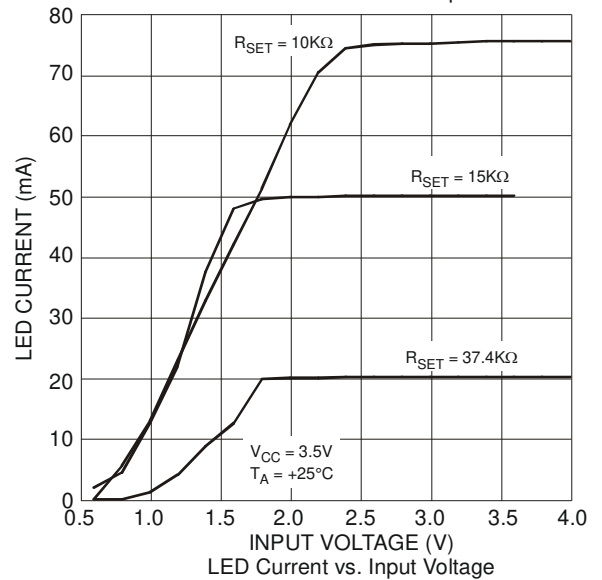
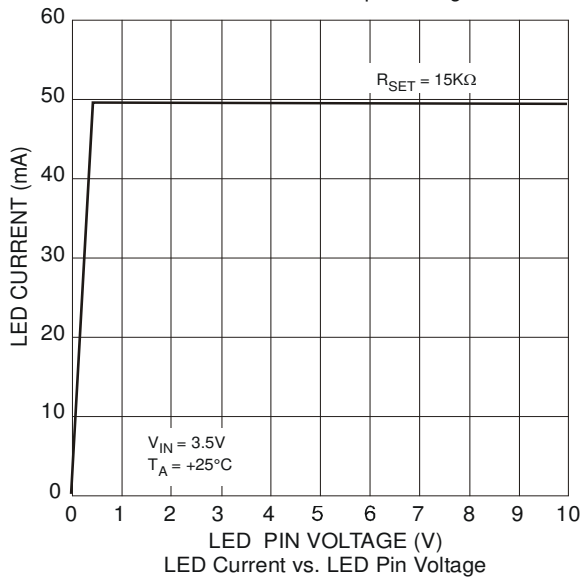
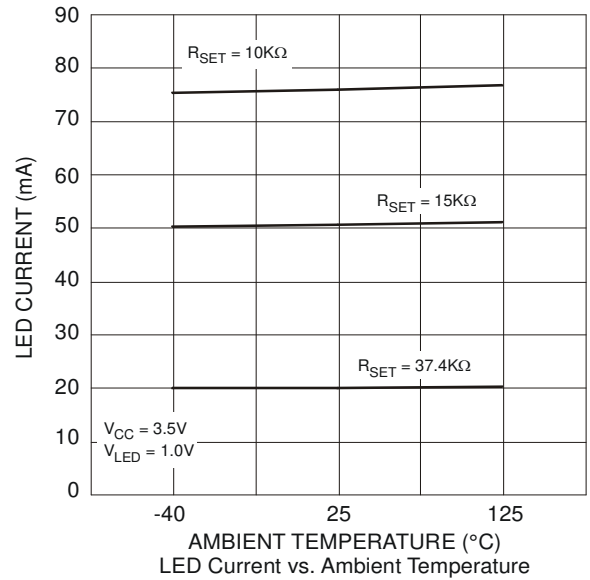
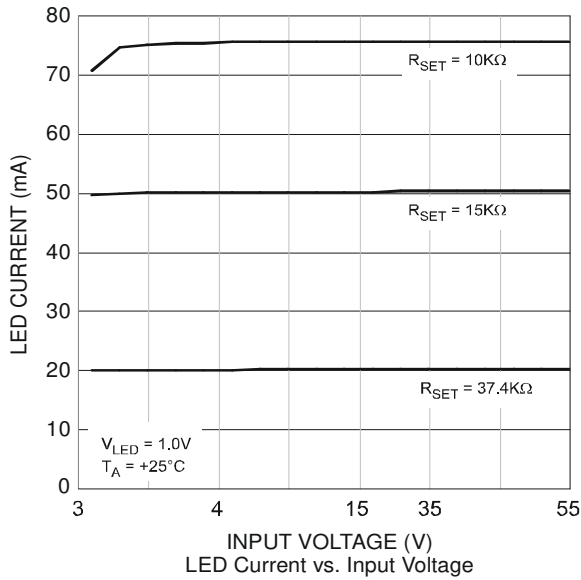

**Typical Performance Characteristics** (Continued)

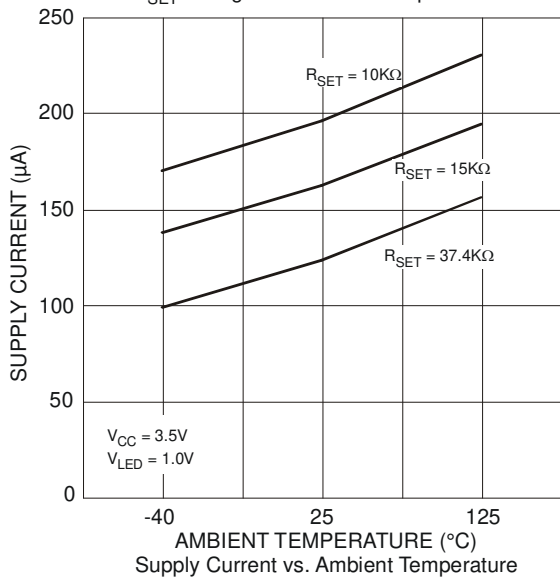
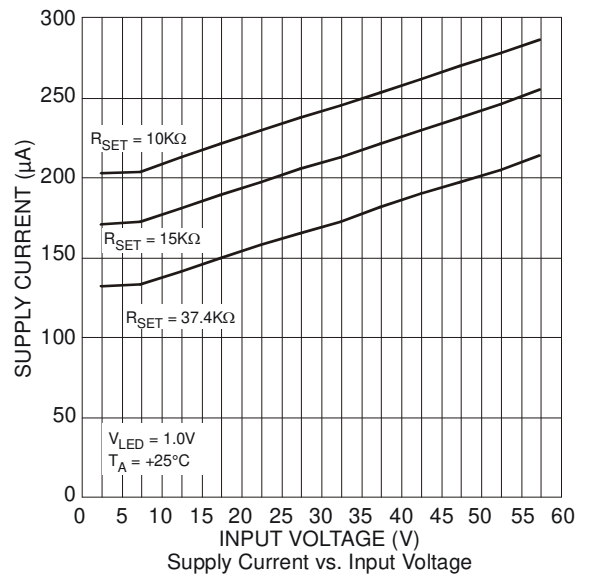
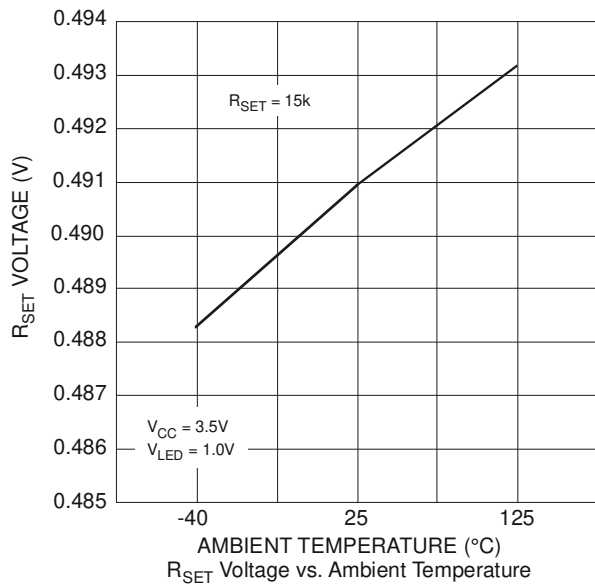

**Typical Performance Characteristics (Cont.)**

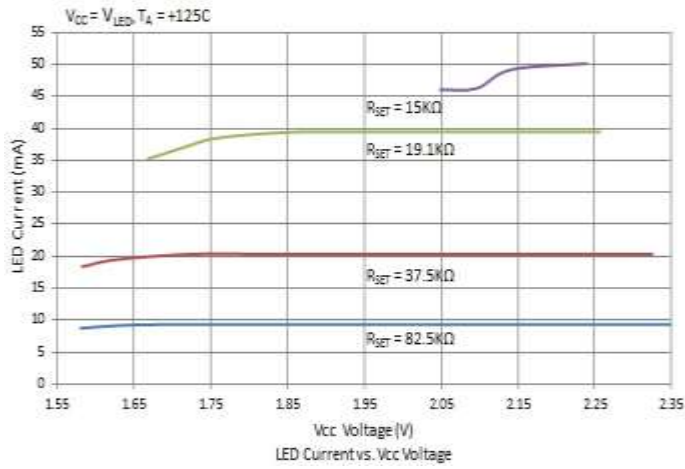
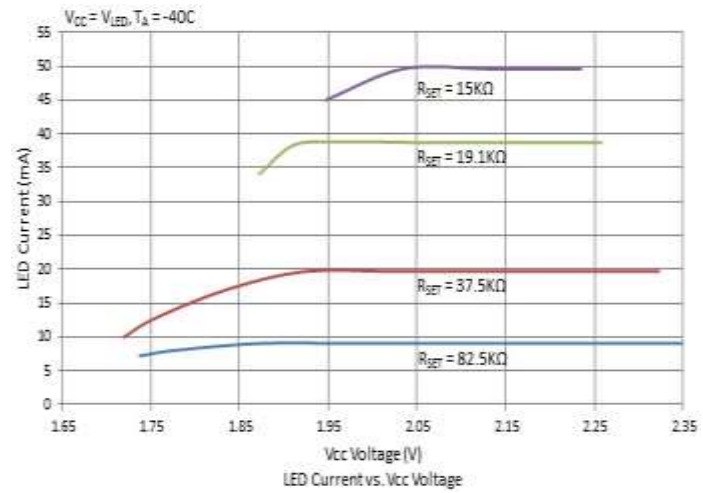
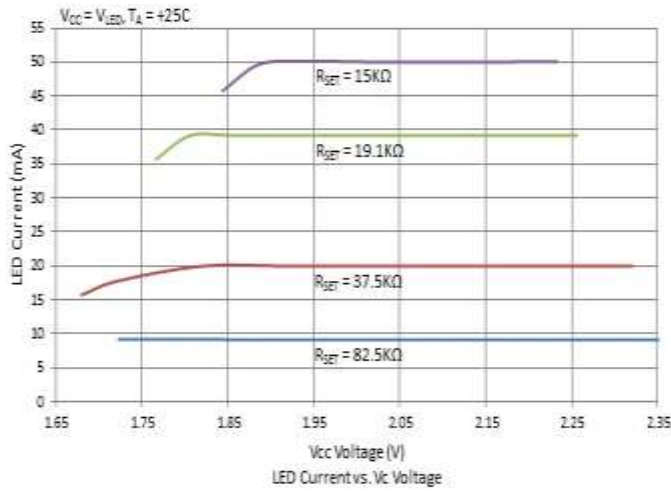

## Application Information

### Description

The AL5811 is a Linear LED driver and in normal operation has the LEDs connected to the same potential as its  $V_{CC}$  pin and regulates the LED current by sinking current into to its LED pin. The LED current is set by the use of an external resistor,  $R_{SET}$ , connected from the  $R_{SET}$  pin to GND. This resistor supplies the bias current of the AL5811 together with current regulator to set the LED current.

The LED current is determined by this equation:

$$I_{LED} = 1500 * \frac{0.5}{R_{SET}} \quad \text{Where: 1500 is the current ratio between the LED pin current and } R_{SET} \text{ pin current.}$$

With  $R_{SET} = 15k$

$$I_{LED} = 1500 * \frac{0.5}{15k} = 50mA$$

The AL5811 with its 60V capability on its supply pin,  $V_{CC}$ , and its LED drive pin allows it to operate from supply rails up to 60V and/or directly drive LED chains up to 60V as shown in Figures 1 and 2. The voltage applied to the  $V_{CC}$  pin can be greater or lower than the voltage applied to the LED string. Figure 2 shows where you might power the AL5811 from a 5V rail and power the LED string from a 12V rail.

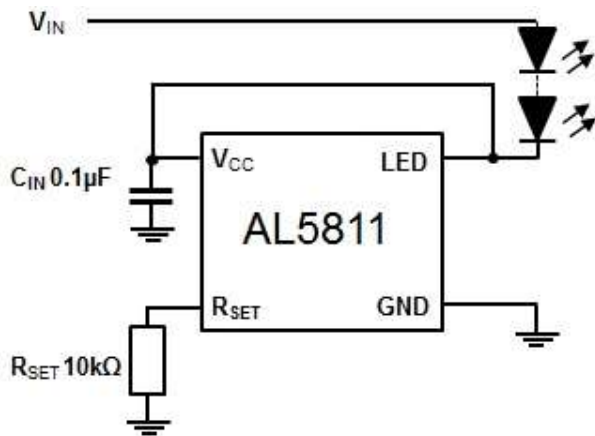

Figure 1 Low Side Current LED Setting

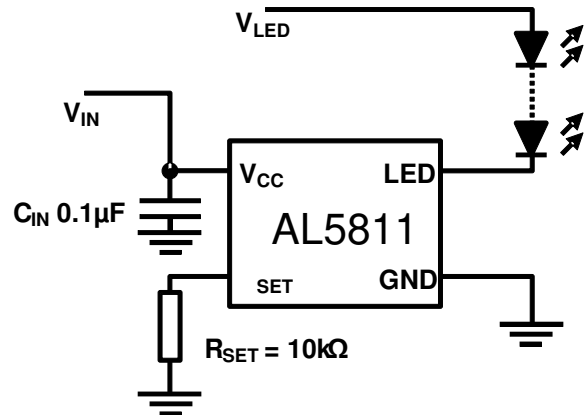
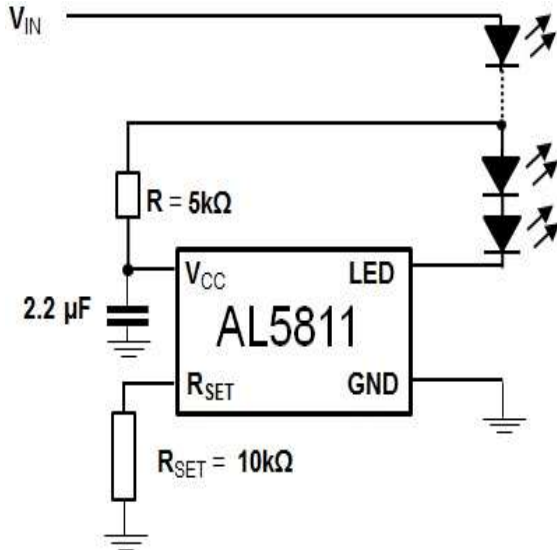

Figure 2 Low Side Current LED Setting  
(Non-Dimming Application Only)

**Application Information** (Continued)

**High Voltage Operation**

An extension of Figure 2 is to derive the power for the AL5811 from the LED chain itself, see Figure 3. LED chains greater than 60V can be driven in this manner as long PWM dimming is not utilized.



**Figure 3 Low Side LED String Tapping**  
(Non-Dimming Application Only)

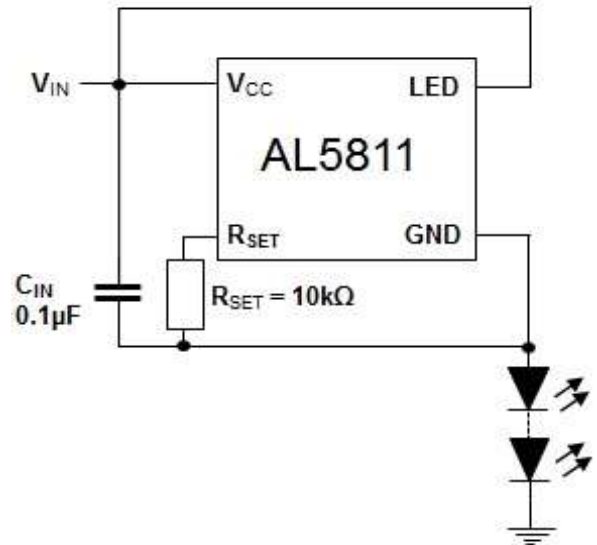

**Figure 4 High Side Current LED String**  
(VCC to GND >= 2.0V)

Figure 2 shows the use of RC delay to match the power time delay between VCC and LED pin. The AL5811 can also be used on the high side of the LEDs, see Figure 3. This is a simple way of extending the maximum LED chain voltage, however, it does increase the minimum system input voltage to:

$$V_{IN(MIN)} = V_{LED\_CHAIN} + 2.0V$$

Where:

V<sub>LED\_CHAIN</sub> is the LED chain voltage



**Application Information (Cont.)**

**PWM Dimming**

LED current dimming can be achieved by driving the R<sub>SET</sub> pin via the current setting resistor (R<sub>SET</sub>) and series MOSFET switch to ground (Figure 5). The R<sub>SET</sub> pin current is then effectively switched on and off causing the LED current to turn on and off.

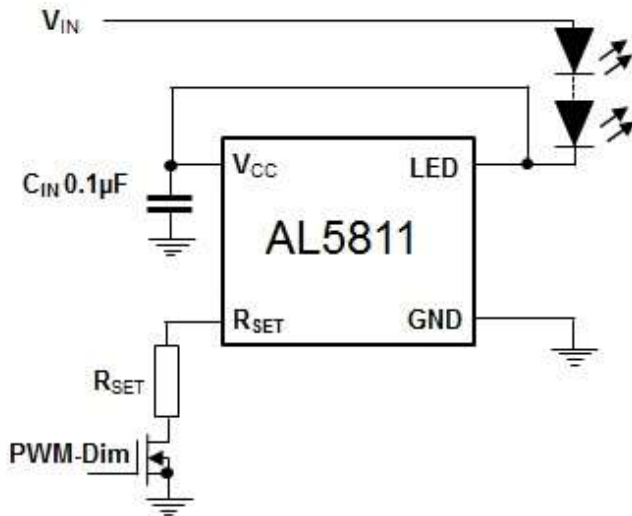

**Figure 5 PWM Dimming**

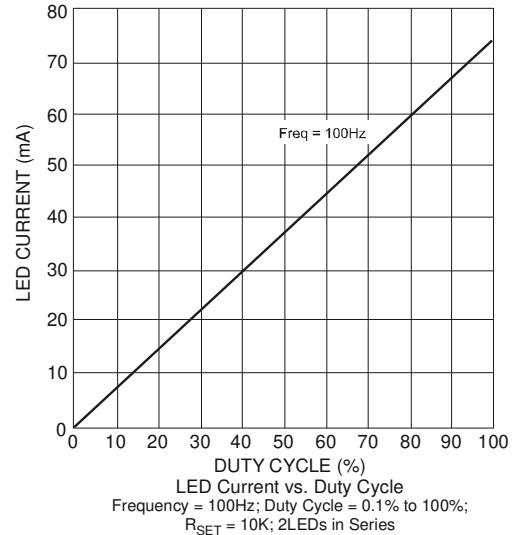

**Figure 6 PWM Dimming Linearity**

**Thermal Considerations**

When designing linear LED drivers careful consideration must be given to:

1. the power dissipation within the LED driver and
2. PCB layout/heat sinking.

A Linear LED driver has to be able to handle the large potential input voltage variations due to the supply voltage tolerance and also the variation in LED forward voltage due to binning and temperature.

This can result in a large potential difference across the LED driver resulting in a larger than anticipated power dissipation.

For example, in a 12V powered system with a 5% output voltage tolerance, the input voltage could typically vary from 12.6V down to 11.4V, driving 3 LEDs with a voltage varying from 3V to 3.5V at 75mA. This means that the LED driver has to cope with a voltage drop across varying from approximately 3.6V to 0.9V. This means that the power dissipation of the AL5811 could be as much as 270mW.

Figure 7 below shows how the AL5811's power dissipation capability varies with package. These values will vary with PCB size and area of metal associated with the ground plane used for heat sinking. By increasing the area on the top layer, the thermal impedance of both packages could be improved.

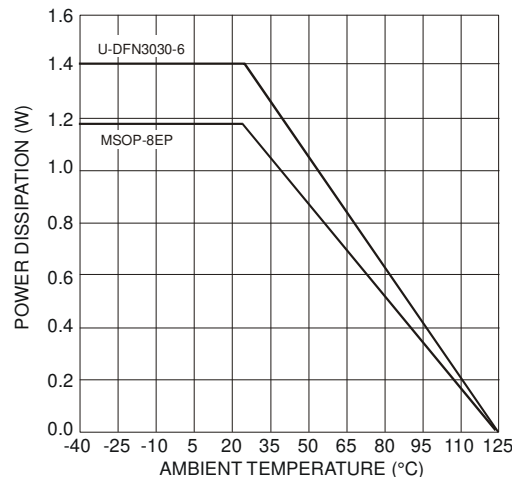

**Figure 7 Power Dissipation Derating**

## Ordering Information (Note 11)

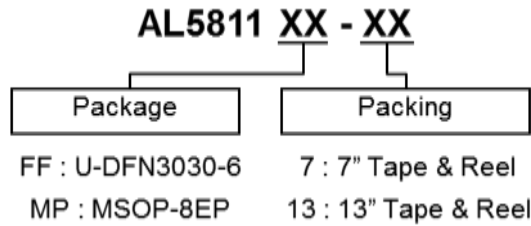

Part Number	Package Code	Packaging	7"/13" Tape and Reel	
			Quantity	Part Number Suffix
AL5811MP-13	MP	MSOP-8EP	2,500/Tape & Reel	-13
AL5811FF-7	FF	U-DFN3030-6	3,000/Tape & Reel	-7

Note: 11. For packaging details, go to our website at <http://www.diodes.com/products/packages.html>.

## Marking Information

### (1) MSOP-8EP

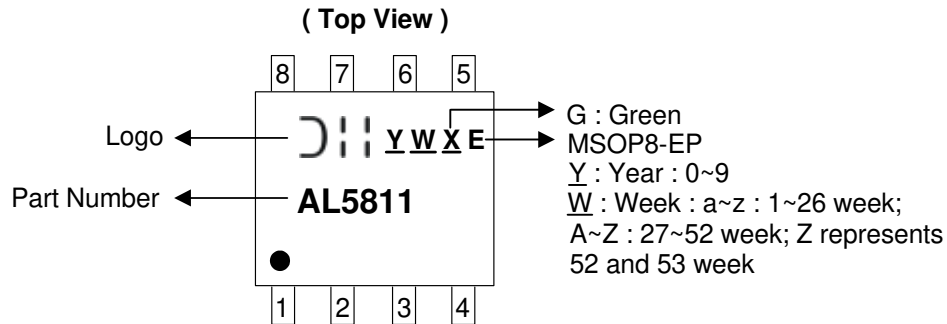

### (2) U-DFN3030-6

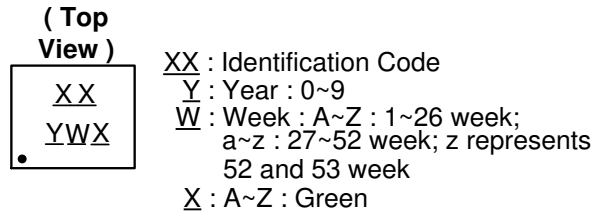

Part Number	Package	Identification Code
AL5811FF-7	U-DFN3030-6	A9

**Package Outline Dimensions**

Please see <http://www.diodes.com/package-outlines.html> for the latest version.

**MSOP-8EP**

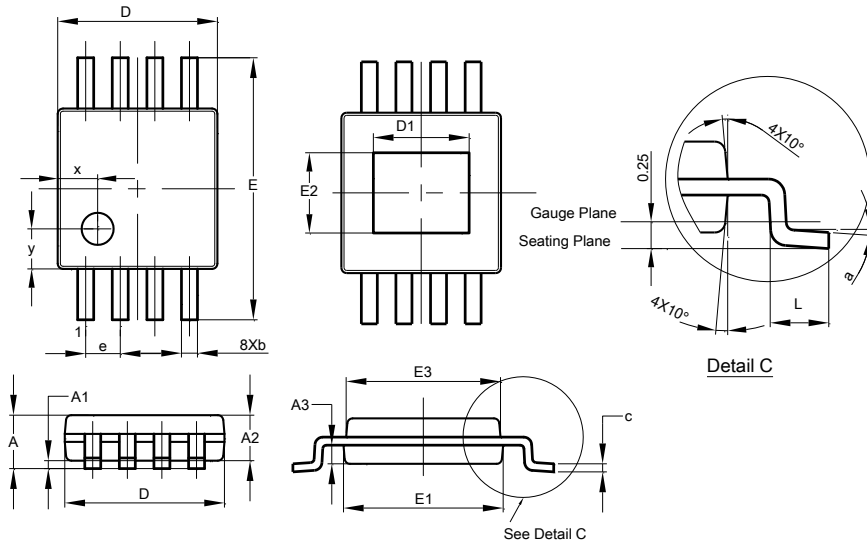

MSOP-8EP			
Dim	Min	Max	Typ
A	-	1.10	-
A1	0.05	0.15	0.10
A2	0.75	0.95	0.86
A3	0.29	0.49	0.39
b	0.22	0.38	0.30
c	0.08	0.23	0.15
D	2.90	3.10	3.00
D1	1.60	2.00	1.80
E	4.70	5.10	4.90
E1	2.90	3.10	3.00
E2	1.30	1.70	1.50
E3	2.85	3.05	2.95
e	-	-	0.65
L	0.40	0.80	0.60
a	0°	8°	4°
x	-	-	0.750
y	-	-	0.750
All Dimensions in mm			

**U-DFN3030-6**

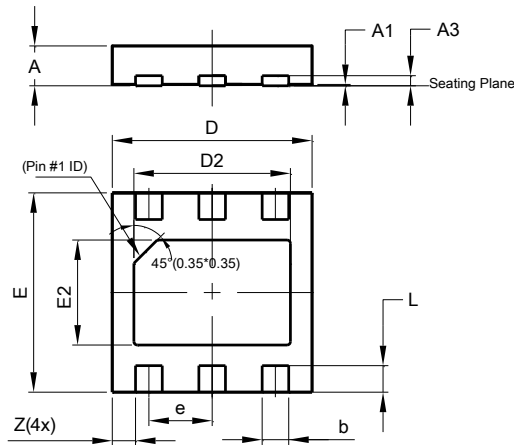

U-DFN3030-6			
Dim	Min	Max	Typ
A	0.57	0.63	0.60
A1	0	0.05	0.02
A3	-	-	0.15
b	0.35	0.45	0.40
D	2.95	3.05	3.00
D2	2.25	2.45	2.35
E	2.95	3.05	3.00
E2	1.48	1.68	1.58
e	-	-	0.95
L	0.35	0.45	0.40
Z	-	-	0.35
All Dimensions in mm			

## Suggested Pad Layout

Please see <http://www.diodes.com/package-outlines.html> for the latest version.

### MSOP8-EP

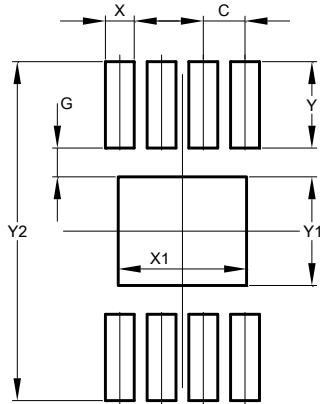

Dimensions	Value (in mm)
C	0.650
G	0.450
X	0.450
X1	2.000
Y	1.350
Y1	1.700
Y2	5.300

### U-DFN3030-6

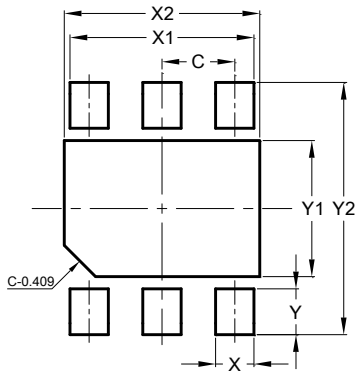

Dimensions	Value (in mm)
C	0.950
X	0.500
X1	2.400
X2	2.550
Y	0.600
Y1	1.780
Y2	3.300

---

**Taping Orientation** (Note 12)

---

U-DFN3030-6

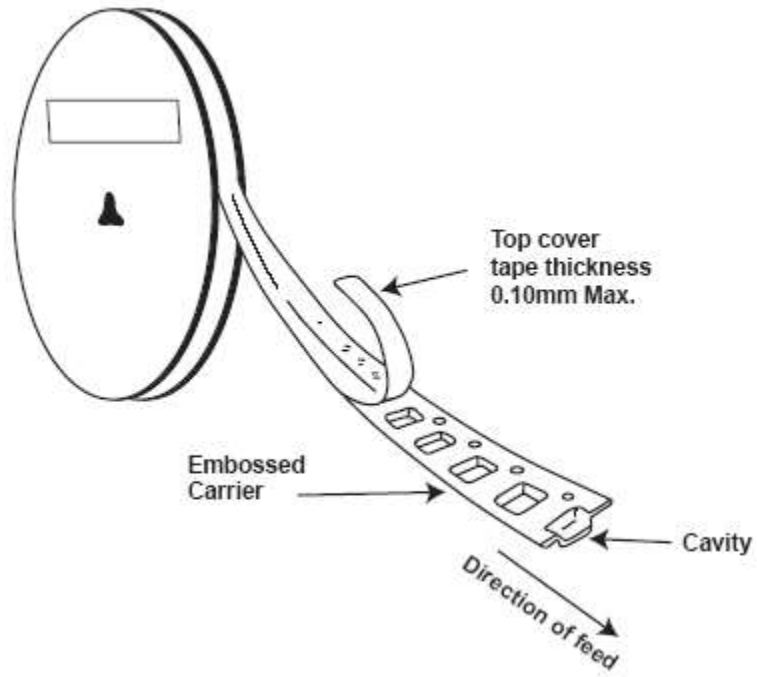
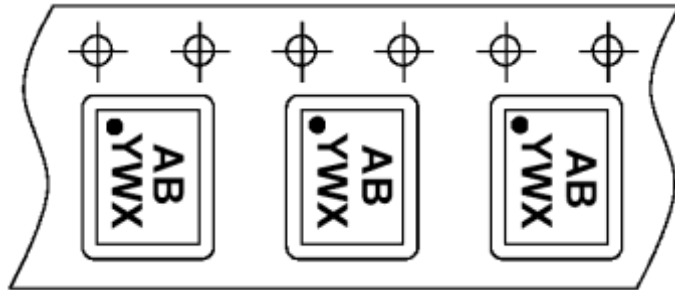

Note: 12. The taping orientation of the other package type can be found on our website at <http://www.diodes.com/datasheets/ap02007.pdf>.

#### IMPORTANT NOTICE

DIODES INCORPORATED MAKES NO WARRANTY OF ANY KIND, EXPRESS OR IMPLIED, WITH REGARDS TO THIS DOCUMENT, INCLUDING, BUT NOT LIMITED TO, THE IMPLIED WARRANTIES OF MERCHANTABILITY AND FITNESS FOR A PARTICULAR PURPOSE (AND THEIR EQUIVALENTS UNDER THE LAWS OF ANY JURISDICTION).

Diodes Incorporated and its subsidiaries reserve the right to make modifications, enhancements, improvements, corrections or other changes without further notice to this document and any product described herein. Diodes Incorporated does not assume any liability arising out of the application or use of this document or any product described herein; neither does Diodes Incorporated convey any license under its patent or trademark rights, nor the rights of others. Any Customer or user of this document or products described herein in such applications shall assume all risks of such use and will agree to hold Diodes Incorporated and all the companies whose products are represented on Diodes Incorporated website, harmless against all damages.

Diodes Incorporated does not warrant or accept any liability whatsoever in respect of any products purchased through unauthorized sales channel. Should Customers purchase or use Diodes Incorporated products for any unintended or unauthorized application, Customers shall indemnify and hold Diodes Incorporated and its representatives harmless against all claims, damages, expenses, and attorney fees arising out of, directly or indirectly, any claim of personal injury or death associated with such unintended or unauthorized application.

Products described herein may be covered by one or more United States, international or foreign patents pending. Product names and markings noted herein may also be covered by one or more United States, international or foreign trademarks.

This document is written in English but may be translated into multiple languages for reference. Only the English version of this document is the final and determinative format released by Diodes Incorporated.

#### LIFE SUPPORT

Diodes Incorporated products are specifically not authorized for use as critical components in life support devices or systems without the express written approval of the Chief Executive Officer of Diodes Incorporated. As used herein:

A. Life support devices or systems are devices or systems which:

1. are intended to implant into the body, or
2. support or sustain life and whose failure to perform when properly used in accordance with instructions for use provided in the labeling can be reasonably expected to result in significant injury to the user.

B. A critical component is any component in a life support device or system whose failure to perform can be reasonably expected to cause the failure of the life support device or to affect its safety or effectiveness.

Customers represent that they have all necessary expertise in the safety and regulatory ramifications of their life support devices or systems, and acknowledge and agree that they are solely responsible for all legal, regulatory and safety-related requirements concerning their products and any use of Diodes Incorporated products in such safety-critical, life support devices or systems, notwithstanding any devices- or systems-related information or support that may be provided by Diodes Incorporated. Further, Customers must fully indemnify Diodes Incorporated and its representatives against any damages arising out of the use of Diodes Incorporated products in such safety-critical, life support devices or systems.

Copyright © 2016, Diodes Incorporated

[www.diodes.com](http://www.diodes.com)