

10 9 8 7 6 5 4 3 2 1

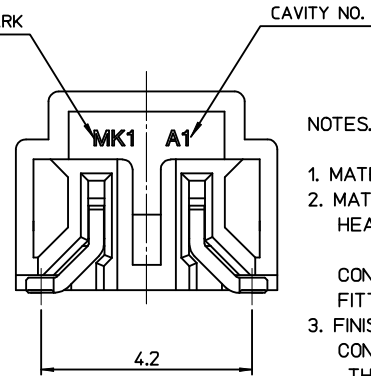
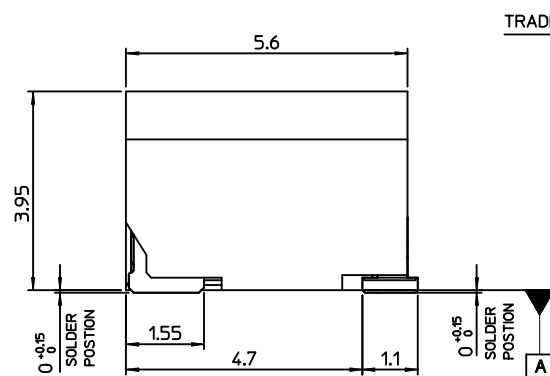
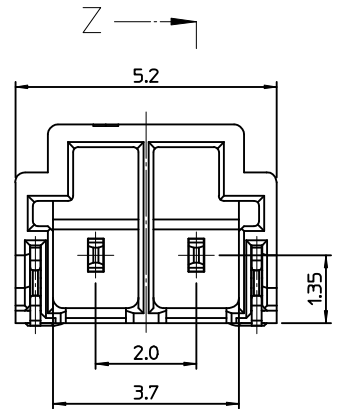
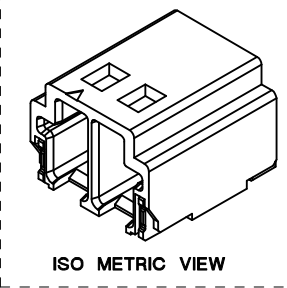
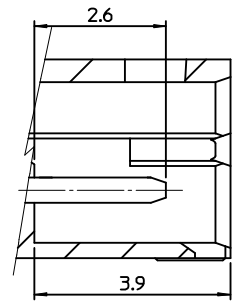
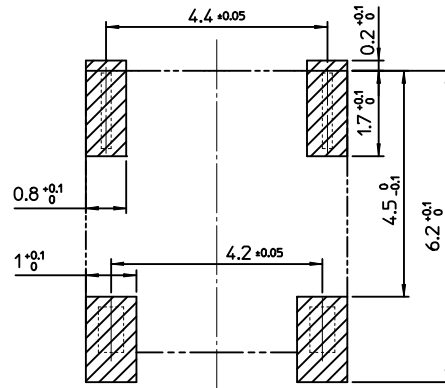
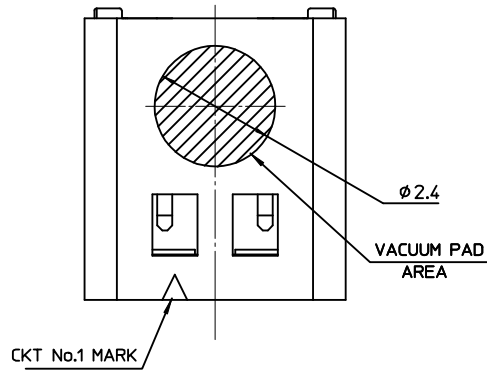

NOTES.

- MATED WITH : 104041-0290
- MATERIALS
 HEADER : LCP, GLASS FILLED, UL94V-0, HALOGEN FREE
 COLOR OF NATURAL(TICONA VECTRA E471I)
 CONTACT TERMINAL : POSPHOR BRONZE
 FITTING NAIL : PHOSPHOR-BRONZE
- FINISHES
 CONTACT TERMINAL : PURE-TIN PLATING ON OVERALL.
 THICKNESS 3.0µm~5.0µm
 UNDER PLATING Ni OVERALL.
 THICKNESS 1.25µm~3.75µm
 FITTING NAIL : PURE-TIN PLATING ON OVERALL.
 THICKNESS 3.0µm~5.0µm
 UNDER PLATING Ni OVERALL.
 THICKNESS 1.25µm~3.75µm
- COPLANALITY OF SOLDER TAILS : 0.08MAX.
- PRODUCT SPECIFICATION : PS-104040-001.
- PACKAGING SPECIFICATION : PK-104040-001

NO.	PART NAME	MATERIAL NO.	CKT
3	FITTING NAIL	104458-8002	2
2	CONTACT TERMINAL	104457-8002	
1	HEADER	104040-0290	

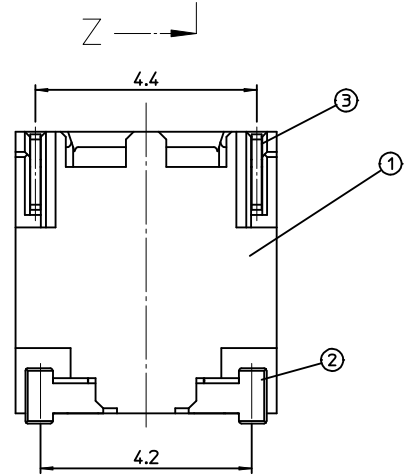

RELEASED EC NO: KOR2010-0018 DRWN:SKHAN 2009/08/07 CHKD:WY.YANG 2009/08/13 APPR:YUNSIKKIM 2009/08/17	QUALITY SYMBOLS	GENERAL TOLERANCES (UNLESS SPECIFIED) mm INCH 4 PLACES ± --- ± --- 3 PLACES ± --- ± --- 2 PLACES ± 0.15 ± --- 1 PLACE ± 0.20 ± --- ANGULAR ± 3°	DIMENSION STYLE	SCALE	DESIGN UNITS	THIRD ANGLE PROJECTION	
	DESCRIPTION		MM ONLY	10:1	METRIC		
	REV		DRAWN BY	DATE	TITLE	HEADER ASS'Y FOR 2.0MM W/B CONN.2P	
			CHECKED BY	DATE	Molex MOLEX INCORPORATED		
	APPROVED BY	DATE	MATERIAL NO.	DOCUMENT NO.	SHEET NO.		
			1040400207	SD-104040-001	1 OF 01		
DRAFT WHERE APPLICABLE MUST REMAIN WITHIN DIMENSIONS			THIS DRAWING CONTAINS INFORMATION THAT IS PROPRIETARY TO MOLEX INCORPORATED AND SHOULD NOT BE USED WITHOUT WRITTEN PERMISSION				

9 8 7 6 5 4 3 2 1