



SG901-1039 Miniature Wi-Fi Radio

This document refers to the SG901-1028 mounted in a Molex connector carrier board

Overview

The SG901-1039 is a single chip based 802.11b/g WLAN radio for embedded, low-power and very small form factor mobile applications. The assembly footprint includes a Molex connector carrier board to facilitate the interface to Sagrad evaluation boards and for special industrial/medical applications where upgrade and simple maintenance is required.

The product conforms to the IEEE 802.11b and 802.11g protocols operating in the 2.45GHz ISM frequency band supporting OFDM data rates of 54, 48, 36, 24, 18, 12, 9, and 6Mbps. It also supports CCK data rates of 11 and 5.5Mbps and legacy data rates of 2 and 1Mbps.

The SG901-1039 is a fully integrated wireless radio including a ZIF transceiver, RF Synthesizer/VCO, high-speed data converters, an OFDM/CCK digital baseband processor, an ARM9-based MAC and a complete Power Management Unit. The on module Power Amplifier completes a highly integrated chip set solution.

Host control is provided by either an SDIO or SPI interface.

This complete design allows quick integration into a number of different applications.

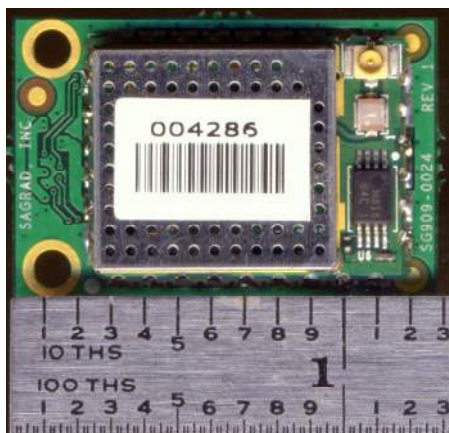

Features

- FCC Module Certification
- RoHs Compliant
- Fully integrated 802.11 Solution
- Custom drivers available for your host
- Extremely small footprint
- Ultra Low Current consumption
- Fully compliant with the IEEE 802.11b and 802.11g WLAN standards
- Support for 54, 48, 36, 24, 18, 12, 9, and 6Mbps OFDM, 11 and 5.5Mbps CCK and Legacy 2 and 1Mbps data rates
- Single Chip 802.11b/g WLAN solution with fully integrated:
 - Zero IF (ZIF) transceiver,
 - Voltage Controlled Oscillator (VCO),
 - High-Speed A/D and D/A Converters,
 - Radio Power Management Unit (PMU) with on-board supply regulators,
 - OFDM and CCK baseband processor,
 - ARM9 Media Access Controller (MAC),
 - SPI serial host interface (up to 48MHz)
 - SDIO serial host interface (up to 50MHz)
- Intelligent Power Control, Including 802.11 Power Save Mode
- Supports SPI interface
- Supports SDIO interface

Applications

- Personal Digital Assistants (PDA)
- Portable Computers
- Hand-held Data Transfer Devices
- Cameras
- Computer Peripherals
- Cable Replacement
- Cellular Phones

Ordering Information

Packaging	Order Number
Bulk Only	SG901-1039-C-BLK (Commercial)
	SG901-1039-ET-BLK (Ext. Temp)



Block Diagram

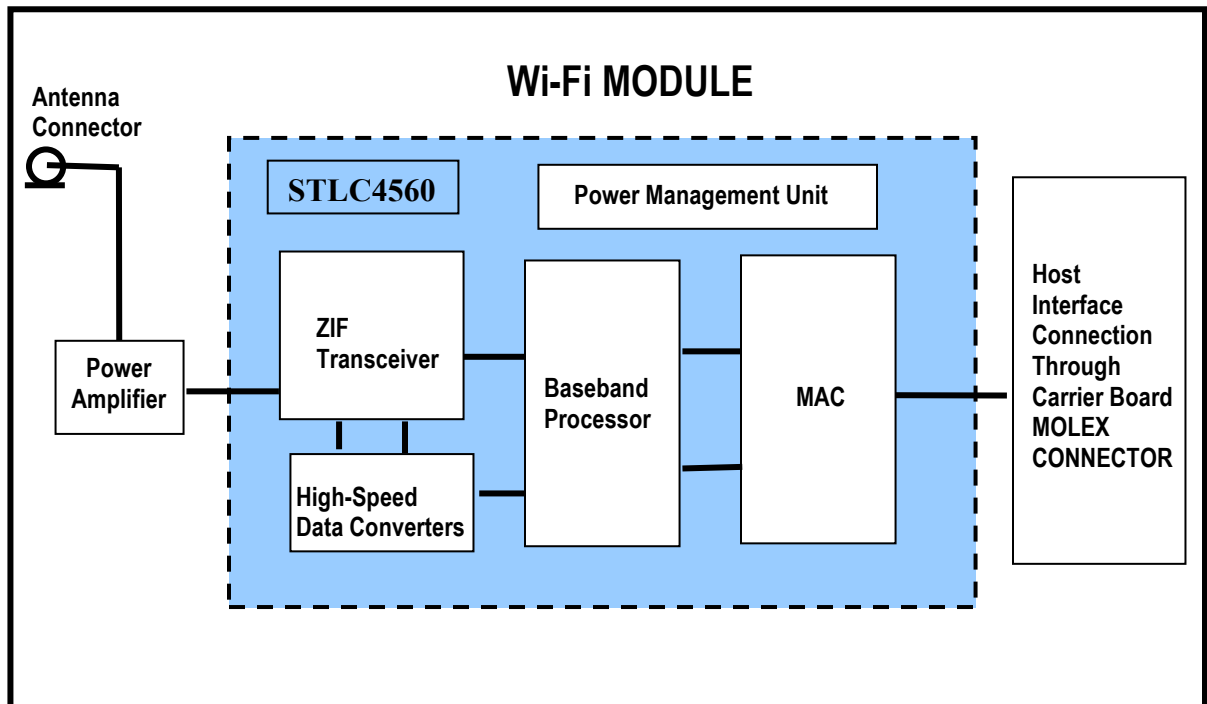

SAGRAD SG901-1039 Radio Block Diagram



General Electrical Specifications

Parameter	Test Condition / Comment	Min.	Typ.	Max.	Units		
Absolute Maximum Ratings							
3.3V Supply		-0.3		4.0	V		
Operating Conditions and Input Power Specifications							
Operating Temperature Range (See ordering information)	Commercial	0		70	°C		
	Extended Temperature	-30		85	°C		
3.3V Supply	Input Supply Voltage	Power Management Unit 3.3V Supply input		3.0	3.3	5.5	V
	Standby Mode Current	3.3V, 25°C, POWERUP=1.8V, Sleep clock 32.768kHz				0.5	mA
	Power Save Mode Current	100mS beacon period, 75 byte beacons @ 1Mbps, short Preamble, DTIM = 3				2	mA
	Shutdown Current	3.3V 25°C, POWERUP=0V				8	uA
	Peak TX Current	During Transmitting packets, 3.3V, 25°C		420		520	mA
	Peak RX Current	During Receiving packets, 3.3V, 25°C			253		mA
VHIO Supply	Input Supply Voltage	VHIO input supply determines Host CMOS logic levels		1.62	1.8	1.98	V
	Input Supply Current	VHIO = 1.8V			0.5	6	mA
	Standby Mode Current	VHIO = 1.8V			10		uA

Digital Interface Specifications (25°C)

Parameter	Test Condition / Comment	Min.	Typ.	Max.	Units	
Digital Interface Specifications						
POWER UP Input	VIH	PMU Power up control. Active High		0.8	1.98	V
	VIL			0	0.3	V
	Pull-Down				500	kΩ
Host CMOS Inputs	VIH	VHIO supply domain		0.7*VHIO	VHIO	V
	VIL			0	0.3*VHIO	V
Host CMOS Outputs	VOH	IOH = 0.2mA, VHIO supply domain		VHIO - 0.2	VHIO	V
	VOL	IOL = 2mA, VHIO supply domain		0	0.4	V
	Input Current	VHIO supply domain		-1.0	+1.0	uA
SLEEP_CLK Input	Frequency	VHIO supply domain			32.768	kHz
	Accuracy				500	ppm
	Duty Cycle			30	70	%

RF Characteristics (25°C)

Parameter	Test Condition / Comment	Min.	Typ.	Max.	Units	
RF Frequency Range		2400		2500	MHz	
RF Output Power	802.11 G 54Meg	Meeting FCC and 802.11 EVM		12		dBm
	802.11 G 6Meg	Meeting FCC and 802.11 EVM			15	dBm
	802.11 B 11Meg	Meeting FCC and 802.11 EVM			15	dBm
Receiver Sensitivity	802.11 G 54Meg	10% PER		-68		dBm
	802.11 G 6Meg			-88		dBm
FCC Compliance	Passed FCC part 15C					

Note 1: Output Power is measured at the RF Antenna



Inputs/Outputs Required

		Comment
Digital Connector	Part Number	Molex 53748-0308
	Location	Bottom Side 30 Pins
RF Connector	Part Number	Hirose U.FL-R-SMT(10)
	Location	Top Side
Power	3.3V	Input Supply Voltage

Connector Pin Description

SIGNAL NAME	PIN NUMBER	DESCRIPTION	NOTES
VHIO	20,21,22	Supply Voltage for I/O's	Recommended I/O voltage range 1.6V to 2.0V (nominal 1.8V) (see note 1).
SPI_CS _n	10	SPI: Serial Host Chip Select/SDIO: Data 3	
SPI_DI	9	SPI: Serial Host Data Input/SDIO: Data 0	
SPI_CLK	18	SPI: Clock/SDIO: CLK	
SPI_DO	14	SPI: Serial Host Data Output/SDIO: CMD	
SDIO_SDAT2	17	SDIO: Data 2	
IRQ	5	SPI: Serial Host Interrupt/SDIO: Data 1	
SERHOSTMODE	19	SPI/SDIO Select	High = SPI, Low = SDIO
POWER UP	6	Power Up Enable (from host)	High = normal mode, Low = Sleep Mode
SLEEPCLK	13	32.768 kHz Sleep Clock	
3.3V	3,4,11,12,25,26,27,28	Input Supply	Further decoupling may be required to sustain 250mA inrush currents during packet transmission
GND	1, 2, 7, 8, 15, 16, 23, 24, 29, 30	Ground Connections	

Note 1: This I/O supply operates to 3.3V. It is recommended that a level translator to 1.8V be used on host applications beyond 2.0V (i.e. TI-TXS0108 for SDIO).



Encryption Support

Feature	Windows	Linux	CE
Security			
WEP	Yes	Yes	Yes
TKIP	Yes	Yes	Yes
AES/CCMP (HW accel)	Yes	Yes	Yes
WPA	Yes-WZC	Third Party Supplicant	WZC (shared key), Third party suppl.
WPA2	Yes	Third Party Supplicant	Third Party Supplicant
QoS			
HCF (Q1/2006)	Q1/06	Q1/06	Q1/06
WMM	Yes	Yes	Yes
WMM U-APSD	Yes	Yes	Yes
EDCF	Yes	Yes	Yes
WMM-SA (Q1/2006)	Q1/06	Q1/06	Q1/06
Cisco Standards			
CCX v1	Yes	Third Party Supplicant	Third Party Supplicant
CCX v2	Yes	Third Party Supplicant	Third Party Supplicant
Certifications			
802.11d Support	Yes	Yes	Yes
WiFi Certification	Yes	Yes*	Yes* (XP certification transfers)
WHQL	NA	NA	NA
Bluetooth Coexistence			
PTA (802.15.2)	Yes	Yes	Yes
802.11/BT on same Antenna	Yes	Yes	Yes
802.11/BT on 2 Antennas	Yes	Yes	Yes
Data and Voice Simultaneously	Yes	Yes	Yes
Data and Data Simultaneously	Yes	Yes	Yes
Voice and Voice Simultaneously	Yes	Yes	Yes

*Throughput depends on SPI speed. We recommend a 33Mhz SPI to pass WiFi PDA Throughput requirements



Software Support

	Little Endian	Big Endian
Arm	X	
Arm4	X	
Arm9e	X	
Armi	X	
i386	X	
mips	X	X
powerpc		X
sh		X
sh4	X	
thumb	X	
xscale	X	X

HW/SW Overview - SoftMAC Architecture

- **User Space, WPA Supplicant**
 - Supplicant required to:
 - Handle user input/configuration
 - WPA handshaking
 - Transport protocol (EAP/PEAP)
 - Handle certificates
 - Install keys in UMAC
- **Wi-Fi DRIVER**
 - Allows for porting to custom embedded OS and Processor
- **UMAC**
 - Binary Library file
 - Links with driver
 - Provides configuration API to:
 - Select encryption type
 - Set Key
 - Handles initial Authentication/Association to the AP
 - Configures LMAC for the correct encryption
- **LMAC**
 - Binary file, contains ARM executable code
 - Hardware encryption/decryption of data according to configured encryption type and key.

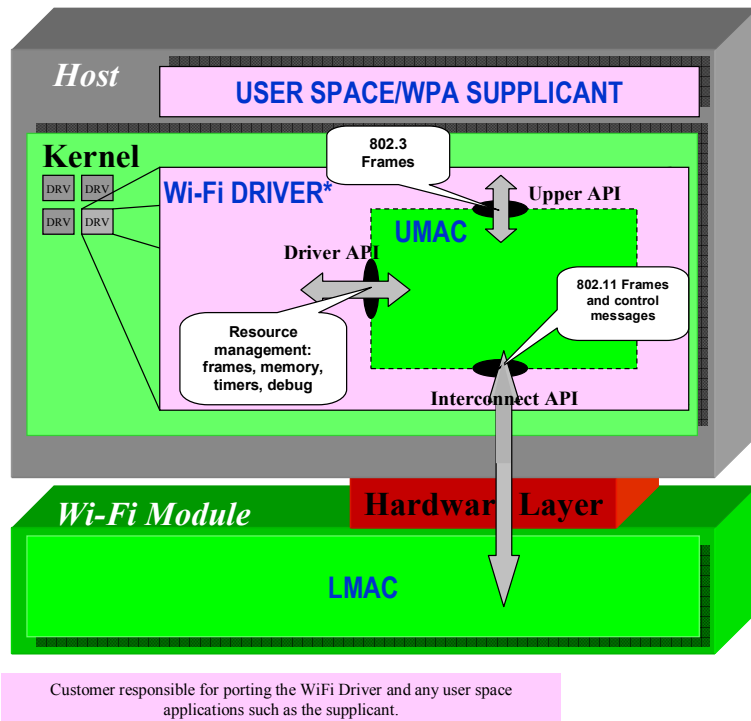



Implementation

The SG901-1039 uses the Molex 53748-0308 connector. The following Molex connectors can be used to mate to the SG901-1039 module:

- 52991-0308 (White)
- 54167-0308 (Black)

Implementation Schematic

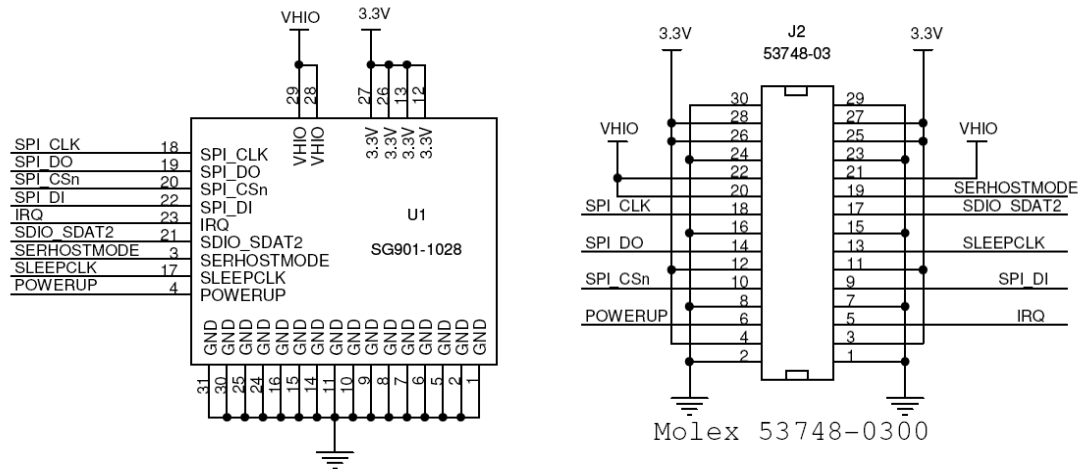



Sagrad Evaluation Platforms

EV Kit for SPI interface



- (1) SG901-1039 802.11 b & g fully FCC certified Wi-Fi module soldered on a carrier board
- (1) PCMCIA board for SPI applications
- (1) Interposer board
- (1) Software Driver CD
- (1) Data sheet for the SG901-1039
- (1) Schematics of interposer board
- (1) Schematics of PCMCIA board

EV Kit for SDIO interface



- (1) SG901-1039 802.11 b & g fully FCC certified Wi-Fi module soldered on carrier board
- (1) SDIO interface board for SDIO applications
- (1) Software Driver CD
- (1) Data sheet for the SG901-1039
- (1) Schematics of SDIO board



Mechanical

- Maximum Peak Reflow Temperature: 240°C
- Moisture Level Sensitivity : 3

Module Dimensions:

Parameter		Min.	Typ.	Max.	Units
Dimension	Length		33.25		mm
	Width		22.30		mm
	Height		8.63		mm

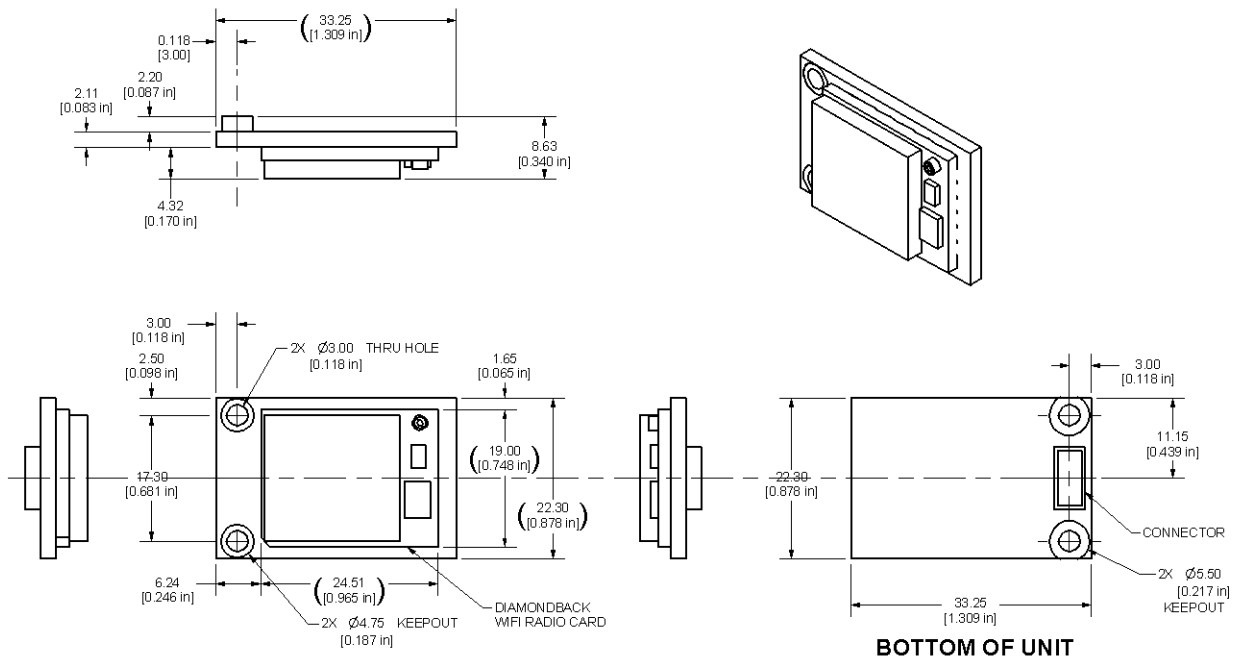



Mechanical, continued

Suggested Stand-off's:

Swage Threaded Standoffs

Round or Hex

2-56 Thread x .156 O.D. (5/32")

Use Staking Tool: **Cat. No. TL-19**

Round Cat. No. "H" "L" For Panel Thickness **HEX Cat. No.**

1589-2 .125 [3,17] .109 [2,77] 1/16 **1731-2**

1589-3 .125 [3,17] .140 [3,56] 3/32 **1731-3**

1590-2 .187 [4,75] .109 [2,77] 1/16 **1734-2**

1590-3 .187 [4,75] .140 [3,56] 3/32 **1734-3**

1591-2 .250 [6,35] .109 [2,77] 1/16 **1740-2**

1591-3 .250 [6,35] .140 [3,56] 3/32 **1740-3**

1596-2 .375 [9,52] .109 [2,77] 1/16 **1743-2**

1596-3 .375 [9,52] .140 [3,56] 3/32 **1743-3**

Keystone: <http://www.keyelco.com/pdfs/M55p65.pdf>

Use Staking Tool: Cat. No. TL-19