

CONNECTOR P/N	BOOT COLOR	CONNECTOR TYPE
106002-3000	BEIGE	MALE MM
106003-3000		FEMALE MM
106002-5000	BLUE	MALE SM
106003-5000		FEMALE SM
106002-3030	BLACK	MALE MM
106002-3040*		MALE MM
106003-3030		FEMALE MM
106003-3040*	RED	FEMALE MM
106002-3031		MALE MM
106003-3033		FEMALE MM
106002-3032	BLUE	MALE MM
106003-3034		FEMALE MM

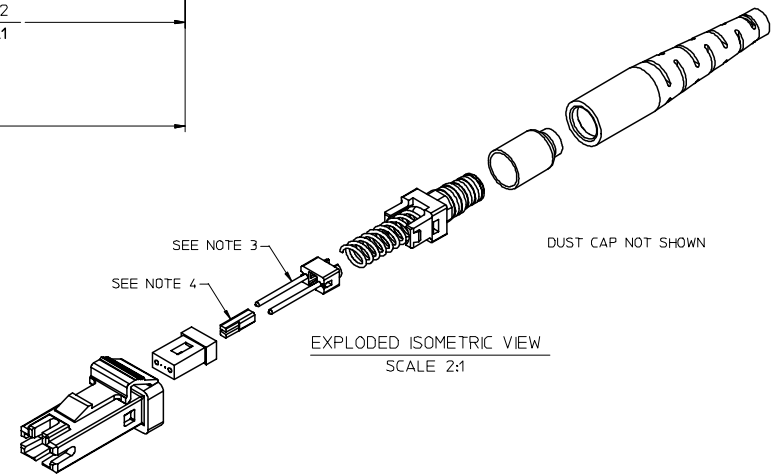
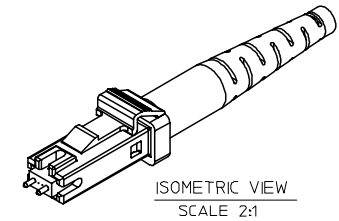
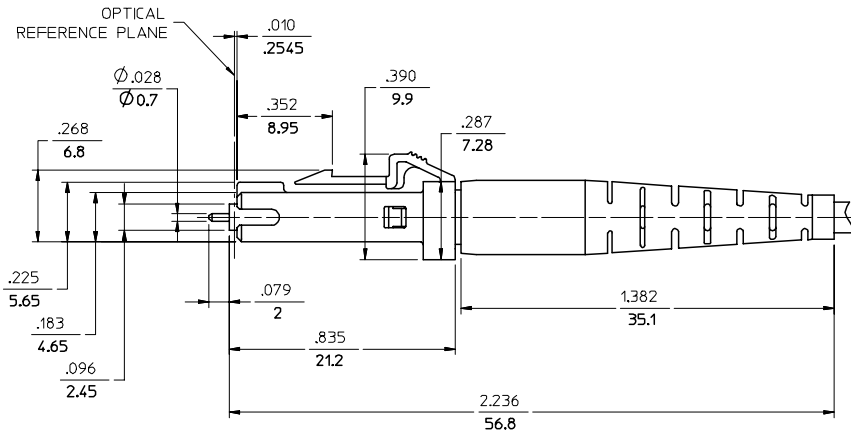
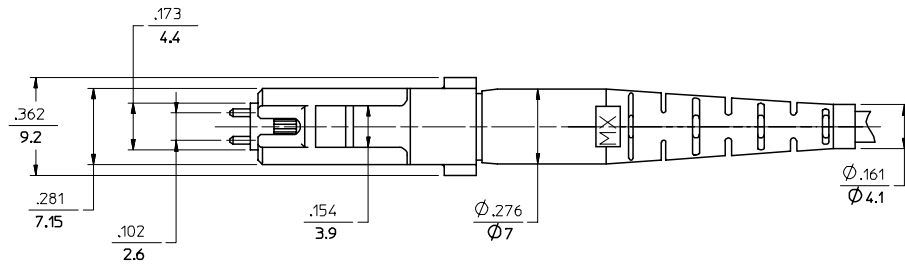

AVAILABLE CABLE TYPES

CABLE TYPE 1	CABLE TYPE 2	CABLE TYPE 3
2 FIBER DUAL LINK WITH Ø2.8mm JACKET	3.5mm X 1.6mm 2 FIBER ZPCORD	2 FIBER RIBBON WITH Ø2.9mm JACKET

NOTES:

- DUST CAP NOT SHOWN, BUT INCLUDED.
- MALE CONNECTOR SHOWN. FEMALE CONNECTOR DOES NOT CONTAIN PINS.
- CABLE TYPE 1 & 2 DO NOT REQUIRE FERRULE BOOT.
- SEE PROCEDURE 0A1131 FOR ASSEMBLY INSTRUCTIONS.
- P/N 106002-3040 AND 106003-3040 ARE BULK PACKED.

ENTER DESCRIPTION EC NO: MF2006-0340 DRAWN/RPAC I/C 2005/11/29 CHKD: 2005/11/29 APPR: JGUMIN 2005/11/29 REVISIONS A	QUALITY SYMBOLS ▽=0 ▽=0	GENERAL TOLERANCES (UNLESS SPECIFIED)		DIMENSION STYLE IN/MM	SCALE 3:1	DESIGN UNITS INCH	THIRD ANGLE PROJECTION		
		4 PLACES ± --- ± --- 3 PLACES ± --- ± --- 2 PLACES ± --- ± --- 1 PLACE ± --- ± ---	mm INCH	DRAWN BY RPAC I/C I	DATE 2005/10/20	TITLE MT-RJ CONNECTOR			
		ANGULAR ±1/2°		CHECKED BY	DATE	APPROVED BY			
		DRAFT WHERE APPLICABLE MUST REMAIN WITHIN DIMENSIONS		MATERIAL NO. SEE TABLE	DATE	DOCUMENT NO. SD-10600X-X0X0	SHEET NO. 1 OF 1		