

General Description

The MAX6826–MAX6831 are ultra-low-voltage microprocessor (μ P) supervisory circuits designed to monitor two power supplies and have manual reset and watchdog input functions. These devices assert a system reset if any of the monitored supplies fall below the preprogrammed thresholds, and maintain reset for a minimum timeout period after the supplies rise above the threshold. Microprocessor supervisors significantly improve system reliability and accuracy compared to separate ICs or discrete components. These devices monitor primary voltages from +1.8V to +5.0V and secondary voltages from +0.9V to +2.5V. These devices are guaranteed to be in the correct state for V_{CC} down to +1.0V.

A variety of preprogrammed reset threshold voltages are available (see the *Threshold Suffix Guide*). The devices include manual reset and watchdog inputs. The MAX6829/MAX6830/MAX6831 provide a factory-trimmed threshold to monitor a 2nd voltage down to +0.9V. The MAX6826/MAX6829 have a push-pull \overline{RESET} , the MAX6827/MAX6830 have a push-pull \overline{RESET} and the MAX6828/MAX6831 have an open-drain \overline{RESET} . The MAX6826/MAX6827/MAX6828 have an auxiliary monitor that allows user adjustable input to monitor voltages down to +0.6V. see *Selector Guide* for functions available.

Applications

- Portable/Battery-Powered Equipment
- Embedded Controllers
- Intelligent Instruments
- Critical μ P Monitoring
- Multivoltage Systems

Pin Configuration

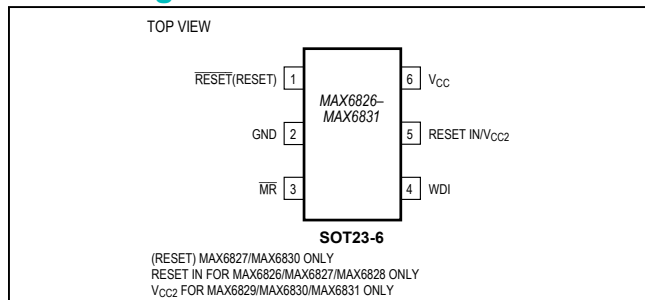

Typical Operating Circuit, Threshold Suffix Guide, and Selector Guide appear at end of data sheet.

Features

- Monitor Primary V_{CC} Supplies from +1.8V to +5.0V and Secondary V_{CC2} Supplies from +0.9V to +2.5V
- User Adjustable \overline{RESET} IN Down to +0.63V (MAX6826/MAX6827/MAX6828)
- 140ms (min) Reset Timeout Delay
- 1.6s Watchdog Timeout Period
- Manual Reset Input
- Three Reset Output Options
 Push-Pull \overline{RESET}
 Push-Pull \overline{RESET}
 Open-Drain \overline{RESET}
- Guaranteed Reset Valid Down to $V_{CC} = +1.0V$
- Immune to Short Negative V_{CC} Transients
- No External Components
- Small 6-pin SOT23 Packages

Ordering Information

PART†	TEMP RANGE	PIN-PACKAGE
MAX6826__UT-T	-40°C to +125°C	6 SOT23
MAX6827__UT-T	-40°C to +125°C	6 SOT23
MAX6828__UT-T	-40°C to +125°C	6 SOT23
MAX6829__UT-T	-40°C to +125°C	6 SOT23
MAX6830__UT-T	-40°C to +125°C	6 SOT23
MAX6831__UT-T	-40°C to +125°C	6 SOT23

†Insert the desired suffix letter (from Standard versions table) into the blanks to complete the part number.

Devices are available in both leaded and lead-free packaging. Specify lead-free by replacing “-T” with “+T” when ordering.

Standard Versions Table*

MAX6826/MAX6827/MAX6828
L
S
R
Z
V

*Samples are typically available for standard versions only. The MAX6826/MAX6827/MAX6828 require a 2.5k minimum order increment for all versions. Contact factory for availability.

Standard Versions Table continued at end of data sheet.

Absolute Maximum Ratings

V_{CC}, V_{CC2} to GND.....	-0.3V to +6.0V	Operating Temperature Range.....	-40°C to +125°C
Open-Drain $\overline{\text{RESET}}$	-0.3V to +6.0V	Junction Temperature.....	+150°C
Push-Pull $\overline{\text{RESET}}, \text{RESET}$	-0.3V to ($V_{CC} + 0.3\text{V}$)	Storage Temperature Range.....	-65°C to +150°C
MR, WDI, RESET IN.....	-0.3V to ($V_{CC} + 0.3\text{V}$)	Lead Temperature (soldering, 10s).....	+300°C
Input Current (V_{CC}).....	20mA		
Output Current ($\overline{\text{RESET}}, \text{RESET}$).....	20mA		
Continuous Power Dissipation ($T_A = +70^\circ\text{C}$)			
6-Pin SOT23 (derate 8.7mW/°C above +70°C).....	696mW		

Stresses beyond those listed under "Absolute Maximum Ratings" may cause permanent damage to the device. These are stress ratings only, and functional operation of the device at these or any other conditions beyond those indicated in the operational sections of the specifications is not implied. Exposure to absolute maximum rating conditions for extended periods may affect device reliability.

Electrical Characteristics

($V_{CC} = +4.5\text{V}$ to $+5.5\text{V}$ for MAX68__L/M, $V_{CC} = +2.7\text{V}$ to $+3.6\text{V}$ for MAX68__T/S/R, $V_{CC} = +2.1\text{V}$ to $+2.75\text{V}$ for MAX68__Z/Y, $V_{CC} = +1.53\text{V}$ to $+2.0\text{V}$ for MAX68__W/V; $T_A = -40^\circ\text{C}$ to $+125^\circ\text{C}$, unless otherwise specified. Typical values are at $T_A = +25^\circ\text{C}$.) (Note 1)

PARAMETER	SYMBOL	CONDITIONS		MIN	TYP	MAX	UNITS
Operating Voltage Range	V_{CC}	$T_A = 0^\circ\text{C}$ to $+85^\circ\text{C}$		1.0		5.5	V
		$T_A = -40^\circ\text{C}$ to $+125^\circ\text{C}$		1.2		5.5	
V_{CC} Supply Current MR and WDI Unconnected	I_{CC}	$V_{CC} = +5.5\text{V}$, no load	$T_A = -40^\circ\text{C}$ to $+85^\circ\text{C}$		10	20	μA
			$T_A = -40^\circ\text{C}$ to $+125^\circ\text{C}$			30	
		$V_{CC} = +3.6\text{V}$, no load	$T_A = -40^\circ\text{C}$ to $+85^\circ\text{C}$		7	16	
			$T_A = -40^\circ\text{C}$ to $+125^\circ\text{C}$			25	
V_{CC2} Supply Current		$V_{CC2} \leq +2.5\text{V}$				2	μA
V_{CC} Reset Threshold (V_{CC} Falling)	V_{TH}	MAX68__L	$T_A = -40^\circ\text{C}$ to $+85^\circ\text{C}$	4.50	4.63	4.75	V
			$T_A = -40^\circ\text{C}$ to $+125^\circ\text{C}$	4.47	4.63	4.78	
		MAX68__M	$T_A = -40^\circ\text{C}$ to $+85^\circ\text{C}$	4.25	4.38	4.50	
			$T_A = -40^\circ\text{C}$ to $+125^\circ\text{C}$	4.22	4.38	4.53	
		MAX68__T	$T_A = -40^\circ\text{C}$ to $+85^\circ\text{C}$	3.00	3.08	3.15	
			$T_A = -40^\circ\text{C}$ to $+125^\circ\text{C}$	2.97	3.08	3.17	
		MAX68__S	$T_A = -40^\circ\text{C}$ to $+85^\circ\text{C}$	2.85	2.93	3.00	
			$T_A = -40^\circ\text{C}$ to $+125^\circ\text{C}$	2.83	2.93	3.02	
		MAX68__R	$T_A = -40^\circ\text{C}$ to $+85^\circ\text{C}$	2.55	2.63	2.70	
			$T_A = -40^\circ\text{C}$ to $+125^\circ\text{C}$	2.53	2.63	2.72	
		MAX68__Z	$T_A = -40^\circ\text{C}$ to $+85^\circ\text{C}$	2.25	2.32	2.38	
			$T_A = -40^\circ\text{C}$ to $+125^\circ\text{C}$	2.24	2.32	2.40	
		MAX68__Y	$T_A = -40^\circ\text{C}$ to $+85^\circ\text{C}$	2.12	2.19	2.25	
			$T_A = -40^\circ\text{C}$ to $+125^\circ\text{C}$	2.11	2.19	2.26	
		MAX68__W	$T_A = -40^\circ\text{C}$ to $+85^\circ\text{C}$	1.62	1.67	1.71	
			$T_A = -40^\circ\text{C}$ to $+125^\circ\text{C}$	1.61	1.67	1.72	
MAX68__V	$T_A = -40^\circ\text{C}$ to $+85^\circ\text{C}$	1.52	1.58	1.62			

Electrical Characteristics (continued)

($V_{CC} = +4.5V$ to $+5.5V$ for MAX68__L/M, $V_{CC} = +2.7V$ to $+3.6V$ for MAX68__T/S/R, $V_{CC} = +2.1V$ to $+2.75V$ for MAX68__Z/Y, $V_{CC} = +1.53V$ to $+2.0V$ for MAX68__W/V; $T_A = -40^\circ C$ to $+125^\circ C$, unless otherwise specified. Typical values are at $T_A = +25^\circ C$.) (Note 1)

PARAMETER	SYMBOL	CONDITIONS		MIN	TYP	MAX	UNITS
V_{CC2} Reset Threshold	V_{TH2}	Z	$T_A = -40^\circ C$ to $+85^\circ C$	2.244	2.313	2.381	V
			$T_A = -40^\circ C$ to $+125^\circ C$	2.238	2.313	2.388	
		Y	$T_A = -40^\circ C$ to $+85^\circ C$	2.119	2.188	2.257	
			$T_A = -40^\circ C$ to $+125^\circ C$	2.113	2.188	2.263	
		W	$T_A = -40^\circ C$ to $+85^\circ C$	1.615	1.665	1.715	
			$T_A = -40^\circ C$ to $+125^\circ C$	1.611	1.665	1.719	
		V	$T_A = -40^\circ C$ to $+85^\circ C$	1.525	1.575	1.625	
			$T_A = -40^\circ C$ to $+125^\circ C$	1.521	1.575	1.629	
		I	$T_A = -40^\circ C$ to $+85^\circ C$	1.346	1.388	1.429	
			$T_A = -40^\circ C$ to $+125^\circ C$	1.343	1.388	1.433	
		H	$T_A = -40^\circ C$ to $+85^\circ C$	1.271	1.313	1.354	
			$T_A = -40^\circ C$ to $+125^\circ C$	1.268	1.313	1.358	
		G	$T_A = -40^\circ C$ to $+85^\circ C$	1.077	1.110	1.143	
			$T_A = -40^\circ C$ to $+125^\circ C$	1.074	1.110	1.146	
		F	$T_A = -40^\circ C$ to $+85^\circ C$	1.017	1.050	1.083	
			$T_A = -40^\circ C$ to $+125^\circ C$	1.014	1.050	1.086	
		E	$T_A = -40^\circ C$ to $+85^\circ C$	0.808	0.833	0.858	
			$T_A = -40^\circ C$ to $+125^\circ C$	0.806	0.833	0.860	
D	$T_A = -40^\circ C$ to $+85^\circ C$	0.762	0.788	0.813			
	$T_A = -40^\circ C$ to $+125^\circ C$	0.761	0.788	0.815			
Reset Threshold Temperature Coefficient				60			ppm/ $^\circ C$
Reset Threshold Hysteresis				2 x V_{TH}			mV
RESET IN Threshold	$V_{RSTINTH}$	$V_{RSTINTH}$ falling	$T_A = 0^\circ C$ to $+85^\circ C$	0.615	0.630	0.645	V
			$T_A = -40^\circ C$ to $+125^\circ C$	0.610		0.650	
RESET IN Hysteresis				2.5			mV
RESET IN Input Current (Note 2)	I_{RSTIN}		$T_A = -40^\circ C$ to $+85^\circ C$	-25		+25	nA
			$T_A = -40^\circ C$ to $+125^\circ C$	-100		+100	
V_{CC} to Reset Output Delay	t_{RD}	$V_{CC} = V_{TH}$ to $(V_{TH} - 100mV)$		20			μs
RESET IN to Reset Output Delay		$V_{RSTIN} = V_{RSTINTH}$ to $(V_{RSTINTH} - 30mV)$		15			μs
Reset Timeout Period	t_{RP}	$T_A = -40^\circ C$ to $+85^\circ C$		140	200	280	ms
		$T_A = -40^\circ C$ to $+125^\circ C$		100		320	
\overline{RESET} Output LOW (Push-Pull or Open-Drain)	V_{OL}	$V_{CC} \geq 1.0V$, $I_{SINK} = 50\mu A$, reset asserted, $T_A = 0^\circ C$ to $+85^\circ C$				0.3	V
		$V_{CC} \geq 1.2V$, $I_{SINK} = 100\mu A$, reset asserted				0.3	
		$V_{CC} \geq 2.55V$, $I_{SINK} = 1.2mA$, reset asserted				0.3	
		$V_{CC} \geq 4.25V$, $I_{SINK} = 3.2mA$, reset asserted				0.4	

Electrical Characteristics (continued)

($V_{CC} = +4.5V$ to $+5.5V$ for MAX68__L/M, $V_{CC} = +2.7V$ to $+3.6V$ for MAX68__T/S/R, $V_{CC} = +2.1V$ to $+2.75V$ for MAX68__Z/Y, $V_{CC} = +1.53V$ to $+2.0V$ for MAX68__W/V; $T_A = -40^\circ C$ to $+125^\circ C$, unless otherwise specified. Typical values are at $T_A = +25^\circ C$.) (Note 1)

PARAMETER	SYMBOL	CONDITIONS	MIN	TYP	MAX	UNITS
$\overline{\text{RESET}}$ Output HIGH (Push-Pull Only)	V_{OH}	$V_{CC} \geq 1.8V$, $I_{SOURCE} = 200\mu A$, reset not asserted	$0.8 \times V_{CC}$			V
		$V_{CC} \geq 3.15V$, $I_{SOURCE} = 500\mu A$, reset not asserted	$0.8 \times V_{CC}$			
		$V_{CC} \geq 4.75V$, $I_{SOURCE} = 800\mu A$, reset not asserted	$0.8 \times V_{CC}$			
Open-Drain $\overline{\text{RESET}}$ Output Leakage Current (Note 1)	I_{LKG}	RESET not asserted			1.0	μA
RESET Output HIGH (Push-Pull Only)	V_{OH}	$V_{CC} \geq 1.0V$, $I_{SOURCE} = 1\mu A$, reset asserted, $T_A = 0^\circ C$ to $+85^\circ C$	$0.8 \times V_{CC}$			V
		$V_{CC} \geq 1.50V$, $I_{SOURCE} = 100\mu A$, reset asserted	$0.8 \times V_{CC}$			
		$V_{CC} \geq 2.55V$, $I_{SOURCE} = 500\mu A$, reset asserted	$0.8 \times V_{CC}$			
		$V_{CC} \geq 4.25V$, $I_{SOURCE} = 800\mu A$, reset asserted	$0.8 \times V_{CC}$			
RESET Output LOW (Push-Pull Only)	V_{OH}	$V_{CC} \geq 1.8V$, $I_{SINK} = 500\mu A$, reset asserted			0.3	V
		$V_{CC} \geq 3.15V$, $I_{SINK} = 1.2mA$, reset asserted			0.3	
		$V_{CC} \geq 4.75V$, $I_{SINK} = 3.2mA$, reset asserted			0.3	
MANUAL RESET INPUT						
$\overline{\text{MR}}$ Input voltage	V_{IL}				$0.3 \times V_{CC}$	V
	V_{IH}			$0.7 \times V_{CC}$		
$\overline{\text{MR}}$ Minimum Input Pulse			1			μs
$\overline{\text{MR}}$ Glitch Rejection				100		ns
$\overline{\text{MR}}$ to Reset Delay				200		ns
$\overline{\text{MR}}$ Pullup Resistance			25	50	75	k Ω
WATCHDOG INPUT						
Watchdog Timeout Period	t_{WD}	$T_A = -40^\circ C$ to $+85^\circ C$	1.12	1.6	2.4	s
		$T_A = -40^\circ C$ to $+125^\circ C$	0.80		2.60	
WDI Pulse Width (Note 2)	t_{WDI}		50			ns
WDI Input Voltage	V_{IL}				$0.3 \times V_{CC}$	V
	V_{IH}		$0.7 \times V_{CC}$			
WDI Input Current	I_{WDI}	WDI = V_{CC} , time average		120	160	μA
		WDI = 0, time average	-20	-15		

Note 1: Over-temperature limits are guaranteed by design and not production tested. Devices tested at $+25^\circ C$.

Note 2: Guaranteed by design and not production tested.

Typical Operating Characteristics

(TA = +25°C, unless otherwise noted.)

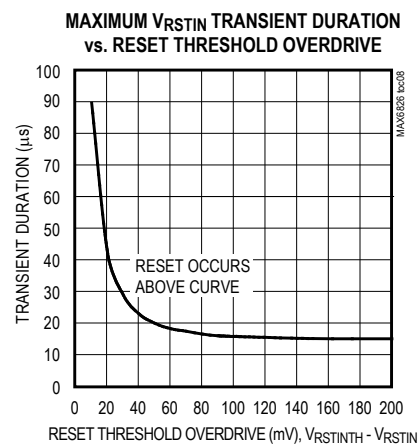
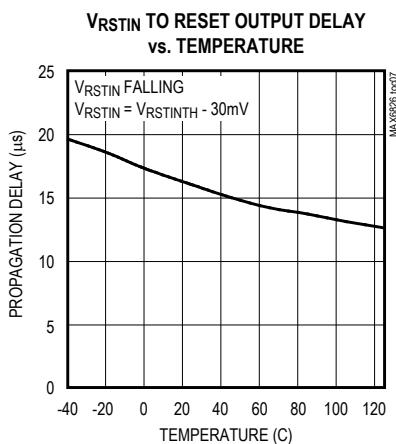
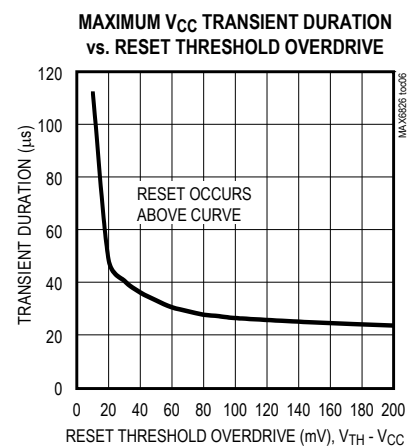
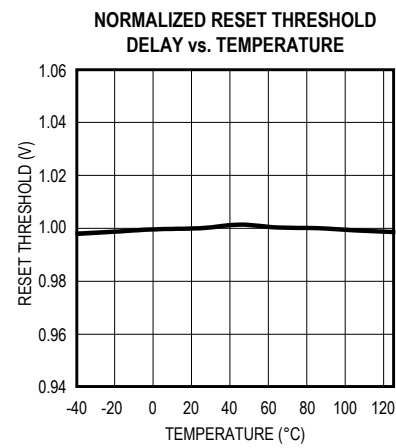
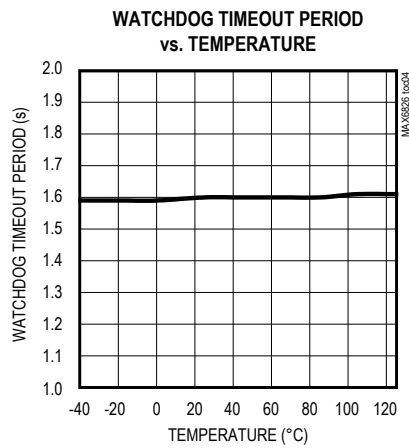
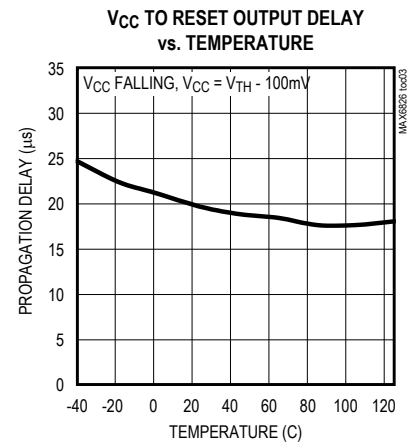
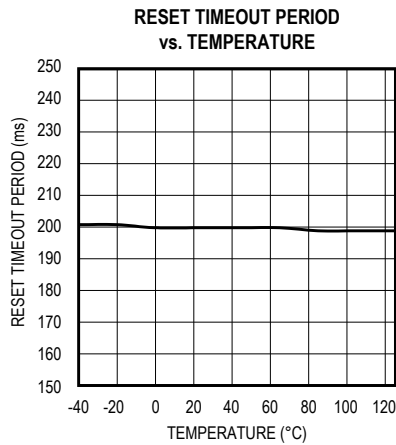
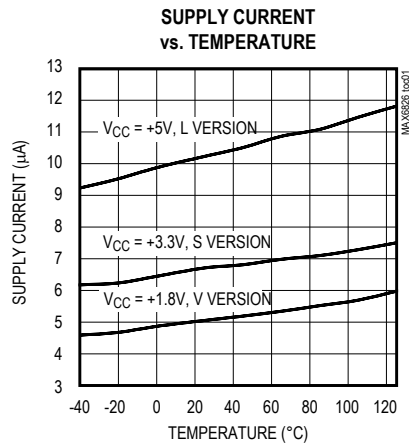

Typical Operating Characteristics (continued)

(TA = +25°C, unless otherwise noted.)

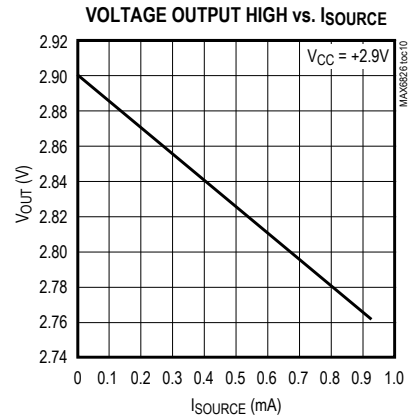
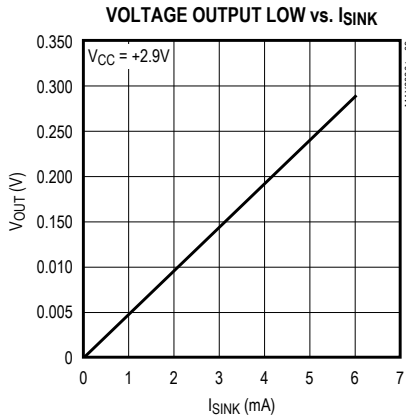

Pin Description

PIN						NAME	FUNCTION
MAX 6826	MAX 6827	MAX 6828	MAX 6829	MAX 6830	MAX 6831		
1		1	1		1	\overline{RESET}	Active-Low Open-Drain or Push-Pull Reset Output. \overline{RESET} changes from high to low when V_{CC1} , V_{CC2} , or $RESET\ IN$ input drops below the selected reset threshold, \overline{MR} is pulled low, or the watchdog triggers a reset. \overline{RESET} remains low for the reset timeout period after all voltages exceed the device reset threshold, \overline{MR} goes low to high, or the watchdog triggers a reset.
	1			1		RESET	Active-High Push-Pull Reset Output. RESET changes from low to high when V_{CC1} , V_{CC2} , or $RESET\ IN$ input drops below the selected reset threshold, \overline{MR} is pulled low, or the watchdog triggers a reset. RESET remains HIGH for the reset timeout period after all voltages exceed the device reset threshold, \overline{MR} goes low to high, or the watchdog triggers a reset.
2	2	2	2	2	2	GND	Ground
3	3	3	3	3	3	\overline{MR}	Manual-Reset Input, Active-Low, Internal 50k Ω pullup to VCC. Pull low to force a reset. Reset remains active as long as \overline{MR} is low and for the reset timeout period after \overline{MR} goes high. Leave unconnected or connect to VCC, if unused.
4	4	4	4	4	4	WDI	Watchdog Input. If WDI remains high or low for longer than the watchdog timeout period, the internal watchdog timer runs out and a reset is triggered for the reset timeout period. The internal watchdog timer clears whenever reset is asserted, the manual reset is asserted, or WDI sees a rising or falling edge. If WDI is left unconnected or is connected to a three-stated buffer output, the watchdog feature is disabled.

Pin Description (continued)

PIN						NAME	FUNCTION
MAX 6826	MAX 6827	MAX 6828	MAX 6829	MAX 6830	MAX 6831		
5	5	5				RESET IN	Input for User-Adjustable RESET IN Monitor. High-impedance input for internal reset comparator. Connect this pin to an external resistor-divider network to set the reset threshold voltage. 0.63V (typ) threshold.
			5	5	5	VCC2	Factory-Trimmed VCC2 Monitor. Connect this pin to a secondary power-supply voltage.
6	6	6	6	6	6	VCC	Supply Voltage. Input for primary reset threshold monitor.

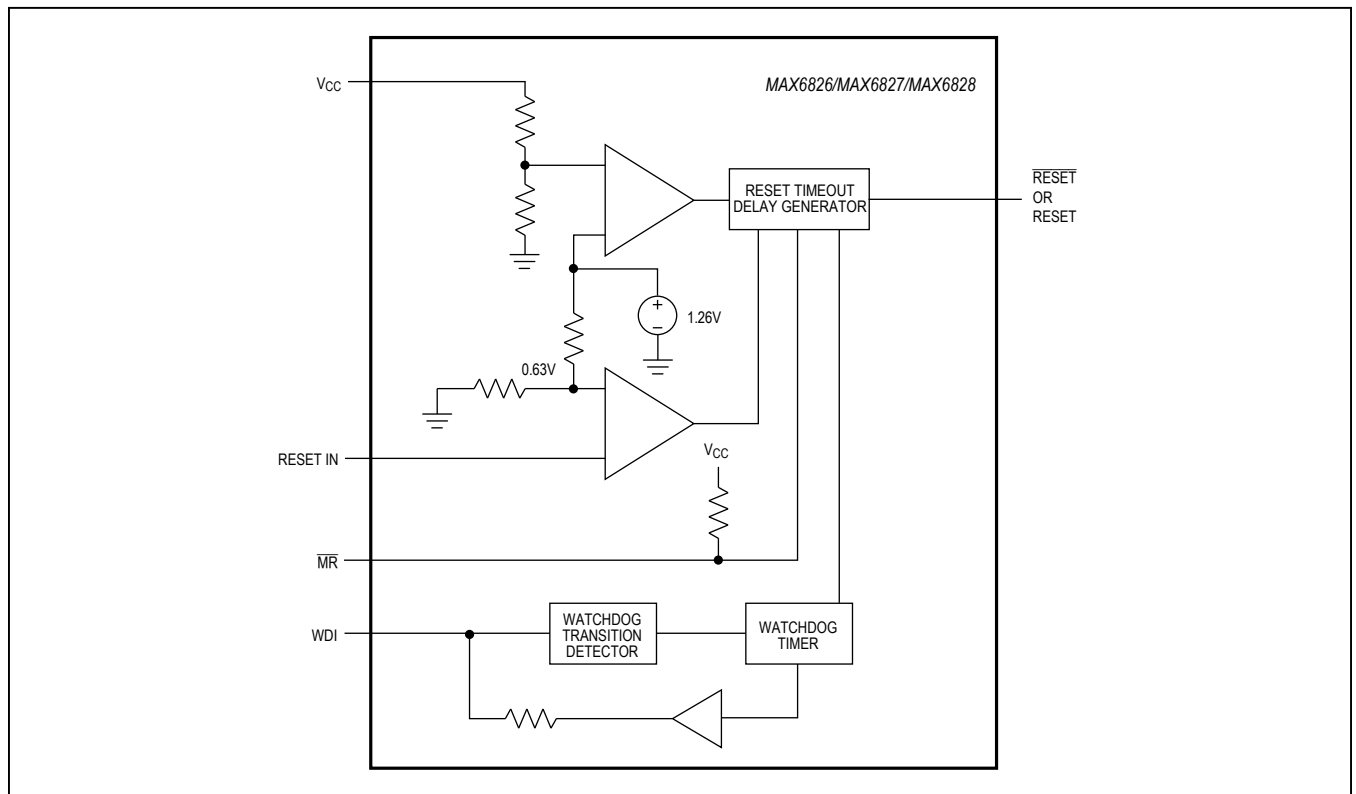

Figure 1. Functional Diagram of RESET IN

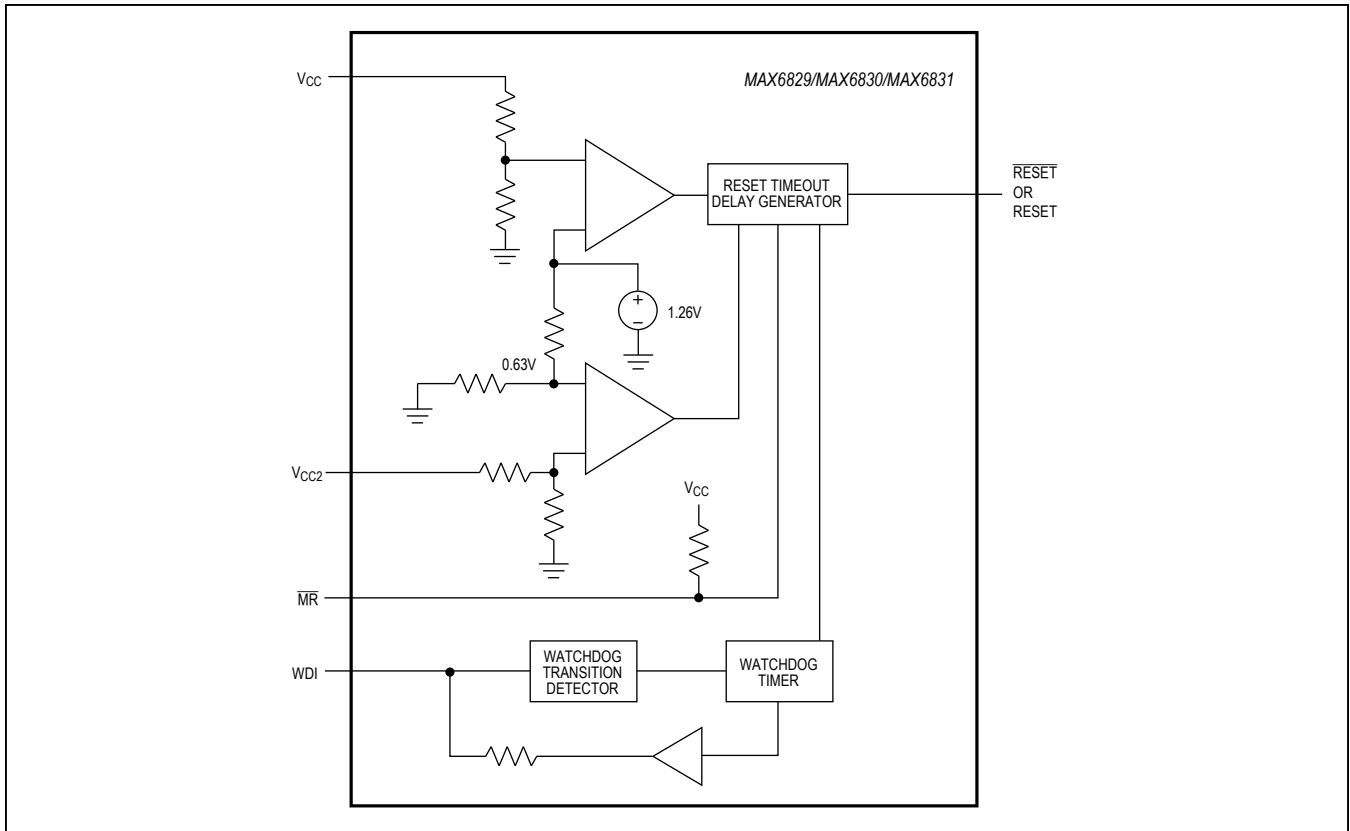

Figure 2. Functional Diagram of V_{CC2}

Detailed Description

RESET/RESET Output

A microprocessor's (μ P's) reset input starts the μ P in a known state. The MAX6826–MAX6831 μ P supervisory circuits assert a reset to prevent code-execution errors during power-up, power-down, and brownout conditions. Whenever a monitored voltage falls below the reset threshold, the reset output asserts low for RESET and high for RESET. Once all monitored voltages exceed their reset thresholds, an internal timer keeps the reset output asserted for the specified reset timeout period (t_{RP}); after this interval, reset output returns to its original state (Figure 3).

Manual-Reset Input

Many μ P-based products require manual-reset capability, allowing the operator, a test technician, or external logic circuitry to initiate a reset. A logic low on

$\overline{\text{MR}}$ asserts a reset. Reset remains asserted while $\overline{\text{MR}}$ is low, and for the timeout period (140ms min) after it returns high. $\overline{\text{MR}}$ has an internal 50k Ω pullup resistor, so it can be left open if not used. This input can be driven with CMOS logic levels or with open-drain/collector

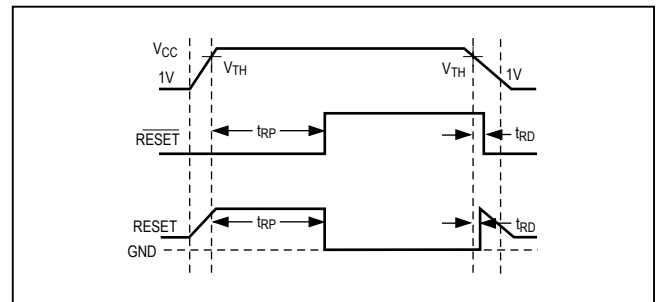

Figure 3. Reset Timing Diagram

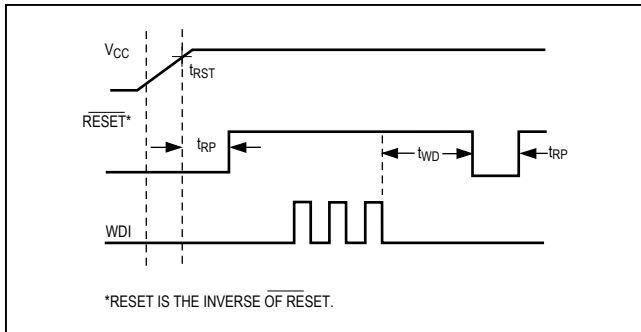

Figure 4. Watchdog Timing Relationship

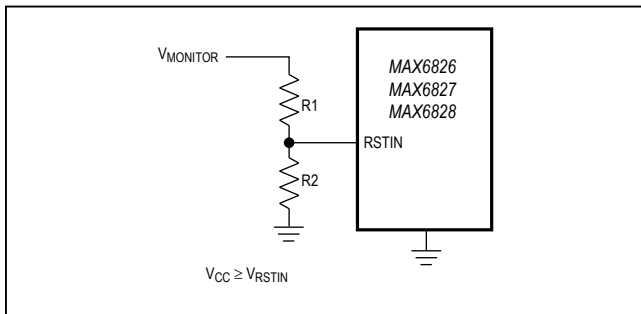

Figure 5. Monitoring a Voltage

outputs. Connect a normally open momentary switch from \overline{MR} to GND to create a manual-reset function; external debounce circuitry is not required. If \overline{MR} is driven from long cables or the device is used in a noisy environment, connect a 0.1 μ F capacitor from \overline{MR} to GND to provide additional noise immunity.

Watchdog Input

The watchdog circuit monitors the μ P's activity. If the μ P does not toggle (low to high or high to low) the watchdog input (WDI) within the watchdog timeout period (1.6s nominal), reset asserts for the reset timeout period. The internal 1.6s timer can be cleared by either a reset pulse or by toggling WDI. The WDI can detect pulses as short as 50ns. While reset is asserted, the timer remains cleared and does not count. As soon as reset is released, the timer starts counting (Figure 4).

Disable the watchdog function by leaving WDI unconnected or by three-stating the driver connected to WDI. The watchdog input is internally driven low during the first 7/8 of the watchdog timeout period and high for the last 1/8 of the watchdog timeout period. When WDI is left unconnected, this internal driver clears the 1.6s timer every 1.4s. When WDI is three-stated or unconnected, the maximum allowable leakage current is 10 μ A and the maximum allowable load capacitance is 200pF.

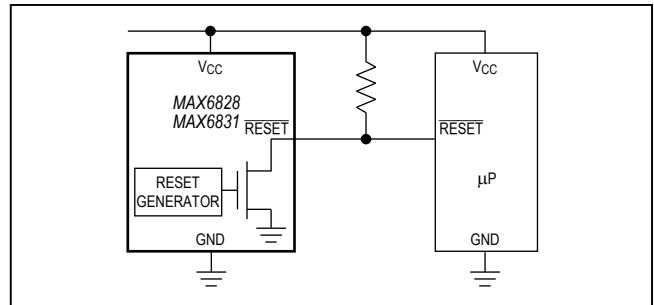

Figure 6. Interfacing Open-Drain \overline{RESET} to μ Ps with Bidirectional Reset I/O

Adjustable Reset Thresholds

The MAX6826/MAX6827/MAX6828 provide a user adjustable input to monitor a second voltage. The threshold voltage at RSTIN is typically 0.63V. To monitor a voltage higher than 0.63V, connect a resistor divider to the circuit as shown in Figure 5. The threshold at $V_{MONITOR}$ is:

$$V_{MONITOR_TRIP} = 0.63V \left(\frac{R1+R2}{R2} \right)$$

Note that RSTIN is powered by V_{CC} , and its voltage must therefore remain lower than V_{CC} .

Applications Information

Watchdog Input Current

The WDI inputs are internally driven through a buffer and series resistor from the watchdog timer (Figure 1). When WDI is left unconnected, the watchdog timer is serviced within the watchdog timeout period by a low-high-low pulse from the counter chain. For minimum watchdog input current (minimum overall power consumption), leave WDI low for the majority of the watch-dog timeout period, pulsing it low-high-low once within the first 7/8 of the watchdog timeout period to reset the watchdog timer. If WDI is externally driven high for the majority of the timeout period, up to 160 μ A can flow into WDI.

Interfacing to μ Ps with Bidirectional Reset Pins

Since the \overline{RESET} output on the MAX6828/MAX6831 is open drain, these devices interface easily with μ Ps that have bidirectional reset pins, such as the Motorola 68HC11. Connecting the μ P supervisor's \overline{RESET} output directly to the microcontroller's \overline{RESET} pin with a single pullup resistor allows the device to assert a reset (Figure 6).

Negative-Going VCC Transients

These supervisors are relatively immune to short-duration, negative-going V_{CC} transients (glitches), which usually do not require the entire system to shut down. Resets are issued to the μ P during power-up, power-down, and brownout conditions. The *Typical Operating Characteristics* show a graph of the Maximum V_{CC} Transient Duration vs. Reset Threshold Overdrive, for which reset pulses are **not** generated. The graph was produced using negative-going V_{CC} pulses, starting at the standard monitored voltage and ending below the reset threshold by the magnitude indicated (reset threshold overdrive). The graph shows the maximum pulse width that a negative-going V_{CC} transient can typically have without triggering a reset pulse. As the amplitude of the transient increases (i.e., goes farther below the reset threshold), the maximum allowable pulse width decreases. Typically, a V_{CC} transient that goes 100mV below the reset threshold and lasts for 20 μ s or less will not trigger a reset pulse.

Ensuring a Valid RESET Output Down to $V_{CC} = 0$

The MAX6826–MAX6831 are guaranteed to operate properly down to $V_{CC} = 1V$. In applications that require valid reset levels down to $V_{CC} = 0$, a pulldown resistor to active-low outputs (push/pull only, Figure 7) and a pullup resistor to active-high outputs (push/pull only) will ensure that the reset line is valid while the reset output can no longer sink or source current. This scheme does not work with the open-drain outputs of the MAX6828/MAX6831. The resistor value used is not critical, but it must be small enough not to load the reset output when V_{CC} is above the reset threshold. For falling slew rates greater than 1V/s, a 100k Ω is adequate.

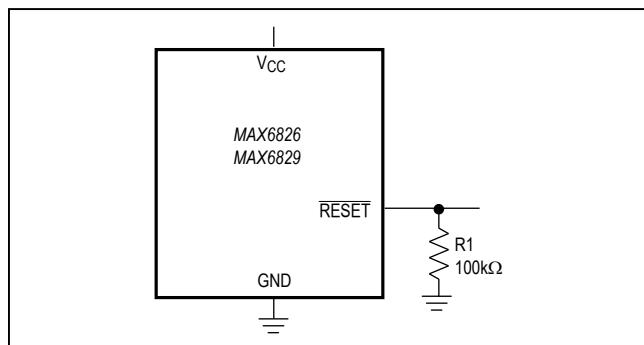

Figure 7. RESET Valid to $V_{CC} = \text{Ground}$ Circuit

Watchdog Software Considerations

One way to help the watchdog timer monitor software execution more closely is to set and reset the watchdog input at different points in the program, rather than pulsing the watchdog input high-low-high or low-high-low. This technique avoids a stuck loop, in which the watchdog timer would continue to be reset inside the loop, keeping the watchdog from timing out.

Figure 8 shows an example of a flow diagram where the I/O driving the watchdog input is set high at the beginning of the program, set low at the beginning of every subroutine or loop, then set high again when the program returns to the beginning. If the program should hang in any subroutine, the problem would quickly be corrected, since the I/O is continually set low and the watchdog timer is allowed to time out, causing a reset or interrupt to be issued. As described in the *Watchdog Input Current* section, this scheme results in higher time average WDI input current than does leaving WDI low for the majority of the timeout period and periodically pulsing it low-high-low.

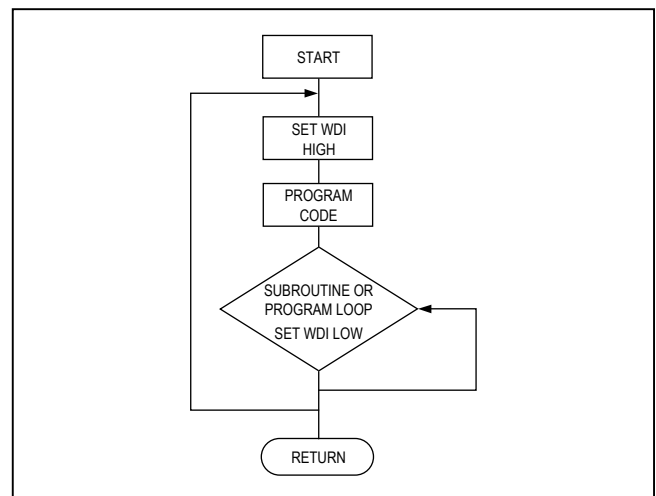

Figure 8. Watchdog Flow Diagram

Threshold Suffix Guide

V _{CC} THRESHOLD	RESET THRESHOLD (V)	V _{CC2} THRESHOLD	RESET THRESHOLD (V)
L	4.63	Z	2.313
M	4.38	Y	2.188
T	3.08	W	1.665
S	2.93	V	1.575
R	2.63	I	1.388
Z	2.32	H	1.313
Y	2.19	G	1.110
W	1.67	F	1.050
V	1.58	E	0.833
		D	0.788

Selector Guide

FUNCTION	ACTIVE-LOW RESET	ACTIVE-HIGH RESET	OPEN-DRAIN RESET	WATCHDOG INPUT	MANUAL RESET INPUT	FIXED V _{CC2} MONITOR	ADJUSTABLE RESET INPUT
MAX6826	✓	—	—	✓	✓	—	✓
MAX6827	—	✓	—	✓	✓	—	✓
MAX6828	—	—	✓	✓	✓	—	✓
MAX6829	✓	—	—	✓	✓	✓	—
MAX6830	—	✓	—	✓	✓	✓	—
MAX6831	—	—	✓	✓	✓	✓	—

Standard Versions Table* (continued)

MAX6829/MAX6830/MAX6831			
	V _{CC}		V _{CC2}
3.3V	2.5V	1.8V	—
TZ	—	—	2.5V
SV	ZW	—	1.8V
SH	YH	WI	1.5V
SF	YG	VF	1.2V
SD	YD	VD	0.9V

*Samples are typically available for standard versions only. For the MAX6829/MAX6830/MAX6831, standard versions require a 2.5k minimum order increment, while nonstandard versions require a 10k minimum order increment and are not typically available in samples. Contact factory for availability.

Typical Operating Circuit

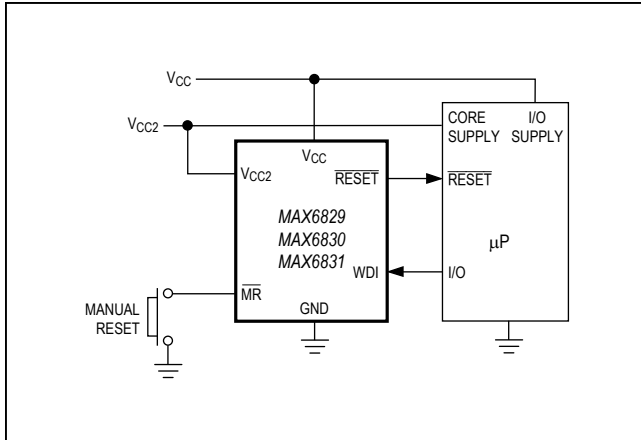

Chip Information

TRANSISTOR COUNT: 750
 PROCESS TECHNOLOGY: BiCMOS

Package Information

For the latest package outline information and land patterns (footprints), go to www.maximintegrated.com/packages. Note that a "+", "#", or "-" in the package code indicates RoHS status only. Package drawings may show a different suffix character, but the drawing pertains to the package regardless of RoHS status.

PACKAGE TYPE	PACKAGE CODE	OUTLINE NO.	LAND PATTERN NO.
6 SOT	U6+1	21-0058	90-0175

Revision History

REVISION NUMBER	REVISION DATE	DESCRIPTION	PAGES CHANGED
3	7/14	No IV OPNs; removed Automotive reference from <i>Applications</i> section	1

For pricing, delivery, and ordering information, please contact Maxim Direct at 1-888-629-4642, or visit Maxim Integrated's website at www.maximintegrated.com.

Maxim Integrated cannot assume responsibility for use of any circuitry other than circuitry entirely embodied in a Maxim Integrated product. No circuit patent licenses are implied. Maxim Integrated reserves the right to change the circuitry and specifications without notice at any time. The parametric values (min and max limits) shown in the Electrical Characteristics table are guaranteed. Other parametric values quoted in this data sheet are provided for guidance.