

REVISIONS					
P	LTR	DESCRIPTION	DATE	DMN	APVD
V	REVISED PER	ECO-16-005380	7APR2016	DS	SY

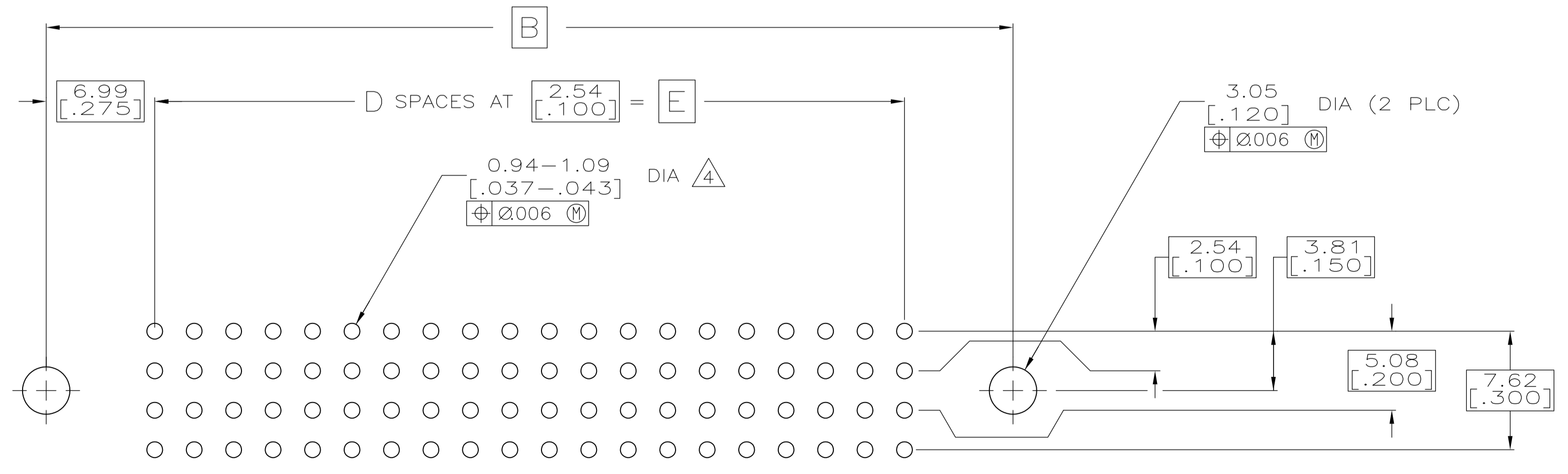
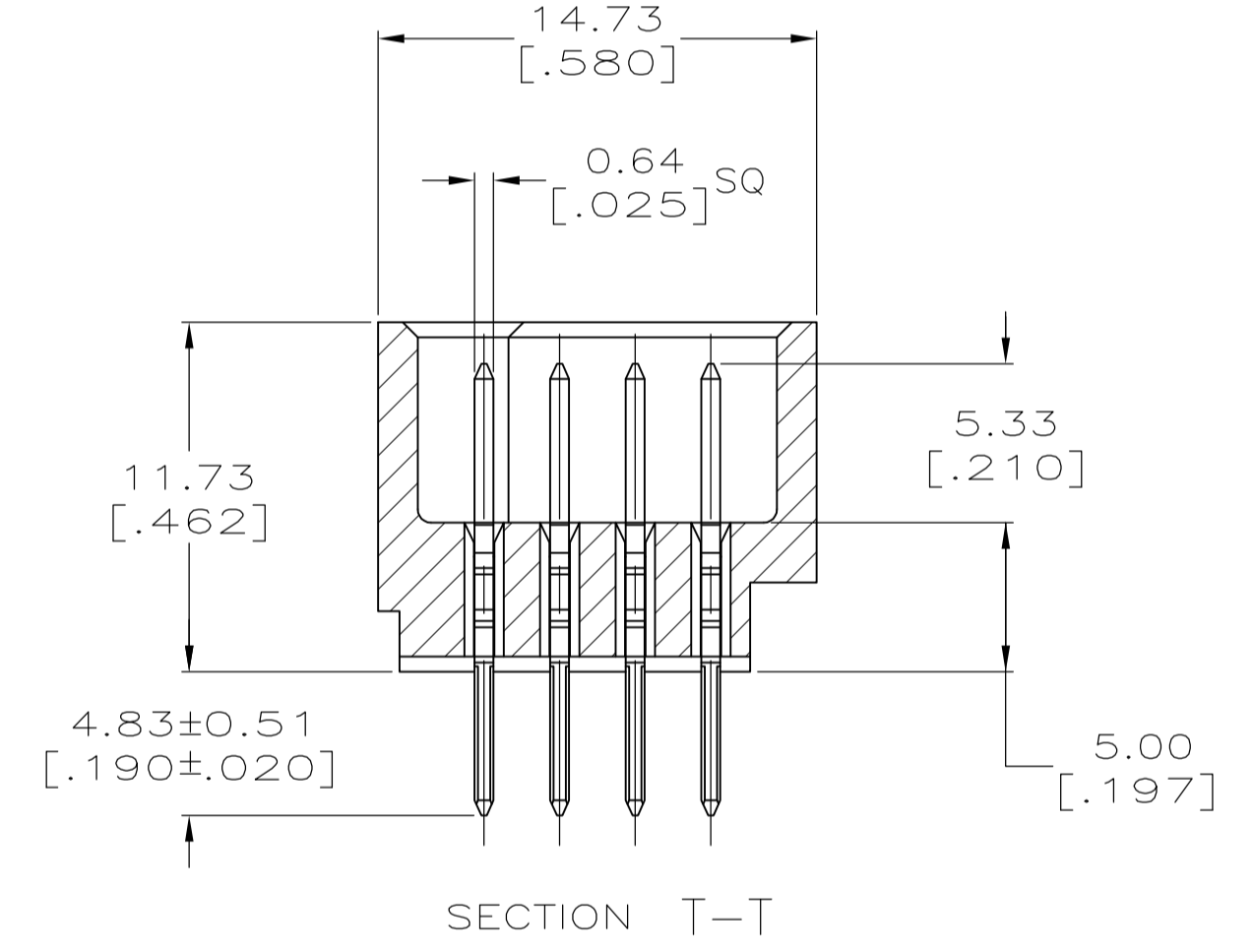
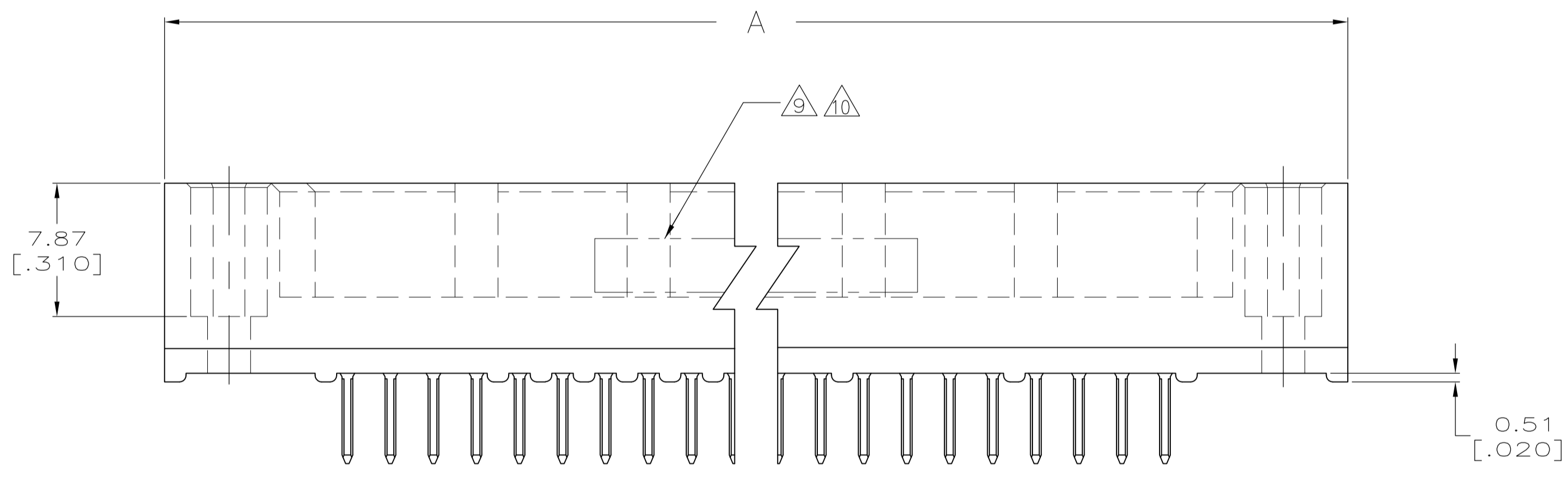
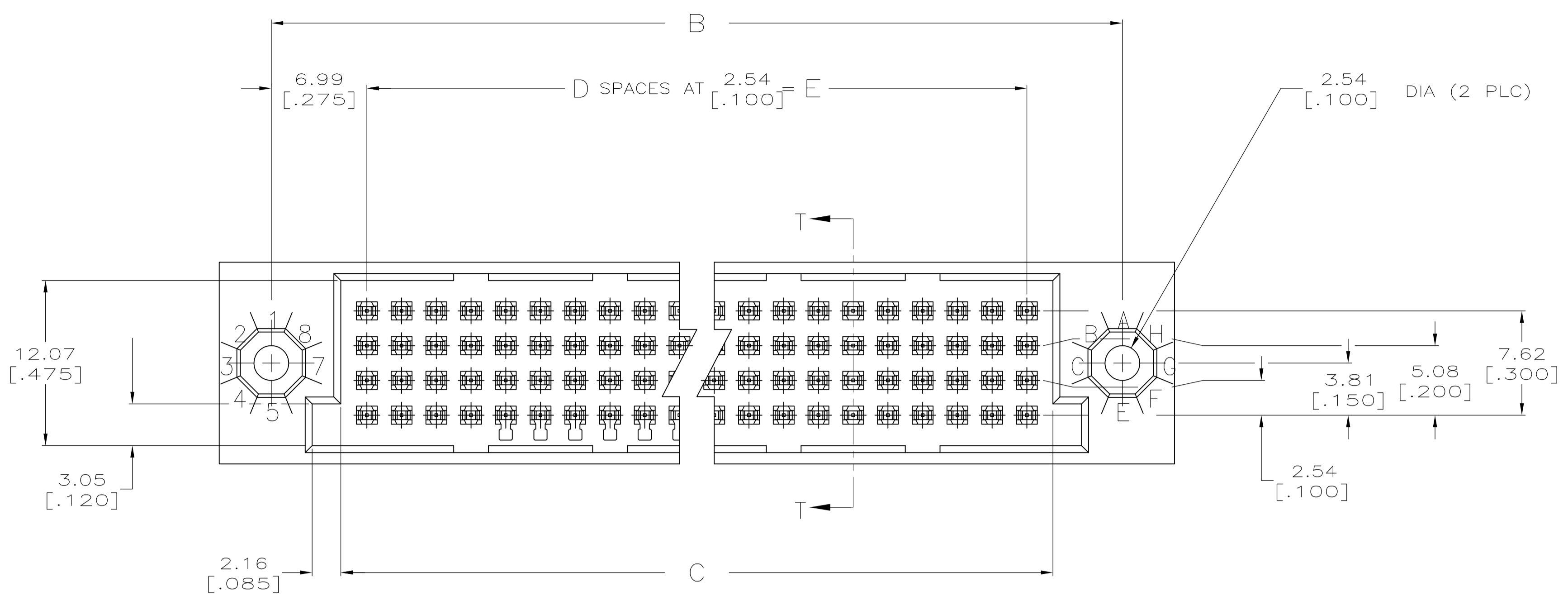

RECOMMENDED P.C. BOARD LAYOUT

THIS DRAWING IS A CONTROLLED DOCUMENT.		DIN R.K. SEIFRIED 04/09/90	TE Connectivity	
DIMENSIONS: mm [INCHES]		CHK F. KIBLER 8-18-92		
TOLERANCES UNLESS OTHERWISE SPECIFIED:		APVD	NAME	
0 PLC ± -			HDI, 4 ROW, PIN ASSEMBLY, 4.83 [.190] LONG SOLDER PINS	
1 PLC ± -			PRODUCT SPEC	
2 PLC ± -			APPLICATION SPEC	
3 PLC ± 0.13 [.005]			SIZE CAGE CODE DRAWING NO	
4 PLC ± -			RESTRICTED TO	
ANGLES ± -			WEIGHT 0 A1 00779 C=532436	
MATERIAL	FINISH	CUSTOMER DRAWING		SCALE 4:1 SHEET 1 OF 2 REV V

REVISIONS				
P	LTR	DESCRIPTION	DATE	APPV
-		SEE SHEET 1	-	-

- 1 HOUSING MATERIAL: THERMOPLASTIC, COLOR-BLACK.
- 2 CONTACT MATERIAL: PHOSPHOR BRONZE.
- 3 FINISH:
MATING AREA: MEETS THE PERFORMANCE REQUIREMENTS OF PRODUCT SPECIFICATION 108-9063; BASED ON TELCORDIA DR-1217-CORE APPLICATIONS IN UNCONTROLLED ENVIRONMENTS.
SOLDER TAILS AREA: TIN-LEAD PLATED.
- 4 SOLDER PIN POST RECOMMENDED P.C. BOARD HOLE SIZES ARE 0.94-1.09 [.037-.043]; RECOMMENDED PAD DIA IS 1.52 [.060].
- 5. DIMENSIONS IN BRACKETS ARE IN INCHES.
- 6 HOUSINGS WITH CENTER MOUNTING IS RECOMMENDED FOR ASSEMBLIES HAVING 75 CONTACTS PER ROW OR MORE.
- 7 PART NUMBER IS OBSOLETE.
- 8 NO CONTACT LUBRICANT
- 9 AMP, PART NUMBER, AND DATE CODE
- 10 OEFD0-983-9000-045, REV A, 00779 AND DATE CODE, ONLY FOR PART NUMBER 2-532436-0
- 11 PART NUMBER IS FOR ROCKWELL COLLINS.
- 12 FINISH:
CONTACT FINISH: .00127-.00254 [.000050-.000100] NICKEL UNDERPLATE ALL OVER; .000762 [.000030] GOLD PLATE IN CONTACT AREA, TIN-LEAD PLATED POSTS.

12	11	10	8	73.66 [2.900]	29	77.47 [3.050]	87.63 [3.450]	95.25 [3.750]	120	2-532436-0
6	6									1-532436-9
										1-532436-8
6	6									1-532436-7
6	6									1-532436-6
6	6									1-532436-5
6	6									1-532436-4
6	6			200.66 [7.900]	79	204.47 [8.050]	214.63 [8.450]	222.25 [8.750]	320	1-532436-3
				187.96 [7.400]	74	191.77 [7.550]	201.93 [7.950]	209.55 [8.250]	300	1-532436-2
				175.26 [6.900]	69	179.07 [7.050]	189.23 [7.450]	196.85 [7.750]	280	1-532436-1
				162.56 [6.400]	64	166.37 [6.550]	176.53 [6.950]	184.15 [7.250]	260	1-532436-0
				149.86 [5.900]	59	153.67 [6.050]	163.83 [6.450]	171.45 [6.750]	240	532436-9
				137.16 [5.400]	54	140.97 [5.550]	151.13 [5.950]	158.75 [6.250]	220	532436-8
				124.46 [4.900]	49	128.27 [5.050]	138.43 [5.450]	146.05 [5.750]	200	532436-7
				111.76 [4.400]	44	115.57 [4.550]	125.73 [4.950]	133.35 [5.250]	180	532436-6
				99.06 [3.900]	39	102.87 [4.050]	113.03 [4.450]	120.65 [4.750]	160	532436-5
				86.36 [3.400]	34	90.17 [3.550]	100.33 [3.950]	107.95 [4.250]	140	532436-4
				78.74 [3.100]	31	82.55 [3.250]	92.71 [3.650]	100.33 [3.950]	128	532436-3
				73.66 [2.900]	29	77.47 [3.050]	87.63 [3.450]	95.25 [3.750]	120	532436-2
				60.96 [2.400]	24	64.77 [2.550]	74.93 [2.950]	82.55 [3.250]	100	532436-1
				E	D	C	B	A	POSN	PART NUMBER

THIS DRAWING IS A CONTROLLED DOCUMENT.		DIN R. K. SEIFRIED 04/09/90 CHK F. KIBLER 8-18-92		 TE Connectivity	
DIMENSIONS: mm [INCHES]		TOLERANCES UNLESS OTHERWISE SPECIFIED:		NAME HDI, 4 ROW, PIN ASSEMBLY, 4.83 [1.90] LONG SOLDER PINS	
0 PLC ± - 1 PLC ± - 2 PLC ± - 3 PLC ± 0.13 [.005] 4 PLC ± - ANGLES ± -		PRODUCT SPEC - APPLICATION SPEC -		SIZE CASE CODE DRAWING NO. RESTRICTED TO	
MATERIAL 1 2		FINISH 3 12		WEIGHT - A 1 00779 C=532436	
CUSTOMER DRAWING				SCALE 4:1 SHEET 2 OF 2 REV V	