



Low Cost ±5 g Dual-Axis Accelerometer with SPI Interface

Automotive Grade

MXP7205VW

FEATURES

- Dual axis accelerometer fabricated on a single CMOS IC
- Monolithic design with mixed mode signal processing
- Zero-g temperature stability better than ±30mg from -40C to 105C
- Sensitivity temperature compensation better that ±3% from -40C to 105C
- ± 5g dynamic range, 800LSB/g sensitivity
- 29Hz bandwidth
- On Demand Self Test
- >50,000 g shock survival rating
- 4.50V to 5.25V single supply operation
- Small surface mount package, 5.5mm x 5.5mm x 2.7mm
- XZ or XY mounting
- RoHS compliant

AUTOMOTIVE APPLICATIONS

- Vehicle Stability Control
- Roll Over Detection
- Electronic Parking Break – Hill Start Assist
- Headlight Leveling and Steering

GENERAL DESCRIPTION

The MXP7205VW is a low cost, dual axis accelerometer built on a standard, submicron CMOS process. It measures acceleration with a full-scale range of ±5g and a sensitivity of 800LSB/g with 14bits operation mode and 50LSB/g with 10bits operation mode.

The MXP7205VW provides an SPI interface.

The typical noise floor is $0.6\text{mg} / \sqrt{\text{Hz}}$, allowing signals below 1mg to be resolved at 1Hz bandwidth. The inherent 3dB roll off of the device is 29Hz providing immunity to and attenuation of higher frequency vibrations present in automotive applications.

The MXP7205VW is packaged in a hermetically sealed LCC surface mount package (5.5 mm x 5.5 mm x 2.7 mm height), and the package can be used for either XY and XZ sensing, its operation temperature is -40°C to +105°C.

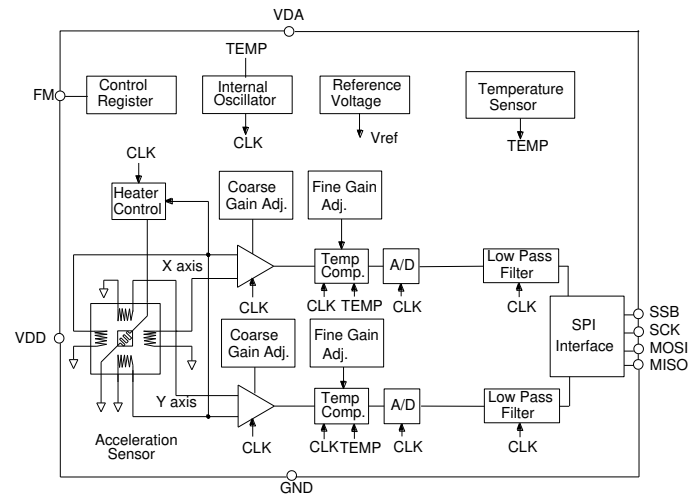

MXP7205VW FUNCTIONAL BLOCK DIAGRAM

MEMSIC’s accelerometer technology allows for designs from ±1 g to ±70 g with custom versions available above ±70 g. It can measure both dynamic acceleration (e.g., vibration) and static acceleration (e.g., gravity).

The design is based on heat convection and requires no solid proof mass. This eliminates stiction, particle, and inherent resonant frequency problems associated with competitive devices and provides shock survivability to greater than 50,000g, leading to significantly lower failure rates and lower loss due to handling during assembly and at customer field application.

Due to the standard CMOS structure of the MXP7205VW, additional circuitry can easily be incorporated into custom versions for high volume applications. Contact MEMSIC’s local office for more information.

Information furnished by MEMSIC is believed to be accurate and reliable. However, no responsibility is assumed by MEMSIC for its use, nor for any infringements of patents or other rights of third parties, which may result from its use. No license is granted by implication or otherwise under any patent or patent rights of MEMSIC.

MXP7205VW SPECIFICATIONS (Measurements @ 25°C, 14bits operation mode, Acceleration = 0 g unless otherwise noted; $V_{DD} = V_{DA} = 5.0V$ unless otherwise specified)

PARAMETER	Conditions	MIN	TYP	MAX	UNITS
Full scale ranges		-5		5	g
Nominal Sensitivity	14bits operation mode		800		LSB/g
	10bits operation mode		50		LSB/g
Initial @ 25°C		-3	0	+3	%
Sensitivity drift	Initial -40°C to +105°C	-3		+3	%
Sensitivity drift	Include Aging -40°C to +105°C	-4	0	+4	%
Cross Axis Sensitivity				2.0	%
Non-Linearity (best straight line)	FSR=10g			1.0	%FSR
Zero g Output Offset	2's complement output		0		LSB
Initial @ 25°C		-60	0	+60	mg
Zero g Output Temperature Drift	Initial -40°C to +105°C	-30		+30	mg
				1.0	mg/°C
Zero g Output Temperature Drift	Include Aging -40°C to +105°C	-60	0	+60	mg
Total Offset Drift Due to Temperature ¹	-40°C to +105°C with 2.5°C/min Temp Ramp (max-min)			80	mg
	-20°C to +80°C with 2.5°C/min Temp Ramp (max-min)			40	mg
	0°C to +60°C with 2.5°C/min Temp Ramp (max-min)			50	mg
Selftest Signal	X-axis		+2.5		g
	Y/Z-axis		-2.5		g
Selftest Signal Tolerance	25°C	-5		+5	%
Selftest Signal Drift (0g input)	-40°C to +105°C	-5		+5	%
	-40°C to +105°C, include aging	-8		+8	%
Selftest Signal Rise/Fall Time				20	mS
Frequency Response		26	29	32	Hz
Phase Delay	0 to 1KHz		10	12	mS
Recover Time From Overload Input	10g, 1mS shock			2	mS
	10000g, 0.5mS half sine shock			10	mS
Input Referred Noise Density	-40°C to +105°C, within 29Hz		0.5	1.5	mg/sqrtHz
RMS Output Noise	No external filtering, 25°C		3.5	5.5	mg RMS
	No external filtering -40°C to +105°C			11	mg RMS
Power up time ²			200	300	mS
Operation Power Supply Range		4.5	5.0	5.25	V
Power consumption	@5V		3.5	4.5	mA
Operation Temperature Range		-40		105	°C

Note: ¹: Requirements can be met by characterization of 3lots x 30 parts per lot, not 100% test in production.

²: Output settled to within +/-17mg of the final value.

DIGITAL INTERFACE

SYMBOL	PARAMETER	CONDITIONS	MIN	MAX	UNITS
VIH	High Level Input Voltage		0.7 x VDD		V
VIL	Low Level Input Voltage			0.3 x VDD	V
Vhys	Hysteresis (SCK, SSB, DI/MOSI)		0.1	0.4	V
VOH	High Level Output (MISO)	Iout = 0.2mA	VDD-0.4		V
VOL	Low Level Output (MISO)	Iout = -0.5mA		0.4	V
Rin1	Pull-down resistance (SCK, DI/MOSI)		100	200	kΩ
Rin2	Pull-down resistance (FM)		30	50	kΩ
IPU	Pull-up Current (SSB) (SPI mode)	VDD=4.5-5.5V	10	50	μA
CL	Load Capacitance (MISO)			80	pF

SYMBOL	PARAMETER	CONDITIONS	MIN	TYP	MAX	UNITS
	SPI Operating Frequency				8.08	MHz
	Data Register Update Rate			800		KHz
	SPI Communication Startup Time				1	ms
td1	SCK High Time		.5 x td3 - 13			ns
td2	SCK Low Time		.5 x td3 - 13			ns
td3	SCK Period		123.7			ns
tr, tf	SCK Rise/Fall Time	0.1xVDD - 0.9xVDD			13	ns
td4	Data Input (MOSI) Setup Time		37			ns
td5	Data Input (MOSI) Hold Time		49			ns
td6	Data Out (MISO) Access Time				43	ns
td7	Data Out(MISO) Valid After SCK				30	ns
td8	Data Output (MISO) Lag Time		0			ns
td9	Data Output (MISO) Disable Time				750	ns
td10	Enable (SSB) Lead Time		.5 x td3			ns
td11	Enable (SSB) Lag Time		.5 x td3			ns
td12	Sequential Transfer Delay		1.5 x td3			ns

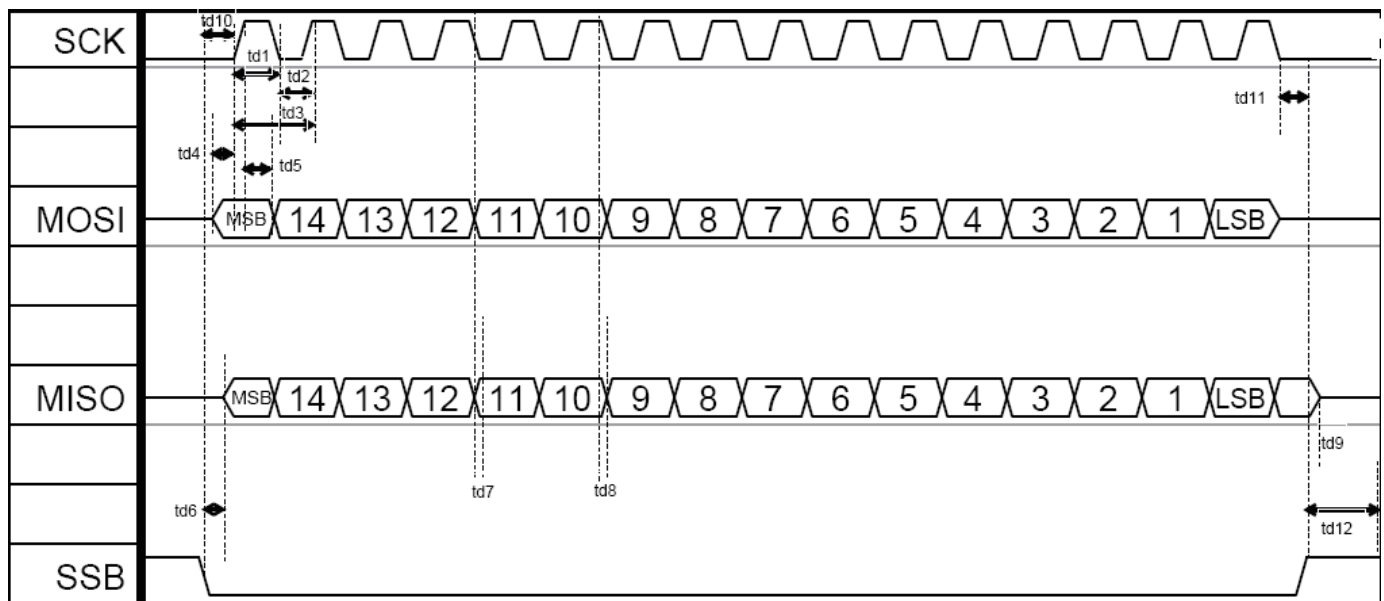

SPI Timing

ABSOLUTE MAXIMUM RATINGS*

Supply Voltage (V_{DD} , V_{DA})¹-0.5 to +7.0V
 Storage Temperature-55°C to +150°C
 Storage Pressure.....1,378 kPa
 Acceleration (any axis, Un-powered for 0.5 msec)...50,000 g
 Acceleration (any axis, Powered for 0.5 msec)... 10,000 g
 Output Short Circuit Duration, any pin to common.....Indefinite

*Stresses above those listed under Absolute Maximum Ratings may cause permanent damage to the device. This is a stress rating only; the functional operation of the device at these or any other conditions above those indicated in the operational sections of this specification is not implied. Exposure to absolute maximum rating conditions for extended periods may affect device reliability.

¹ Exposure for up to 60 minutes to absolute maximum ratings for supply voltages will not affect device reliability.

Ordering Guide

Model	Package Style
MXP7205VW	LCC-8 SMD*

* Parts are shipped in tape and reel packaging.

Pin Description: LCC Package

Pin	Name	Description
1	MISO	Master In - Slave Out
2	V_{DA}	Analog Supply
3	V_{DD}	Digital Supply, V_{DA} and V_{DD} must be the same voltage
4	FM	Factory mode (for factory test only). Connect to VSS
5/J	SCK	Clock Input
6/M	SSB	Slave Select Bar (active low)
7/L	VSS	Ground
8/K	MOSI	Master Out - Slave In

Caution

ESD (electrostatic discharge) sensitive device.

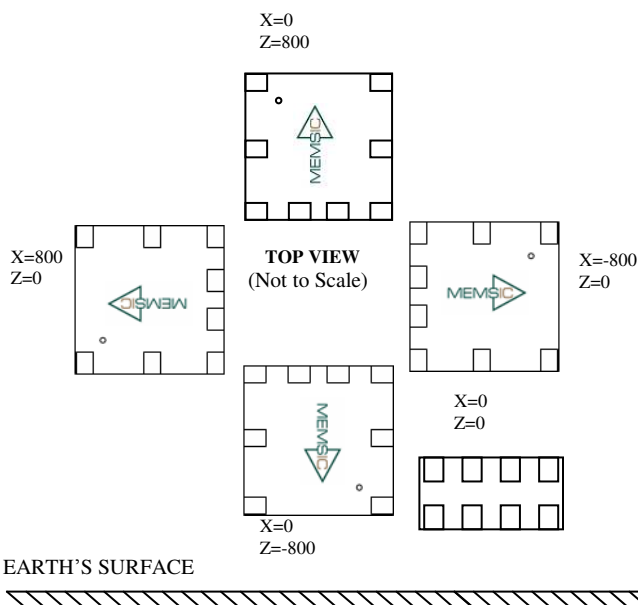

Note: The MEMSIC logo's arrow indicates the +Z sensing direction of the device.
 Small circle indicates pin one (7).

ESD Compliance:

The MXP7205VW sensor is in compliance with the following ESD standards:
 HBM class H2 per AEC-Q100-002 Rev. E
 MM class M2 per AEC-Q100-003 Rev. E

XY Sensing:

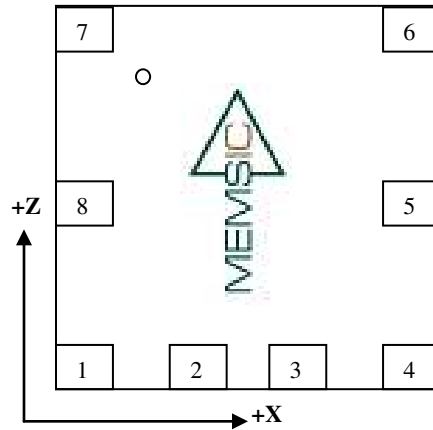

(Top View, do not scale)

Note: Small circle indicates pin seven (7).

XZ Sensing:

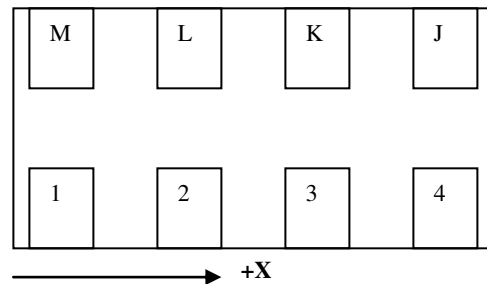

(Bottom View, do not scale)

THEORY OF OPERATION

The MEMSIC device is a complete dual-axis acceleration measurement system fabricated on a monolithic CMOS IC process. The device operation is based on heat transfer by natural convection and operates like other accelerometers having a proof mass except it is a gas in the MEMSIC sensor.

A single heat source, centered in the silicon chip is suspended across a cavity. Equally spaced aluminum/polysilicon thermopiles (groups of thermocouples) are located equidistantly on all four sides of the heat source (dual axis). Under zero acceleration, a temperature gradient is symmetrical about the heat source, so that the temperature is the same at all four thermopiles, causing them to output the same voltage.

Acceleration in any direction will disturb the temperature profile, due to free convection heat transfer, causing it to be asymmetrical. The temperature, and hence voltage output of the four thermopiles will then be different. The differential voltage at the thermopile outputs is directly proportional to the acceleration. There are two identical acceleration signal paths on the MXP7205VF, one to measure acceleration in the x-axis and one to measure acceleration in the y/z-axis. For more details visit the MEMSIC website at www.MEMSIC.com for a picture/graphic description of the free convection heat transfer principle.

PIN DESCRIPTIONS

V_{DD} – This is the digital power supply for the MXP7205VW. This pin supplies current to the heater element and digital circuitry. The DC voltage should be between 4.5V and 5.25V.

V_{DA} – This is the analog power supply. This pin supplies current to the analog circuitry. The DC voltage should be equal to the voltage supplied to the V_{DD} pin.

VSS – This is the ground pin for the MXP7205VW.

FM – Factory Mode for factory use only, connect to VSS.

MISO – This pin serves as the Master In Slave Out (MISO) SPI function. The MISO signal is the serial output data sent from the MXP7205VW to the external SPI controller, such as acceleration output data and status information.

SSB – This pin serves as the Slave Select Bar (SSB) SPI function. When SSB is high, communication with the SPI is disabled; when SSB is low, communication is enabled, and data can be exchanged between the MXP7205VW and the external SPI controller.

MOSI – This pin serves as the Master Out Slave In (MOSI) SPI function. The MOSI signal is the serial input data to the MXP7205VW from the external SPI controller, such as SPI control register load commands or requests for output data.

SCK – This pin is the SPI clock signal and is used to transfer data between the MXP7205VW and an external controller via the MOSI and MISO pins.

SIGNAL PATH FREQUENCY RESPONSE

The frequency response of the MXP7205VW is primarily determined by the thermal sensor characteristics and a digital lowpass filter included in the signal path to eliminate quantization noise and limit thermal noise bandwidth. The sensor is modelled as a two pole lowpass filter, with real poles located nominally at 40 Hz and 85 Hz. The lowpass filter is a second order Butterworth filter with a 3 dB cutoff frequency of nominally 44 Hz. Sensor poles have a tolerance of approximately $\pm 10\%$, and the Butterworth filter cutoff frequency has a tolerance of approximately $\pm 5\%$.

The nominal complex transfer function of the signal path is given by:

$$H(f) = \frac{1}{1 + j\left(\frac{f}{40}\right)} \cdot \frac{1}{1 + j\left(\frac{f}{85}\right)} \cdot \frac{1}{1 - \left(\frac{f}{44}\right)^2 + j\sqrt{2}\left(\frac{f}{44}\right)}$$

Plots of the amplitude (in dB, relative to DC sensitivity) and phase response (in degrees) of the signal path for typical, minimum, and maximum sensor and filter pole frequencies are shown below.

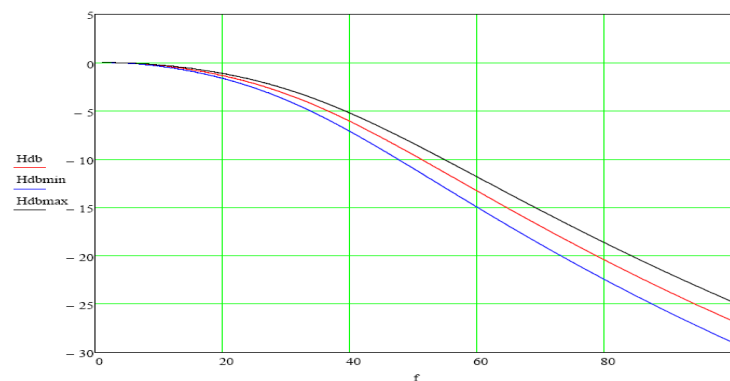

Signal Path Amplitude Response

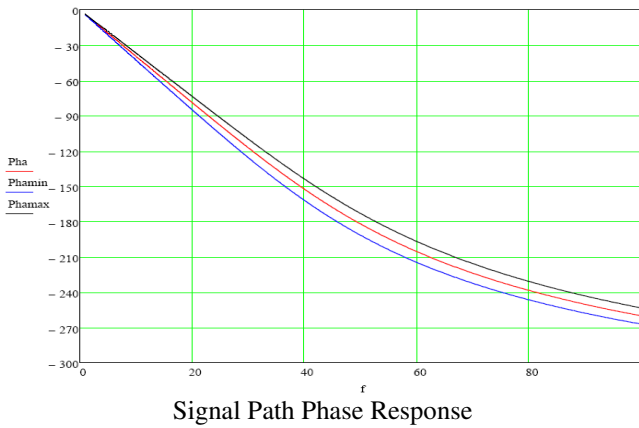

SELF-TEST DESCRIPTION

The gas law governs the change in sensitivity over temperature.

All thermal accelerometers display the same sensitivity change with temperature. The sensitivity change depends on variations in heat transfer that are governed by the laws of physics. Manufacturing variations do not influence the sensitivity change, so there are no unit-to-unit differences in sensitivity change. The sensitivity change is governed by the following equation (and shown in Figure 1 in °C):

$$S_i \times T_i^{2.8} = k \times S_f \times T_f^{2.8}$$

where S_i is the sensitivity at any initial temperature T_i , and S_f is the sensitivity at any other final temperature T_f with the temperature values in °C, k is the ratio between uncompensated sensitivity and compensated sensitivity at 25°C.

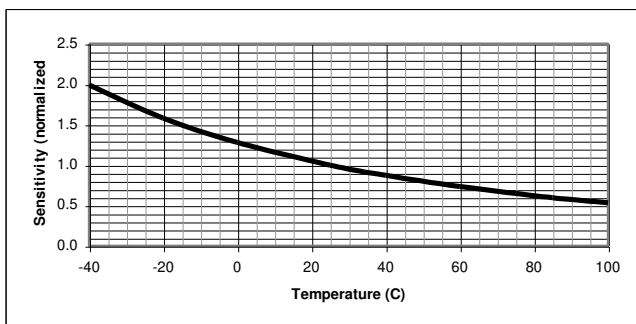

Thermal Accelerometer Sensitivity

A SPI function has been included for digital serial communication with an external host microprocessor. The device includes a control register for activating various operating and test modes. This control register includes a TC bit and an ST bit, which can be written via the SPI port. Setting TC=1 disables the TC function; setting ST=1 activates the ST function. The ability to control the TC and ST functions independently provides a significant

advantage in generating and measuring an accurate ST signal.

Note: ST means Self Test, TC means Temperature Compensation

The recommended method for verifying ST amplitude is as follows:

1. Set the control register bit TC=1 to disable TC.
2. Read acceleration output on the desired channel(s) (read through the SPI port) -- call this Out1.
3. Set control bit ST=1, leaving TC=1, which disables TC and activates ST.
4. Read acceleration output on the same channel(s) -- call this Out2.
5. Subtract (Out2—Out1). This is the ST signal amplitude.
6. Set ST=0 and TC=0, returning the accelerometer to normal mode.

Using the above method, the presence of a real constant acceleration stimulus does not affect the ST amplitude, provided that the acceleration plus self-test signal is not so large that the signal path is saturated.

Note1: When the temperature compensation is disabled and self-test is enabled. Self-test follows different gas law from sensitivity temperature dependence. It changes much smaller than sensitivity; this is why the temperature compensation is not done on self-test conditions.

Note2: Initial offset monitoring is a much better and reliable method to ensure sensor integrity, since it is ultra sensitive to sensor structure defect and damage. As long as initial offset is within specification the sensor is functioning correctly.

The sensor structure for the Thermal technology is guaranteed to fall outside the specified initial zero g offset parameters if the sensor is damaged or thermopile is failing. In most cases this will result in either signal path saturation or in the Hardware Error (HE) status bit being set.

PCB LAYOUT AND FABRICATION SUGGESTIONS

Reference figure and the notes below for recommendations on connecting a power source to the MEMSIC device and PCB fabrication.

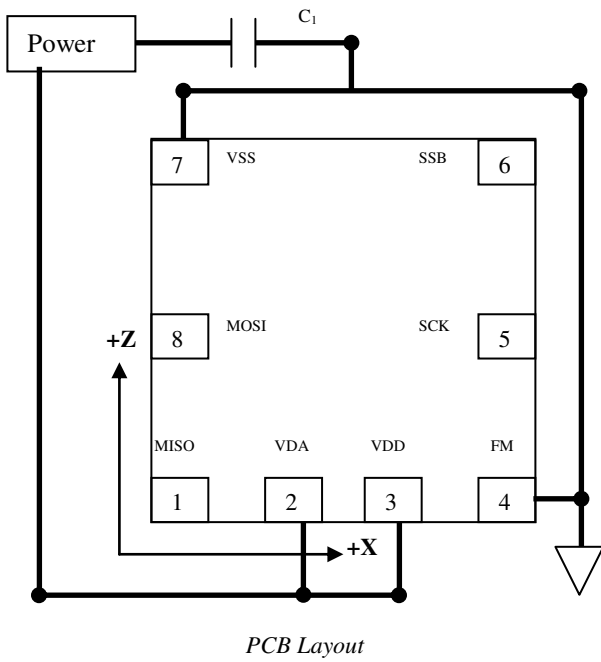

in the thermal sensor through the VDD and VSS pins. The nominal heater resistance is about 500ohm, and nominal heater power is about 7.5 mW. With VDD=5.0V, peak current in the heater element is approximately 10 mA. An internal switching regulator ensures that heater power remains essentially constant with temperature and supply voltage variations. This regulator uses Pulse Width Modulation (PWM) and operates at a fundamental frequency of 1.6 MHz. At VDD=5V, the PWM regulator duty cycle is nominally 15-20%. The bypass capacitor should be able to deliver the required charge during each regulator switching period to ensure low supply noise.

3. Robust low inductance ground and supply wiring should be used.
4. Care should be taken (like isolated rings and planes, signal route out perpendicular to the external thermal gradient) to ensure there is “thermal symmetry” on the PCB immediately surrounding the MEMSIC device and that there is no significant heat source nearby. This will minimize any errors in the measurement of acceleration.

Notes:

1. $C_1 = 1.0\mu\text{F}$
2. The bypass capacitance should be placed near the VDD and VSS pins to ensure low noise performance and accurate outputs. The predominant transient currents on the MXP7205VW are supplied to the heater element

SERIAL PERIPHERAL INTERFACE PROTOCOL

The Serial Peripheral Interface (SPI) is a synchronous serial communication subsystem. The SPI described here is a 16-bit variation of the original 8-bit design. There are four pins associated with the SPI: 1. SCK (serial clock), 2. MISO (master in/ slave out), 3. MOSI (master out/ slave in), and 4. SSB (slave select bar). Internal to each device on the SPI bus is a 16-bit shift register. Devices can operate in either a master or slave role. There can only be one master on the SPI bus at any given time. The pins MISO, MOSI, and SCK are tied together for all devices on the bus. To initiate a data transfer, the master device pulls SSB low on the slave device that it wishes to communicate with. Internal to the slave device this accomplishes two things: 1. It allows SCK (generated by the master) to pass through to the shift register, and 2. It enables output MISO (all unselected slave devices on the bus will have MISO tri-stated). During an SPI transfer, a 16-bit word is shifted out of MISO, while a different 16-bit word is simultaneously shifted into MOSI, synchronous with clock SCK (for the master device, the roles of MISO and MOSI are reversed). Another way to view the transfer is that a 16-bit shift register in the master, and another 16-bit shift register in the slave are connected as a circular 32-bit shift register. When a transfer occurs, this distributed shift register is shifted 16 bit positions; thus the data words in the master and slave are effectively exchanged.

The SPI on the MXP7205VW is designed to operate only in the slave mode. It uses the protocol CPHA = 0, CPOL = 0, that is, data changes on MOSI and MISO on the falling edge of SCK, and is clocked into the shift register on the rising edge of SCK.

When the MXP7205VW is selected as the slave device, 16-bits of data, MSB first, are simultaneously shifted from the master to the slave, and from the slave to the master on the 16 rising edges of SCK. After the 16th rising edge of SCK, the slave shift register will contain the 16-bit word that was transferred from the master. Internal to the MXP7205VW there is a 16-bit bus that serves both as the address bus and the data bus. Immediately after the 16th rising edge of SCK, the internal bus will be driven by the shift register outputs, and will be used as the address bus. When SCK falls, the address on the internal bus will be latched into the address decoders. During the time between the last falling edge of SCK and the next falling edge of SSB, data will be placed on the internal bus in accordance with the instruction received by the address decoders. On the rising edge of SSB, the data on the internal bus will be latched into the appropriate register. The rising edge of SSB also signals the end of the data transfer.

There are 2 types of data transfers supported by the MXP7205VW SPI: 1. Master reading the x and y/z channel MSB and LSB accelerometer output registers, and 2. Master reading and writing the MXP7205VW 8-bit control register. If bit 13, "SEN", of the word written from the master to the MXP7205VW is hi, then the instruction is a read of an accelerometer output register. If bit 13 is low, then the instruction is either a read or write of the MXP7205VW control register.

The protocol for reading the accelerometer output registers is shown in following tables

Sensor Data Request (MOSI):

MSB															LSB
15	14	13	12	11	10	9	8	7	6	5	4	3	2	1	0
SQ1	SQ0	SEN	SQ2	-	-	-	-	-	-	-	-	LC3	LC2	LC1	LC0

-	-	1	-	Accelerometer output LSB register, x-channel								-	-	0	0
-	-	1	-	Accelerometer output LSB register, y/z-channel								-	-	0	1
-	-	1	-	Accelerometer output MSB register, x-channel								-	-	1	0
-	-	1	-	Accelerometer output MSB register, y/z-channel								-	-	1	1

Sensor Data Request

Name	Bit Position	Definition
SQ2:SQ0	15,14,12	Sequence identifier - used for synchronizing samples
SEN	13	SEN = 1, sensor data read; SEN = 0, control register read or write.
LC3:LC0	3:0	Logical channel select
	11:4	Not used for sensor data request.

Sensor Data Request MOSI Bit Definition

Sensor Data Response (MISO):

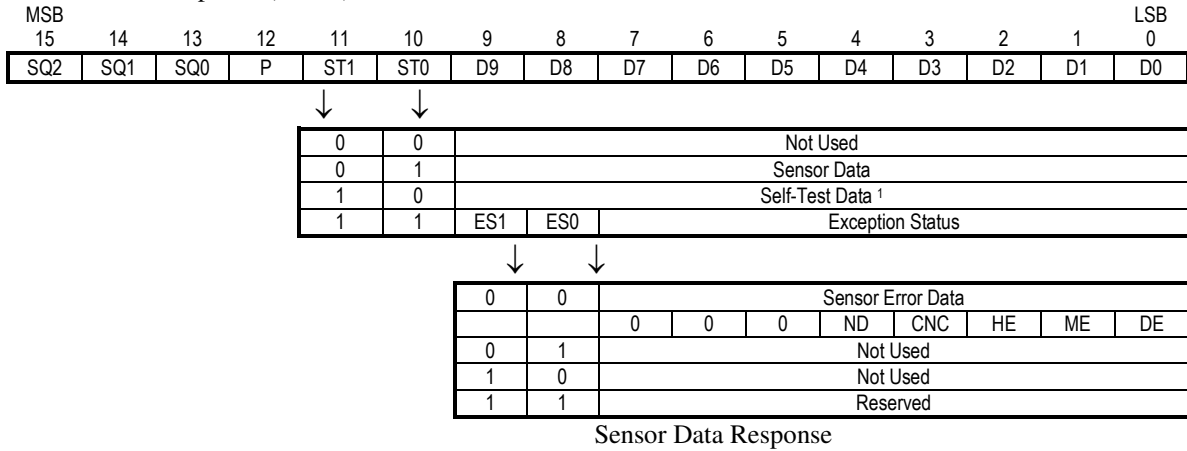

Notes: ¹ The self-test data response, with ST1 = 1, ST0 = 0, will occur when the control register contains the values ST = 1 (self-test enabled), or TC = 1 (temperature compensation disabled).

Sensor Data Response MISO Bit Definition

Name	Bit Position	Definition
SQ2:SQ0	15:13	Sequence identifier - used for synchronizing sensor samples
P	12	Parity - Ensures odd parity for bits 15:0 of MISO
ST1:ST0	11:10	Status - Identifies contents in D9:D0 of MISO (sensor data, self-test data, exception)
ES1:ES0	9:8	Exception Status - Identifies contents of exception data (sensor error status)
	7:5	Not used if ST1:ST0 = 11
ND	4	No Data - Not used.
CNC	3	Conditions Not Correct - Set if attempt is made to read accelerometer data when chip is in power down.
HE	2	Hardware Error - Set if heater control loop is out of regulation.
ME	1	Reserved
DE	0	Reserved
D9:D0	9:0	Sensor Data - For ST1:ST0 = 01 or 10. Data is LSB justified, and MSB bits are padded with '0' if data length is less than 10.

Sensor Data Response MISO Bit Definition

The error codes supported by the MXP7205VW when an attempt is made to read accelerometer data (SEN = 1), are CNC = 1, if the chip is in the power down state, and HE = 1, if the heater control loop is out of regulation.

If self-test is activated when an attempt is made to read accelerometer data, this will be indicated by returning ST1:ST0 = 10.

When reading accelerometer data, there are 4 modes of operation, defined by the settings of bits DAT1 and DAT0 in the MXP7205VW Control Register. The modes of operation for the different settings are given in following table.

DAT1	DAT0	Definition
0	0	If the MSB or LSB register of either the x or y/z channel is read, then both the x and y/z channel outputs are frozen until the MSB and LSB of both the x and y/z channels are read.
0	1	If the MSB or LSB register of either the x or y/z channel is read, then that channel's output is frozen until the other byte (either LSB or MSB) is read.
1	0	If the MSB register of either the x or y/z channel is read, then both the x and y/z channel outputs are frozen until the MSB of the other channel is read.
1	1	Channel outputs are continuously updated.

Channel Output Modes of Operation

The output of either the x or y/z channel is a 14-bit word. Since only 10-bits of data are available from a channel output read, two read cycles are required to obtain the full 14-bit data word. The 14-bit word can be considered to be stored in a Most Significant

Byte (MSB) Register, which contains the 10 most significant bits, and a Least Significant Byte (LSB) Register, which contains the 4 least significant bits, right justified, with zeros inserted for the remaining 6 data bits. If a 14-bit output is desired, then the MSB and LSB register reads should be from the same output sample. Therefore, in the 14-bit output mode of operation (DAT1 = 0), the filter output will not be updated until both the MSB and LSB for that channel have been read. It may also be desirable to have a reading of both the x and y/z channel outputs corresponding to the same output sample. In that case, setting DAT0 = 0 will cause the filter outputs to be frozen, after a read of one of the channels, until both channels are read.

A 10-bit mode of operation is also available. In this case, only the MSB register of the x and y/z channels are read. Setting DAT0 = 0 requires that both channels be read before the filter outputs are updated. When DAT1 = 1 and DAT0 = 1, the filter outputs are updated continuously.

Data transfer format:

14bits operation mode			10bits operation mode		
LSB	Hex	g	LSB	Hex	g
6144	1800	7.68	384	180	7.68
4000	0FA0	5	250	0FA	5
800	320	1	50	32	1
1	1	0.00125	1	1	0.02
0	0	0	0	0	0
-1	3FFF	-0.00125	-1	3FF	-0.02
-800	3CE0	-1	-50	3CE	-1
-4000	3060	-5	-250	306	-5
-6144	2800	-7.68	-384	280	-7.68

The protocol for reading and writing to the control register is shown in following tables.

Slave Data Request (MOSI):

MSB	15	14	13	12	11	10	9	8	7	6	5	4	3	2	1	LSB	0
	OP1	OP0	SEN	A4	A3	A2	A1	A0	D7	D6	D5	D4	D3	D2	D1	D0	
	↓	↓															
	0	0	0	Not Used													
	0	1	0	Write Address				Write Data									
	1	0	0	Read Address				Don't Care									
	1	1	0	Not Used													

Slave Data Request

Name	Bit Position	Definition
OP1:OP0	15:14	Opcode - Defines operation (Read, Write).
SEN	13	SEN = 1, sensor data read; SEN = 0, control register read or write.
A4:A0	12:8	Address - For read or write operation.
D7:D0	7:0	Data - For write operation.

Slave Data Request MOSI Bit Definition

Slave Data Response (MISO):

MSB	15	14	13	12	11	10	9	8	7	6	5	4	3	2	1	LSB	0
	-	OP1	OP0	P	ST1	ST0	ES1	ES0	D7	D6	D5	D4	D3	D2	D1	D0	
	↓	↓															
	0	0	P	1	1	1	0	Error Data									
								0	0	0	0	0	SE	RE	DU		
	0	1	P	1	1	1	0	Slave Status - Responds with data just written									
	1	0	P	1	1	1	0	Read Data									
	1	1	P	1	1	1	0	-									

Slave Data Response

Name	Bit Position	Definition
OP1:OP0	14:13	Opcode - Identifies contents of Read or Write data in D9:D0 - copied from MOSI if request granted
P	12	Parity - Ensures odd parity for bits 15:0 of MISO
ST1:ST0	11:10	Status - Always '11' for non-sensor response
ES1:ES0	9:8	Exception Status - Always '10' for non-sensor response
D7:D0	7:0	Read Data/Error Data/Status
SE	2	SPI Error - Set if there is an incorrect number of SCK clock pulses during a data transfer frame
RE	1	Request Error - Set to '1' for illegal, or unknown requests
DU	0	Data Unavailable - Not used

Slave Response MISO Bit Definition

Summary of MXP7205VW SPI protocol:

If bit 13 (SEN) of the request is a '1', then the data transfer is a read of one of the accelerometer output registers. Bits 15 (SQ1), 14 (SQ0), and 12 (SQ2) are the sequence bits. This field provides the system with a means of synchronizing the data samples received from the sensors. Bits 3:0 are the logical channel bits, LC3:LC0. These bits determine whether the x or y axis data is being read, and whether the MSB or LSB byte is being read. None of the other bits in the request have any meaning.

If bit 13 (SEN) of the request is a '0', then the data transfer is a write or read of the MXP7205VW control register. Bits 15 (OP1), and 14 (OP0) define whether the request is a write (OP1:OP0 = 01), or a read (OP1:OP0 = 10). Since the MXP7205VW has only one control register, the address bits in the request are irrelevant. All requests with SEN=0, are assumed to be directed to the 8-bit control register. The only other bits that have meaning, besides 15:13, for a slave data request, are the data bits 7:0, for the case of a write to the control register.

The errors that are detected for a sensor data request are: 1. CNC = 1, chip is in power down state; and 2. HE = 1, heater control loop is out of regulation.

If the number of SCK rising edges during a data transfer (period of time from the falling edge of SSB to the rising edge of SSB) is different from 16, then bit 2 (SE) will be set. If the request does not correspond to any of the requests defined in this specification, then bit 1 (RE) will be set. The remaining bits in the response, for these errors, will correspond to those given in the table of Slave Data Response.

The response on MISO during the first command following a reset will be a slave data error response with RE = 1, DU = 1.

MXP7205VW CONTROL REGISTER

The MXP7205VW contains a single 8-bit control register. This register can be written to and read by the master device. The bit definitions are shown in following table, followed by a description of each control bit.

MSB						LSB	
7	6	5	4	3	2	1	0
DAT1	DAT0	RFILT	FTST1	FTST0	TC	ST	PD

MXP7205VW Control Register

DAT1:DAT0 - These 2 bits determine how the accelerometer output registers will be updated.

RFILT - Writing this bit to a '1' resets the digital filters for the x and y/z channels. The bit must be cleared for normal operation to resume. Can be used in the testing of the filters. While the digital filters are in reset (RFILT=1), the x and y acceleration outputs will be 0.

FTST1:FTST0 - These bits are used to facilitate testing of the digital filter. The different modes of operation are described in following table. Both the x channel and y/z channel filters are affected in the same way.

FTST1	FTST0	Definition
0	0	Normal operating mode
0	1	Filter input comes from pattern generator with 25% pulse density. Expected Xout/Yout (Zout) values are -3072, settling time: maximum 60mS.
1	0	Filter input comes from pattern generator with 50% pulse density. Expected Xout/Yout (Zout) values are $0 \pm 1\text{LSB}$, settling time: maximum 60mS.
1	1	Filter input comes from pattern generator with 75% pulse density. Expected Xout/Yout (Zout) values are +3072, settling time: maximum 60mS.

Digital Filter Test Modes

TC - Setting this bit disables the temperature compensation of sensitivity.

ST - Setting this bit enables self-test.

PD - Setting this bit puts the device into a zero-current, non-functional, power down state.

Note: All bits in the control register are initialized to 0 when power is applied to the device

MECHANICAL PACKAGE OUTLINE DIMENSIONS

