

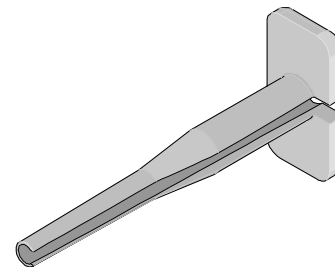

# Terminal Extractor Tool Instruction Sheet Order No. 63813-1900



## FEATURES

- This Extractor Tool is for the removal of pin and socket terminals from sealed plug and receptacle assemblies.

## SCOPE

Products: Contact Pins and Hooded Sockets, 16-18 AWG.

Terminal Series No.	Terminal Order No.			
84590	84590-0020	84590-0025	84590-0026	84590-0031

## OPERATION:

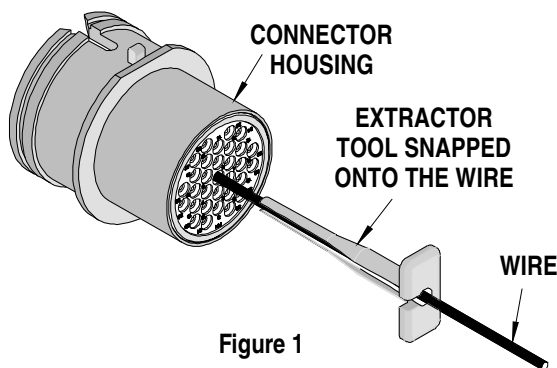

Figure 1

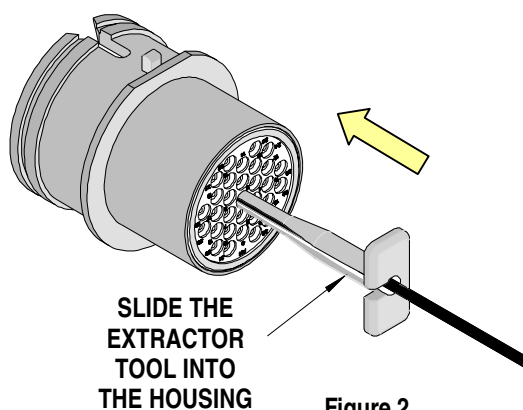

Figure 2

1. Snap the Extractor Tool over the wire of the contact to be removed. See Figure 1.
2. Slide the tool along the wire and into the connector housing. As the tool enters the housing, do not twist the tool or insert it at an angle.
3. Continue to push the tool into the housing until it engages the contact and resistance is felt. See Figure 2.
4. While holding the wire against the Extractor Tool, gently pull the wire, tool, and contact out of the connector. If the contact cannot be pulled back, the Extractor Tool needs to be pushed farther into the connector to fully release the latches. See Figure 3.

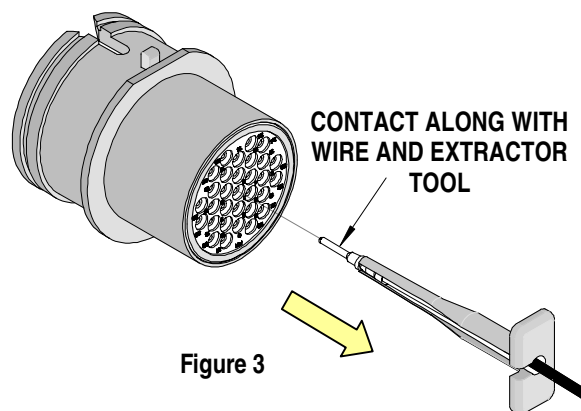

Figure 3

**Americas Headquarters**  
Lisle, Illinois 60532 U.S.A.  
1-800-78MOLEX  
amerinfo@molex.com

**Far East North Headquarters**  
Yamato, Kanagawa, Japan  
81-462-65-2324  
feninfo@molex.com

**Far East South Headquarters**  
Jurong, Singapore  
65-6-268-6868  
fesinfo@molex.com

**European Headquarters**  
Munich, Germany  
49-89-413092-0  
eurinfo@molex.com

**Corporate Headquarters**  
2222 Wellington Ct.  
Lisle, IL 60532 U.S.A.  
630-969-4550  
Fax: 630-969-1352

Visit our Web site at <http://www.molex.com>