

20 Watts

APA06

APA04 - Boost

Total Power: 20 Watts
Input Voltages: 3.3V, 5V
No. of Outputs: Single



Electrical Specs

Input

Input range	3.0 to 5.5V (Buck) 3.0 to 4.0V (Boost)
Efficiency	90% (5/3.3) , 83% (1.8V)

Output

Voltage tolerance	± 1.0%
Line regulation	± 0.5%
Load regulation	± 0.5%
Noise/ripple	50mV P-P
Short circuit protection	Auto-recovery
Transient response	4%Vo, 200us

Temperature Regulation ±0.02 %Vo/°C

Switching frequency 430kHz typ

Temperature coefficient ± 0.03%Vo/°C

Isolation

Non Isolated

Special Features

- Excellent for POL Applications
- High Efficiency - Non Isolated
- 3.3V and 5V input,
- Standard SIP package 2.5 X .55 X .31"
- Enable and Trim Function
- Overcurrent Protection
- Sense Pins

Environmental

Operating ambient temperature: -

25°C to 55°C (full load, 200LFM)

Storage temperature: -40°C to +125°C

MTBF: =7,000,000 hours (Bellcore TR332,
Ta=25°C)

Weight: = 7.5 grams max

Safety

UL UL 1950 Recognized
CSA CAN22.2-950 Recognized

TUV EN60950 Certified

AMERICAS

5810 Van Allen Way
 Carlsbad, CA 92008
 Telephone: 760-930-4600
 Facsimile: 760-930-0698

EUROPE

Astec House, Waterfront Business Park
 Merry Hill, Dudley
 West Midlands, DY5 1LX, UK
 Telephone: 44 (1384) 842-211
 Facsimile: 44 (1384) 843-355

ASIA

Units 2111-2116, Level 21
 Tower 1, Metroplaza
 223, Hing Fong Road
 Fwai Fong, New Territories
 Hong Kong
 Telephone: 852-2437-9662
 Facsimile: 852-2402-4426



APA06/04

Ordering Information

Input Voltage	Output Voltage	Efficiency	Model Number
Buck			
3.0-5.5 V	1.2V @ 6.0 A	80%	APA06K04
3.0-5.5 V	1.5V @ 6.0 A	81%	APA06M04
3.0-5.5 V	1.8V @ 6.0 A	83%	APA06Y04
3.0-5.5 V	2.1V @ 6.0 A	86%	APA06D04
4.5-5.5 V	2.5V @ 6.0 A	87%	APA06G05
4.5-5.5 V	3.3V @ 6.0 A	90%	APA06F05
Boost			
3.3-4.0 V	5.0V @ 4.0 A	89%	APA04A03

Notes:

1. Add -E to eliminate Sense and Power Good feature
2. Right Angle Pins Available

APA04 (Boost) Pinout

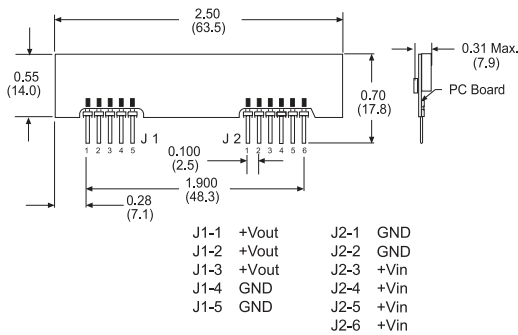

APA06 (Buck) Pinout

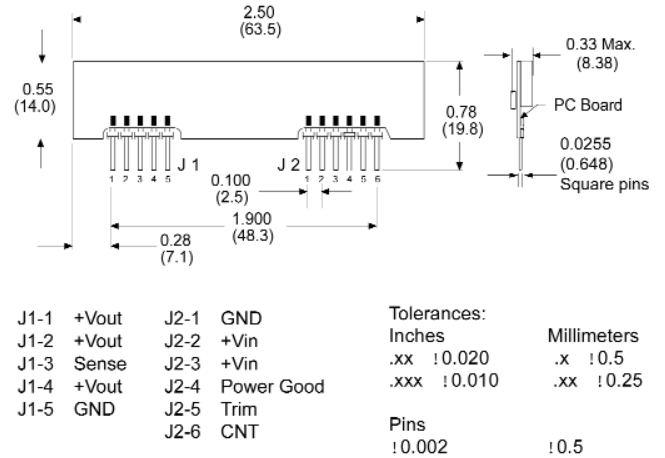

Notes:

1. Recommended Input Filter - 220uF Electrolytic Cap in parallel with 2.2uF Ceramic Cap Vin+ to GND
2. Recommended Output Filter - 2.2uF Ceramic Cap in parallel with 1000uF Electrolytic Cap (Vout+ to GND)
3. 20 MHz bandwidth. An external 0.1 uf ceramic capacitor is recommended to be placed from +V out to comm.
4. All specifications are typical at nominal line, full load, and 25°C unless otherwise noted.
5. All specifications subject to change without notice.
6. Mechanical drawings are for reference only.