

Resistive Type Touch Screen Controller ICs

BU21024FV-M

General Description

Unlike most resistive touch screen controllers, the BU21024 4-wire resistive touch screen controller enables dual-touch detection and gesture recognition. These intelligent controllers expose a set of registers to a HOST processor and are configured through software. The controllers can detect single point coordinates, dual coordinates, pinch, spread, rotate left and rotate right gestures, enabling pan and zoom operations in applications that previously had to rely exclusively on capacitive touch technology. Resistive touch does not require custom screen development which reduces development cost, and results in faster time to market across a family of products.

Features

- Enables single touch, dual touch & gesture recognition using standard 4-wire resistive touch screens
- Adjustable touch detection threshold allows fine tuning of pressure sensitivity for an application
- Enables measurement of single point touch pressure
- SPI- and I²C interface for interfacing to HOST processor
- Programmable interrupt polarity
- 10-bit ADC provides sufficient resolution for finger or stylus inputs
- Firmware for internal CPU may be downloaded from HOST processor or from an EEPROM
- Includes filtering options to eliminate false coordinates
- Built in support for intelligent calibration
- Easy to swap X & Y coordinates or adapt to different touch screen connections
- Single 3V power supply
- Available in small packages and temperature ranges
- Ideally suited for large volume automotive, consumer, and industrial applications
- AEC-Q100 Qualified

Packages

SSOP-B28

W(Typ) x D(Typ) x H(Max)
10.0mm x 7.60mm x 1.35mm



Applications

- Products with an LCD can benefit from pan and zoom operations.
- Smart phones, Digital Cameras, Video Cameras, GPS Receivers, Printers, Copiers, automotive navigation screens, touch kiosks
- Tablet PCs , Notebook computers, LCD displays (with USB interface)
- Car navigation system, Car Audio

Key Specifications and Lineup

Parameter	BU21024FV-M
Screen	4-wire resistive touch screens
Maximum Detection Point	2
Integrated Filter Process	Yes
Gesture Detection	Yes
Supplied Voltage Range(V)	2.7 to 3.6
Temperature Range(°C)	-40 to +85
Host I/F	4-wire SPI 2-wire serial
Package	SSOP-B28

○Product structure : Silicon monolithic integrated circuit ○This product has no designed protection against radioactive rays

www.rohm.com

© 2014 ROHM Co., Ltd. All rights reserved.
TSZ22111 · 14 · 001

Pin Configuration and Pin Description

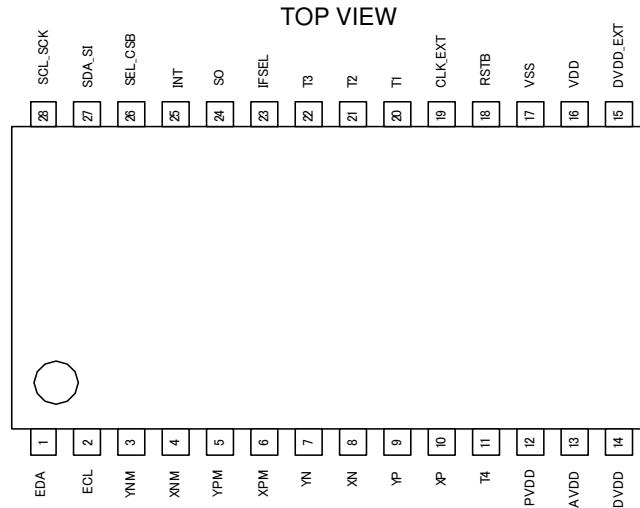

No.	Pin Name	I/O	Function				Figure
1	EDA	I/O	EEPROM SDA				C
2	ECL	O	EEPROM SCL				C
3	YNM	I/O	Screen interface (Test input)				E
4	XNM	I/O	Screen interface (Test input)				E
5	YPM	I/O	Screen interface (Test input)				E
6	XPM	I/O	Screen interface (Test input)				E
7	YN	I/O	Screen interface				E
8	XN	I/O	Screen interface				E
9	YP	I/O	Screen interface				E
10	XP	I/O	Screen interface				E
11	T4	I/O	Test pin				E
12	PVDD	O	Regulator output (for supply screen voltage)				-
13	AVDD	O	Regulator output (for supply analog block)				-
14	DVDD	I/O	Regulator output (for supply digital block) or supply digital voltage				-
15	DVDD_EXT	I	Digital voltage enable (H=Hi-Z , L=DVDD enable)				E
16	VDD	-	Supply voltage				-
17	VSS	-	Ground				-
18	RSTB	I	H/W reset				E
19	CLK_EXT	I	Supply external clock for debug				A
20	T1	I	Test pin				A
21	T2	I	Test pin				A
22	T3	I	Test pin				A
23	IFSEL	I	Interface select pin (L=SPI, H=2-wire serial)				A
24	SO	O	SPI	Serial data output	2-wire	-	F
25	INT	O	Interrupt output				C
26	SEL_CS	I	SPI	Chip select	2-wire	Slave address select	C
27	SDA_SI	I/O	SPI	Serial data input	2-wire	Serial data in-out	C
28	SCL_SCK	I	SPI	Serial clock input	2-wire	Serial clock input	C

1. Please use 1.0μF capacitors between AVDD and DVDD to GND, and leave PVDD terminal open.
2. If DVDD_EXT="H", the DVDD pin can be connected to an external 1.8V power source.
3. Please pull up the ECL, EDA, and INT pins using 10k ohm resistors as shown in the application diagram at the end of this document. ECL and EDA pins may be directly connected to GND if an external EEPROM is not being used. Please connect a 0.1μF capacitor between T4 and GND. T1, T2 & T3 pins should be connected to GND.
4. When using the 2 wire serial interface, please pull up the SCL_SCK, SDA_SI pins via 10k ohms and leave SO unconnected.
5. Please note that the values of resistors and capacitors mentioned here are only recommended values.
6. RSTB should be held low until supply voltage VDD has ramped up and has reached a stable level.
7. The polarity of INT pin is programmable via register 0x30
8. Connect CLK_EXT to GND for normal use
9. Please leave the XPM, XNM, YPM, YNM terminals open if they are not being used.
10. INT terminal is used as input pin in test mode.

I/O equivalence circuit

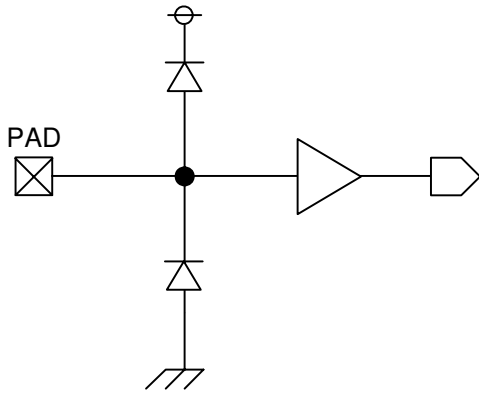

Figure A

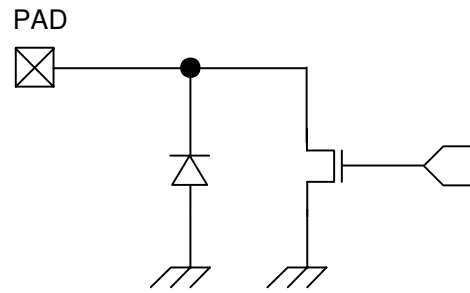

Figure B

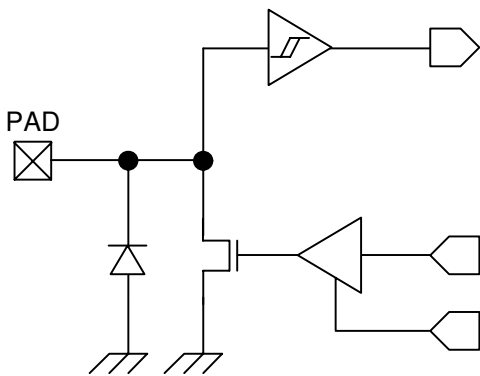

Figure C

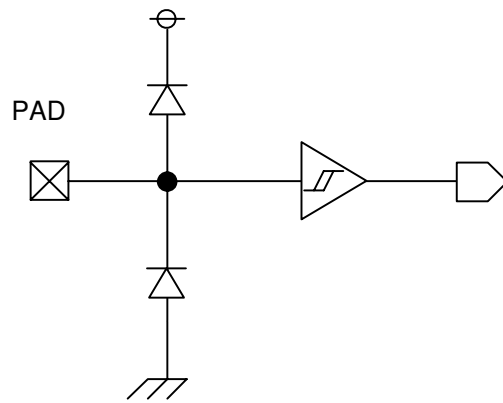

Figure D

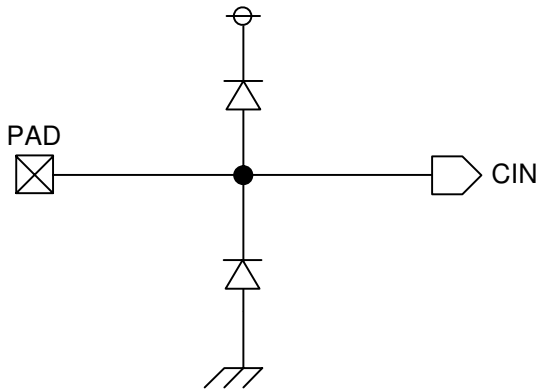

Figure E

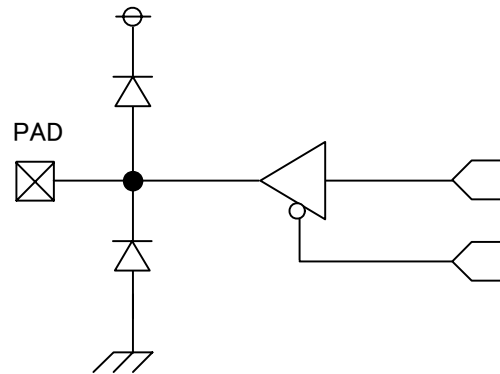
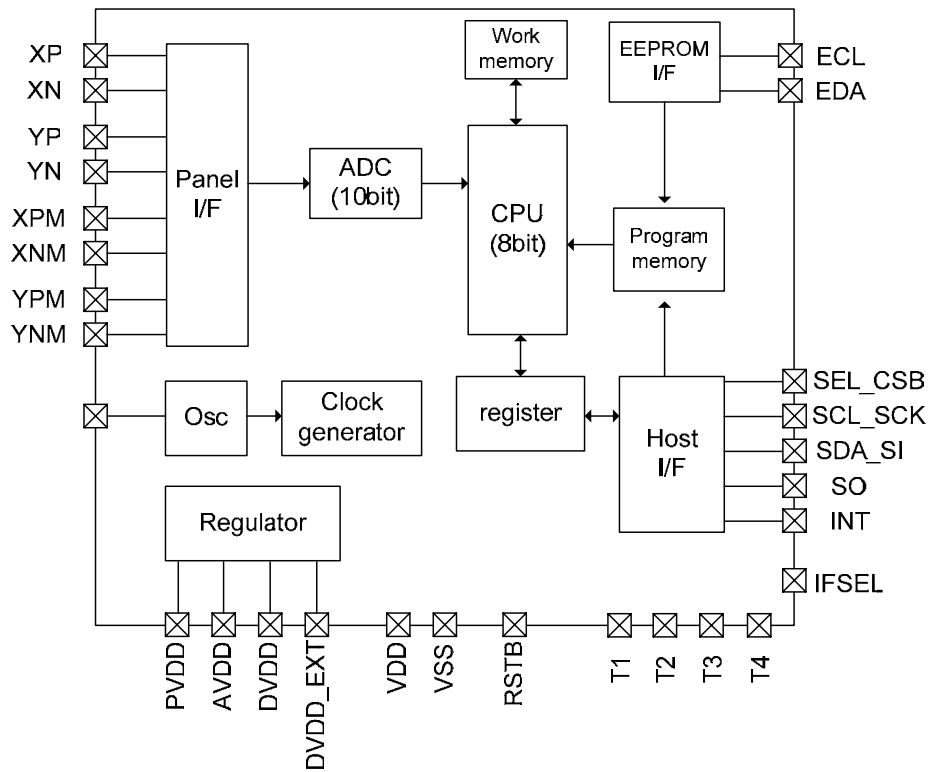

Figure F

Figure I/O Equivalent Circuit

Block Diagram and Description of each Block



Screen I/F	4-wire or 8-wire resistive touch screen interface
ADC	10-bit A/D converter
OSC	Internal 20MHz oscillator block with optional external clock input
Regulator	Internal regulator provides 1.8V DVDD supply. DVDD can also be supplied from an external source if DVDD_EXT pin is tied high.
Clock Generator	System clock and timing generation (10MHz CPU clock)
CPU Core	For dual touch processing, programmability and HOST interface
Work Memory	Data memory for CPU
Program Memory	Program memory for CPU. Code can be downloaded by HOST processor or from an external EEPROM
EEPROM I/F	To connect to external EEPROM when downloading program memory from EEPROM. Use of external EEPROM is optional.
Host I/F	4-wire SPI or 2-wire I ² C interface provides access to registers

Absolute Maximum Ratings

Parameter	Symbol	Rating	Unit	Conditions
Power Supply Voltage	V _{DD}	-0.3 to +4.5	V	
Input Voltage	V _{IN}	-0.3 to V _{DD} +0.3	V	
Power Dissipation	P _d	0.85 (Note 1)	W	
Storage Temperature Range	T _{stg}	-50 to +125	°C	

(Note 1) Derate by 8.50mW /°C centigrade when ambient temperature exceeds 25°C. Measured using PCB(1 layer) measuring 70x70x1.6mm³.

Caution: Operating the IC over the absolute maximum ratings may damage the IC. The damage can either be a short circuit between pins or an open circuit between pins and the internal circuitry. Therefore, it is important to consider circuit protection measures, such as adding a fuse, in case the IC is operated over the absolute maximum ratings.

Recommended Operating Conditions

Parameter	Symbol	Rating			Unit	Conditions
		Min	Typ	Max		
Power Supply Voltage	V _{DD}	2.70	3.00	3.60	V	
Digital Core Power Supply	DV _{DD}	1.62	1.80	1.98	V	DVDD_EXT=H
Operating Temperature Range	T _{opr}	-40	+25	+85	°C	

Note: The BU21024 controllers can be operated with a single 3V V_{DD} supply.

It is also possible to supply 1.8V DV_{DD} from an external source if the DVDD_EXT pin is connected to logic high.

Electrical Characteristics (T_a=25°C, V_{DD}=3.00V)

Parameter	Symbol	Limit			Unit	Conditions
		Min	Typ	Max		
Low-Level Input Voltage	V _{IL}	-0.5	-	0.2xV _{DD}	V	
High-Level Input Voltage	V _{IH}	0.8xV _{DD}	-	V _{DD} +0.5	V	
Low-Level Output Voltage	V _{OL}	-	-	0.4	V	
High-Level Output Voltage	V _{OH}	V _{DD} -0.4	-	-	V	
Standby Current	I _{ST}	-	-	1	μA	RSTB=L
Sleep Current1	I _{CC1}	-	60	100	μA	DVDD_EXT=L
Sleep Current2	I _{CC2}	-	10	20	μA	DVDD_EXT=H
Operating Current	I _{DD}	-	4	6	mA	No Load
Oscillation Frequency	Freq	18	20	22	MHz	
Resolution	Ad	1024x1024			Bit	
Differential Non-Linearity Error	DNL	-3.0	-	+3.0	LSB	
Integral Non-Linearity Error	INL	-3.0	-	+3.0	LSB	

HOST-I/F mode (4-wire SPI)

(SCK=SCL_SCK, SI=SDA_SI, CSB=SEL_CSB, SO=SO)

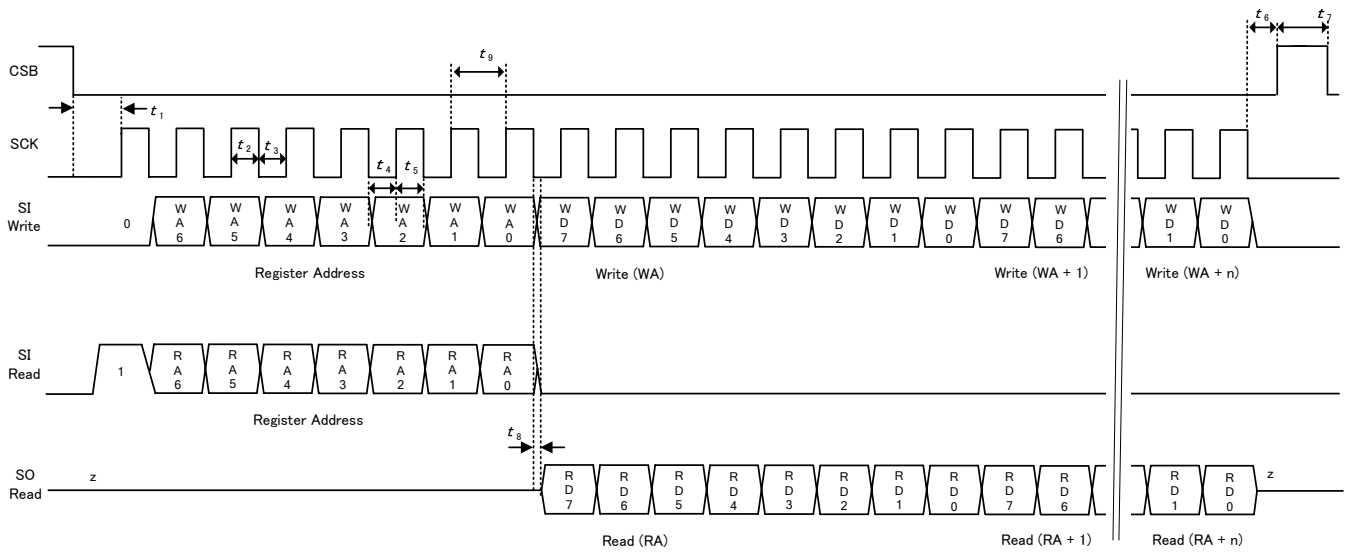

Condition : V_{DD} = 3.0V Ta=25°C

Parameter	Symbol	Limit			Unit	Conditions
		Min	Typ	Max		
CSB Setup Time	t ₁	30	-	-	ns	
SCK "H" Level Period	t ₂	30	-	-	ns	
SCK "L" Level Period	t ₃	30	-	-	ns	
SI Setup Time	t ₄	20	-	-	ns	
SI Holding Time	t ₅	20	-	-	ns	
CSB Holding Time	t ₆	20	-	-	ns	
CSB "H" Level Time	t ₇	50	-	-	ns	
Data Output Delay Time	t ₈	-	-	15	ns	
SCK Frequency	t ₉	-	-	15	MHz	

Note: SPI interface is selected by tying IFSEL pin to logic low. IFSEL= logic high selects the 2-wire Interface

HOST-I/F mode (2-wire serial)

(SCL=SCL_SCK, SDA=SDA_SI)

The 2-wire serial mode presents an I²C interface for all practical purposes, but it is not a complete implementation conforming to the I²C specification. BU21024FV-M devices can co-exist with other I²C devices on the same bus. The slave address for 2-wire serial communication is 5Ch or 5Dh. This is determined by the SEL_CS_B pin.

SEL_CS_B = "L" : Slave address = 5Ch
 SEL_CS_B = "H" : Slave address = 5Dh

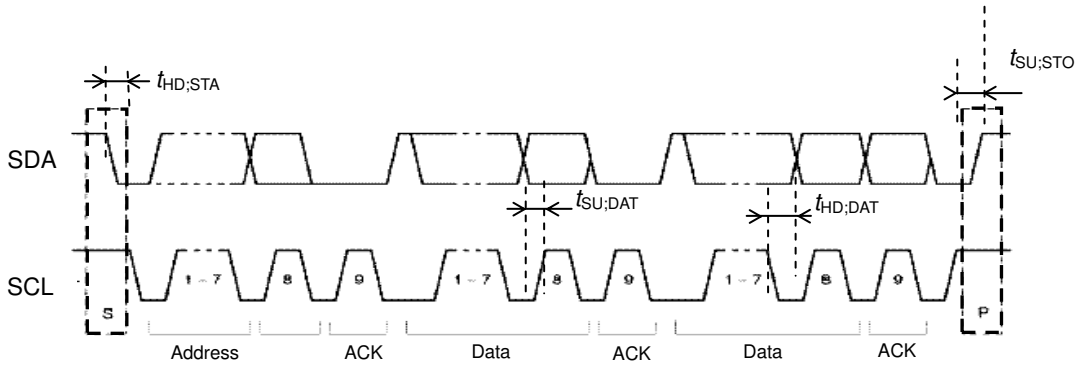

Parameter	Symbol	Limit			Unit	Conditions
		Min	Typ	Max		
SCL Clock Frequency	f _{SCL}	0	-	400	kHz	
START Condition Hold Time	t _{HD:STA}	0.6	-	-	μs	
SCL "L"	t _{LOW}	1.3	-	-	μs	
SCL "H"	t _{HIGH}	0.6	-	-	μs	
Data Hold Time	t _{HD:DAT}	0.1	-	-	μs	
Data Setup Time	t _{SU:DAT}	0.1	-	-	μs	
STOP Condition Setup Time	t _{SU:STO}	0.6	-	-	μs	

•Write protocol

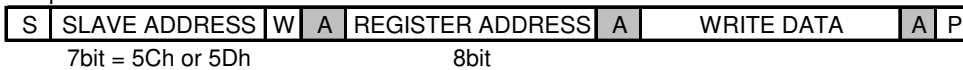

•Read protocol

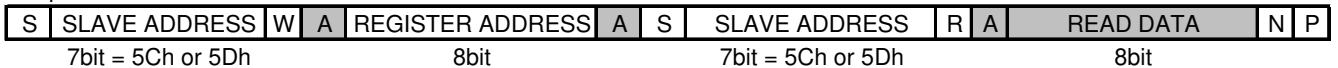

- S = START condition
- P = STOP condition
- R = data direction READ (SDA HIGH)
- W = data direction WRITE (SDA LOW)
- A = acknowledge (SDA LOW)
- N = not acknowledge (SDA HIGH)

EEPROM I/F

(SCL=ECL , SDA=EDA)

BU21024 controllers include an EEPROM interface for firmware download.
Device address of EEPROM is set via register 0x51(EEPROM_ADDR).

Timing Chart

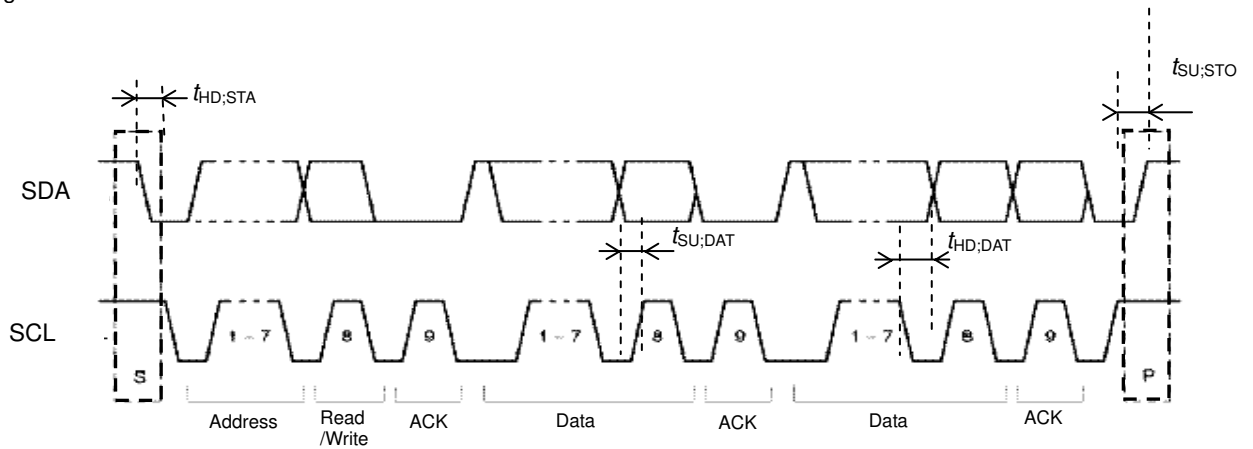

Parameter	Symbol	Limit			Unit	Condition
		Min	Typ	Max		
SCL Clock Frequency	f _{SCL}	270	310	350	kHz	
START Hold Time	t _{HD:STA}	0.7	-	0.9	μs	
SCL "L" Width	t _{LOW}	1.4	-	1.8	μs	
SCL "H" Width	t _{HIGH}	1.4	-	1.8	μs	
Data Hold Time	t _{HD:DAT}	0.7	-	0.9	μs	
Data Setup Time	t _{SU:DAT}	0.7	-	0.9	μs	
STOP Setup Time	t _{SU:STO}	0.7	-	0.9	μs	

Protocol

- *IC does not support the write command.
- *IC supports the following read command.

Start

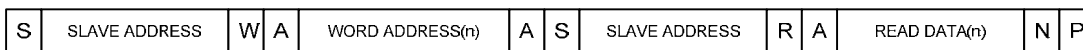

Stop

Background Information

A resistive touch screen is made up of multiple layers of sandwiched resistive films and protective coatings all sitting on top of an LCD display. Resistive touch screens work by direct contact of a stylus or a finger flexing a pair of resistive films, hence any blunt pointing instrument or a gloved finger may be used.

Touch screen resolution

The resolution of a touch screen is typically measured in dots per inch (dpi) and is a function of the physical size of the touch screen and the ADC used in the conversion circuitry. For example, a 3"x5" screen used with the BU21024 devices can provide a theoretical resolution of $1024 / 5 = 204$ dpi. In the case of resistive touch screens, the direct contact nature of its operation and finger thickness often impose an upper limit on the effective system resolution that may be achieved, regardless of the resolution of the ADC itself.

Description of Function

The BU21024 devices connect to a standard 4-wire resistive touch screen on one side and to a HOST processor on the other side. The BU21024 includes four additional sense terminals allowing it to be used with either 4-wire or 8-wire resistive touch screens. The BU21024 include the analog and digital circuitry to process and provide dual touch coordinate data and pinch, spread gesture information to the HOST .

The BU21024 devices include an internal CPU and provide a high degree of programmability by exposing a set of registers that can be accessed by a HOST through SPI or I²C serial interfaces. The IFSEL pin determines whether SPI or I²C interface is selected, The BU21024 devices include an INT pin whose polarity can be programmed via registers. When an interrupt occurs, for example, due to touch detection, the HOST processor is required to read an interrupt status register to determine the cause of the interrupt and take appropriate action.

The program memory of the internal CPU may be initialized via the HOST interface or via an external EEPROM. This is selected by a register setting.

The BU21024 devices support two sensing modes; continuous and interval sensing modes, that are register- selectable. In the continuous sensing mode, the embedded CPU reads Z, X & Y coordinates continuously when a touch is detected. The interval sensing mode allows a delay to be inserted between each cycle.

The BU21024 devices enable optimization of touch detection threshold for a given screen. They also include several sophisticated calibration algorithms.

Often, a description of the registers followed by flow charts requires other document to explain the steps in finer detail.

The other document also includes information on touch screen parameters that one should look for when selecting resistive touch screens for multi-touch.

Application Examples

BU21024FV-M supports 2 HOST interfaces (4-wire SPI and 2-wire serial bus). The figures shown below are application circuits when each interface is used.

- *Please connect the terminal of ECL/EDA to GND, when downloading the Firmware form the HOST.
ECL and EDA pins pull up to VDD if an external EEPROM is used. (example : 10kΩ)
- *Please insert TVS diode or zener diode to each sensor line to enhance resistance to ESD.
- *Please pull up the INT terminal to VDD or HOST IO voltage (max 4.5V).
- *In the case of 4-wire SPI use, please pull down the SO terminal to GND.
If not in use, connect it to the GND.

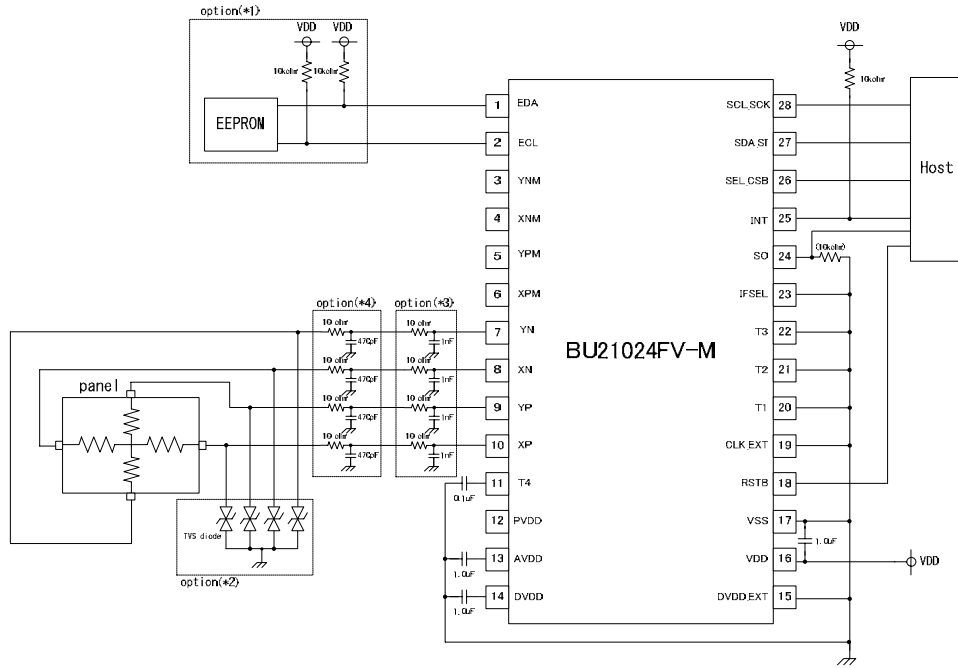

- (*1) EEPROM interface PIN. In using case: 10kΩ pull-up, no-use case: connect to GND.
- (*2) For higher ESD protection.
- (*3) For LCD-noise protection.
- (*4) For RF-noise protection.

Example 3: BU21024FV-M Application Circuit (4-wire SPI)

In the case of 2-wire serial interface use, please pull up the INT, SCL_SCK, SDA_SI terminal to VDD or HOST IO voltage(max4.5V).

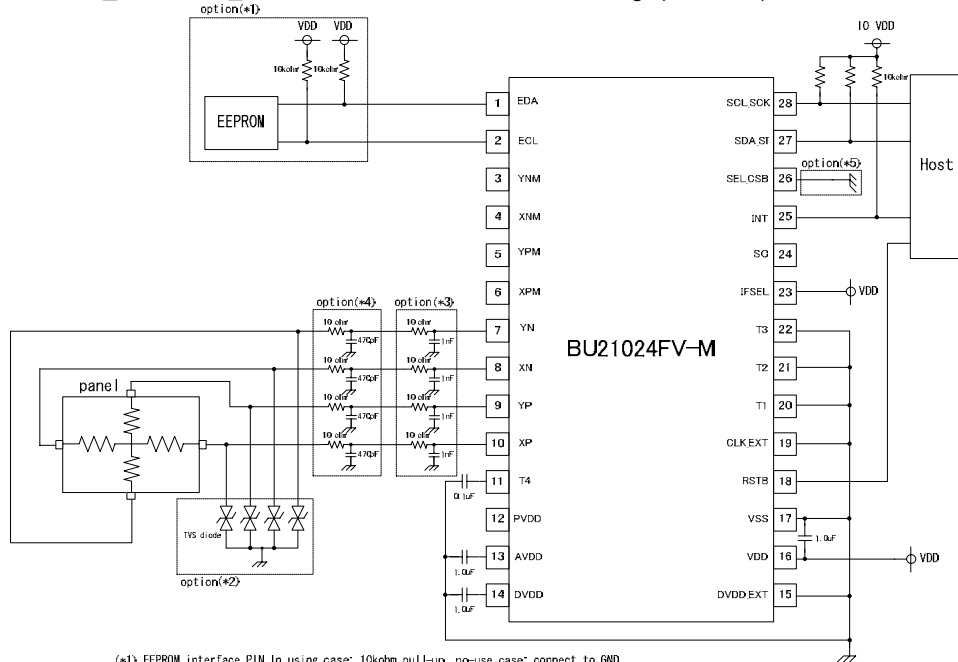

- (*1) EEPROM interface PIN. In using case: 10kΩ pull-up, no-use case: connect to GND.
- (*2) For higher ESD protection.
- (*3) For LCD-noise protection.
- (*4) For RF-noise protection.
- (*5) Please connect to VDD when use as slave address = "BAh(7bit:5DhwWR bit)".

Example 4: BU21024FV-M Application Circuit (2-wire Serial bus)

BU21024FV-M has monitor terminals(XPM, YPM, XNM, YNM) another interface terminals(XP, YP, XN, YN). The monitor terminals are used in touch screen voltage monitor that 4PORT(0x30[2]) set to "0". The monitor terminals open and 4PORT(0x30[2]) set to "1" If they are not being used. The monitor terminals also helps in increasing the screen's dynamic range by reducing error due to PCB wiring resistance.

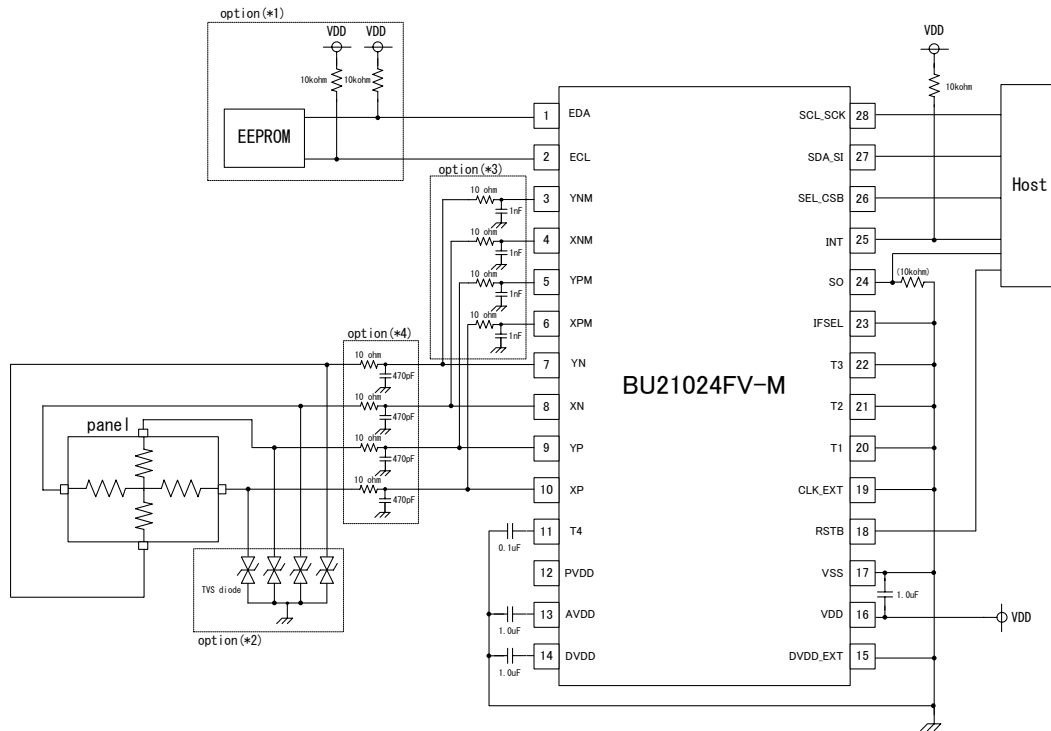

- (*1) EEPROM interface PIN. In using case: 10kohm pull-up. no-use case: connect to GND.
- (*2) For higher ESD protection.
- (*3) For LCD-noise protection.
- (*4) For RF-noise protection.

Example 5: BU21024FV-M Application Circuit (4-wireSPI, using monitor terminals)

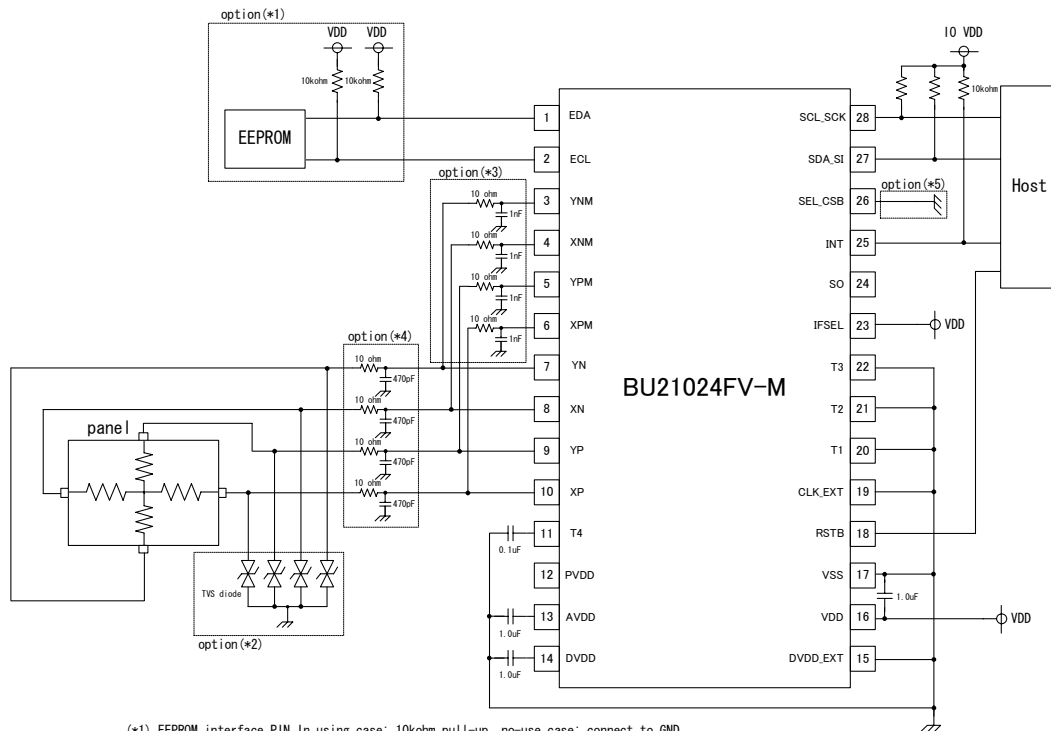

- (*1) EEPROM interface PIN. In using case: 10kohm pull-up. no-use case: connect to GND.
- (*2) For higher ESD protection.
- (*3) For LCD-noise protection.
- (*4) For RF-noise protection.
- (*5) Please connect to VDD when use as slave address = "BAh(7bit:5Dh+WR bit)".

Example 6: BU21024FV-M Application Circuit (2-wire Serial bus, using monitor terminals)

Operational Notes

1. Reverse Connection of Power Supply

Connecting the power supply in reverse polarity can damage the IC. Take precautions against reverse polarity when connecting the power supply, such as mounting an external diode between the power supply and the IC's power supply pins.

2. Power Supply Lines

Design the PCB layout pattern to provide low impedance supply lines. Separate the ground and supply lines of the digital and analog blocks to prevent noise in the ground and supply lines of the digital block from affecting the analog block. Furthermore, connect a capacitor to ground at all power supply pins. Consider the effect of temperature and aging on the capacitance value when using electrolytic capacitors.

3. Ground Voltage

Ensure that no pins are at a voltage below that of the ground pin at any time, even during transient condition.

4. Ground Wiring Pattern

When using both small-signal and large-current ground traces, the two ground traces should be routed separately but connected to a single ground at the reference point of the application board to avoid fluctuations in the small-signal ground caused by large currents. Also ensure that the ground traces of external components do not cause variations on the ground voltage. The ground lines must be as short and thick as possible to reduce line impedance.

5. Thermal Consideration

Should by any chance the power dissipation rating be exceeded the rise in temperature of the chip may result in deterioration of the properties of the chip. The absolute maximum rating of the Pd stated in this specification is when the IC is mounted on a 70mm x 70mm x 1.6mm glass epoxy board. In case of exceeding this absolute maximum rating, increase the board size and copper area to prevent exceeding the Pd rating.

6. Recommended Operating Conditions

These conditions represent a range within which the expected characteristics of the IC can be approximately obtained. The electrical characteristics are guaranteed under the conditions of each parameter.

7. Inrush Current

When power is first supplied to the IC, it is possible that the internal logic may be unstable and inrush current may flow instantaneously due to the internal powering sequence and delays, especially if the IC has more than one power supply. Therefore, give special consideration to power coupling capacitance, power wiring, width of ground wiring, and routing of connections.

8. Operation Under Strong Electromagnetic Field

Operating the IC in the presence of a strong electromagnetic field may cause the IC to malfunction.

9. Testing on Application Boards

When testing the IC on an application board, connecting a capacitor directly to a low-impedance output pin may subject the IC to stress. Always discharge capacitors completely after each process or step. The IC's power supply should always be turned off completely before connecting or removing it from the test setup during the inspection process. To prevent damage from static discharge, ground the IC during assembly and use similar precautions during transport and storage.

10. Inter-pin Short and Mounting Errors

Ensure that the direction and position are correct when mounting the IC on the PCB. Incorrect mounting may result in damaging the IC. Avoid nearby pins being shorted to each other especially to ground, power supply and output pin. Inter-pin shorts could be due to many reasons such as metal particles, water droplets (in very humid environment) and unintentional solder bridge deposited in between pins during assembly to name a few.

Operational Notes - continued**11. Unused Input Pins**

Input pins of an IC are often connected to the gate of a MOS transistor. The gate has extremely high impedance and extremely low capacitance. If left unconnected, the electric field from the outside can easily charge it. The small charge acquired in this way is enough to produce a significant effect on the conduction through the transistor and cause unexpected operation of the IC. So unless otherwise specified, unused input pins should be connected to the power supply or ground line.

12. Regarding the Input Pin of the IC

In the construction of this IC, P-N junctions are inevitably formed creating parasitic diodes or transistors. The operation of these parasitic elements can result in mutual interference among circuits, operational faults, or physical damage. Therefore, conditions which cause these parasitic elements to operate, such as applying a voltage to an input pin lower than the ground voltage should be avoided. Furthermore, do not apply a voltage to the input pins when no power supply voltage is applied to the IC. Even if the power supply voltage is applied, make sure that the input pins have voltages within the values specified in the electrical characteristics of this IC.

13. Ceramic Capacitor

When using a ceramic capacitor, determine the dielectric constant considering the change of capacitance with temperature and the decrease in nominal capacitance due to DC bias and others.

14. Others

In case of use this IC, please peruse some other detail documents, we called Functional description, Application note.

Ordering Information

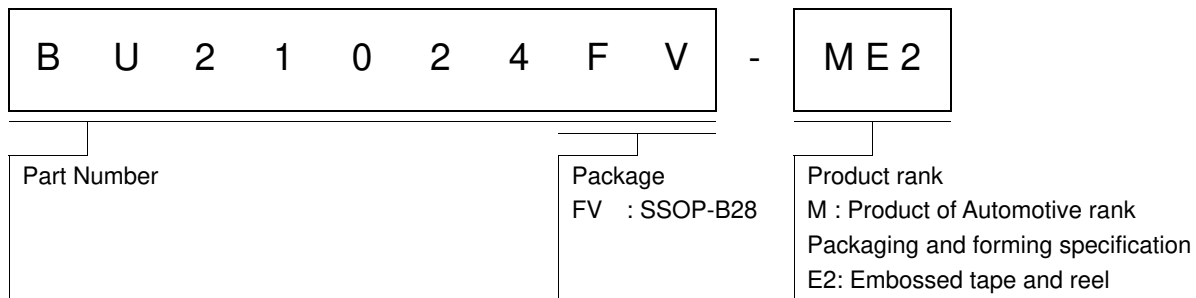

Marking Diagrams

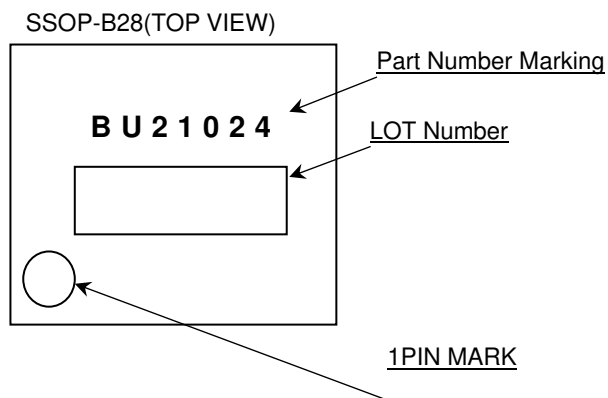

Physical Dimension Tape, and Reel Information

Package Name	SSOP-B28 (BU21024FV-M)
--------------	------------------------

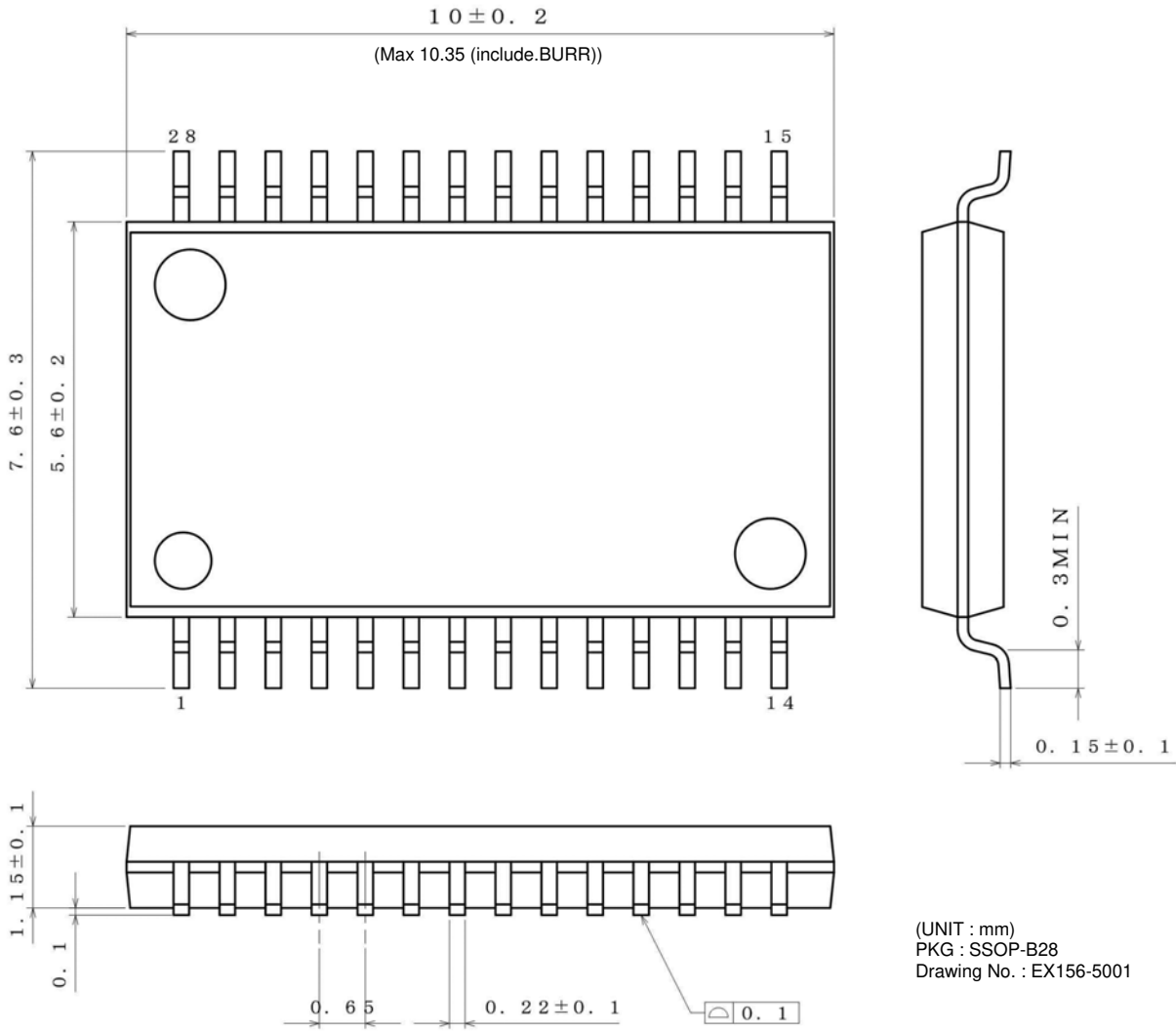

(UNIT : mm)
 PKG : SSOP-B28
 Drawing No. : EX156-5001

<Tape and Reel information>

Tape	Embossed carrier tape
Quantity	2000pcs
Direction of feed	E2 (The direction is the 1pin of product is at the upper left when you hold reel on the left hand and you pull out the tape on the right hand)

Reel

1pin

Direction of feed

*Order quantity needs to be multiple of the minimum quantity.

Revision History

Date	Revision	Changes
07.Oct.2013	001	New Release
07.Feb.2014	002	Remove Bu21023GUL/MUV descriptions
31.Mar.2014	003	Modified application circuit and option descriptions

Notice

Precaution on using ROHM Products

- If you intend to use our Products in devices requiring extremely high reliability (such as medical equipment ^(Note 1), aircraft/spacecraft, nuclear power controllers, etc.) and whose malfunction or failure may cause loss of human life, bodily injury or serious damage to property ("Specific Applications"), please consult with the ROHM sales representative in advance. Unless otherwise agreed in writing by ROHM in advance, ROHM shall not be in any way responsible or liable for any damages, expenses or losses incurred by you or third parties arising from the use of any ROHM's Products for Specific Applications.

(Note1) Medical Equipment Classification of the Specific Applications

JAPAN	USA	EU	CHINA
CLASS III	CLASS III	CLASS II b	CLASS III
CLASS IV		CLASS III	

- ROHM designs and manufactures its Products subject to strict quality control system. However, semiconductor products can fail or malfunction at a certain rate. Please be sure to implement, at your own responsibilities, adequate safety measures including but not limited to fail-safe design against the physical injury, damage to any property, which a failure or malfunction of our Products may cause. The following are examples of safety measures:
 - Installation of protection circuits or other protective devices to improve system safety
 - Installation of redundant circuits to reduce the impact of single or multiple circuit failure
- Our Products are not designed under any special or extraordinary environments or conditions, as exemplified below. Accordingly, ROHM shall not be in any way responsible or liable for any damages, expenses or losses arising from the use of any ROHM's Products under any special or extraordinary environments or conditions. If you intend to use our Products under any special or extraordinary environments or conditions (as exemplified below), your independent verification and confirmation of product performance, reliability, etc, prior to use, must be necessary:
 - Use of our Products in any types of liquid, including water, oils, chemicals, and organic solvents
 - Use of our Products outdoors or in places where the Products are exposed to direct sunlight or dust
 - Use of our Products in places where the Products are exposed to sea wind or corrosive gases, including Cl₂, H₂S, NH₃, SO₂, and NO₂
 - Use of our Products in places where the Products are exposed to static electricity or electromagnetic waves
 - Use of our Products in proximity to heat-producing components, plastic cords, or other flammable items
 - Sealing or coating our Products with resin or other coating materials
 - Use of our Products without cleaning residue of flux (even if you use no-clean type fluxes, cleaning residue of flux is recommended); or Washing our Products by using water or water-soluble cleaning agents for cleaning residue after soldering
 - Use of the Products in places subject to dew condensation
- The Products are not subject to radiation-proof design.
- Please verify and confirm characteristics of the final or mounted products in using the Products.
- In particular, if a transient load (a large amount of load applied in a short period of time, such as pulse. is applied, confirmation of performance characteristics after on-board mounting is strongly recommended. Avoid applying power exceeding normal rated power; exceeding the power rating under steady-state loading condition may negatively affect product performance and reliability.
- De-rate Power Dissipation (Pd) depending on Ambient temperature (Ta). When used in sealed area, confirm the actual ambient temperature.
- Confirm that operation temperature is within the specified range described in the product specification.
- ROHM shall not be in any way responsible or liable for failure induced under deviant condition from what is defined in this document.

Precaution for Mounting / Circuit board design

- When a highly active halogenous (chlorine, bromine, etc.) flux is used, the residue of flux may negatively affect product performance and reliability.
- In principle, the reflow soldering method must be used; if flow soldering method is preferred, please consult with the ROHM representative in advance.

For details, please refer to ROHM Mounting specification

Precautions Regarding Application Examples and External Circuits

1. If change is made to the constant of an external circuit, please allow a sufficient margin considering variations of the characteristics of the Products and external components, including transient characteristics, as well as static characteristics.
2. You agree that application notes, reference designs, and associated data and information contained in this document are presented only as guidance for Products use. Therefore, in case you use such information, you are solely responsible for it and you must exercise your own independent verification and judgment in the use of such information contained in this document. ROHM shall not be in any way responsible or liable for any damages, expenses or losses incurred by you or third parties arising from the use of such information.

Precaution for Electrostatic

This Product is electrostatic sensitive product, which may be damaged due to electrostatic discharge. Please take proper caution in your manufacturing process and storage so that voltage exceeding the Products maximum rating will not be applied to Products. Please take special care under dry condition (e.g. Grounding of human body / equipment / solder iron, isolation from charged objects, setting of ionizer, friction prevention and temperature / humidity control).

Precaution for Storage / Transportation

1. Product performance and soldered connections may deteriorate if the Products are stored in the places where:
 - [a] the Products are exposed to sea winds or corrosive gases, including Cl₂, H₂S, NH₃, SO₂, and NO₂
 - [b] the temperature or humidity exceeds those recommended by ROHM
 - [c] the Products are exposed to direct sunshine or condensation
 - [d] the Products are exposed to high Electrostatic
2. Even under ROHM recommended storage condition, solderability of products out of recommended storage time period may be degraded. It is strongly recommended to confirm solderability before using Products of which storage time is exceeding the recommended storage time period.
3. Store / transport cartons in the correct direction, which is indicated on a carton with a symbol. Otherwise bent leads may occur due to excessive stress applied when dropping of a carton.
4. Use Products within the specified time after opening a humidity barrier bag. Baking is required before using Products of which storage time is exceeding the recommended storage time period.

Precaution for Product Label

QR code printed on ROHM Products label is for ROHM's internal use only.

Precaution for Disposition

When disposing Products please dispose them properly using an authorized industry waste company.

Precaution for Foreign Exchange and Foreign Trade act

Since our Products might fall under controlled goods prescribed by the applicable foreign exchange and foreign trade act, please consult with ROHM representative in case of export.

Precaution Regarding Intellectual Property Rights

1. All information and data including but not limited to application example contained in this document is for reference only. ROHM does not warrant that foregoing information or data will not infringe any intellectual property rights or any other rights of any third party regarding such information or data. ROHM shall not be in any way responsible or liable for infringement of any intellectual property rights or other damages arising from use of such information or data.:
2. No license, expressly or implied, is granted hereby under any intellectual property rights or other rights of ROHM or any third parties with respect to the information contained in this document.

Other Precaution

1. This document may not be reprinted or reproduced, in whole or in part, without prior written consent of ROHM.
2. The Products may not be disassembled, converted, modified, reproduced or otherwise changed without prior written consent of ROHM.
3. In no event shall you use in any way whatsoever the Products and the related technical information contained in the Products or this document for any military purposes, including but not limited to, the development of mass-destruction weapons.
4. The proper names of companies or products described in this document are trademarks or registered trademarks of ROHM, its affiliated companies or third parties.

General Precaution

1. Before you use our Products, you are requested to carefully read this document and fully understand its contents. ROHM shall not be in any way responsible or liable for failure, malfunction or accident arising from the use of any ROHM's Products against warning, caution or note contained in this document.
2. All information contained in this document is current as of the issuing date and subject to change without any prior notice. Before purchasing or using ROHM's Products, please confirm the latest information with a ROHM sales representative.
3. The information contained in this document is provided on an "as is" basis and ROHM does not warrant that all information contained in this document is accurate and/or error-free. ROHM shall not be in any way responsible or liable for any damages, expenses or losses incurred by you or third parties resulting from inaccuracy or errors of or concerning such information.