

AS3930

Single Channel Low Frequency Wakeup Receiver

General Description

The AS3930 is a single-channel low power ASK receiver that is able to generate a wake-up upon detection of a data signal which uses a LF carrier frequency between 110 - 150 kHz. The integrated correlator can be used for detection of a programmable 16-bit wake-up pattern.

The AS3930 provides a digital RSSI value, it supports a programmable data rate. The AS3930 offers a real-time clock (RTC), which is either derived from a crystal oscillator or the internal RC oscillator.

The programmable features of AS3930 enable to optimize its settings for achieving a longer distance while retaining a reliable wake-up generation. The sensitivity level of AS3930 can be adjusted in presence of a strong field or in noisy environments. The device is available in a 16-pin TSSOP and a 16-LD QFN (4x4) package.

[Ordering Information](#) and [Content Guide](#) appear at end of datasheet.

Key Benefits & Features

The benefits and features of AS3930, Single Channel Low Frequency Wakeup Receiver are listed below:

Figure 1:
Added Value of Using AS3930

Benefits	Features
Enables low power active tags	Single channel ASK wake-up receiver
Selectable carrier frequency	Carrier frequency range 110 – 150 kHz
Highly resistant to false wake-ups	16-bit programmable wake-up pattern
Improved immunity to false wake-ups	Supporting doubling of wake-up pattern
Allows frequency only detection	Wake-up without pattern detection selectable
Improved range with best-in-class sensitivity	Wake-up sensitivity 100µVRMS (typ.)
Adjustable range	Sensitivity level adjustable
Provides tracking of false wake-ups	False wake-up counter
Ensures wake-up in a noise environment	Periodical forced wake-up supported (1s – 2h)
Extended battery life	Current consumption in listening mode 1.37 µA (typ.)
Flexible clock configuration	RTC based 32 kHz XTAL, RC-OSC, or external clock

Benefits	Features
Operates from a 3V battery	Operating supply range 2.4V – 3.6V (TA = 25°C)
Industrial temperature range	Operation temperature range -40°C to +85°C

Applications

The AS3930, Single Channel Low Frequency Wakeup Receiver is ideal for Active RFID tags, real-time location systems, operator identification, access control, and wireless sensors.

Figure 2:
AS3930 Typical Application Diagram with Crystal Oscillator

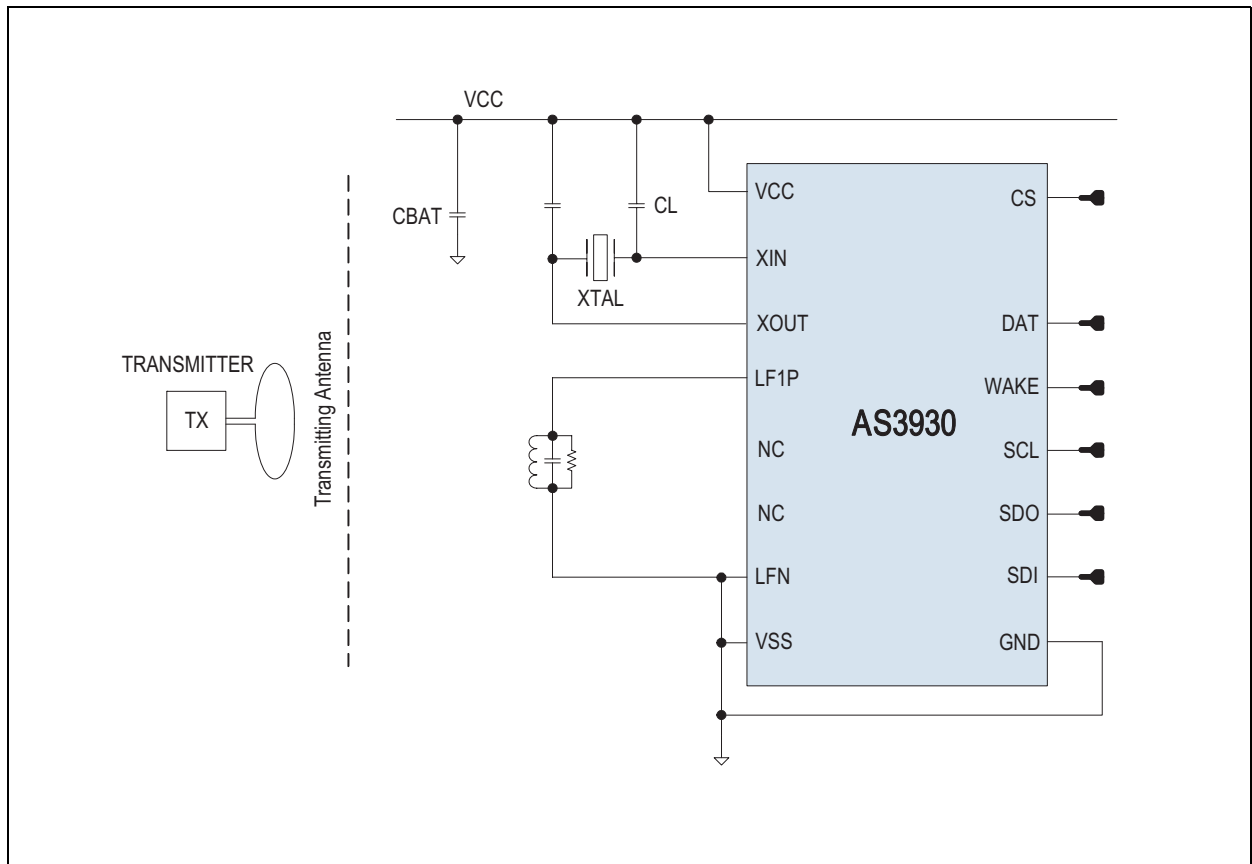

Figure 3:
AS3930 Typical Application Diagram without Crystal Oscillator

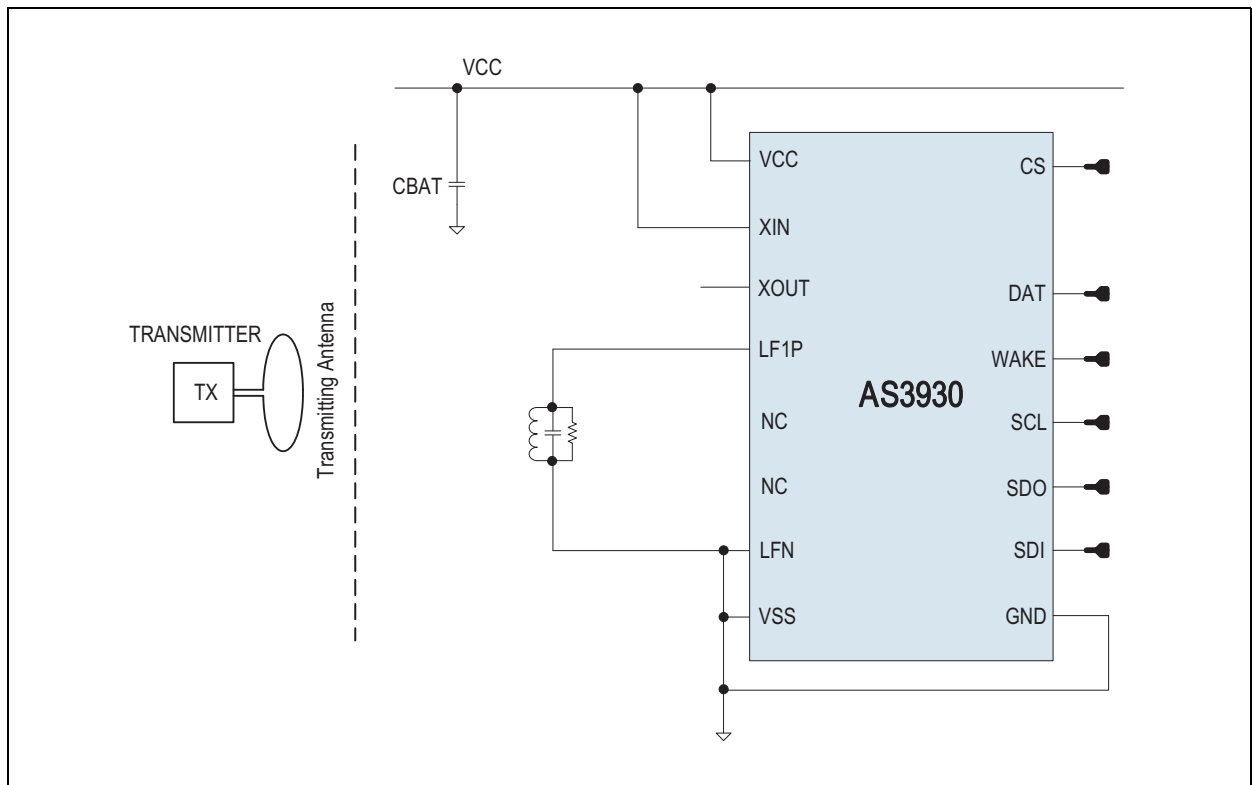
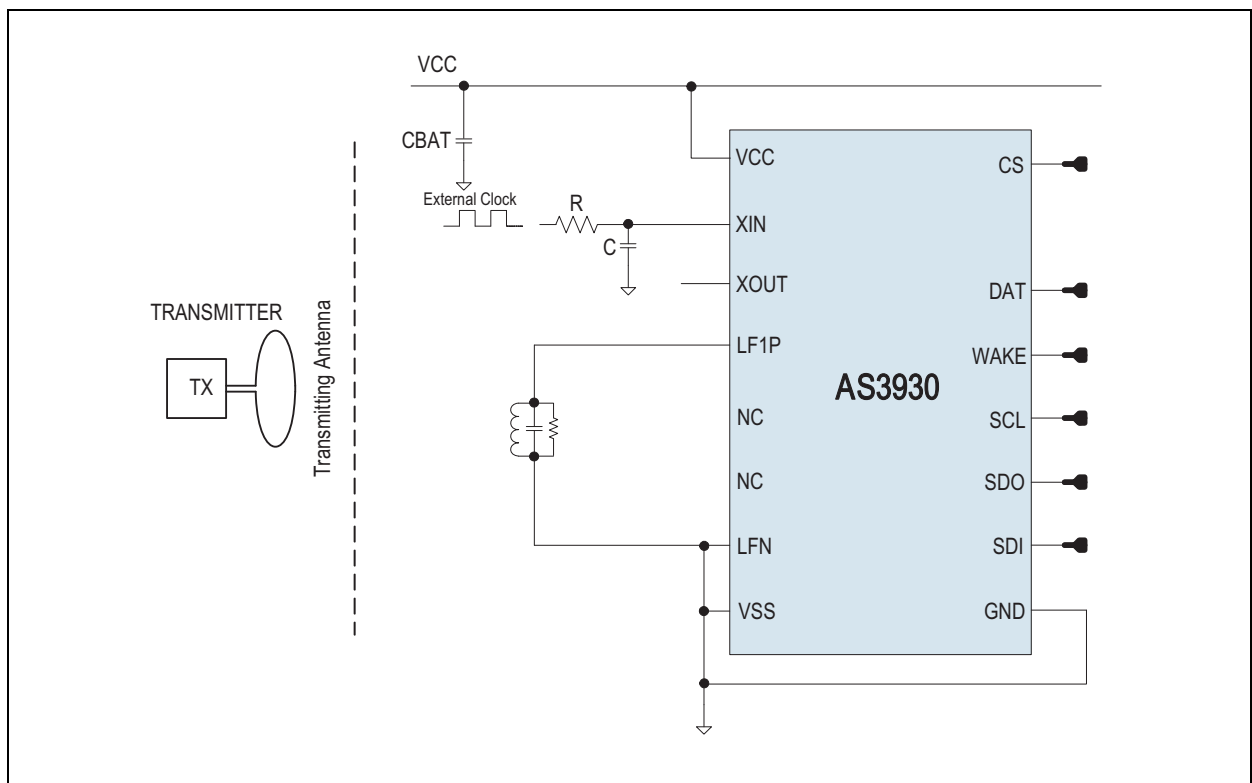

Figure 4:
AS3930 Typical Application Diagram with Clock from External Source



Pin Assignments

16-pin TSSOP

Figure 5:
Pin Diagram (Top View)

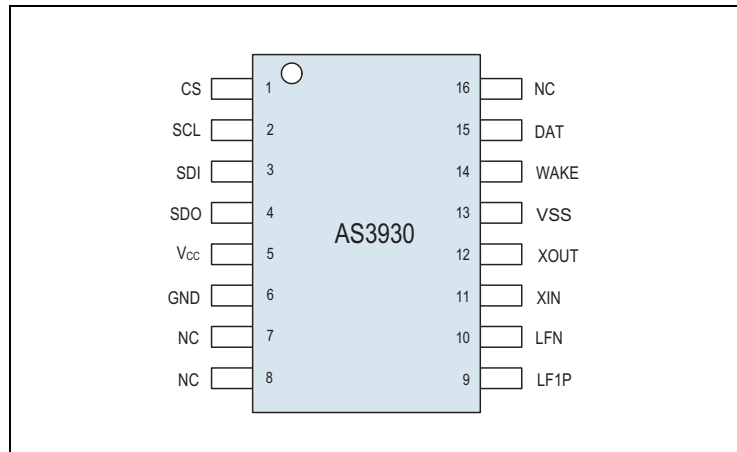
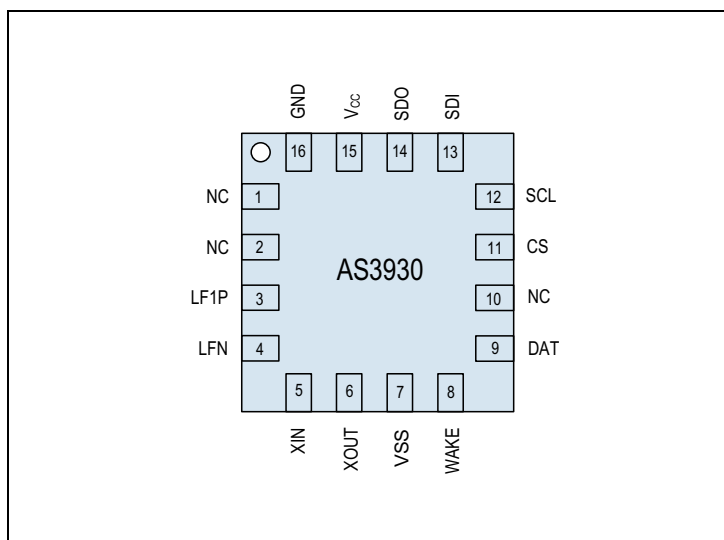

Figure 6:
Pin Description

Pin Number	Pin Name	Pin Type	Description
1	CS	Digital input	Chip select
2	SCL		SDI interface clock
3	SDI		SDI data input
4	SDO	Digital output / tristate	SDI data output (tristate when CS is low)
5	V _{CC}	Supply pad	Positive supply voltage
6	GND		Negative supply voltage
7	NC	-	Not Connected
8	NC		
9	LF1P	Analog I/O	Input antenna
10	LFN		Antenna ground
11	XIN		Crystal oscillator input
12	XOUT		Crystal oscillator output
13	V _{SS}	Supply pad	Substrate
14	WAKE	Digital output	Wake-up output IRQ
15	DAT		Data output
16	NC	-	Not connected

QFN 4x4 16 LD

Figure 7:
Pin Diagram (Top View)Figure 8:
Pin Description

Pin Number	Pin Name	Pin Type	Description
1	NC	-	Not connected
2	NC	-	
3	LF1P		Input antenna
4	LFN	Analog I/O	Antenna ground
5	XIN		Crystal oscillator input
6	XOUT		Crystal oscillator output
7	V _{SS}	Supply pad	Substrate
8	WAKE	Digital output	Wake-up output IRQ
9	DAT		Data output
10	NC	-	Not connected
11	CS	Digital input	Chip select
12	SCL		SDI interface clock
13	SDI		SDI data input
14	SDO	Digital output / tristate	SDI data output (tristate when CS is low)
15	V _{CC}	Supply pad	Positive supply voltage
16	GND		Negative supply voltage

Absolute Maximum Ratings

Stresses beyond those listed in [Absolute Maximum Ratings](#) may cause permanent damage to the device. These are stress ratings only. Functional operation of the device at these or any other conditions beyond those indicated in [Electrical Characteristics](#) is not implied. Exposure to absolute maximum rating conditions for extended periods may affect device reliability.

Figure 9:
Absolute Maximum Ratings

Parameter	Min	Max	Unit	Note
Electrical Parameters				
DC supply voltage (V_{DD})	-0.5	5	V	
Input pin voltage (V_{IN})	-0.5	5	V	
Input current (latch up immunity) (I_{SOURCE})	-100	100	mA	Norm: Jedec 78
Electrostatic Discharge				
Electrostatic discharge (ESD)	± 2		kV	Norm: MIL 883 E method 3015 (HBM)
Continuous Power Dissipation				
Total power dissipation (all supplies and outputs) (P_T)		0.07	mW	
Temperature Ranges and Storage Conditions				
Storage temperature (T_{strg})	-65	150	$^{\circ}\text{C}$	
Package body temperature (T_{body})		260	$^{\circ}\text{C}$	Norm: IPC/JEDEC J-STD-020 <i>The reflow peak soldering temperature (body temperature) is specified according IPC/JEDEC J-STD-020 "Moisture/Reflow Sensitivity Classification for Non-hermetic Solid State Surface Mount Devices".</i>
Humidity non-condensing	5	85	%	
Moisture Sensitivity Level (MSL)	3			Represents a maximum floor life time of 168h

Electrical Characteristics

Figure 10:
Electrical Characteristics

Symbol	Parameter	Conditions	Min	Typ	Max	Unit
Operating Conditions						
V_{DD}	Positive supply voltage		2.4		3.6	V
V_{SS}	Negative supply voltage		0		0	V
T_{AMB}	Ambient temperature		-40		85	°C
DC/AC Characteristics for Digital Inputs and Outputs						
CMOS Input						
V_{IH}	High level input voltage		0.58* V_{DD}	0.7* V_{DD}	0.83* V_{DD}	V
V_{IL}	Low level input voltage		0.125* V_{DD}	0.2* V_{DD}	0.3* V_{DD}	V
I_{LEAK}	Input leakage current				100	nA
CMOS Output						
V_{OH}	High level output voltage	With a load current of 1 mA	$V_{DD} - 0.4$			V
V_{OL}	Low level output voltage				$V_{SS} + 0.4$	V
C_L	Capacitive load	For a clock frequency of 1 MHz			400	pF
Tristate CMOS Output						
V_{OH}	High level output voltage	With a load current of 1 mA	$V_{DD} - 0.4$			V
V_{OL}	Low level output voltage				$V_{SS} + 0.4$	V
I_{OZ}	Tristate leakage current	To V_{DD} and V_{SS}			100	nA

Figure 11:
Electrical System Specifications

Symbol	Parameter	Conditions	Min	Typ	Max	Unit
Input Characteristics						
R_{IN}	Input Impedance	In case no antenna damper is set ($R1<4>=0$)		2		MΩ
Fmin	Minimum Input Frequency			110		kHz
Fmax	Maximum Input Frequency			150		kHz
Current Consumption						
IPWD	Power Down Mode			400		nA
ICHRC	Current Consumption in standard listening mode with channel active all the time and RC-oscillator as RTC			2.7		μA
ICHOORC	Current Consumption in ON/OFF mode and RC-oscillator as RTC	11% Duty Cycle		1.37		μA
		50% Duty Cycle		2		
ICHXT	Current Consumption in standard listening mode and crystal oscillator as RTC			3.5	5.9	μA
IDATA	Current Consumption in Preamble detection / Pattern correlation / Data receiving mode (RC-oscillator)	With 125 kHz carrier frequency and 1kbps data-rate. No load on the output pins.		5.3	9	μA
Input Sensitivity						
SENS	Input Sensitivity	With 125 kHz carrier frequency, chip in default mode, 4 half bits burst + 4 symbols preamble and single preamble detection		100		μVrms
Channel Settling Time						
TSAMP	Amplifier settling time			250		μs
Crystal Oscillator						
FXTAL	Frequency	Crystal dependent		32.768		kHz
TXTAL	Start-up Time				1	
IXTAL	Current consumption			1		μA

Symbol	Parameter	Conditions	Min	Typ	Max	Unit
External Clock Source						
IEXTCL	Current consumption			1		μA
RC Oscillator ⁽¹⁾						
FRCNCAL	Frequency	If no calibration is performed	27	32.768	42	kHz
FRCCAL32		If calibration with 32.768 kHz reference signal is performed	31	32.768	34.5	kHz
FRCCALMAX		Maximum achievable frequency after calibration		35		kHz
FRCCALMIN		Minimum achievable frequency after calibration		30		kHz
TRC	Start-up time	From RC enable (R1<0> = 0)			1	s
TCALRC	Calibration time				65	Periods of reference clock
IRC	Current consumption			200		nA

Note(s) and/or Footnote(s):

1. RC calibration is only successful after start-up is completed.

Typical Operating Characteristics

Figure 12:
Sensitivity over Voltage and Temperature

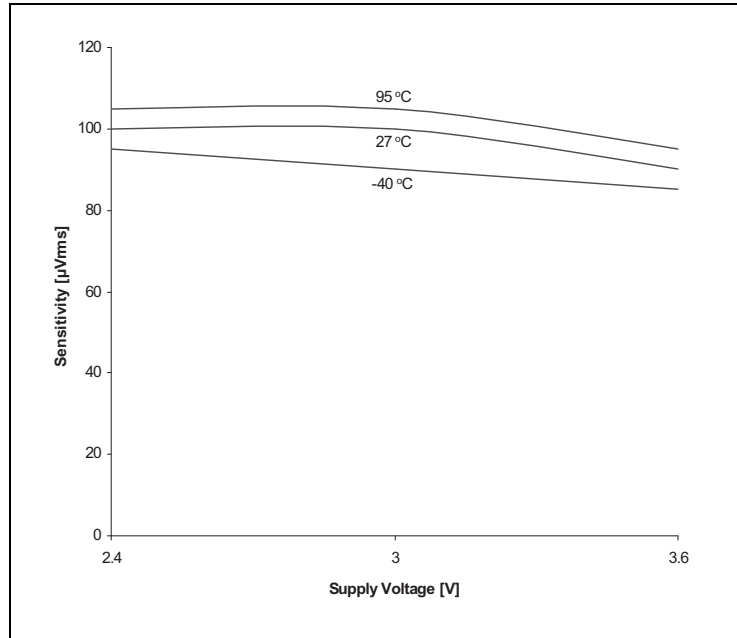

Figure 13:
Sensitivity over RSSI

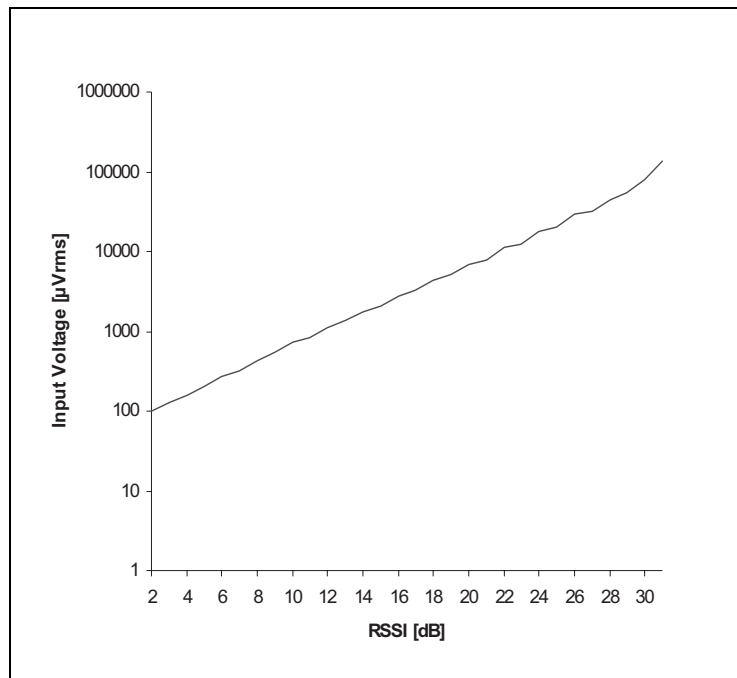

Figure 14:
RC-Oscillator Frequency over Voltage (calibr.)

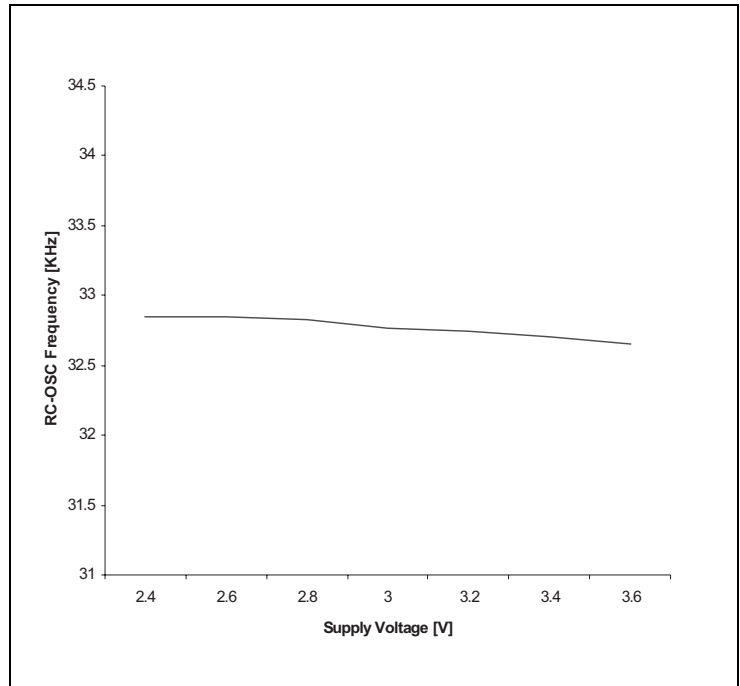
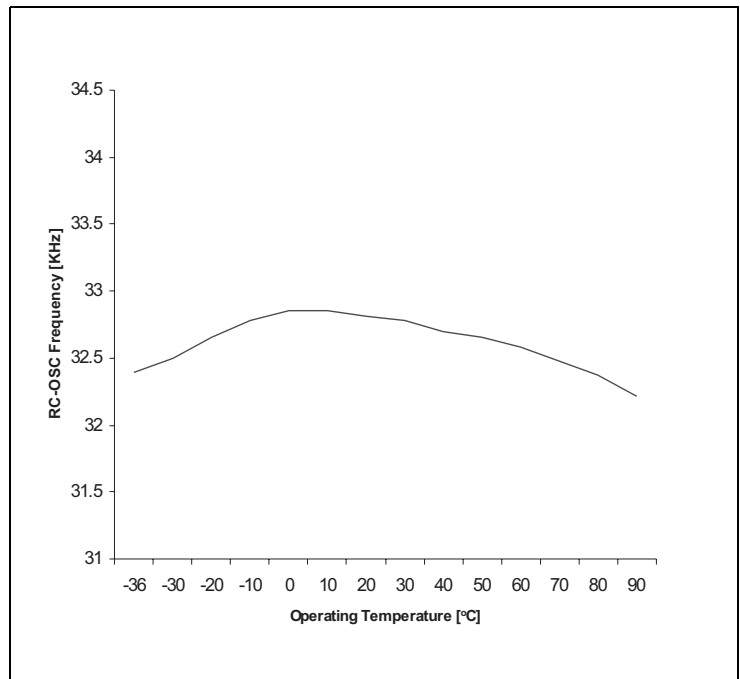

Figure 15:
RC-Oscillator Frequency over Temperature (calibr.)



Detailed Description

The AS3930 is a one-dimensional low power low-frequency wake-up receiver. The AS3930 is capable of detecting the presence of an inductive coupled carrier and extract the envelope of the ON-OFF-Keying (OOK) modulated carrier. In case the carrier is Manchester coded, then the clock is recovered from the transmitted signal and the data can be correlated with a programmed pattern. If the detected pattern corresponds to the stored one, then a wake-up signal (IRQ) is risen up. The pattern correlation can be bypassed in which case the wake-up detection is based only on the frequency detection.

The AS3930 is made up of a single receiving channel, one envelop detector, one data correlator, 8 programmable registers with the main logic and a real time clock.

The digital logic can be accessed by an SDI. The real time clock can be based on a crystal or on an internal RC. If the internal RC oscillator is used, a calibration procedure can be performed to improve its accuracy.

Figure 16:
Block Diagram of LF Wake-up Receiver AS3930

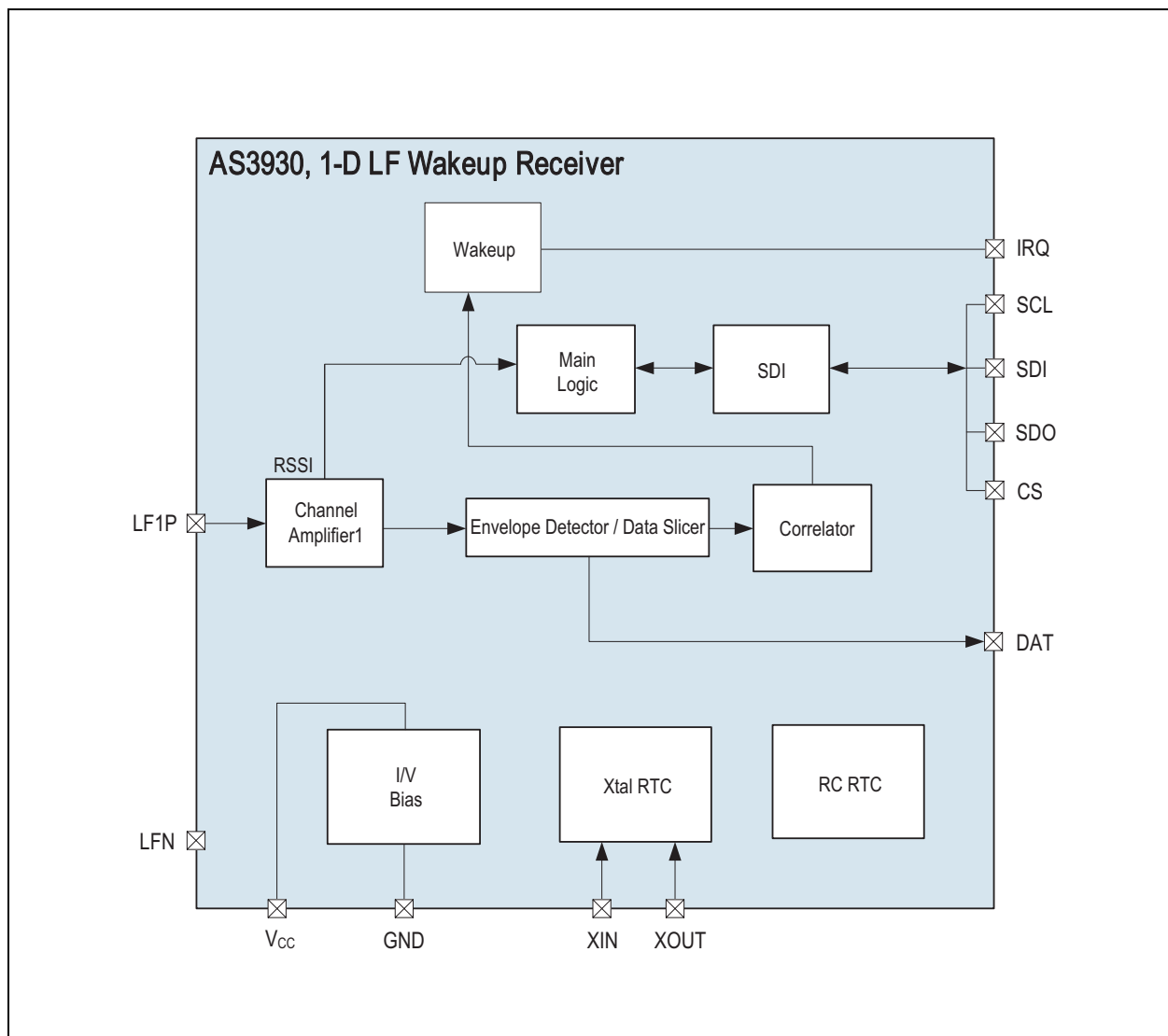

AS3930 needs the following external components:

- Power supply capacitor - CBAT - 100 nF.
- 32.768 kHz crystal with its two pulling capacitors - XTAL and CL - (it is possible to omit these components if the internal RC oscillator is used instead of the crystal oscillator).
- Input LC resonator.

In case the internal RC-oscillator is used (no crystal oscillator is mounted), the pin XIN has to be connected to the supply, while pin XOUT should stay floating. Application diagrams with and without crystal are shown in [Figure 2](#) and [Figure 3](#).

Operating Modes

Power Down Mode

In Power Down Mode AS3930 is completely switched OFF. The typical current consumption is 400 nA.

Listening Mode

In listening mode only the channel amplifier and the RTC are running. In this mode the system detects the presence of a carrier. In case the carrier is detected, the RSSI can be displayed. In this mode it is possible to distinguish the following three sub modes:

Standard Listening Mode

The channel amplifier that is capable of detecting the presence of the carrier frequency, is active all the time.

ON/OFF Mode (Low Power mode)

The channel amplifier is active for one millisecond after which it is switched OFF. The OFF-time is programmable (see [R4<7:6>](#)).

Figure 17:
ON/OFF Mode

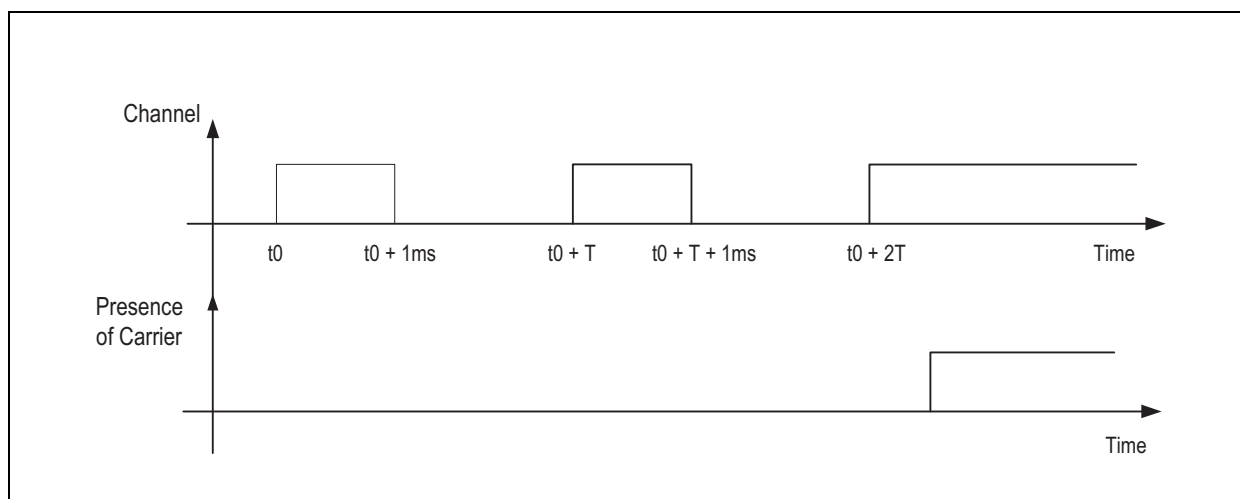

Further, for both sub modes, it is possible to enable a feature called Artificial Wake-up. If the Artificial Wake-up is enabled, then the AS3930 produces an interrupt after a certain time regardless of whether any activity is detected on the input. The period of the Artificial Wake-up is defined in the register [R8<2:0>](#). The user can distinguish between Artificial Wake-up and Wake-up based on the field detection (frequency or pattern detection) since the Artificial Wake-up interrupt lasts only 128µs. With this interrupt the microcontroller (µC) can get feedback on the surrounding environment (e.g. read the false wake-up register [R13<7:0>](#)) and/or take actions in order to change the setup.

Preamble Detection / Pattern Correlation

The preamble detection and pattern correlation are only considered for the wake-up when the data correlator function is enabled (see [R1<1>](#)). The correlator searches first for preamble frequency (constant frequency of Manchester clock defined according to bit-rate transmission, see [Figure 36](#)) and then for data pattern.

If the pattern is matched, then the wake-up interrupt is displayed on the WAKE output and the chip goes in data receiving mode. If the pattern fails, then the internal wake-up is terminated and no IRQ is produced.

Data Receiving

After a successful wake-up the chip enters the data receiving mode. In this mode the chip can be retained a normal OOK receiver. The received data are streamed out on the pin DAT. It is possible to put the chip back to listening mode either with a direct command (CLEAR_WAKE see [Figure 24](#)) or by using the timeout feature. This feature automatically sets the chip back to listening mode after a certain time [R7<7:5>](#).

System and Block Specification

Main Logic and SDI

Figure 18:
Register Table

	7	6	5	4	3	2	1	0
R0	N.A..		ON_OFF	Reserved			EN_A	PWD
R1	ABS_HY	AGC_TLIM	AGC_UD	ATT_ON	N.A.	EN_PAT2	EN_WPAT	EN_RTC
R2	S_ABSH	W_PAT_T<1:0>		Reserved			S_WU1<1:0>	
R3	HY_20m	HY_POS	FS_SLC<2:0>			FS_ENV<2:0>		
R4	T_OFF<1:0>		R_VAL<1:0>		GR<3:0>			
R5	TS2<7:0>							
R6	TS1<7:0>							
R7	T_OUT<2:0>			T_HBIT<4:0>				
R8	N.A.					T_AUTO<2:0>		
R9	N.A.	Reserved						
R10	N.A..			RSSI1<4:0>				
R11	N.A..							
R12	N.A..							
R13	F_WAKE							

Register Table Description and Default Values

Figure 19:
Description and Default Values of Registers

Register	Name	Type	Default Value	Description
R0<5>	ON_OFF	R/W	0	ON/OFF operation mode. (Duty-cycle defined in the register R4<7:6>)
R0<4>	MUX_123	R/W	0	Reserved (it is not allowed to set this bit to 1)
R0<3>	Reserved		1	Reserved
R0<2>	Reserved		1	Reserved
R0<1>	EN_A	R/W	1	Channel enable
R0<0>	PWD	R/W	0	Power down
R1<7>	ABS_HY	R/W	0	Data slicer absolute reference
R1<6>	AGC_TLIM	R/W	0	AGC acting only on the first carrier burst
R1<5>	AGC_UD	R/W	1	AGC operating in both direction (up-down)
R1<4>	ATT_ON	R/W	0	Antenna damper enable
R1<3>	Reserved		0	Reserved
R1<2>	EN_PAT2	R/W	0	Double wake-up pattern correlation
R1<1>	EN_WPAT	R/W	1	Data correlation enable
R1<0>	EN_RTC	R/W	1	Crystal oscillator enable
R2<7>	S_ABSH	R/W	0	Data slicer threshold reduction
R2<6:5>	W_PAT	R/W	00	Pattern correlation tolerance (see Figure 37)
R2<4:2>	Reserved		000	Reserved
R2<1:0>	S_WU1	R/W	00	Tolerance setting for the stage wake-up (see Figure 31)
R3<7>	HY_20m	R/W	0	Data slicer hysteresis if HY_20m = 0 then comparator hysteresis = 40mV if HY_20m = 1 then comparator hysteresis = 20mV
R3<6>	HY_POS	R/W	0	Data slicer hysteresis on both edges (HY_POS = 0 → hysteresis on both edges; HY_POS = 1 → hysteresis only on positive edges)
R3<5:3>	FS_SCL	R/W	100	Data slicer time constant (see Figure 35)
R3<2:0>	FS_ENV	R/W	000	Envelop detector time constant (see Figure 34)

Register	Name	Type	Default Value	Description	
R4<7:6>	T_OFF	R/W	00	OFF time in ON/OFF operation mode	
				T_OFF=00	1ms
				T_OFF=01	2ms
				T_OFF=10	4ms
				T_OFF=11	8ms
R4<5:4>	D_RES	R/W	01	Antenna damping resistor (see Figure 33)	
R4<3:0>	GR	R/W	0000	Gain reduction (see Figure 32)	
R5<7:0>	TS2	R/W	01101001	2 nd Byte of wake-up pattern	
R6<7:0>	TS1	R/W	10010110	1 st Byte of wake-up pattern	
R7<7:5>	T_OUT	R/W	000	Automatic time-out (see Figure 38)	
R7<4:0>	T_HBIT	R/W	01011	Bit rate definition (see Figure 36)	
R8<2:0>	T_AUTO	R/W	000	Artificial wake-up	
				T_AUTO=000	No artificial wake-up
				T_AUTO=001	1 sec
				T_AUTO=010	5 sec
				T_AUTO=011	20 sec
				T_AUTO=100	2 min
				T_AUTO=101	15min
				T_AUTO=110	1 hour
				T_AUTO=111	2 hour
R9<6:0>	Reserved		000000	Reserved	
R10<4:0>	RSSI1	R		RSSI channel	
R11<4:0>		R		N.A.	
R12<4:0>		R		N.A.	
R13<7:0>	F_WAK	R		False wake-up register	

Serial Data Interface (SDI)

This 4-wires interface is used by the Microcontroller (μ C) to program the AS3930. The maximum clock frequency of the SDI is 2MHz.

Figure 20:
Serial Data Interface (SDI) pins

Name	Signal	Signal Level	Description
CS	Digital Input with pull down	CMOS	Chip Select
SDI	Digital Input with pull down	CMOS	Serial Data input for writing registers, data to transmit and/or writing addresses to select readable register
SDO	Digital Output	CMOS	Serial Data output for received data or read value of selected registers
SCLK	Digital Input with pull down	CMOS	Clock for serial data read and write

Note(s): SDO is set to tristate if CS is low. In this way more than one device can communicate on the same SDO bus.

SDI Command Structure. To program the SDI the CS signal has to go high. A SDI command is made up by a two bytes serial command and the data is sampled on the falling edge of SCLK. [Figure 21](#) shows how the command looks like, from the MSB (B15) to LSB (B0). The command stream has to be sent to the SDI from the MSB (B15) to the LSB (B0).

Figure 21:
SDI Command Structure

Mode		Register address / Direct Command						Register Data						
B15	B14	B13	B12	B11	B10	B9	B8	B7	B6	B5	B3	B2	B1	B0

The first two bits (B15 and B14) define the operating mode. There are three modes available (write, read, direct command) plus one spare (not used), as shown in [Figure 22](#).

Figure 22:
Bits B15, B14

B15	B14	Mode
0	0	WRITE
0	1	READ
1	0	NOT ALLOWED
1	1	DIRECT COMMAND

In case a write or read command happens the next 6 bits (B13 to B8) define the register address which has to be written respectively read, as shown in [Figure 23](#).

Figure 23:
Bits B13-B8

B13	B12	B11	B10	B9	B8	Read/Write register
0	0	0	0	0	0	R0
0	0	0	0	0	1	R1
0	0	0	0	1	0	R2
0	0	0	0	1	1	R3
0	0	0	1	0	0	R4
0	0	0	1	0	1	R5
0	0	0	1	1	0	R6
0	0	0	1	1	1	R7
0	0	1	0	0	0	R8
0	0	1	0	0	1	R9
0	0	1	0	1	0	R10
0	0	1	0	1	1	R11
0	0	1	1	0	0	R12
0	0	1	1	0	1	R13

The last 8 bits are the data that has to be written respectively read. A CS toggle high-low-high terminates the command mode.

If a direct command is sent (B15-B14=11) the bits from B13 to B8 defines the direct command while the last 8 bits are omitted. [Figure 24](#) shows all possible direct commands:

Figure 24:
List of Direct Commands

COMMAND_MODE	B13	B12	B11	B10	B9	B8
clear_wake	0	0	0	0	0	0
reset_RSSI	0	0	0	0	0	1
trim_osc	0	0	0	0	1	0
clear_false	0	0	0	0	1	1
preset_default	0	0	0	1	0	0

All direct commands are explained below:

- **clear_wake:** Clears the wake state of the chip. In case the chip has woken up (WAKE pin is high) the chip is set back to listening mode.
- **reset_RSSI:** Resets the RSSI measurement.
- **trim_osc:** Starts the trimming procedure of the internal RC oscillator (see Figure 45).
- **clear_false:** Resets the false wake-up register (R13<7:0>=00).
- **preset_default:** Sets all register in the default mode, as shown in Figure 19.

Note(s): In order to get the AS3930 work properly after sending the preset_default direct command, it is mandatory to write R0<3>=0 and R0<2>=0.

Writing of Data to Addressable Registers (WRITE Mode).

The SDI is sampled at the falling edge of SCLK (as shown in the following diagrams).

A CS toggling high-low-high indicates the end of the WRITE command after register has been written. The following example shows a write command.

Figure 25:
Writing of a Single Byte (falling edge sampling)

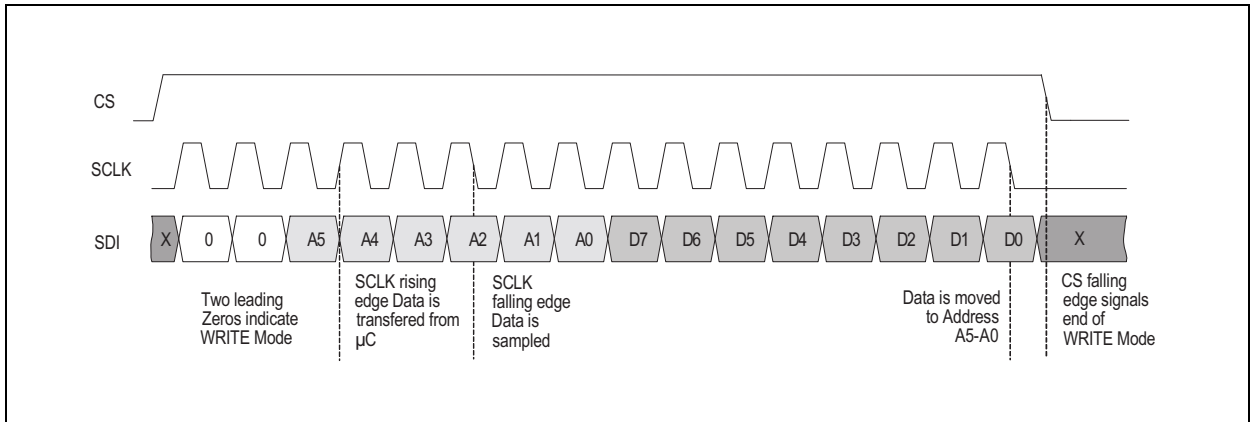
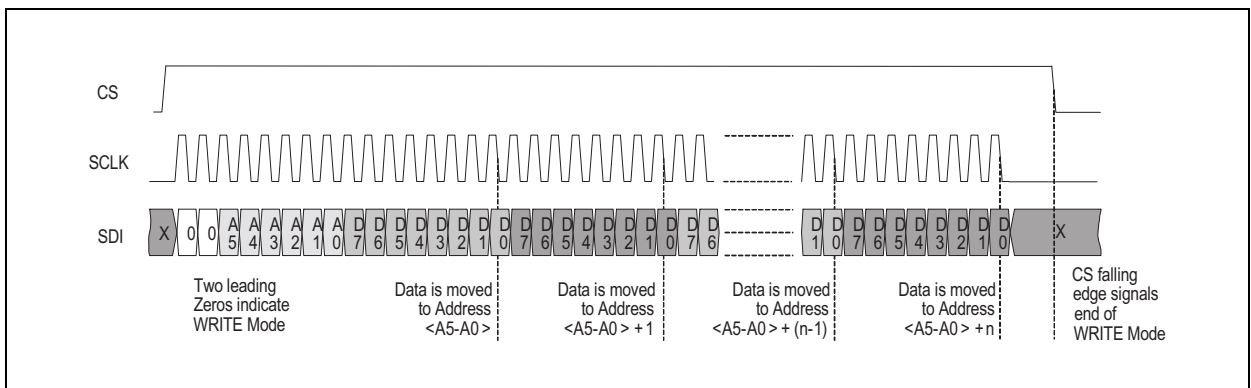

Figure 26:
Writing of Register Data with Auto-incrementing Address



Reading of Data from Addressable Registers (READ Mode).

Once the address has been sent through SDI, the data can be fed through the SDO pin out to the microcontroller.

A CS LOW toggling high-low-high has to be performed after finishing the read mode session, in order to indicate the end of the READ command and prepare the Interface to the next command control Byte.

To transfer bytes from consecutive addresses, SDI master has to keep the CS signal high and the SCLK clock has to be active as long as data need to be read.

Figure 27:
Reading of Single Register Byte

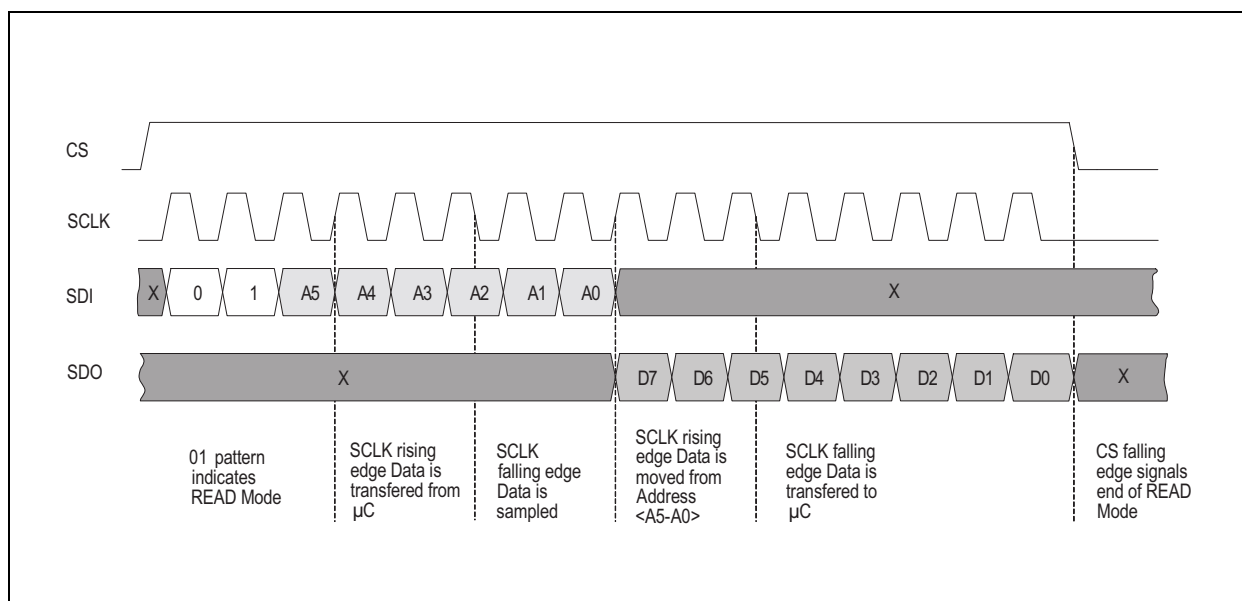
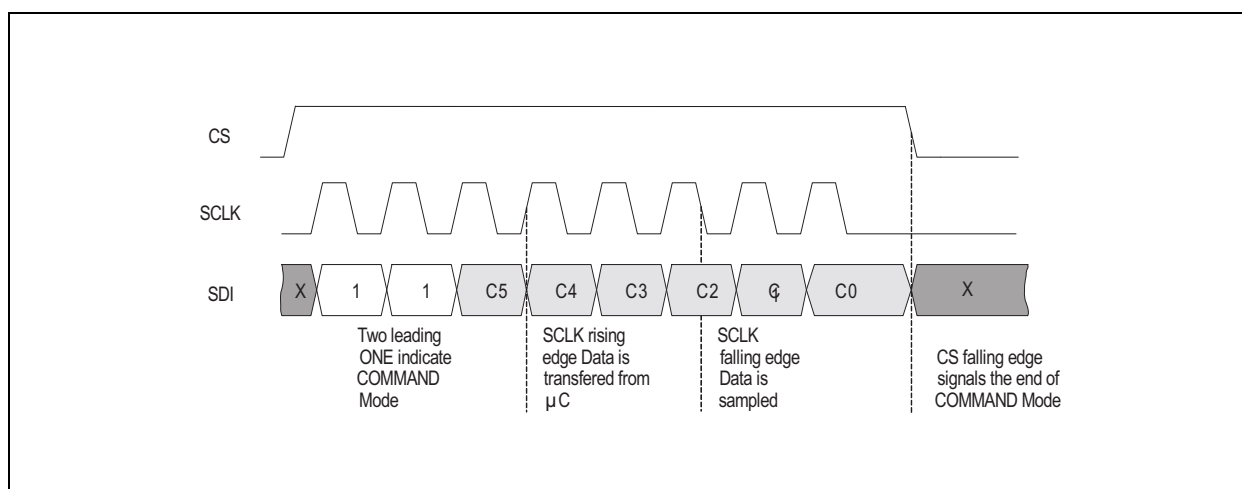

Figure 28:
Send Direct COMMAND Byte



SDI Timing

Figure 29:
SDI Timing Parameters

Symbol	Parameter	Min	Typ	Max	Units
TCCLK	Time CS to Sampling Data	500			ns
TDCLK	Time Data to Sampling Data	300			ns
THCL	SCLK High Time	200			ns
TCLK	SCLK period	500			ns
TCLKCS	Time Sampling Data to CS down	500			ns
TCST	CS Toggling time	500			ns

Figure 30:
SDI Timing Diagram

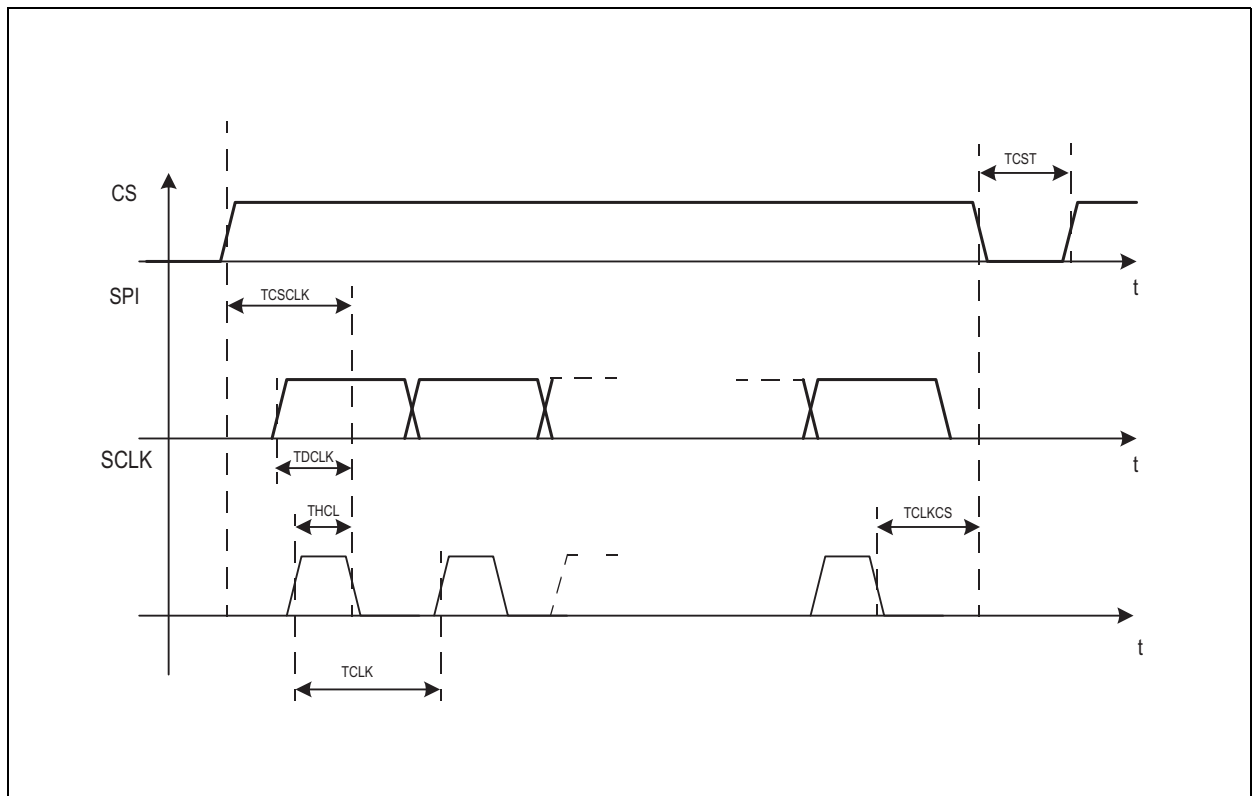

Channel Amplifier and Frequency Detector

The channel amplifier consists of a variable gain amplifier (VGA), an automatic gain control, and a frequency detector. The latter detects the presence of a carrier. As soon as the carrier is detected the AGC is enabled, the gain of the VGA is reduced and set to the right value and the RSSI can be displayed.

Frequency Detector / AGC

The frequency detection uses the RTC as time base. In case the internal RC oscillator is used as RTC, it must be calibrated, but the calibration is guaranteed for a 32.768 kHz crystal oscillator only. The frequency detection criteria can be tighter or more relaxed according to the setup described in [R2<1:0>](#) (see [Figure 31](#)).

Figure 31:
Tolerance Settings for Wake-up

R2<1>	R2<0>	Tolerance
0	0	Relaxed
0	1	Tighter (Medium)
1	0	Stringent
1	1	Reserved

The AGC can operate in two modes:

- AGC down only ([R1<5>](#)=0)
- AGC up and down ([R1<5>](#)=1)

As soon as the AGC starts to operate, the gain in the VGA is set to maximum. If the AGC down only mode is selected, the AGC can only decrease the gain. Since the RSSI is directly derived from the VGA gain, the system holds the RSSI peak.

When the AGC up and down mode is selected, the RSSI can follow the input signal strength variation in both directions.

Regardless which AGC operation mode is used, the AGC needs maximum 35 carrier periods to settle.

The RSSI is stored in the register [R10<4:0>](#).

Both AGC modes (only down or down and up) can also operate with time limitation. This option allows AGC operation only in time slot of 256µs following the internal wake-up. Then the AGC (RSSI) is frozen till the wake-up or RSSI reset occurs.

The RSSI is reset either with the direct command 'clear_wakeup' or 'reset_RSSI'. The 'reset_RSSI' command resets only the AGC setting but does not terminate wake-up condition. This means that if the signal is still present the new AGC setting (RSSI) will appear not later than 300µs (35 LF carrier periods) after the command was received. The AGC setting is reset if for duration of 3 Manchester half symbols no carrier is detected. If the wake-up IRQ is cleared the chip will go back to listening mode.

In case the maximum amplification at the beginning is a drawback (e.g. in noisy environment) it is possible to set a smaller starting gain on the amplifier [Figure 32](#). In this way it is possible to reduce the false frequency detection.

Figure 32:
Bit Setting of Gain Reduction

R4<3>	R4<2>	R4<1>	R4<0>	Gain Reduction
0	0	0	0	No gain reduction
0	0	0	1	N.A..
0	0	1	0 or 1	N.A..
0	1	0	0 or 1	-4dB
0	1	1	0 or 1	-8dB
1	0	0	0 or 1	-12dB
1	0	1	0 or 1	-16dB
1	1	0	0 or 1	-20dB
1	1	1	0 or 1	-24dB

Antenna Damper

The antenna damper allows the chip to deal with higher field strength, it is enabled by register R1<4>. It consists of shunt resistors which degrade the quality factor of the resonator by reducing the signal at the input of the amplifier. In this way the resonator sees a smaller parallel resistance (in the band of interest) which degrades its quality factor in order to increase the linear range of the channel amplifier (the amplifier doesn't saturate in presence of bigger signals). Figure 33 shows the bit setup.

Figure 33:
Antenna Damper Bit Setup

R4<5>	R4<4>	Shunt resistor (parallel to the resonator at 125 kHz)
0	0	1 kΩ
0	1	3 kΩ
1	0	9 kΩ
1	1	27 kΩ

Demodulator / Data Slicer

The performance of the demodulator can be optimized according to bit rate and preamble length as described in [Figure 34](#) and [Figure 35](#).

Figure 34:
Bit Setup for Envelop Detector for Different Symbol Rates

R3<2>	R3<1>	R3<0>	Symbol Rate [Manchester symbol/s]
0	0	0	4096
0	0	1	2184
0	1	0	1490
0	1	1	1130
1	0	0	910
1	0	1	762
1	1	0	655
1	1	1	512

If the bit rate gets higher, the time constant in the envelop detector must be set to a smaller value. This means that higher noise is injected because of the wider band. The next table is a rough indication of how the envelop detector looks like for different bit rates. By using proper data slicer settings it is possible to improve the noise immunity paying the penalty of a longer preamble. In fact if the data slicer has a bigger time constant it is possible to reject more noise, but every time a transmission occurs, the data slicer need time to settle. This settling time will influence the length of the preamble. [Figure 35](#) gives a correlation between data slicer setup and minimum required preamble length.

Figure 35:
Bit Setup for Data Slicer for Different Preamble Length

R3<5>	R3<4>	R3<3>	Minimum Preamble Length [ms]
0	0	0	0.8
0	0	1	1.15
0	1	0	1.55
0	1	1	1.9
1	0	0	2.3
1	0	1	2.65
1	1	0	3
1	1	1	3.5

Note(s): These times are minimum required, but it is recommended to prolong the preamble.

The comparator of the data slicer can work only with positive or with symmetrical threshold R3<6>. In addition the threshold can be 20 or 40 mV R3<7>. In case the length of the preamble is an issue the data slicer can also work with an absolute threshold R1<7>. In this case the bits R3<2:0> would not influence the performance. It is even possible to reduce the absolute threshold in case the environment is not particularly noisy R2<7>.

Correlator

After frequency detection the data correlation is only performed if the correlator is enabled (R1<1>=1).

The data correlation consists of checking the presence of a preamble (ON/OFF modulated carrier) followed by a certain pattern.

After the frequency detection the correlator waits 16 bits (see bit rate definition in Figure 36) and if no preamble is detected the chip is set back to listening mode and the false wake-up register (R13<7:0>) is incremented by one.

To get started with the pattern correlation the correlator needs to detect at least 4 bits of the preamble (ON/OFF modulated carrier).

The bit duration is defined in the register R7<4:0>(Figure 36) as function of the Real Time Clock (RTC) periods.

Figure 36:
Bit Rate Setup

R7 <4>	R7 <3>	R7 <2>	R7 <1>	R7 <0>	Bit Duration in RTC Clock Periods	Bit Rate (bits/s)	Symbol Rate (Manchester symbols/s)
0	0	0	1	1	4	8192	4096
0	0	1	0	0	5	6552	3276
0	0	1	0	1	6	5460	2730
0	0	1	1	0	7	4680	2340
0	0	1	1	1	8	4096	2048
0	1	0	0	0	9	3640	1820
0	1	0	0	1	10	3276	1638
0	1	0	1	0	11	2978	1489
0	1	0	1	1	12	2730	1365
0	1	1	0	0	13	2520	1260
0	1	1	0	1	14	2340	1170
0	1	1	1	0	15	2184	1092
0	1	1	1	1	16	2048	1024
1	0	0	0	0	17	1926	963
1	0	0	0	1	18	1820	910
1	0	0	1	0	19	1724	862
1	0	0	1	1	20	1638	819
1	0	1	0	0	21	1560	780
1	0	1	0	1	22	1488	744
1	0	1	1	0	23	1424	712
1	0	1	1	1	24	1364	682
1	1	0	0	0	25	1310	655
1	1	0	0	1	26	1260	630
1	1	0	1	0	27	1212	606
1	1	0	1	1	28	1170	585
1	1	1	0	0	29	1128	564
1	1	1	0	1	30	1092	546
1	1	1	1	0	31	1056	528
1	1	1	1	1	32	1024	512

If the preamble is detected correctly the correlator keeps searching for a data pattern. The duration of the preamble plus the pattern should not be longer than 40 bits (see bit rate definition in [Figure 36](#)). The data pattern can be defined by the user and consists of two bytes which are stored in the registers [R5<7:0>](#) and [R6<7:0>](#). The two bytes define the pattern consisting of 16 half bit periods. This means the pattern and the bit period can be selected by the user. The only limitation is that the pattern (in combination with preamble) must obey Manchester coding and timing. It must be noted that according to Manchester coding a down-to-up bit transition represents a symbol "0", while a transition up-to-down represents a symbol "1". If the default code is used (96 [hex]) the binary code is (10 01 01 10 01 10 10 01). MSB has to be transmitted first.

The user can also select ([R1<2>](#)) if single or double data pattern is used for wake-up. In case double pattern detection is set, the same pattern has to be repeated 2 times.

Additionally it is possible to set the number of allowed missing zero bits (not symbols) in the received bitstream ([R2<6:5>](#)), as shown in the [Figure 37](#).

Figure 37:
Allowed Pattern Detection Errors

R2<6>	R2<5>	Maximum allowed error in the pattern detection
0	0	No error allowed
0	1	1 missed zero
1	0	2 missed zeros
1	1	3 missed zeros

If the pattern matches the wake-up, interrupt is displayed on the WAKE output.

If the pattern detection fails, the internal wake-up (on all active channels) is terminated with no signal sent to MCU and the false wake-up register will be incremented ([R13<7:0>](#)).

The wake-up state is terminated with the direct command 'clear_wake' (see [Figure 24](#)). This command terminates the MCU activity. The termination can also be automatic in case there is no response from MCU. The time out for automatic termination is set in a register [R7<7:5>](#), as shown in the [Figure 38](#).

Figure 38:
Timeout Setup

R7<7>	R7<6>	R7<5>	Time out
0	0	0	0 sec
0	0	1	50 msec
0	1	0	100 msec
0	1	1	150 msec
1	0	0	200 msec
1	0	1	250 msec
1	1	0	300 msec
1	1	1	350 msec

Wake-up Protocol - Carrier Frequency 125 kHz
Without Pattern Detection

Figure 39:
Wake-up Protocol Overview without Pattern Detection (only carrier frequency detection)

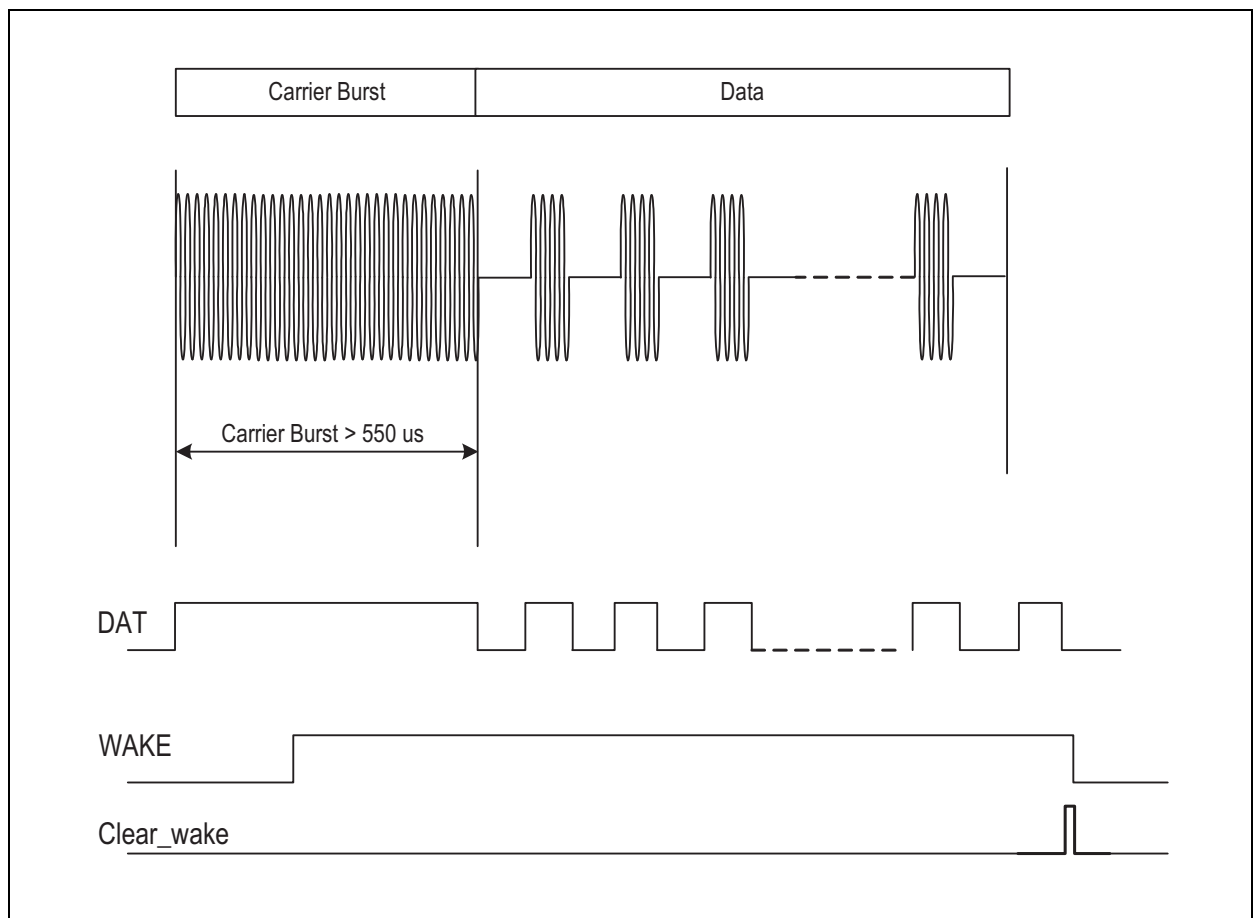

In case the data correlation is disabled ($R1<1>=0$) the AS3930 wakes up upon detection of the carrier frequency only as shown in Figure 39. In order to ensure that AS3930 wakes up the carrier burst has to last longer than 550 μ s. To set AS3930 back to listening mode there are two possibilities: either the microcontroller sends the direct command clear_wake via SDI or the time out option is used ($R7<7:5>$). In case the latter is chosen, AS3930 is automatically set to listening mode after the time defined in T_OUT ($R7<7:5>$), counting starts at the low-to-high WAKE edge on the WAKE pin.

Single Pattern Detection

The Figure 40 shows the wake-up protocol in case the pattern correlation is enabled ($R1<1>=1$) for a 125 kHz carrier frequency. The initial carrier burst has to be longer than 550 μ s and can last maximum 16 bits (see bit rate definition in Figure 36). If the ON/OFF mode is used ($R1<5>=1$), the minimum value of the maximum carrier burst duration is limited to 10 ms. This is summarized in Figure 41. In case the carrier burst is too long the internal wake-up will be set back to low and the false wake-up counter ($R13<7:0>$) will be incremented by one.

The carrier burst must be followed by a preamble (0101... modulated carrier with a bit duration defined in Figure 36) and the wake-up pattern stored in the registers $R5<7:0>$ and $R6<7:0>$. The preamble must have at least 4 bits and the preamble duration together with the pattern should not be longer than 40 bits. If the wake-up pattern is correct, the signal on the WAKE pin goes high one bit after the end of the pattern and the data transmission can get started. To set the chip back to listening mode the direct command clear_wake, as well as the time out option ($R7<7:5>$) can be used.

Figure 40:
Wake-up Protocol Overview with Single Pattern Detection

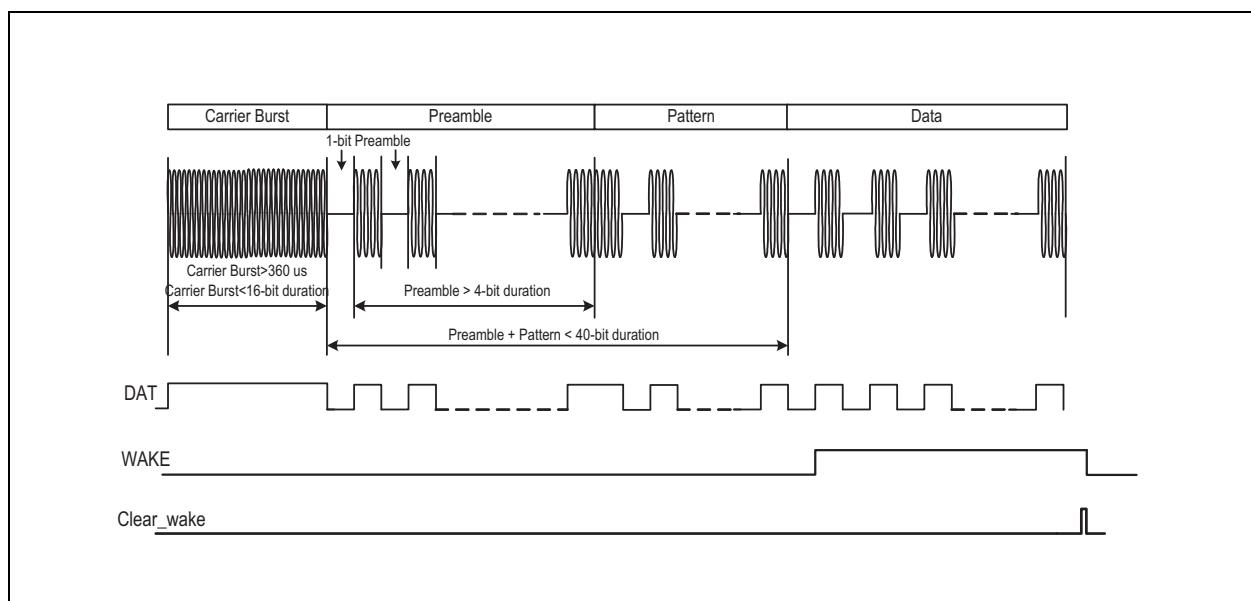

Figure 41:
Preamble Requirements in Standard Mode, Scanning Mode and ON/OFF Mode

Bit Rate (bits/s)	Maximum Duration of the Carrier Burst in Standard Mode and Scanning Mode (ms)	Maximum Duration of the Carrier Burst in ON/OFF Mode (ms)
8192	1.95	10
6552	2.44	10
5460	2.93	10
4680	3.41	10
4096	3.90	10
3640	4.39	10
3276	4.88	10
2978	5.37	10
2730	5.86	10
2520	6.34	10
2340	6.83	10
2184	7.32	10
2048	7.81	10
1926	8.30	10
1820	8.79	10
1724	9.28	10
1638	9.76	10
1560	10.25	10.25
1488	10.75	10.75
1424	11.23	11.23
1364	11.73	11.73
1310	12.21	12.21
1260	12.69	12.69
1212	13.20	13.20
1170	13.67	13.67
1128	14.18	14.18
1092	14.65	14.65
1056	15.15	15.15
1024	15.62	15.62

False Wake-up Register

The wake-up strategy in the AS3930 is based on 2 steps:

1. **Frequency Detection:** In this phase the frequency of the received signal is checked.
2. **Pattern Correlation:** Here the pattern is demodulated and checked whether it corresponds to the valid one.

If there is a disturber or noise capable to overcome the first step (frequency detection) without producing a valid pattern, then a false wake-up call happens. Each time this event is recognized a counter is incremented by one and the respective counter value is stored in a memory cell (false wake-up register). Thus, the microcontroller can periodically look at the false wake-up register, to get a feeling how noisy the surrounding environment is and can then react accordingly (e.g. reducing the gain of the LNA during frequency detection, set the AS3930 temporarily to power down etc.), as shown in the Figure 42. The false wake-up counter is a useful tool to quickly adapt the system to any changes in the noise environment and thus avoid false wake-up events.

Most wake-up receivers have to deal with environments that can rapidly change. By periodically monitoring the number of false wake-up events it is possible to adapt the system setup to the actual characteristics of the environment and enables a better use of the full flexibility of AS3930.

Figure 42:
Concept of the False Wake-up Register Together with System

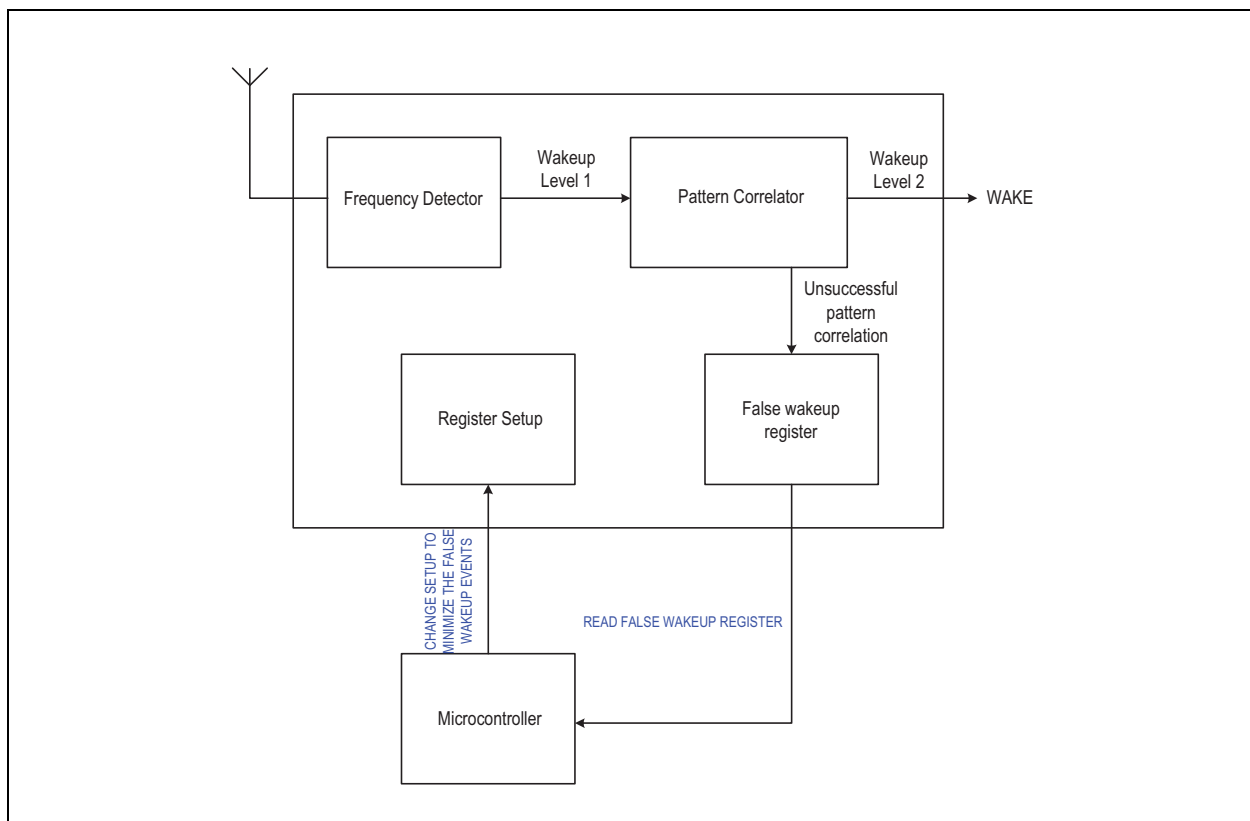

Real Time Clock (RTC)

The RTC can be based on a crystal oscillator ($R1<0>=1$), the internal RC-oscillator ($R1<0>=0$), or an external clock source ($R1<0>=1$). The crystal has higher precision of the frequency but a higher current consumption and needs three external components (crystal plus two capacitors). The RC-oscillator is completely integrated and can be calibrated if a reference signal is available for a very short time to improve the frequency accuracy. The calibration gets started with the trim_osc direct command. Since no non-volatile memory is available the calibration must be done every time after the RCO was turned OFF. The RCO is turned OFF when the chip is in power down mode, a POR happened, or the crystal oscillator is enabled. Since the RTC defines the time base of the frequency detection, the selected frequency (frequency of the crystal oscillator or the reference frequency used for calibration of the RC oscillator) should be about one fourth of the carrier frequency:

$$(EQ1) \quad F_{RTC} \sim F_{CAR} * 0.25$$

Where:

F_{CAR} is the carrier frequency

F_{RTC} is the RTC frequency

Note(s): The third option for the RTC is the use of an external clock source, which must be applied directly to the XIN pin (XOUT floating).

Crystal Oscillator

Figure 43:
Characteristics of XTAL

Parameter	Conditions	Min	Typ	Max	Units
Crystal accuracy (initial)	Overall accuracy			±120	p.p.m.
Crystal motional resistance				60	KΩ
Frequency			32.768		kHz
Contribution of the oscillator to the frequency error			±5		p.p.m
Start-up Time	Crystal dependent		1		s
Duty cycle		45	50	55	%
Current consumption			1		μA

RC-Oscillator

Figure 44:
Characteristics of RCO

Parameter	Conditions	Min	Typ	Max	Units
Frequency	If no calibration is performed	27	32.768	42	kHz
	If calibration is performed	31	32.768	34.5	kHz
Calibration time	Periods of reference clock			65	cycles
Current consumption			200		nA

To trim the RC-Oscillator, set the chip select (CS) to high before sending the direct command trim_osc over SDI. Then 65 digital clock cycles of the reference clock (e.g. 32.768 kHz) have to be sent on the clock bus (SCLK), as shown in Figure 45. After that the signal on the chip select (CS) has to be pulled down.

The calibration is effective after the 65th reference clock edge and it will be stored in a volatile memory. In case the RC-oscillator is switched OFF or a power-ON-reset happens (e.g. battery change) the calibration has to be repeated.

Figure 45:
RC-Oscillator Calibration via SDI

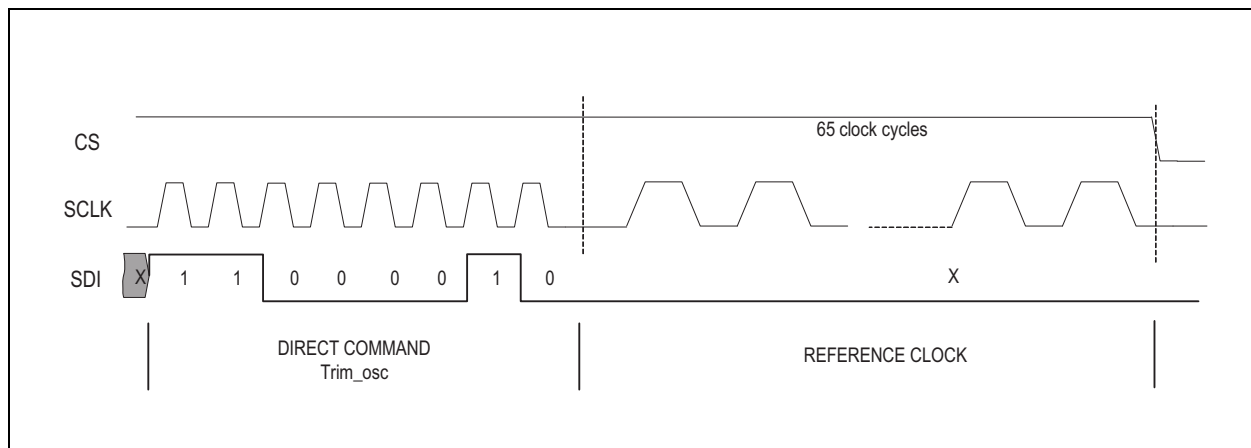

External Clock Source

To clock the AS3930 with an external signal the crystal oscillator has to be enabled ($R1<0>=1$). As shown in the Figure 4 the clock must be applied on the pin XIN while the pin XOUT must stay floating. The RC time constant has to be 100µs with a tolerance of ±10% (e.g. R=680 kΩ and C=22pF). In the Figure 46 the clock characteristics are summarized.

Figure 46:
Characteristics of External Clock

Symbol	Parameter	Min	Typ	Max	Units
Vl	Low level	0		$0.1 * V_{DD}$	V
Vh	High level	$0.9 * V_{DD}$		V_{DD}	V
Tr	Rise-time			3	μs
Tf	Fall-time			3	μs
$T = 1/2\pi RC$	RC Time constant	90	100	110	μs

Note(s): In power down mode the external clock has to be set to V_{DD} .

Package Drawings & Markings

The product is available in a 16-pin TSSOP and QFN 4x4 16 LD package.

Figure 47:
16-pin TSSOP Package

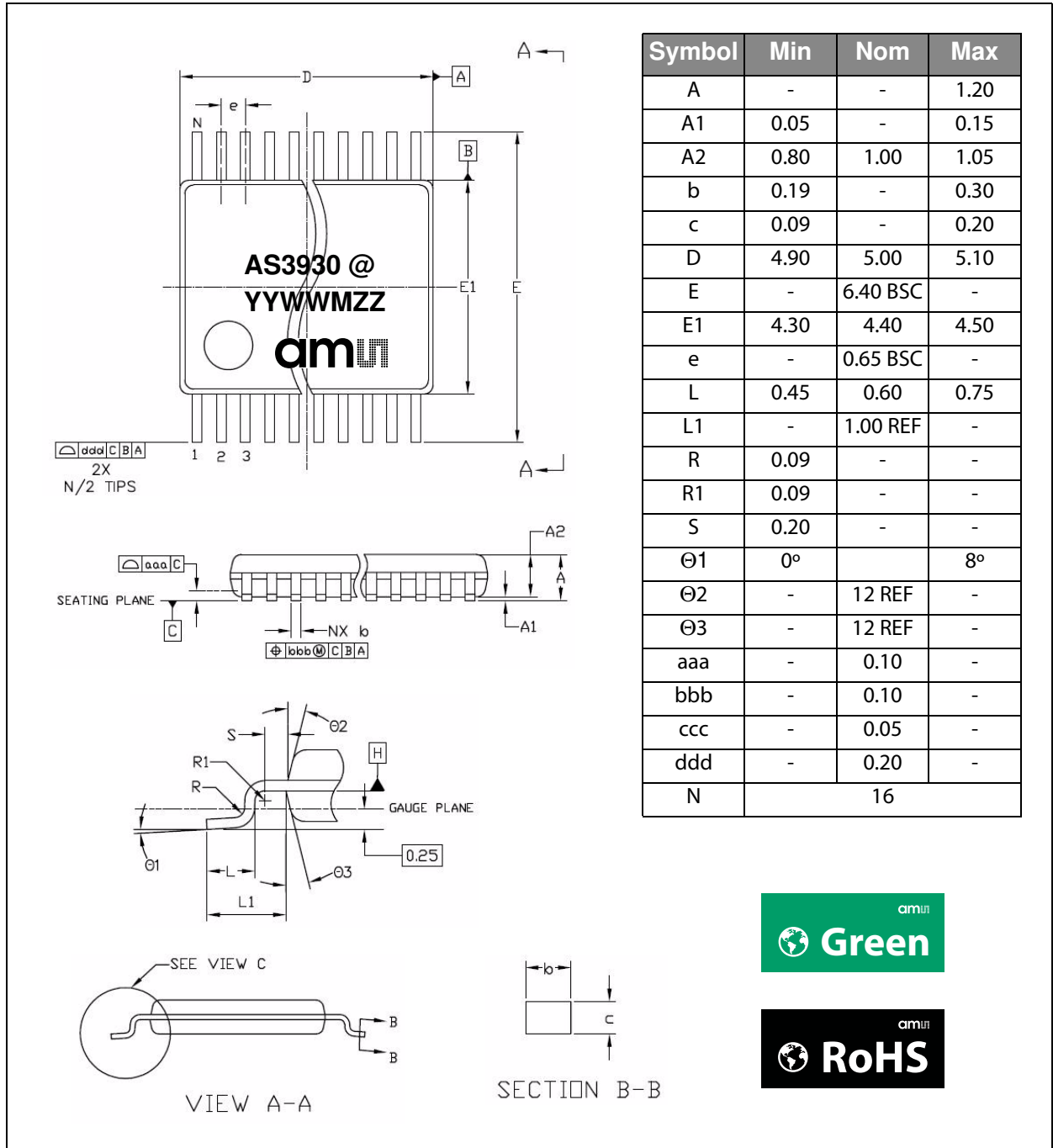

Note(s) and/or Footnote(s):

1. Dimensions and tolerancing conform to ASME Y14.5M-1994.
2. All dimensions are in millimeters. Angles are in degrees.

Figure 48:
Marking: @YYWWMZZ

@	YY	WW	M	ZZ
Sublot identifier	Year	Manufacturing Week	Assembly plant identifier	Assembly traceability code

Figure 49:
QFN 4x4 16 LD Package

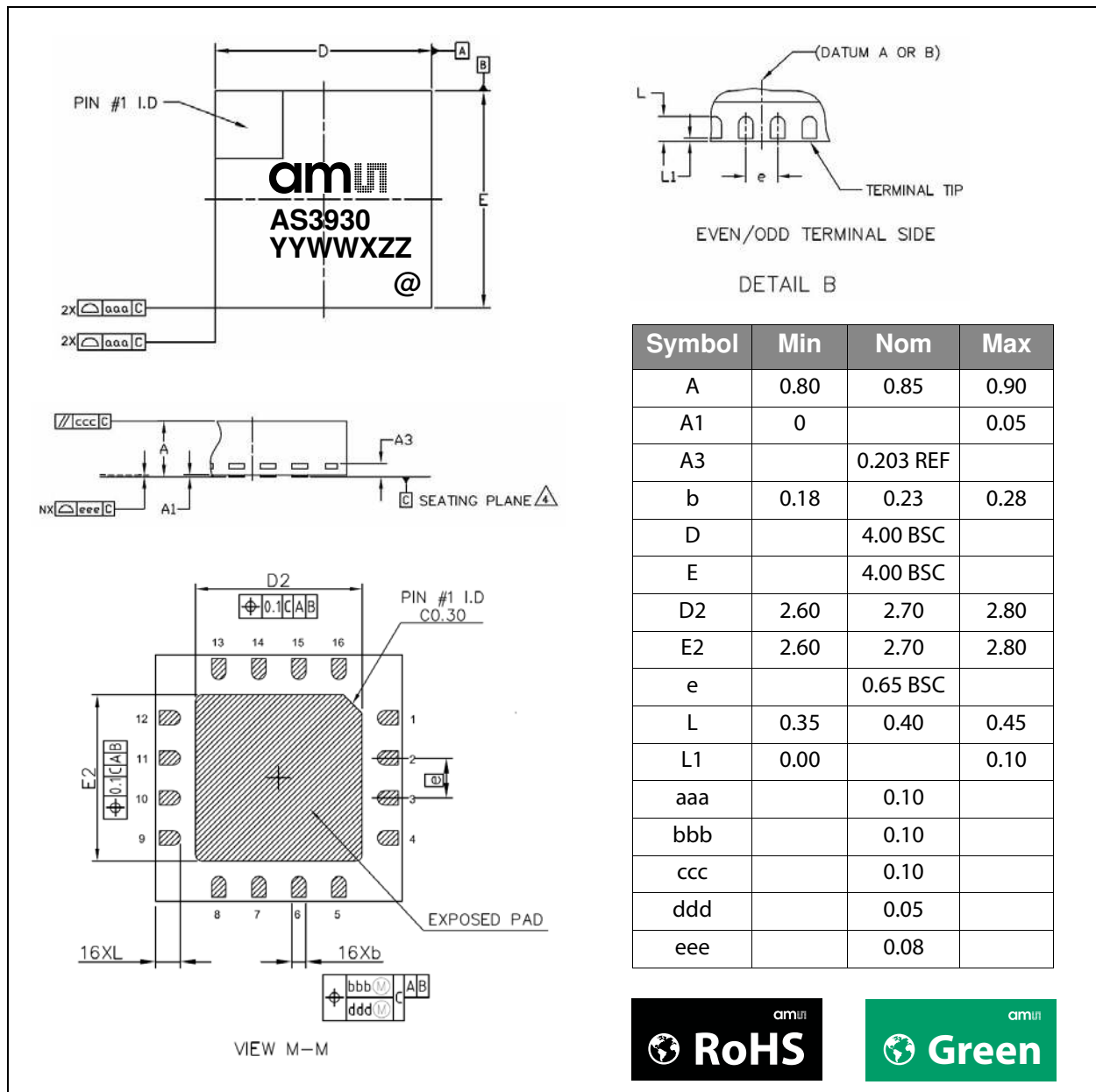

Note(s) and/or Footnote(s):

1. Dimensions and tolerancing conform to ASME Y14.5M-1994.
2. All dimensions are in millimeters. Angles are in degrees.
3. Dimension b applies to metallized terminal and is measured between 0.25mm and 0.30mm from terminal tip. Dimension L1 represents terminal full back from package edge up to 0.15mm is acceptable.
4. Coplanarity applies to the exposed heat slug as well as the terminal.
5. Radius on terminal is optional.

Figure 50:
Marking: YYWWXZZ@

YY	WW	X	ZZ	@
Year	Manufacturing Week	Assembly plant identifier	Assembly traceability code	Sublot identifier

Ordering & Contact Information

Figure 51:
Ordering Information

Ordering Code	Type	Marking	Delivery Form ⁽¹⁾	Delivery Quantity
AS3930-BTST	16-pin TSSOP	AS3930	7 inches Tape & Reel	1000 pcs
AS3930-BQFT	QFN (4×4) 16LD	AS3930	7 inches Tape & Reel	1000 pcs

Note(s) and/or Footnote(s):

1. Dry Pack: Moisture Sensitivity Level (MSL) = 3, according to IPC/JEDEC J-STD-033A.

Buy our products or get free samples online at:

www.ams.com/ICdirect

Technical Support is available at:

www.ams.com/Technical-Support

Provide feedback about this document at:

www.ams.com/Document-Feedback

For further information and requests, e-mail us at:

ams_sales@ams.com

For sales offices, distributors and representatives, please visit:

www.ams.com/contact

Headquarters

ams AG

Tobelbaderstrasse 30

8141 Unterpremstaetten

Austria, Europe

Tel: +43 (0) 3136 500 0

Website: www.ams.com

RoHS Compliant & ams Green Statement

RoHS: The term RoHS compliant means that ams AG products fully comply with current RoHS directives. Our semiconductor products do not contain any chemicals for all 6 substance categories, including the requirement that lead not exceed 0.1% by weight in homogeneous materials. Where designed to be soldered at high temperatures, RoHS compliant products are suitable for use in specified lead-free processes.

ams Green (RoHS compliant and no Sb/Br): ams Green defines that in addition to RoHS compliance, our products are free of Bromine (Br) and Antimony (Sb) based flame retardants (Br or Sb do not exceed 0.1% by weight in homogeneous material).

Important Information: The information provided in this statement represents ams AG knowledge and belief as of the date that it is provided. ams AG bases its knowledge and belief on information provided by third parties, and makes no representation or warranty as to the accuracy of such information. Efforts are underway to better integrate information from third parties. ams AG has taken and continues to take reasonable steps to provide representative and accurate information but may not have conducted destructive testing or chemical analysis on incoming materials and chemicals. ams AG and ams AG suppliers consider certain information to be proprietary, and thus CAS numbers and other limited information may not be available for release.

Copyrights & Disclaimer

Copyright ams AG, Tobelbader Strasse 30, 8141 Unterpremstaetten, Austria-Europe. Trademarks Registered. All rights reserved. The material herein may not be reproduced, adapted, merged, translated, stored, or used without the prior written consent of the copyright owner.

Devices sold by ams AG are covered by the warranty and patent indemnification provisions appearing in its General Terms of Trade. ams AG makes no warranty, express, statutory, implied, or by description regarding the information set forth herein. ams AG reserves the right to change specifications and prices at any time and without notice. Therefore, prior to designing this product into a system, it is necessary to check with ams AG for current information. This product is intended for use in commercial applications. Applications requiring extended temperature range, unusual environmental requirements, or high reliability applications, such as military, medical life-support or life-sustaining equipment are specifically not recommended without additional processing by ams AG for each application. This product is provided by ams AG "AS IS" and any express or implied warranties, including, but not limited to the implied warranties of merchantability and fitness for a particular purpose are disclaimed.

ams AG shall not be liable to recipient or any third party for any damages, including but not limited to personal injury, property damage, loss of profits, loss of use, interruption of business or indirect, special, incidental or consequential damages, of any kind, in connection with or arising out of the furnishing, performance or use of the technical data herein. No obligation or liability to recipient or any third party shall arise or flow out of ams AG rendering of technical or other services.

Document Status

Document Status	Product Status	Definition
Product Preview	Pre-Development	Information in this datasheet is based on product ideas in the planning phase of development. All specifications are design goals without any warranty and are subject to change without notice
Preliminary Datasheet	Pre-Production	Information in this datasheet is based on products in the design, validation or qualification phase of development. The performance and parameters shown in this document are preliminary without any warranty and are subject to change without notice
Datasheet	Production	Information in this datasheet is based on products in ramp-up to full production or full production which conform to specifications in accordance with the terms of ams AG standard warranty as given in the General Terms of Trade
Datasheet (discontinued)	Discontinued	Information in this datasheet is based on products which conform to specifications in accordance with the terms of ams AG standard warranty as given in the General Terms of Trade, but these products have been superseded and should not be used for new designs

Revision Information

Changes from 1.5 (2013-Feb-04) to current revision 1-62 (2014-Nov-27)	Page
Content was updated to the latest ams design	
Updated General Description & Figure 1	1
Updated Pin Assignments section	4
Added TRC (start-up time) parameter in Figure 11 and a note under it	8
Updated Figure 29	22
Updated Package Drawings & Markings section	36

Note(s) and/or Footnote(s):

1. Page and figure numbers for the previous version may differ from page and figure numbers in the current revision.
2. Correction of typographical errors is not explicitly mentioned.

Content Guide

1	General Description
1	Key Benefits & Features
2	Applications
4	Pin Assignments
4	16-pin TSSOP
5	QFN 4x4 16 LD
6	Absolute Maximum Ratings
7	Electrical Characteristics
10	Typical Operating Characteristics
12	Detailed Description
13	Operating Modes
13	Power Down Mode
13	Listening Mode
13	<i>Standard Listening Mode</i>
13	<i>ON/OFF Mode (Low Power mode)</i>
14	Preamble Detection / Pattern Correlation
14	Data Receiving
15	System and Block Specification
15	Main Logic and SDI
16	Register Table Description and Default Values
18	Serial Data Interface (SDI)
22	SDI Timing
22	Channel Amplifier and Frequency Detector
23	Frequency Detector / AGC
24	Antenna Damper
25	Demodulator / Data Slicer
26	Correlator
29	Wake-up Protocol - Carrier Frequency 125 kHz
29	Without Pattern Detection
30	Single Pattern Detection
32	False Wake-up Register
33	Real Time Clock (RTC)
33	Crystal Oscillator
34	RC-Oscillator
34	External Clock Source
36	Package Drawings & Markings
38	Ordering & Contact Information
39	RoHS Compliant & ams Green Statement
40	Copyrights & Disclaimer
41	Document Status
42	Revision Information