

Circuits from the Lab®
Reference Designs

Circuits from the Lab® reference designs are engineered and tested for quick and easy system integration to help solve today's analog, mixed-signal, and RF design challenges. For more information and/or support, visit www.analog.com/CN0303.

Devices Connected/Referenced

ADXL001	High Precision, $\pm 70\text{ g}$, $\pm 250\text{ g}$, $\pm 500\text{ g}$ Single Axis Accelerometer
AD8606	Precision, Low Noise, CMOS, Rail-to-Rail Input/Output, Dual Package Op-Amp
AD7476	2.35 V to 5.25 V, Low Power, Single-Channel, 1 MSPS, 12-Bit ADC

MEMS-Based Vibration Analyzer with Frequency Response Compensation

EVALUATION AND DESIGN SUPPORT

Circuit Evaluation Boards

- [CN-0303 Circuit Evaluation Board \(EVAL-CN0303-SDPZ\)](#)
- [Includes ADXL001 Evaluation Board \(EVAL-ADXL001-70Z\)](#)
and connecting ribbon cable
- [System Demonstration Platform \(EVAL-SDP-CB1Z\)](#)

Design and Integration Files

- [Schematics, Layout Files, Bill of Materials](#)

CIRCUIT FUNCTION AND BENEFITS

The circuit in Figure 1 offers a high linearity, low noise, wide-bandwidth vibration sensing solution. It is ideal for applications requiring a large dynamic range ($\pm 70\text{ g}$, $\pm 250\text{ g}$, or $\pm 500\text{ g}$) and a flat frequency response from dc to 22 kHz.

The circuit provides a low power solution suitable for bearing analysis, engine monitoring and shock detection.

The Analog Devices, Inc. proprietary fifth-generation *iMEMS*® process enables the ADXL001 accelerometer to provide dynamic range that extends from $\pm 70\text{ g}$ to $\pm 500\text{ g}$ in combination with 22 kHz of bandwidth.

The AD8606 is a precision, low noise, dual op amp used to create an analog bi-quad filter that flattens the output frequency response of the accelerometer.

The ADXL001 output voltage is converted into a digital word by the AD7476 low power, single-channel, 12-bit, successive approximation analog-to-digital converter (SAR ADC).

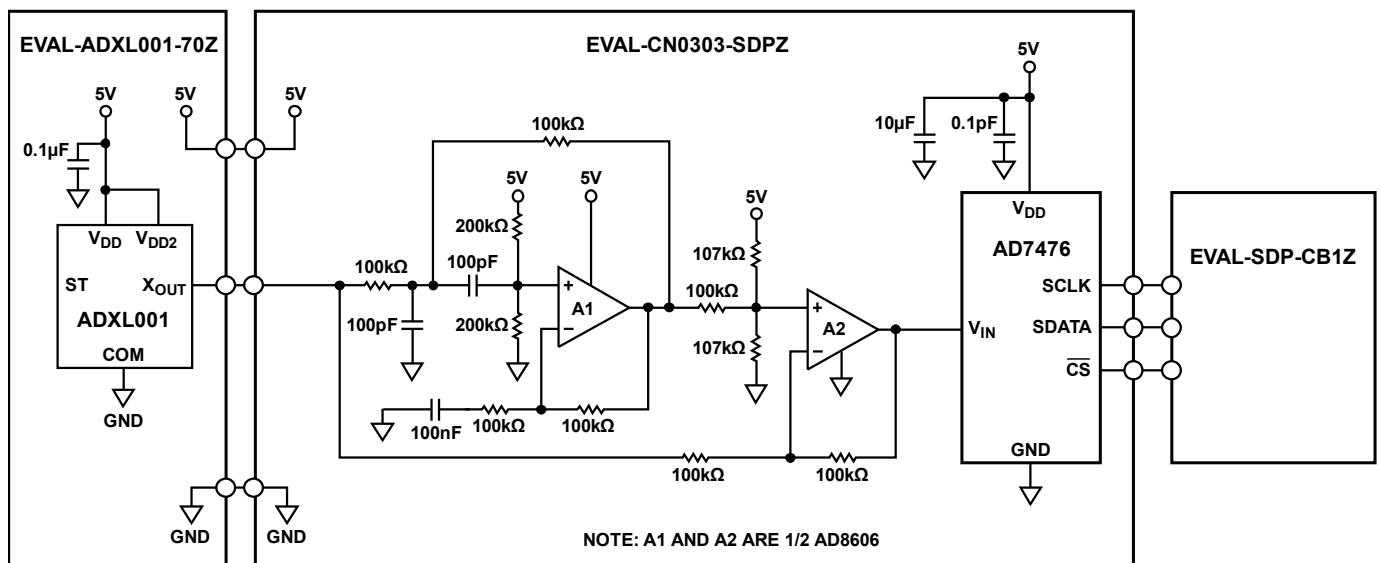

Figure 1. Single Axis Vibration Analysis System (Simplified Schematic: Decoupling and All Connections Not Shown)

Rev. A

Circuits from the Lab reference designs from Analog Devices have been designed and built by Analog Devices engineers. Standard engineering practices have been employed in the design and construction of each circuit, and their function and performance have been tested and verified in a lab environment at room temperature. However, you are solely responsible for testing the circuit and determining its suitability and applicability for your use and application. Accordingly, in no event shall Analog Devices be liable for direct, indirect, special, incidental, consequential or punitive damages due to any cause whatsoever connected to the use of any Circuits from the Lab circuits. (Continued on last page)

CIRCUIT DESCRIPTION

Accelerometer Output Characteristics

The ADXL001 is specified and tested for 3.3 V and 5 V supplies. Although operational with a supply voltage anywhere between 3 V and 6 V, optimum overall performance is achieved at 5 V.

The output voltage sensitivity is ratiometric with respect to the supply voltage. For a 3.3 V supply, the nominal output sensitivity is 16 mV/g. For a 5 V supply, the sensitivity is 24.2 mV/g.

The zero-g output level is also ratiometric and is nominally equal to $V_{DD}/2$.

The ADXL001 requires only one 0.1 μF decoupling capacitor as long as there is no noise present at the 1 MHz internal clock frequency. If necessary, larger bulk capacitors (1 μF to 10 μF) or ferrite beads can be included.

Accelerometer Physical Operation

The ADXL001 uses silicon on insulator (SOI) MEMS technology and takes advantage of mechanically coupled but electrically isolated differential sensing cells. Figure 2 is a simplified view of one of the differential sensor cell blocks. Each sensor block includes several differential capacitor unit cells. Each cell is composed of fixed plates attached to the device layer, and movable plates attached to the sensor frame. Displacement of the sensor frame changes the differential capacitance. On-chip circuitry measures the capacitance change and converts it into an output voltage.

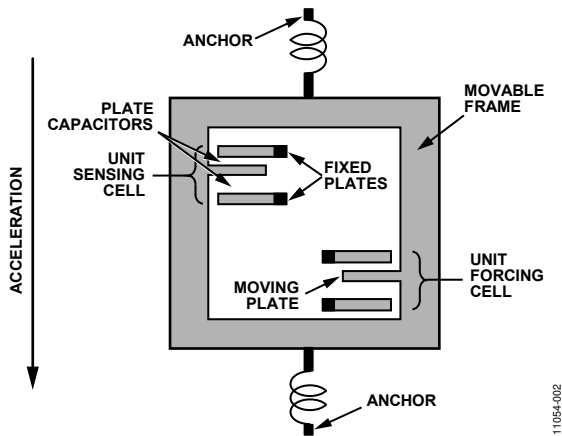

Figure 2. Simplified View of Sensor Under Acceleration

The sensor device is micro-machined in plane in the SOI device layer. Trench isolation is used to electrically isolate, but mechanically couple, the differential sensing elements. Single-crystal silicon springs suspend the structure over the handle wafer and provide resistance against acceleration forces.

The ADXL001 is an x-axis acceleration and vibration-sensing device. It produces a positive-going output voltage for vibration toward its Pin 8 marking as shown in Figure 3.

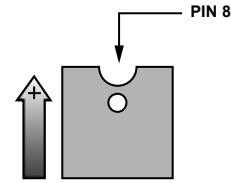

Figure 3. ADXL001 X_{OUT} Voltage Increases with Acceleration in the Positive X-Axis Direction

Interfacing to the ADC

To digitize the acceleration information, the accelerometer output voltage range must fall inside the ADC input voltage range. The AD7476 input voltage range is 0 V to V_{DD} (5 V). The ADXL001 output voltage range is 0.2 V to $V_S - 0.2$ V (4.8 V). Based on this information, any acceleration sensed by the accelerometer is digitized requiring no additional amplifiers or buffers.

Because the V_{DD} power supply of the AD7476 serves as the ADC reference, an external reference is not required. In addition, the entire circuit is ratiometric with the supply because the same V_{DD} supply also drives the ADXL001.

Frequency Response

The frequency response of the accelerometer is the most important characteristic in the system and is shown in Figure 4. As the frequency of the signal goes beyond approximately 2 kHz to 3 kHz, there is an increase in the gain of the accelerometer. At the resonant frequency of the beam (22 kHz), there is approximately 7 dB ($\times 2.24$) of peaking in the output voltage of the device. This peaking has significant ramifications for the output voltage of the accelerometer.

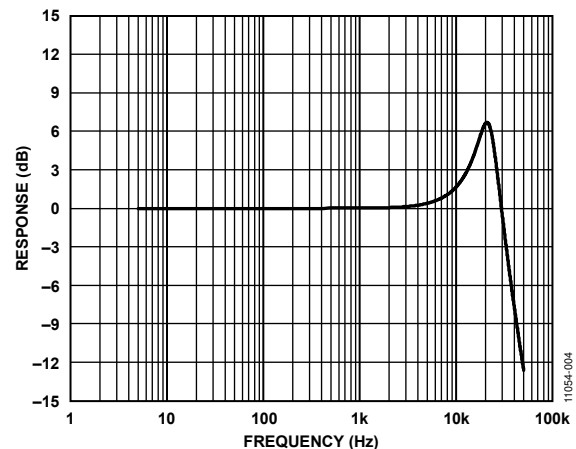

Figure 4. ADXL001 Frequency Response

Consider a 20 g acceleration at 10 kHz. The expected output voltage, assuming a zero-g output voltage of 2.5 V and a sensitivity of 24.2 mV/g is:

$$2.5 \text{ V} + (0.0242 \times 20) = 2.984 \text{ V}$$

However, this voltage is increased by approximately 2 dB of peaking, causing the actual output voltage to be:

$$2 \text{ dB} = 20 \log_{10} (V_{OUT}/2.984 \text{ V})$$

$$V_{OUT} = 3.757 \text{ V}$$

The difference between the expected output voltage and the actual output voltage is a significant source of error:

$$\text{Error} = 3.757 \text{ V} - 2.984 \text{ V} = 0.773 \text{ V}$$

It is important to correct for this error to ensure accuracy, and an analog bi-quad filter was designed specifically for this purpose. The details of its implementation are discussed in the Filter Design section.

Accelerometer Range Reduction

It is important to note that, as the frequency response of the accelerometer begins to peak, the useable acceleration range of the device decreases. Consider a 70 g acceleration at 20 kHz. The expected output voltage is:

$$2.5 \text{ V} + (24.2 \text{ mV/g} \times 70 \text{ g}) = 4.194 \text{ V}$$

Incorporating the ~7dB peaking effect:

$$7 \text{ dB} = 20 \log_{10} (V_{\text{OUT}} / 4.194 \text{ V})$$

$$V_{\text{OUT}} = 9.389 \text{ V}$$

Because the **ADXL001** has a 5 V supply rail, the output limits at approximately 0.2 V and 4.8 V. The largest measurable g-force therefore depends on the frequency of vibration.

Additional headroom of $\pm 0.5 \text{ V}$ must be allowed due to the variation in the zero-g offset voltage. The zero-g offset variation limits the maximum usable output voltage range to $\pm 1.8 \text{ V}$, corresponding to approximately $\pm 70 \text{ g}$ for vibration frequencies less than approximately 2 kHz.

As the vibration frequency increases from about 2 kHz to 22 kHz, the maximum allowable g-force before output saturation is gradually reduced by 7 dB ($\times 2.24$) to $\pm 31 \text{ g}$. As long as the maximum g-force is less than $\pm 31 \text{ g}$, the filter provides a flat frequency response to 22 kHz without saturation and loss of information.

Filter Design

To compensate for the gain peak found in the accelerometer frequency response, an analog, bi-quad, notch filter was implemented. The quality factor ($Q = 2.5$) and resonant frequency of the beam (22 kHz) are both found in the specifications table of the **ADXL001** data sheet.

By creating a notch filter with a peak of approximately -7 dB at 22 kHz, the frequency response of the accelerometer can be flattened, removing much of the difficulty in measuring vibration at higher frequencies. Figure 5 shows the frequency response for the filter, the accelerometer, and the entire signal chain. The data was taken using a sine wave input to the **EVAL-CN0303-SDPZ** board to simulate the accelerometer output.

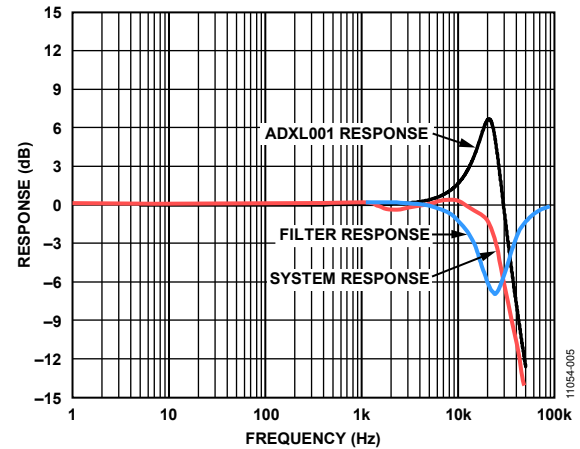

Figure 5. **ADXL001** Frequency Response, Filter Frequency Response and System Frequency Response

The notch filter was designed by modifying an example circuit found in “Passive and Active Network Analysis and Synthesis” by Aram Budak, October 1991 (ISBN-13: 978-0881336252). The transfer function for this compensator is the inverse of the previously derived transfer function. The *Multisim™ Circuit Design Suite* was used to simulate and verify the notch filter transfer function. The filter parameters were specified as $Q = 2.5$, center frequency = 22 kHz, notch depth = 7 dB.

Test Results

Two basic tests verify the performance of the system. First, a signal generator was used to drive a constant amplitude sine wave of varying frequency into the filter. Measuring the input and output voltages and plotting $20 \log_{10}(V_{\text{OUT}}/V_{\text{IN}})$ provided the frequency response of the analog filter shown in Figure 5.

Second, the frequency response of the entire signal chain was verified to ensure the performance of the design. To more accurately verify the system frequency response, a signal generator was used to simulate the **ADXL001** output.

For testing purposes, a 5 g acceleration was simulated and driven into the filter over a 50 kHz frequency range. If the **ADXL001** is subject to a sinusoidal $\pm 5 \text{ g}$ acceleration in the sensitive axis, it outputs a corresponding ac voltage:

$$\pm 5 \text{ g} \times 0.0242 \text{ V/g} = \pm 0.121 \text{ V}$$

This voltage is centered on the zero-g output, 2.5 V.

The signal generator drives this voltage into the filter. An oscilloscope was used to measure the peak output voltage of the filter. This voltage was converted back into g's (divide g's by the sensitivity) and compared to the original input acceleration. Plotting $20 \log_{10}(V_{\text{OUT}}/V_{\text{IN}})$ provides the frequency response of the system.

It is important to adjust the signal generator output voltage based on the peaking found in the frequency response of the accelerometer. For a 10 kHz frequency, the output voltage of the signal generator must be increased by approximately 1.8 dB to accurately represent the output voltage of the accelerometer experiencing a 5 g acceleration.

The results of Figure 5 show the removal of the large peak found in the frequency response of the accelerometer. The -3 dB bandwidth is approximately 23 kHz. A small amount of ripple is seen in the passband immediately prior to the roll off caused by a slight misalignment in the peak of the accelerometer frequency response and the notch in the filter response.

A Wavetek Model 81 Pulse/Function Generator was used to generate a 2 kHz sine wave and connected directly to the filter input. Figure 6 shows a screen shot of the [CN0303 Evaluation Software](#) displaying conversion data from the [AD7476](#) ADC and plotting the data in a graph. The sampling rate was 1 MSPS.

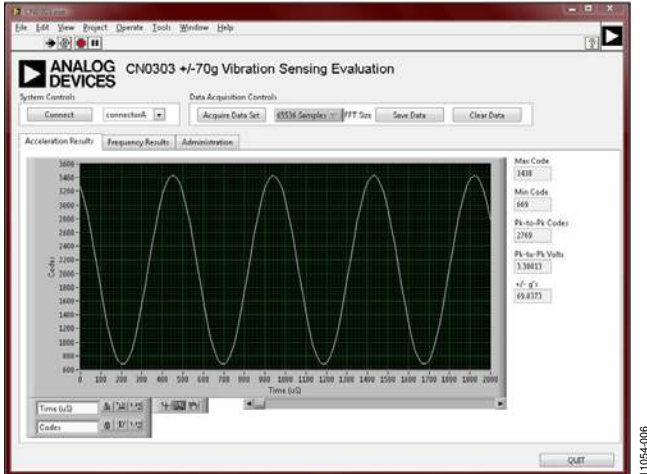

Figure 6. Screenshot of [CN0303 Evaluation Software](#) Digitizing a 2 kHz Sine Wave at a 1 MSPS Sampling Rate

PCB Layout Considerations

In any circuit where accuracy is crucial, it is important to consider the power supply and ground return layout on the board. The printed circuit board (PCB) must isolate the digital and analog sections as much as possible. The PCB for this system was constructed in a four-layer stack up with large area ground plane layers and power plane polygons. See the [MT-031 Tutorial](#) for more discussion on layout and grounding, and see the [MT-101 Tutorial](#) for information on decoupling techniques.

The [EVAL-ADXL001-70Z](#) board is connected to the [EVAL-CN0303-SDPZ](#) circuit board by a flexible ribbon cable. This allows the user to isolate the [EVAL-CN0303-SDPZ](#) from any vibrations that could cause potentially damaging mechanical stress to the circuit board, as well as allowing the user to place the [ADXL001](#) directly at the vibration source.

The power supply to the [ADXL001](#) is decoupled with a 0.1 μ F capacitor to properly suppress noise and reduce ripple. The capacitor must be placed as close to the device possible.

Power supply lines must have as large a trace width as possible to provide low impedance paths and reduce glitch effects on the supply line. Clocks and other fast switching digital signals must be shielded from other parts of the board by digital ground.

A complete design support package for this circuit note can be found at www.analog.com/CN0303-DesignSupport.



Figure 7. Photo of [EVAL-CN0303-SDPZ](#)

COMMON VARIATIONS

To produce a more complete vibration sensing solution, a two axis ([ADXL2xx](#) family) or three axis ([ADXL3xx](#) family) accelerometer can be used in place of the [ADXL001](#). By measuring acceleration in the second and third spatial dimensions, the user can write custom software allowing a more accurate and complete vibration sensing system.

CIRCUIT EVALUATION AND TEST

This circuit uses the [EVAL-SDP-CB1Z](#) system demonstration platform (SDP) board and the [EVAL-CN0303-SDPZ](#) circuit board. The two boards have 120-pin mating connectors, allowing for the quick setup and evaluation of the circuit's performance.

This circuit also uses the [EVAL-ADXL001-70Z](#) evaluation board (included with the [EVAL-CN0303-SDPZ](#) board). The output connector (P1) of this PCB must be wired to the input connector (J6) of the [EVAL-CN0303-SDPZ](#) PCB using the ribbon cable supplied.

The [EVAL-CN0303-SDPZ](#) board contains the circuit to be evaluated, as described in this circuit note. The [EVAL-SDP-CB1Z](#) evaluation board is used with the [CN0303 Evaluation Software](#) to capture the data from the [EVAL-CN0303-SDPZ](#) circuit board. The [EVAL-ADXL001-70Z](#) board contains the [ADXL001](#) IC.

Equipment Needed

The following equipment is needed:

- PC with a USB port and Windows® XP or Windows Vista® (32-bit), or Windows® 7 (32-bit)
- [EVAL-CN0303-SDPZ](#) circuit board

- [EVAL-ADXL001-70Z](#) evaluation board and ribbon cable (included with [EVAL-CN0303-SDPZ](#) board)
- [EVAL-SDP-CB1Z](#) SDP board
- [CN0303 Evaluation Software](#)
- Power supply: +6.0 V or +6.0 V wall wart
- Function generator (Wavetek 81 or equivalent) for generating simulated [ADXL001](#) output if desired

Getting Started

Load the evaluation software by placing the [CN0303 Evaluation Software](#) disc in the CD drive of the PC. Using **My Computer**, locate the drive that contains the evaluation software disc and open the **Readme** file. Follow the instructions contained in the **Readme** file for installing and using the evaluation software.

Functional Block Diagram

A functional block diagram of the test setup is shown in Figure 8. The signal generator is used to simulate the [ADXL001](#) output. The [EVAL-ADXL001-70Z](#) board can be connected to [EVAL-CN0303-SDPZ](#) board for actual vibration measurements by using the ribbon cable to connect the 5-pin header (P1) of the [EVAL-ADXL001-70Z](#) to the 5-pin header (J6) of the [EVAL-CN0303-SDPZ](#).

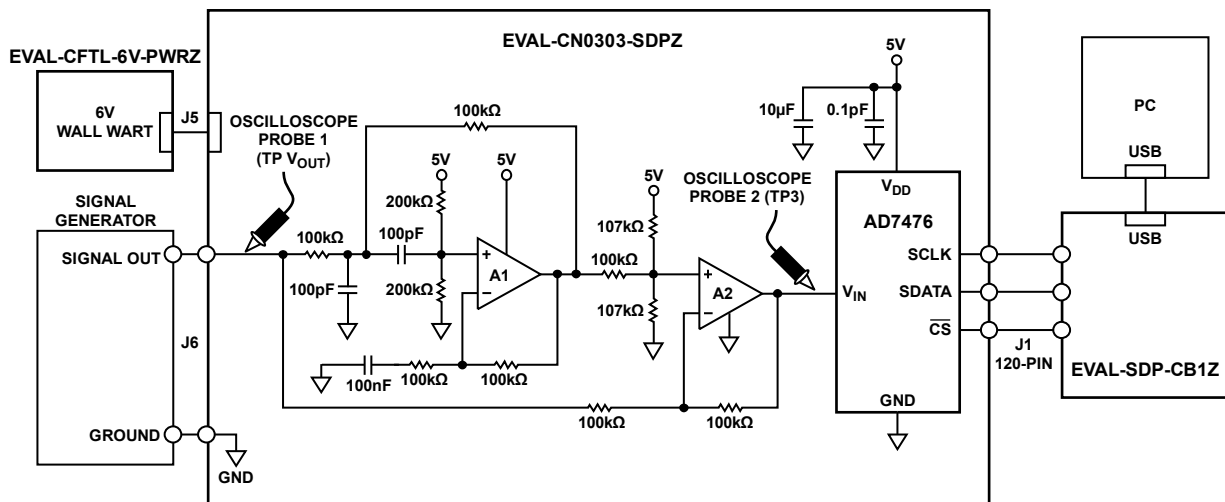

Figure 8. Test Setup Functional Block Diagram

11054-008

Setup

Connect the 120-pin connector (J1) on the [EVAL-CN0303-SDPZ](#) circuit board to the connector on the [EVAL-SDP-CB1Z](#) SDP board. Use nylon hardware to firmly secure the two boards, using the holes provided at the ends of the 120-pin connectors.

Connect the 5-pin header (P1) of the [EVAL-ADXL001-70Z](#) evaluation board to the 5-pin header (J6) of the [EVAL-CN0303-SDPZ](#) circuit board using the ribbon cable.

Connect a +6.0 V power supply to connector J5 of the [EVAL-CN0303-SDPZ](#) board. Connect the USB cable supplied with the SDP board to the USB port on the PC. Do not connect the USB cable to the mini USB connector on the SDP board at this time.

Test

Launch the evaluation software, and connect the USB cable from the PC to the USB mini-connector on the SDP board.

After USB communications are established, the SDP board can now be used to send, receive, and capture serial data from the [EVAL-CN0303-SDPZ](#) board.

Information regarding the SDP board can be found in the [SDP User Guide](#).

Information and details regarding test setup and calibration, and how to use the evaluation software for data capture can be found in the software [Readme](#) file found at www.analog.com/CN0303-UserGuide.

LEARN MORE

CN-0303 Design Support Package:

<http://www.analog.com/CN0303-DesignSupport>

MT-031 Tutorial, *Grounding Data Converters and Solving the Mystery of "AGND" and "DGND"*, Analog Devices.

MT-101 Tutorial, *Decoupling Techniques*, Analog Devices.

AN-688 Application Note, *Phase and Frequency Response of iMEMS Accelerometers and Gyros*, Analog Devices

Linear Circuit Design Handbook, Hank Zumbahlen, Analog Devices

Aram Budak, *Passive and Active Network Analysis and Synthesis*, October 1991, ISBN-13: 978-0881336252.

Data Sheets and Evaluation Boards

[CN-0303 Circuit Evaluation Board \(EVAL-CN0303-SDPZ\)](#)

[System Demonstration Platform \(EVAL-SDP-CB1Z\)](#)

[ADXL001 Data Sheet](#)

[ADXL001 Evaluation Board \(EVAL-ADXL001-70Z\)](#)

[AD8606 Data Sheet](#)

[AD7476 Data Sheet](#)

[AD7476 Evaluation Board](#)

REVISION HISTORY

9/2016—Rev. 0 to Rev. A

Changed EVAL-SDP-CS1Z to EVAL-SDP-CB1Z..... Throughout

7/2013—Revision 0: Initial Version

(Continued from first page) Circuits from the Lab reference designs are intended only for use with Analog Devices products and are the intellectual property of Analog Devices or its licensors. While you may use the Circuits from the Lab reference designs in the design of your product, no other license is granted by implication or otherwise under any patents or other intellectual property by application or use of the Circuits from the Lab reference designs. Information furnished by Analog Devices is believed to be accurate and reliable. However, Circuits from the Lab reference designs are supplied "as is" and without warranties of any kind, express, implied, or statutory including, but not limited to, any implied warranty of merchantability, noninfringement or fitness for a particular purpose and no responsibility is assumed by Analog Devices for their use, nor for any infringements of patents or other rights of third parties that may result from their use. Analog Devices reserves the right to change any Circuits from the Lab reference designs at any time without notice but is under no obligation to do so.