

3.5V to 60V Input 1ch Boost DC/DC Controller

BD9615MUV-LB

General Description

This is the product guarantees long time support in Industrial market.

BD9615MUV-LB is a low side MOSFET controller with high withstand voltage (60V). It is suitable for circuits requiring low side FET such as boost and flyback, and it can be used in various applications.

An external resistor can adjust the switching frequency from 100kHz to 2500kHz. It reduces the total mounting area because It can operate at extremely high switching frequency. In addition, it has an external clock synchronization function to perform noise management. BD9615MUV-LB has Thermal Shutdown (TSD), Over Voltage Protection (OVP), and Over Current Protection (OCP) to prevent damage caused by various abnormal modes.

Features

- Long Time Support Product for Industrial Applications
- Wide Input Voltage Range: 3.5V to 60V
- Frequency Setting Function: 100kHz to 2500kHz
- External Clock Synchronization Function
- Soft Start Time Control Function
- ON/OFF Control by the EN Pin (Standby Current 0μA)
- Over Voltage Protection Function by an Independent Pin
- Normal/Abnormal Signal Output by the PGDB Pin
- UVLO Control Function by External Resistors
- MAX DUTY Change Function: (50%/90%)
- High Power Small Package (VQFN16KV3030)

Applications

- Industrial Instruments

Typical Application Circuit

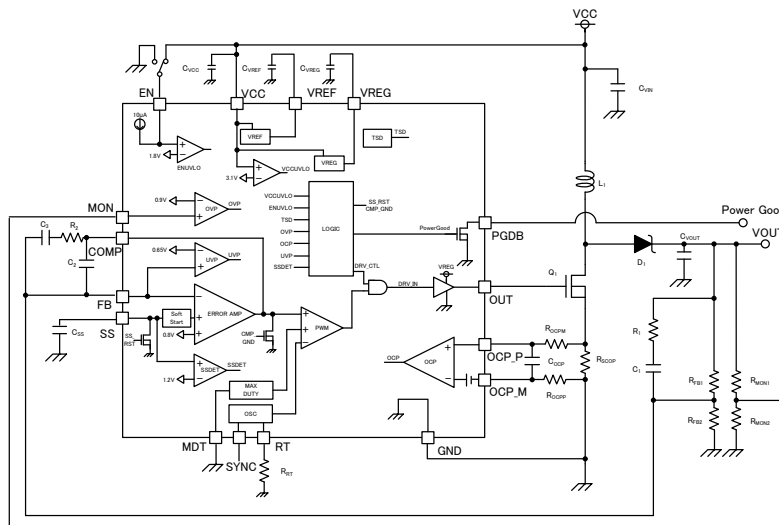

Figure 1. Typical Application Circuit

Key Specifications

- Input Voltage Range: 3.5V to 60V
- Reference Voltage Precision: (Ta=25°C) 0.8V±1.5%
(Ta=-40°C to +105°C) ±2.0%
- Frequency Range: 100kHz to 2500kHz
- Operating Temperature Range: -40°C to +105°C

Package

VQFN16KV3030

W (Typ) x D (Typ) x H (Max)

3.00mm x 3.00mm x 1.00mm

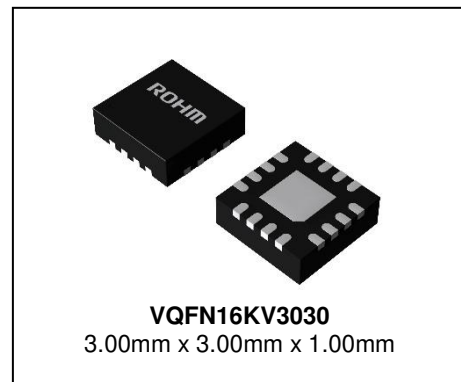

Pin Configuration

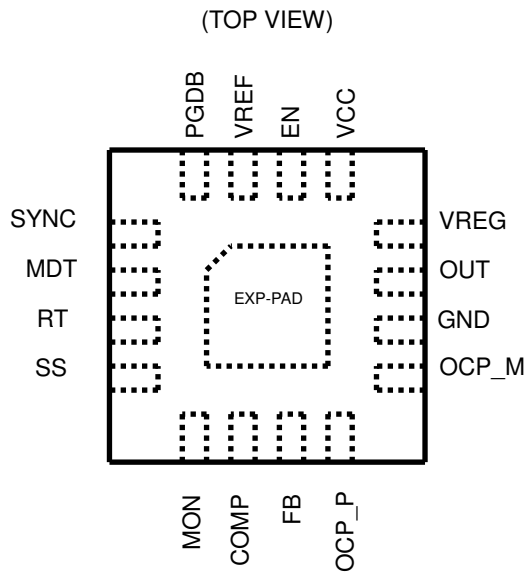

Figure 2. Pin Configuration

Pin Description

Pin No.	Pin Name	Function
1	SYNC	External clock input pin
2	MDT	MAX DUTY setting input pin
3	RT	Resistor pin for setting frequency
4	SS	Pin for setting soft start time
5	MON	Output voltage monitor input Pin
6	COMP	ERROR AMP output pin
7	FB	ERROR AMP input pin
8	OCP_P	Over current detect pin plus input pin
9	OCP_M	Over current detect pin minus input pin. Connect to GND
10	GND	GND pin
11	OUT	Output pin for external FET driver
12	VREG	Power voltage output pin for driver
13	VCC	Power input pin
14	EN	ON/OFF control pin
15	VREF	Internal power voltage output pin
16	PGDB	Power Good output pin
-	EXP-PAD	Thermal pad for heat dissipation. Connect to GND for increased heat dissipation.

Block Diagram

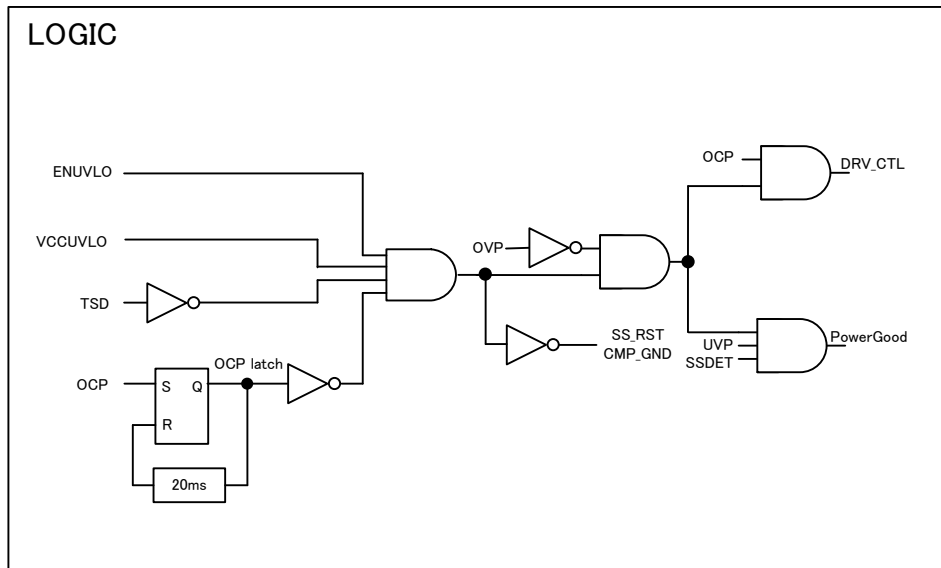
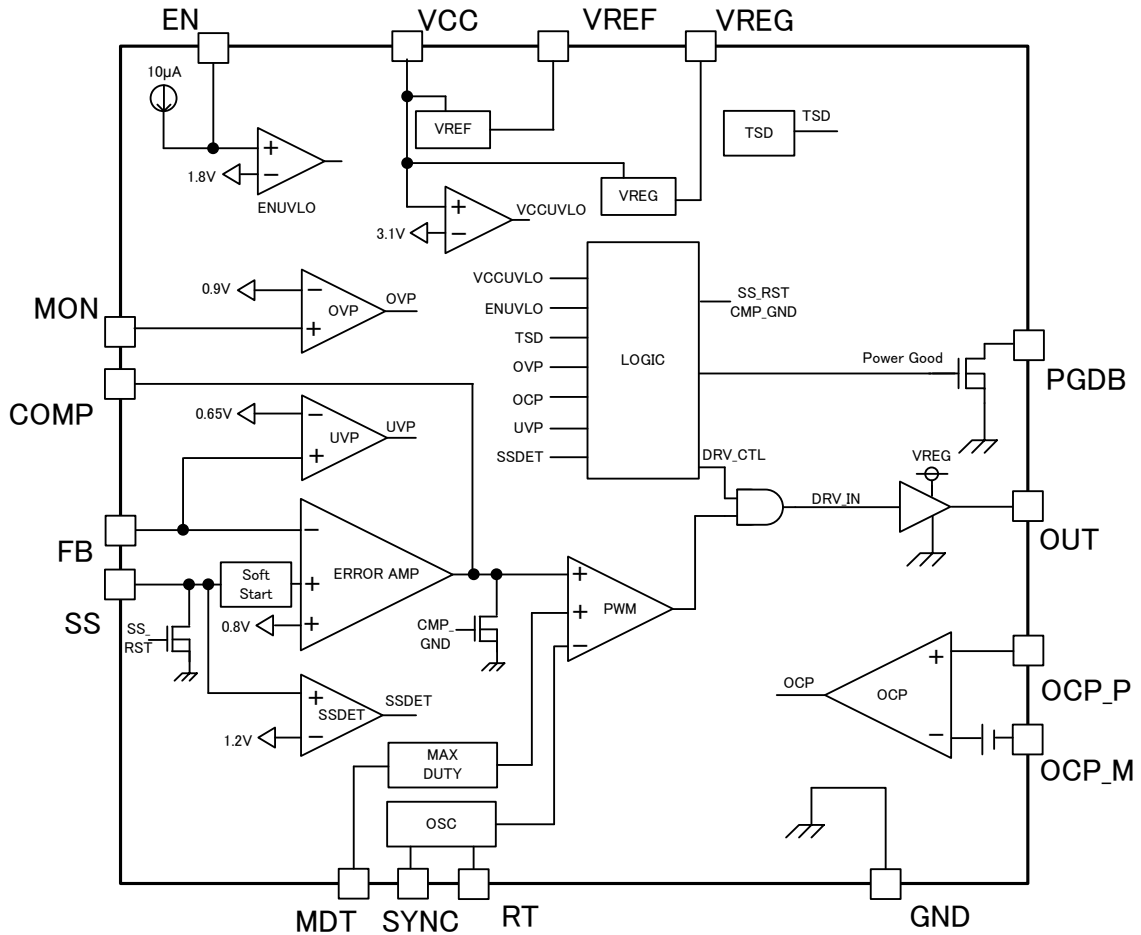

Figure 3. Block Diagram

Description of Blocks

1. **ERROR AMP**
The ERROR AMP block is an error amplifier that detects the output signal and outputs the PWM control signal. The internal reference voltage is set to 0.8V (Typ). Connect a phase compensation element at the COMP pin.
2. **OSC**
OSC block is an oscillation circuit with frequency setting function and external synchronization function. The oscillation frequency can be set by the RT pin. It can do external clock synchronous operation by inputting an external clock at the SYNC pin that is within $\pm 20\%$ of the set frequency. When not using the external synchronization function, connect the SYNC pin to GND.
3. **MAX DUTY**
It is a MAX DUTY switching function. It can switch MAX DUTY 50% and 90% by setting H/L voltage. (H: 50%, L: 90%)
4. **PWM**
PWM is a voltage – pulse width converter for controlling output voltage depending on the input voltage. It compares the internal sawtooth waveform with the ERROR AMP output voltage, controls the pulse and outputs it to the driver.
5. **VREF**
The VREF block is an internal circuit power supply regulator. This voltage is 3.0V (Typ).
6. **VREG**
VREG block is regulator for FET drive voltage. This voltage is 5.0V (Typ). Voltage can be applied from an output voltage to the VREG pin.
7. **VCCUVLO**
The VCCUVLO block prevents internal circuit error during decrease of power supply voltage. It monitors the VCC pin voltage. When the VCC voltage becomes 3.1V (Typ) or less, it turns off output FET and DC/DC converter output, and resets Soft Start circuit.
8. **ENUVLO**
It can set low input voltage protection setting by configuring the EN pin with a resistor divider from VCC. If the voltage from this pin is 0.3V or less, IC operation is off. If it is between 1.4V and 1.7V, internal REG circuit turns on. If it is 1.8V (Typ) or more, the IC operates and a hysteresis generation current of 10 μ A (Typ) is sourced from the internal circuit. To turn off the IC, source current should be removed.
9. **TSD**
The TSD block is for thermal protection. When it detects the temperature exceeding Maximum Junction Temperature ($T_j=150^\circ\text{C}$), it turns off the output FET, and resets Soft Start circuit. When the temperature is decreased, the IC automatically returns to normal operation with hysteresis.
10. **OCF**
This IC has over current protection to protect the FET from over current. If over current flows in FET, OCF function turns off the output and protects FET.
11. **OVP**
The OVP block is an over voltage output detect function. If the MON pin voltage is 0.9V (Typ) or more, IC operation is OFF. OVP detect threshold has a hysteresis of 50mV (Typ).
12. **UVP**
The UVP block is an under voltage output detect function. If the FB pin voltage is 0.65V (Typ) or less, the comparator output is low. The output signal is added with other protection feature detection signals, and is output from the PGDB pin.
13. **Soft Start**
The Soft Start circuit raises slowly the output voltage of the DC/DC converter to prevent in-rush current during start-up. Soft Start time can be adjusted by an external capacitor C_{SS} .
14. **SSDET**
This is a Soft Start finish detect block. If the SS pin voltage is SS_{DETTH} (1.2V (Typ)) or more, SSDET output is high. Output signal is added with other protection feature detection signals, and is output from the PGDB pin.
15. **Power Good**
This block generates an output signal that is the output voltage state of Normal or Error.

Absolute Maximum Ratings (Ta=25°C)

Parameter	Symbol	Rating	Unit
Supply Voltage VCC to GND EN to GND PGDB to GND	VCC VEN VPGDB	62	V
Supply Voltage VREG to GND OUT to GND	VREG	12	V
Supply Voltage VREF, SS, FB, COMP, MDT, RT, SYNC, OCP_P, OCP_M, MON to GND	VREF, VSS, VFB, VCOMP, VMDT, VRT, VSYNC, VOCP_P, VOCP_M, VMON	7	V
Storage Temperature Range	Tstg	-55 to +150	°C
Maximum Junction Temperature	Tjmax	150	°C

Caution 1: Operating the IC over the absolute maximum ratings may damage the IC. The damage can either be a short circuit between pins or an open circuit between pins and the internal circuitry. Therefore, it is important to consider circuit protection measures, such as adding a fuse, in case the IC is operated over the absolute maximum ratings.

Caution 2: Should by any chance the maximum junction temperature rating be exceeded the rise in temperature of the chip may result in deterioration of the properties of the chip. Increase the board size and copper area to prevent exceeding the maximum junction temperature rating.

Thermal Resistance^(Note 1)

Parameter	Symbol	Thermal Resistance (Typ)		Unit
		1s ^(Note 3)	2s2p ^(Note 4)	
VQFN16KV3030				
Junction to Ambient	θ_{JA}	189.0	57.5	°C/W
Junction to Top Characterization Parameter ^(Note 2)	Ψ_{JT}	23	10	°C/W

(Note 1) Based on JESD51-2A(Still-Air).

(Note 2) The thermal characterization parameter to report the difference between junction temperature and the temperature at the top center of the outside surface of the component package.

(Note 3) Using a PCB board based on JESD51-3.

Layer Number of Measurement Board	Material	Board Size
Single	FR-4	114.3mm x 76.2mm x 1.57mm
Top		
Copper Pattern	Thickness	
Footprints and Traces	70 μ m	

(Note 4) Using a PCB board based on JESD51-5, 7.

Layer Number of Measurement Board	Material	Board Size	Thermal Via ^(Note 5)		
			Pitch	Diameter	
4 Layers	FR-4	114.3mm x 76.2mm x 1.6mm	1.20mm	Φ 0.30mm	
Top		2 Internal Layers		Bottom	
Copper Pattern	Thickness	Copper Pattern	Thickness	Copper Pattern	Thickness
Footprints and Traces	70 μ m	74.2mm x 74.2mm	35 μ m	74.2mm x 74.2mm	70 μ m

(Note 5) This thermal via connects with the copper pattern of all layers.

Recommended Operating Conditions

Parameter	Symbol	Min	Typ	Max	Unit
Power Supply Voltage	VCC	3.5	12	60	V
Switching Frequency	f _{OSC}	100	500	2500	kHz
Switching Frequency Setting Resistor	R _{RT}	19	100	500	k Ω
External Synchronize Frequency	f _{EXT}	100	-	2500	kHz
External Synchronize Frequency for RT Setting Frequency	-	-20	-	+20	%
Operating Temperature	Topr	-40	+25	+105	°C

Electrical Characteristics (Unless otherwise specified Ta=25°C, VCC=12V, VEN=3V, RRT=100kΩ)

Parameter	Symbol	Limit			Unit	Conditions	
		Min	Typ	Max			
Circuit Current							
Standby Current	I _{ST}	-	0	10	μA	V _{EN} =0V	
Operating Current	I _{CC}	-	2.0	4.0	mA	V _{FB} =1.2V	
VCCUVLO							
UVLO Detect Threshold Voltage	V _{UV}	2.9	3.1	3.3	V	VCC sweep down	
UVLO Hysteresis	V _{UVHYS}	30	100	200	mV		
VREF							
Output Voltage	V _{REF}	-	3.0	-	V		
VREG							
Output Voltage	V _{REG}	4.8	5.0	5.2	V		
OVLO Threshold Voltage	V _{REGOV}	5.2	5.4	5.6	V	V _{REG} sweep up	
OVLO Hysteresis	V _{REGOVHYS}	30	100	200	mV		
Oscillator							
Oscillating Frequency	f _{OSC}	450	500	550	kHz	R _{RT} =100kΩ	
MAX DUTY Cycle	MAX DUTY1	D _{MAX1}	82	90	98	%	V _{MDT} =L, V _{SYNC} =0V
	MAX DUTY2	D _{MAX2}	42	50	58	%	V _{MDT} =H, V _{SYNC} =0V
MDT Pin Input High Level	V _{IH_MD}	0.8 x V _{REF}	-	V _{REF} + 0.2	V		
MDT Pin Input Low Level	V _{IL_MD}	-0.3	-	0.2 x V _{REF}	V		
MDT Pin Input Current	I _{IH_MD}	-	3	8	μA	V _{MDT} =3.0V	
ERROR AMP							
FB Threshold Voltage	V _{FB}	0.788	0.800	0.812	V	Ta=25°C	
		0.784	0.800	0.816	V	Ta=-40°C to +105°C	
FB Pin Input Current 1	I _{FB1}	-1	0	+1	μA	V _{FB} =0V	
FB Pin Input Current 2	I _{FB2}	-1	0	+1	μA	V _{FB} =3.0V	
Maximum Output Voltage	V _{CM_{PH}}	2.7	V _{REF}	-	V		
Minimum Output Voltage	V _{CM_{PL}}	-	0	0.3	V		
Output Sink Current	I _{CM_{PSI}}	0.5	1.5	-	mA	V _{COMP} =1.25V, V _{FB} =1.5V	
Output Source Current	I _{CM_{PSO}}	100	180	-	μA	V _{COMP} =1.25V, V _{FB} =0V	
Soft Start							
SS Pin Source Current	I _{SSSO}	1.4	2	2.6	μA	V _{SS} =0.5V	
SS Pin Sink Current	I _{SSSI}	5	12	-	mA	V _{SS} =0.5V	
Power Good Signal Output							
PGDB Pin Output Low Level Voltage	V _{PGDBOL}	-	-	0.4	V	I _{PGDB} =1mA	
PGDB Pin Leak Current	I _{PGDBLK}	-	0	10	μA	V _{PGDB} =60V	
Monitor Output Voltage							
UVP Detect Threshold Voltage	V _{PGTH}	0.60	0.65	0.70	V	V _{FB} sweep down	
UVP Detect Hysteresis	V _{PGHYS}	-	50	75	mV		
OVP Detect Threshold Voltage	V _{OVPTH}	0.85	0.90	0.95	V	V _{MON} sweep up	
OVP Detect Hysteresis	V _{OVPHYS}	-	50	75	mV		
MON Pin Input Current 1	I _{MON1}	-1	0	+1	μA	V _{MON} =0.0V	
MON Pin Input Current 2	I _{MON2}	-1	0	+1	μA	V _{MON} =3.0V	
Output							
Output High Side ON Resistance	R _{ONH}	1.5	3.0	4.5	Ω	V _{REG} =5.0V	
Output Low Side ON Resistance	R _{ONL}	0.8	1.7	2.6	Ω	V _{REG} =5.0V	

Electrical Characteristics (Unless otherwise specified Ta=25°C, VCC=12V, VEN=3V, RRT=100kΩ) - continued

Parameter	Symbol	Limit			Unit	Conditions
		Min	Typ	Max		
OCP						
Over Current Detect Threshold	V _{OCP} TH	80	100	120	mV	
OCP_P Pin Input Bias Current	I _{OCP_P}	-	20	100	μA	V _{OCP_P} =0.1V
OCP_M Pin Input Bias Current	I _{OCP_M}	-	50	100	μA	V _{OCP_M} =GND
Over Current Detect Latch Stop Time	t _{OCP}	10	20	30	ms	
CTL						
EN Pin Internal REG ON-Threshold	V _{ENON}	0.3	-	1.4	V	
EN Pin UVLO Threshold	V _{ENUV}	1.7	1.8	1.9	V	IC Output ON condition
EN Pin Source Current	I _{EN}	9.0	10.0	11.0	μA	V _{EN} =3V
SYNC						
SYNC Pin Threshold Voltage High	V _{SYNCH}	2.0	-	5.5	V	
SYNC Pin Threshold Voltage Low	V _{SYNCL}	-0.3	-	+0.8	V	
SYNC Pin Input Current	I _{SYNC}	6	12	24	μA	V _{SYNC} =3V

Detailed Description

● **Frequency Setting Function**

It can determine frequency input to PWM by using the RT pin. It establishes constant current in the IC by connecting a timing resistor, R_{RT}. Oscillation frequency can be set from 100kHz to 2500kHz and calculated as follows.

$$f_{osc} = \frac{1}{20 \times 10^{-9} + R_{RT} / (50 \times 10^9)} \text{ [Hz]}$$

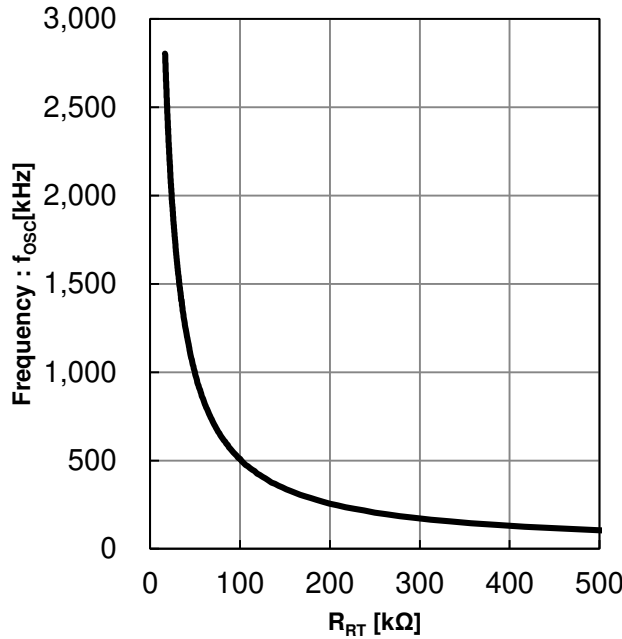

Figure 4. Frequency vs R_{RT}

● **External CLK for SYNC Function**

This IC can operate synchronization function by inputting an external CLK signal to the SYNC pin. Input CLK signal is limited within ±20% of the frequency set by the RT pin. LOW level is 0.8V or less, and HIGH level is 2.0V or more. Required width of H section and L section is 100ns or more. After the 3rd input pulse at the SYNC pin, falling edge of internal sawtooth wave synchronizes with the falling edge of the SYNC pin. If external CLK stops, the device transitions to self-running mode after 1.5 times of oscillation period.

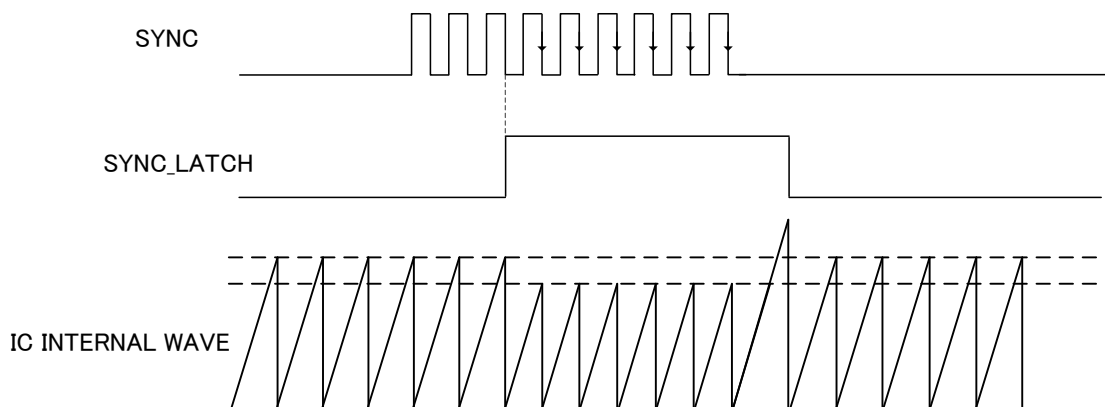

Figure 5. Frequency Synchronization Function Timing Chart

Detailed Description - continued

● In the Case of Not Using the Synchronization Function

Although the SYNC pin is internally pulled down by a resistor, it is recommended to connect the SYNC pin to GND if the synchronization function is not in use.

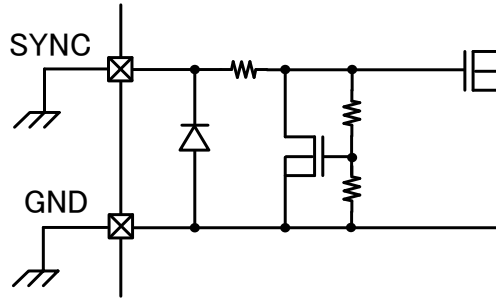

Figure 6. Circuit Diagram of SYNC Pin Not in Use

● MDT Pin Function

It can change MAX DUTY by processing the MDT pin

If the MDT pin is connected to the GND pin, MAX DUTY is prescribed in D_{MAX1} and is limited to 90% (Typ).

If the MDT pin is connected to the VREF pin, MAX DUTY is prescribed in D_{MAX2} and is limited to 50% (Typ).

To prevent malfunction caused by noise, connect the MDT pin to the GND pin or the VREF pin.

When External Synchronize Frequency is input from SYNC (f_{EXT}), MAX DUTY is determined by the frequency (f_{OSC}) set by the RT pin and MAX DUTY set by the MDT pin and is prescribed in D_{MAX_SYNC} by following formula.

$$D_{MAX_SYNC} = \left(1 - \frac{\frac{1}{f_{OSC}} \times (1 - D_{MAX})}{\frac{1}{f_{EXT}}} \right) \times 100 \text{ [%]}$$

Where:

MDT=GND: $D_{MAX} = D_{MAX1}$: 90% (Typ)

MDT=VREF: $D_{MAX} = D_{MAX2}$: 50% (Typ)

● UVLO Control Function by External Resistors

The EN pin has built-in precise reset function. The EN pin connected with a resistor divider from VCC, as shown in Figure 7, can set low voltage malfunction prevention more than internal UVLO.

When it is used, establish R_{EN1} and R_{EN2} , as shown in Figure 7, for any VCC start-up voltage V_{START} [V] and VCC shutdown voltage V_{STOP} [V].

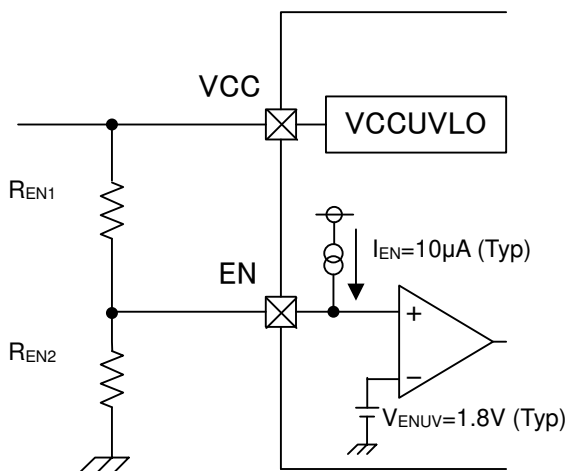

$$R_{EN1} = \frac{V_{START} - V_{STOP}}{I_{EN}} \text{ [\Omega]}$$

$$R_{EN2} = \frac{V_{ENUV} \times R_{EN1}}{V_{START} - V_{ENUV}} \text{ [\Omega]}$$

Figure 7. Circuit Diagram of UVLO External Setting Method

Detailed Description - continued

● Soft Start Time

Soft Start Time t_{SS} is determined by Soft Start Time Setting Capacitor C_{SS} , SS Source Current I_{SSSO} , and the FB pin Threshold Voltage V_{FB} . Set C_{SS} capacitance that can be fully discharged during the “Hiccup” time when OCP is detected.

$$t_{SS} = C_{SS} \times \frac{V_{FB}}{I_{SSSO}} \text{ [s]}$$

In addition, when COMP terminal capacitor C_3 is big and C_{SS} is small, rise voltage ΔV_{SS} of the SS pin voltage becomes big at time t_{COMP} before COMP pin voltage arriving at lower voltage of the internal saw-tooth wave (1.0V) from EN ON, and rush current occurs at the time of switching start. t_{COMP} , ΔV_{SS} is calculated in the following formula. Set C_{SS} and C_{OUT} in consideration of rush current to be proportional to ΔV_{SS} and C_{OUT} .

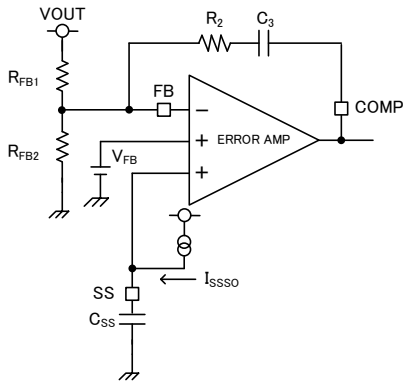

Figure 8. Error amplifier circuit diagram

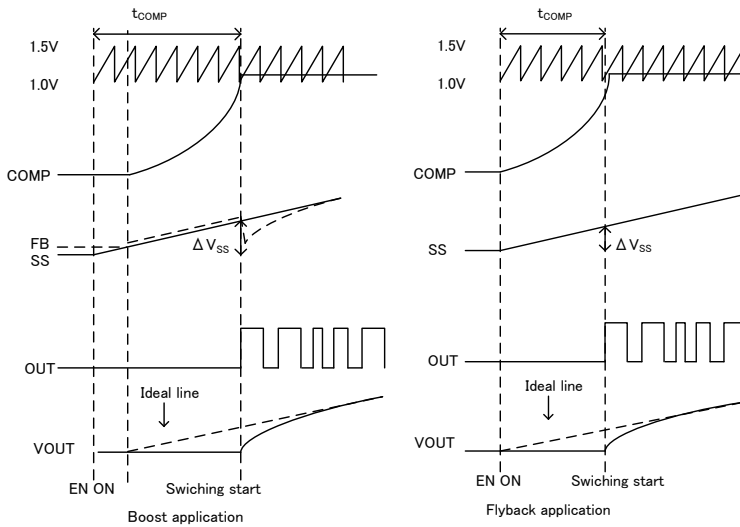

Figure 9. Output voltage starting diagram

Boost application

$$t_{COMP} = C_3 \left(\sqrt{(R_{FB2} + R_2)^2 + \frac{2 \times C_{SS} \times R_{FB2}}{C_3 \times I_{SS}} \left(\frac{R_2 \times V_{CC}}{R_{FB1} + R_{FB2}} + 1 \right)} - (R_{FB2} + R_2) \right) + \frac{C_{SS} \times V_{CC} \times R_{FB2}}{I_{SS} \times (R_{FB1} + R_{FB2})} \text{ [s]}$$

Flyback application

$$t_{COMP} = C_3 \left(\sqrt{(R_{FB1} // R_{FB1} + R_2)^2 + \frac{2 \times C_{SS} \times R_{FB1} // R_{FB1}}{C_3 \times I_{SS}}} - (R_{FB1} // R_{FB1} + R_2) \right) \text{ [s]}$$

$$\Delta V_{SS} = \frac{I_{SS}}{C_{SS}} \times t_{COMP} \text{ [V]}$$

Detailed Description - continued

● **OVP Function**

The MON pin has built-in OVP function. When the MON pin voltage becomes V_{OVPTH} or more, switching of the OUT pin is stop and switching is reopened if the MON pin voltage becomes $V_{OVPTH}-V_{OVPHYS}$ or less. The OVP detect voltage (V_{OVP}) can be set by connecting the MON pin with a resistor divider from V_{OUT} , as shown in Figure 10.

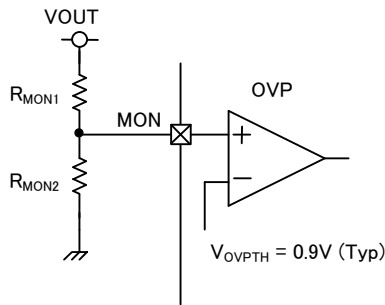

$$V_{OVP} = \frac{R_{MON1} + R_{MON2}}{R_{MON2}} \times V_{OVPTH} \text{ [V]}$$

Figure 10. Circuit Diagram of OVP Function Setting Method

● **OCP Function**

If over current flows in FET, OCP function turns off the output and protects FET. The voltage between the OCP_P pin and the OCP_M pin is monitored by OCP sense resistance. If the voltage exceeds the overcurrent detection voltage (100mV (Typ)), the OUT pin is set to Low during the period (pulse by pulse control). When OCP is detected twice consecutively, the IC is turned off 20ms (Typ) (“hiccup” operation), and the IC is turned on if the voltage between the OCP_P pin and the OCP_M pin is lower than the over current detect voltage.

$$R_{SOCP} = \frac{V_{OCPH}}{I_{OCP}} \text{ [\Omega]}$$

Where:

V_{OCPH} Over Current Detect Threshold (100mV (Typ))
 I_{OCP} OCP detect current

If OCP detect circuit is unused, short the OCP_P pin and the OCP_M pin to the GND pin near the IC.

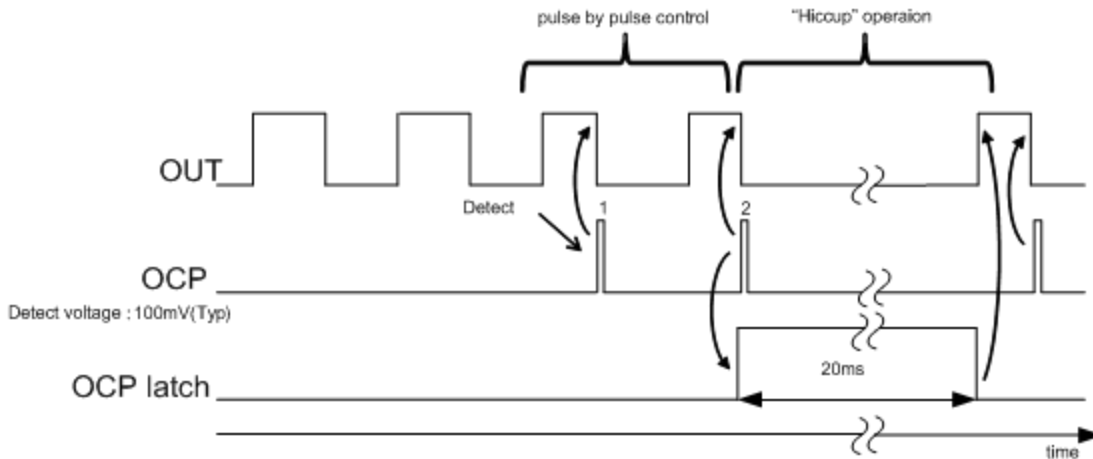

Figure 11. Timing Chart at OCP Operation

Detailed Description – continued

[Noise Design for the OCP_P pin and the OCP_M pin]

The OCP input OCP_P OCP_M is a very sensitive circuit.

Therefore, there is a possibility of erroneous detection due to generated noise on the board.

As a measure to prevent erroneous detection at the OCP_P and the OCP_M pin, insert coupling capacitor and resistance near and between the OCP_P and the OCP_M pin.

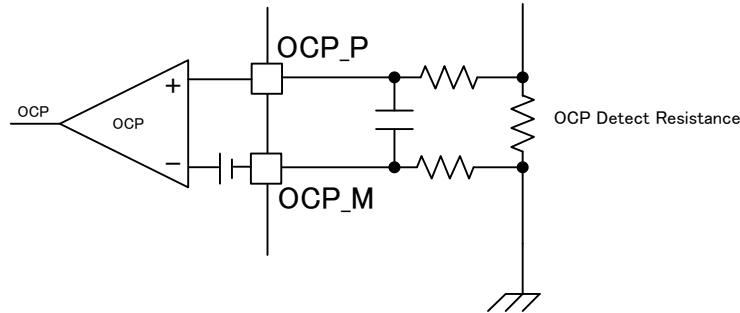

Figure 12. Circuit Diagram of Noise Measurement

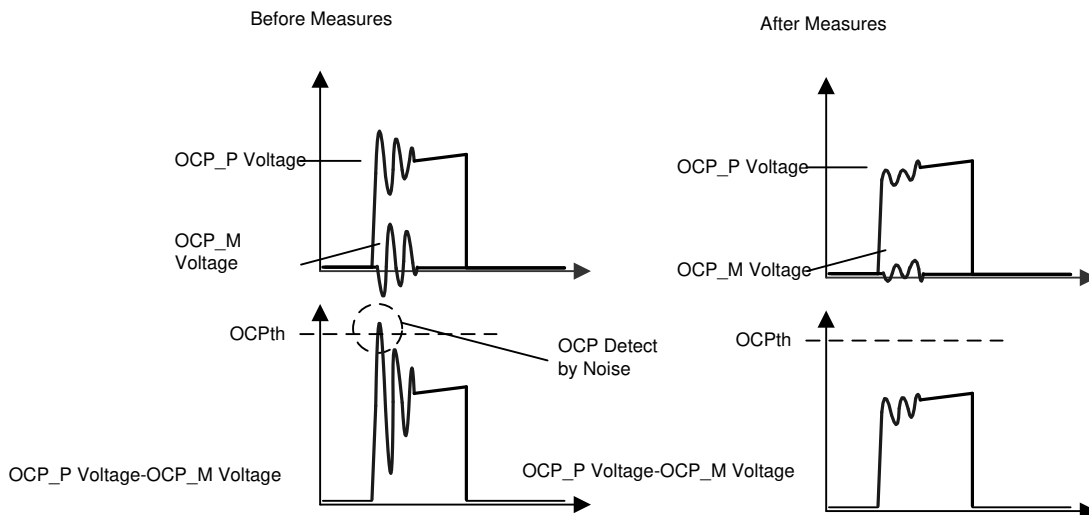

Figure 13. Effect of Noise Measurement

Consider in advance noise reduction on the board because there is limit to noise attenuation by the above measures. As precaution on pattern, make current path as short as possible, and shorten the wiring to the OCP_P and OCP_M pin as much as possible.

For peripheral components, select FET with small gate amount of charge Q_g and select Di with small equivalent capacitance and short reverse recovery time t_{RR} for noise reduction.

Aside from adding a bypass capacitor, adding an R_{GATE} makes the waveform duller (concern about the efficiency deterioration as contradictory matter).

Detailed Description – continued

● **VREG Pin Function**

The VREG pin is output pin of internal regulator and it supplies 5.0V (Typ). It drives Nch MOSFET via the OUT pin of driver output.

[Output Voltage Regenerative Function]

For the power consumption improvement of the VREG, it can regenerate to the VREG pin via diode when voltage is upper than V_{REGOV} . Voltage range that can regeneration is V_{REGOV} (5.4V (Typ)) to 10V.

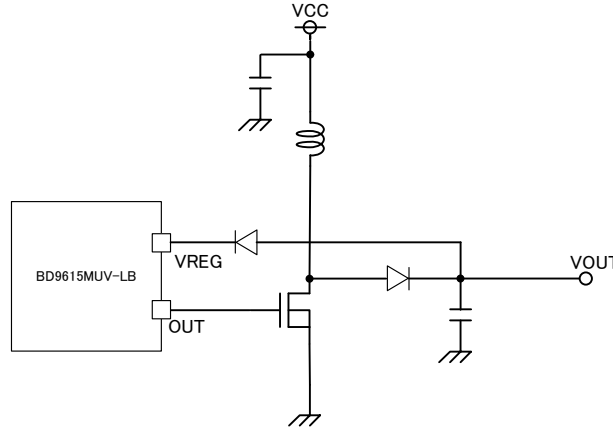

Figure 14. Example of Regeneration Application

[VCC Reduced Voltage]

Due to decrease of VCC supply voltage, drive voltage output from the VREG pin also decrease and driver R_{ON} of the OUT pin is increased.

Optimal drive voltage of FET is changed by oscillation frequency and the gate capacitance.

Selects FET and oscillation frequency that consider characteristic data when use at VCC is less than or equal to 5V.

● **Power Good Output Function**

The PGDB pin is the open drain output of the internal Nch FET. Using external resistance, pull up the PGDB pin to external power supply by external resistor, to use Power Good Output function.

When an internal detection function is the non-detection, and output voltage is within the range from UVP (the FB pin) to OVP (the MON pin), the PGDB pin is Low. When other operation mode or shutdown ($EN=L$), Nch MOSFET turns off and the PGDB pin turns HIGH (pull-up voltage).

In addition, a connection between power supply (VCC) and output (V_{OUT}) can be cut by connecting the PGDB pin like Figure 15. Pull-up voltage of the PGDB pin has to be below its absolute maximum rating of 62V.

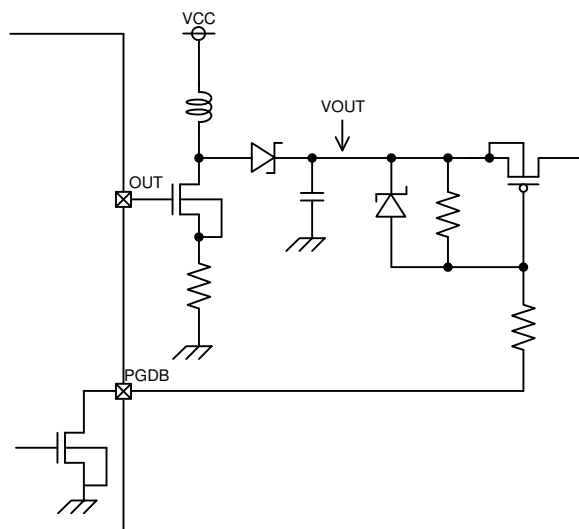

Figure 15. Circuit Diagram of Power Line Cutting Method

Performance Curves (Reference Data)
 (Unless Otherwise Specified, $T_a=25^\circ\text{C}$, $V_{CC}=12\text{V}$)

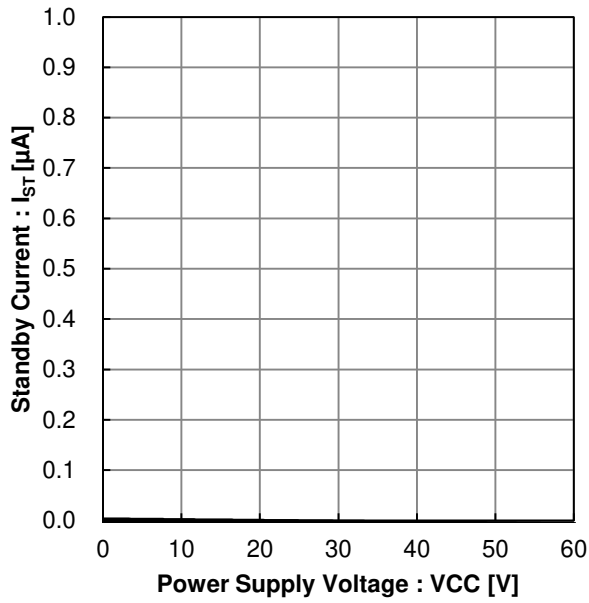

Figure 16. Standby Current vs Power Supply Voltage

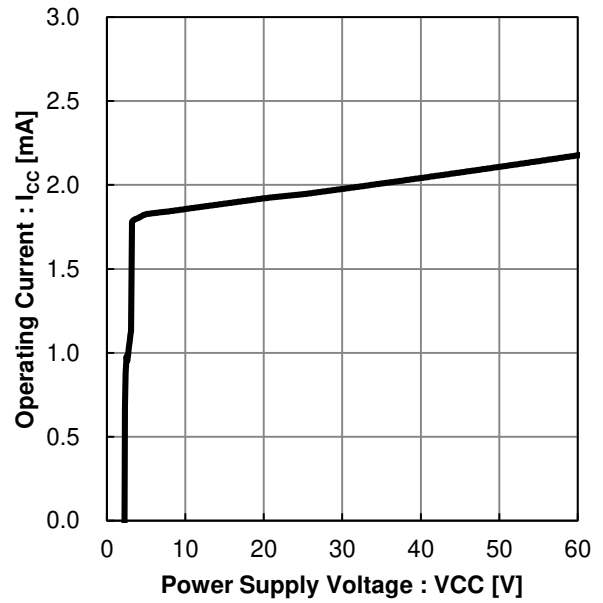

Figure 17. Operating Current vs Power Supply Voltage
 ($V_{FB}=1.2\text{V}$)

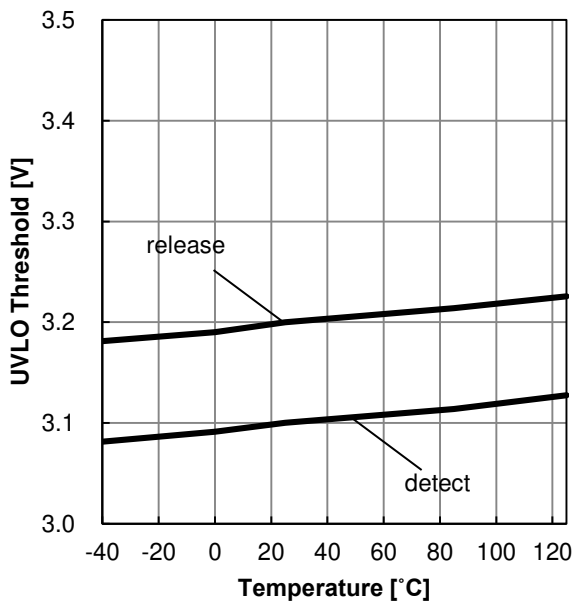

Figure 18. UVLO Threshold vs Temperature

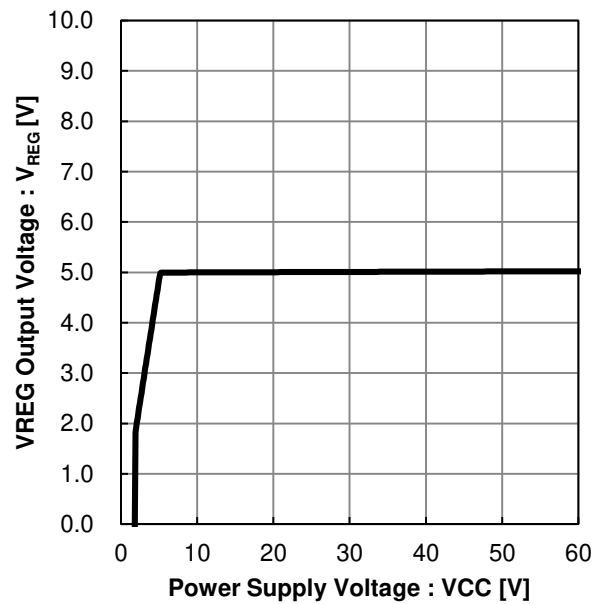

Figure 19. VREG Output Voltage vs Power Supply Voltage

Performance Curves (Reference Data) - continued

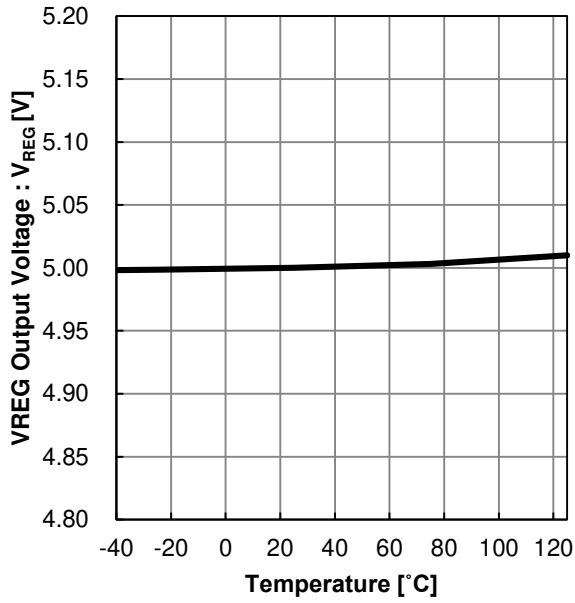

Figure 20. VREG Output Voltage vs Temperature

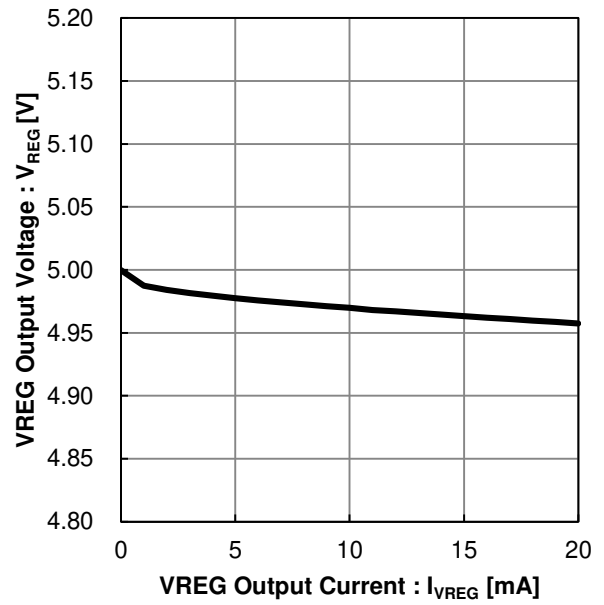

Figure 21. VREG Output Voltage vs VREG Output Current

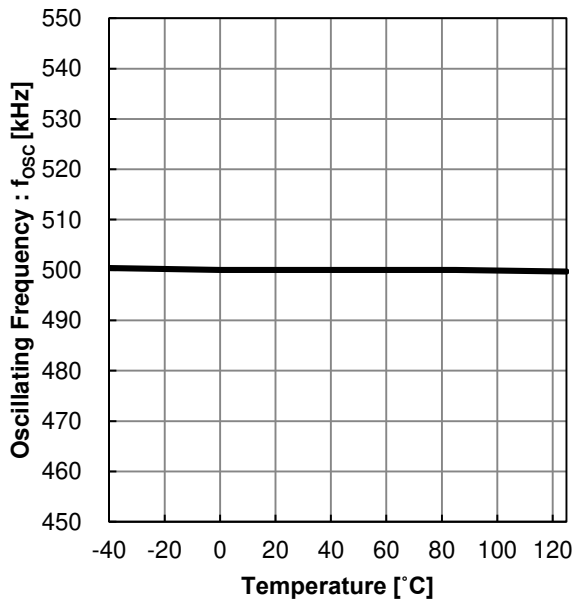

Figure 22. Oscillating Frequency vs Temperature

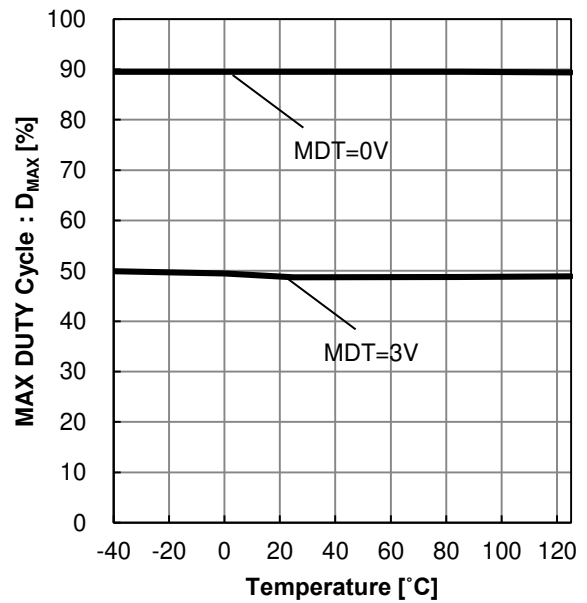

Figure 23. MAX DUTY Cycle vs Temperature

Performance Curves (Reference Data) - continued

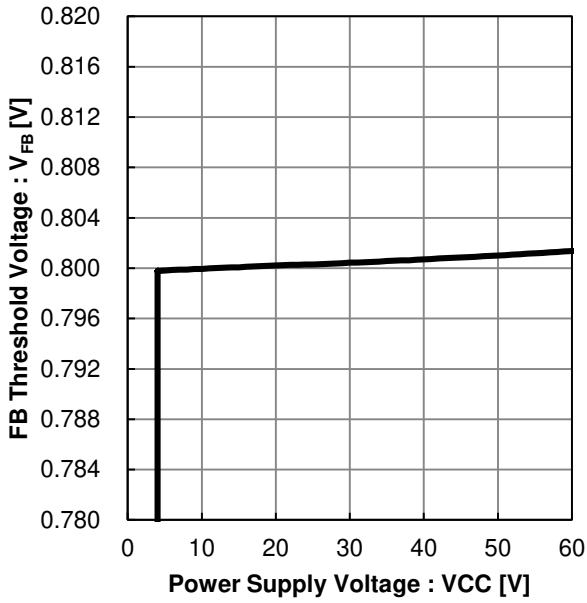

Figure 24. FB Threshold Voltage vs Power Supply Voltage

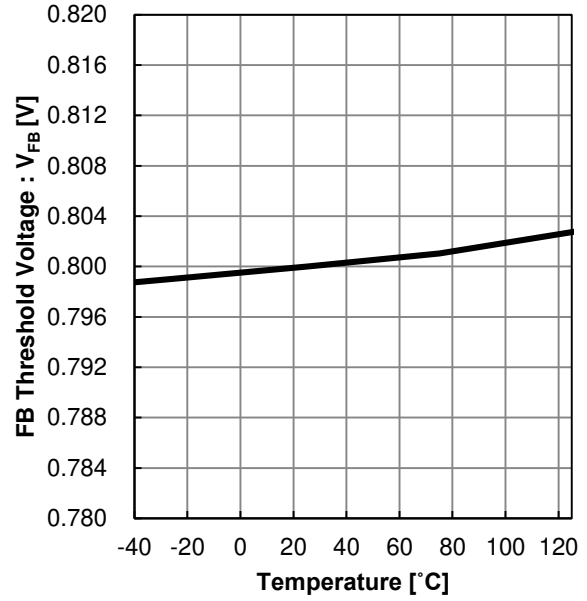

Figure 25. FB Threshold Voltage vs Temperature

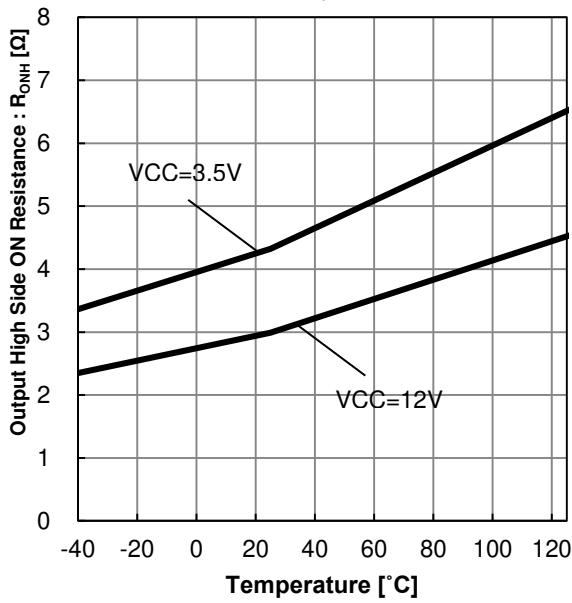

Figure 26. Output High Side ON Resistance vs Temperature

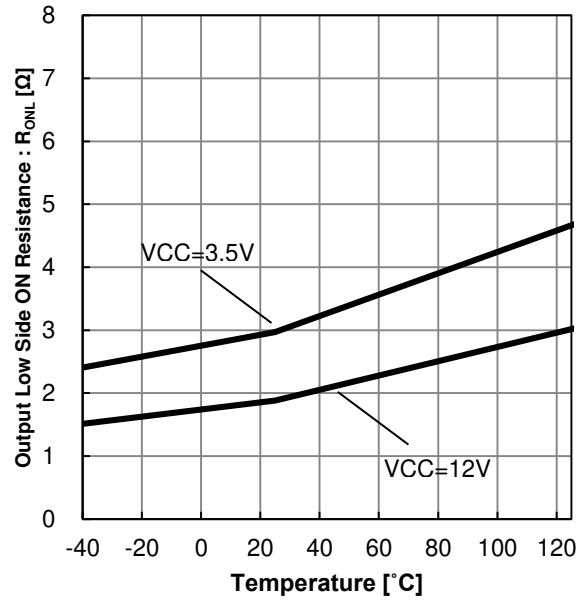

Figure 27. Output Low Side ON Resistance vs Temperature

Performance Curves (Reference Data) - continued

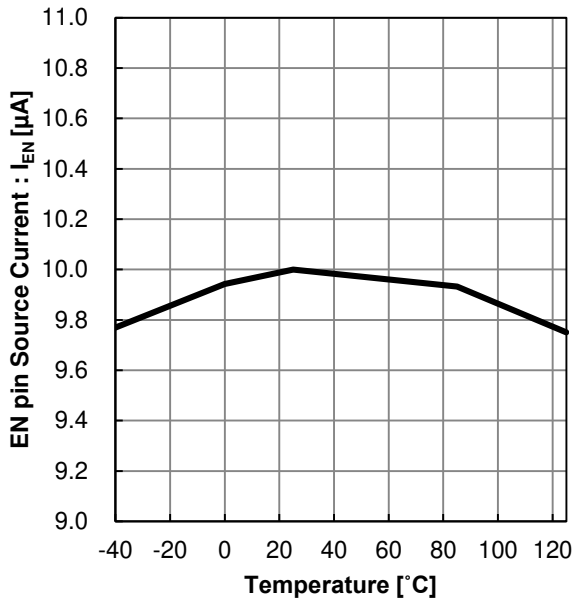

Figure 28. EN pin Source Current vs Temperature

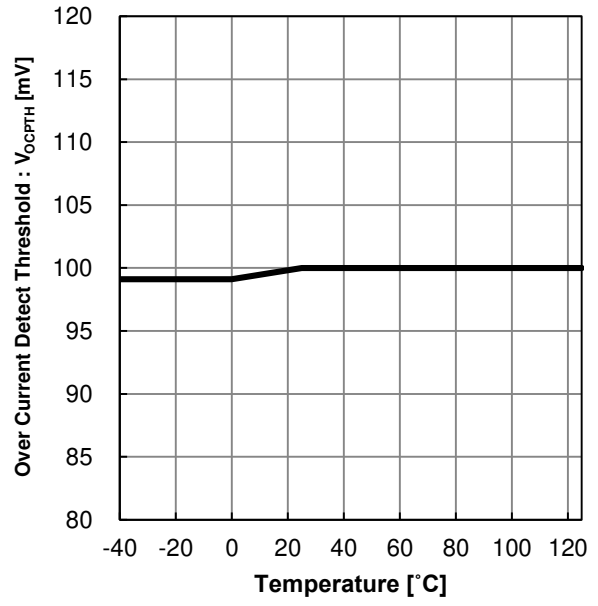
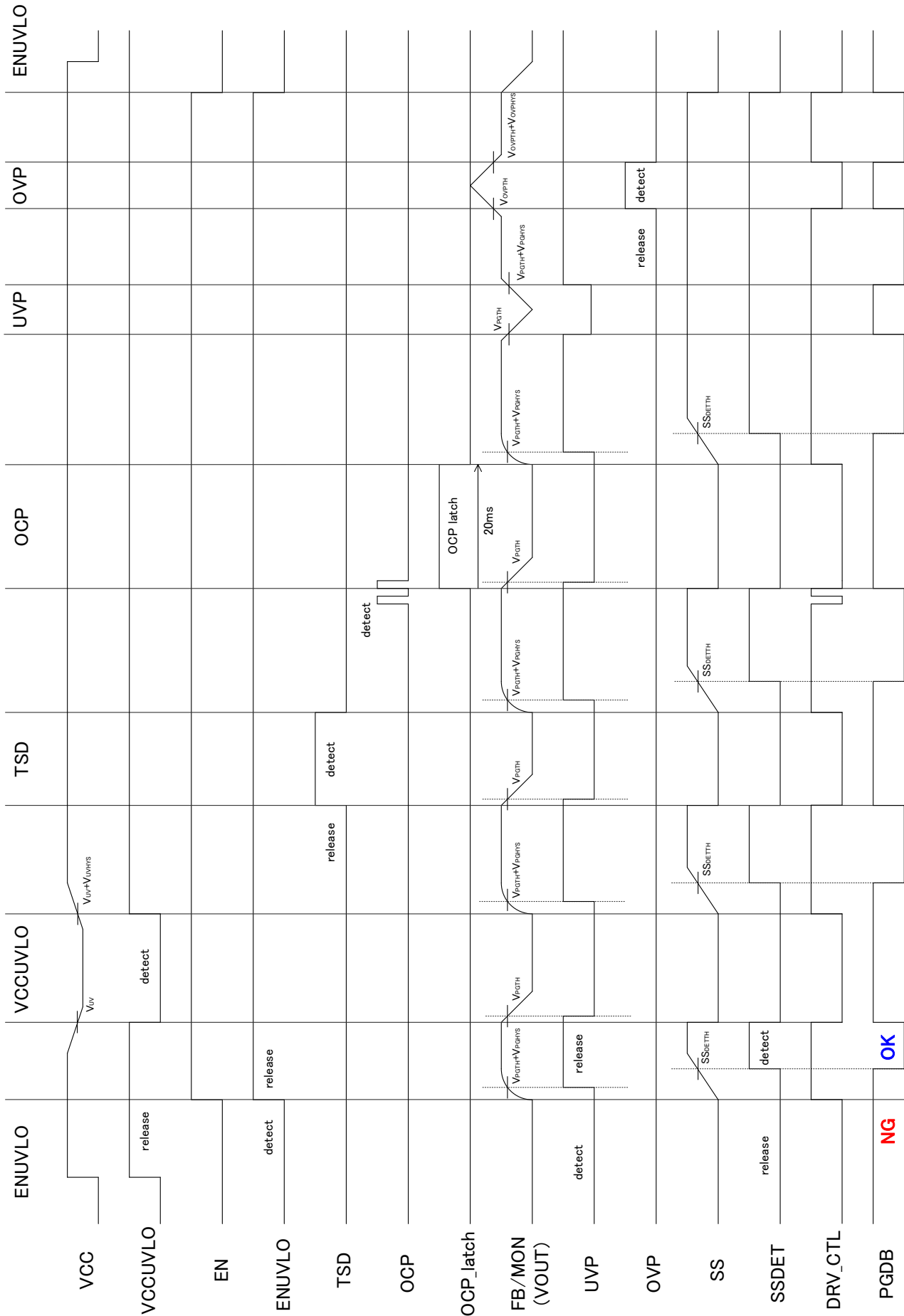

Figure 29. Over Current Detect Threshold vs Temperature

Timing Chart



Reference Characteristics of Typical Application Circuits - continued

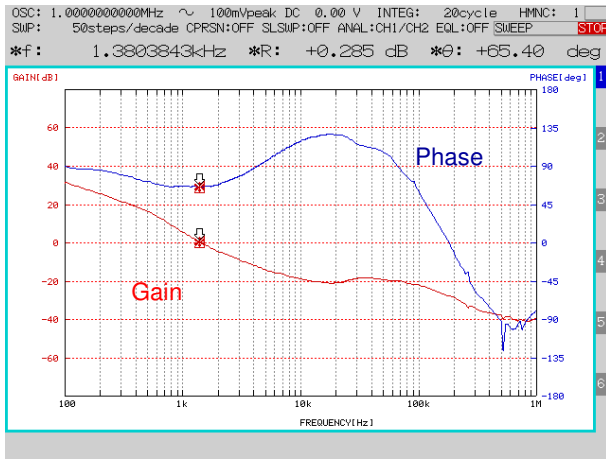

Figure 32. Frequency Characteristics Output Current=0.1A

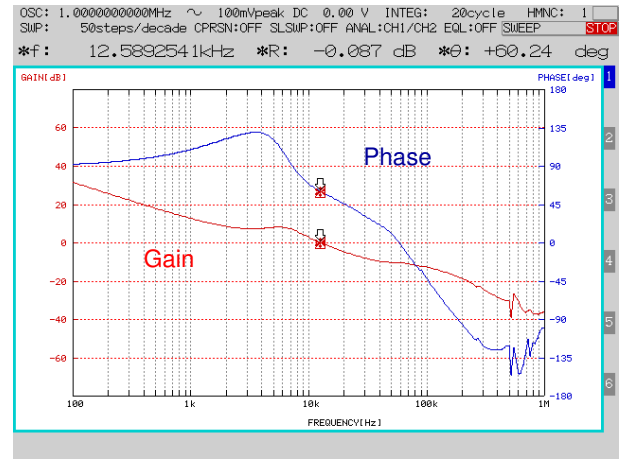

Figure 33. Frequency Characteristics Output Current=1.0A

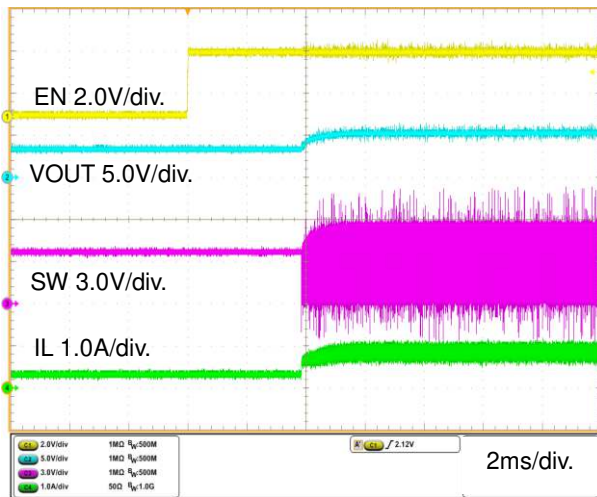

Figure 34. Startup Waveform

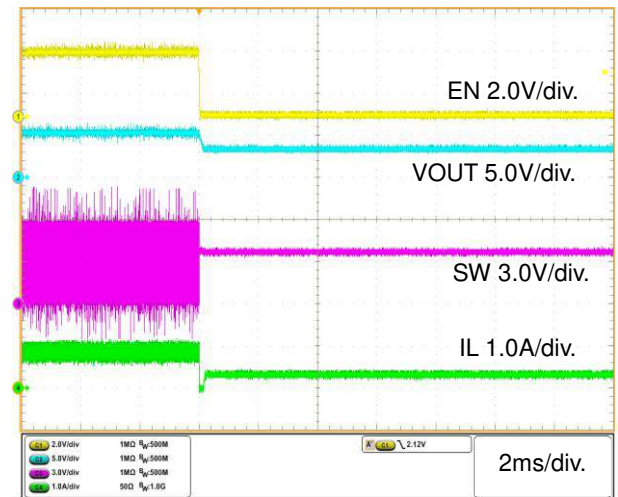

Figure 35. Shutdown Waveform

Application Part Setting Method

(1) Inductor

It is recommended to use shielded type inductor that satisfies the current rating (I_{PEAK}) and has low DCR (direct current resistance). Inductor value affects inductor ripple current and causes the output ripple. This ripple current can become small when inductor is large and switching frequency is high.

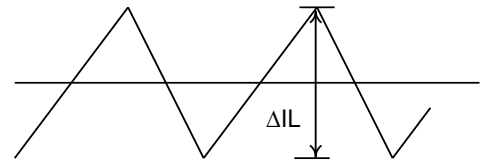

Figure 36. Inductor Current

$$I_{PEAK} = I_{OUT} \frac{V_{OUT}}{\eta \times V_{IN}} + \Delta I_L / 2 \text{ [A]} \quad (1)$$

$$\Delta I_L = \frac{V_{IN}(V_{OUT} - V_{IN})}{V_{OUT} \times f_{OSC} \times L} \text{ [A]} \quad (2)$$

where:

η is the efficiency

ΔI_L is the output ripple current

f_{OSC} is the switching frequency

Normally, ΔI_L is set 30% or less of Max Output Current (I_{OUTMAX}).

When a current flowing into the inductor exceeds the inductor current rating, it causes a magnetic saturation which causes a decrease in efficiency and oscillation at the output. Choose an inductor with a sufficient margin so that peak current does not exceed current rating of the inductor.

(2) About Switching Components FET and Di

Set switching components with sufficient margin of current tolerance obtained by the formula (1).

For noise and efficiency improvement, select FET with small input capacitance (C_{ISS} , Q_g) and ON resistance.

Select Di with small equivalent capacitance, short reverse recovery time t_{RR} , and small forward voltage V_F .

(3) Output Capacitor

Choose output capacitor with the lower Equivalent Series Resistance (ESR).

Output Ripple Voltage V_{PP} is determined in the formula (3).

$$V_{PP} = I_{OUT} \times \frac{V_{OUT} - V_{IN}}{f_{OSC} \times C_{OUT} \times V_{OUT}} + I_{PEAK} \times ESR \text{ [V]} \quad (3)$$

Set within the range of allowable ripple voltage.

The VREF pin, the VREG pin connection capacitor

Between the VREF pin, the VREG pin and the GND pin is need to connect 1 μ F ceramic capacitor.

It is needed to select capacitor from 0.5 μ F to 1.5 μ F that considers DC bias effect and temperature characteristics.

In case capacitor short Grand fault is supposed, there is a possibility of destruction by generation of heat.

Therefore, it is needed to measure set the capacitor in two series.

(4) Input Capacitor

Input capacitor needs to use electrolytic capacitor and ceramic capacitor.

Output switching current is supplied by Input Capacitor (C_{IN}), so set ceramic bypass capacitor near FET and Di.

When using electrolytic capacitor, consider the allowable ripple current.

(5) Output Voltage Setting

Output Voltage is determined in the formula (4)

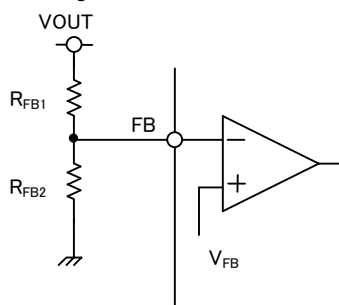

$$V_{OUT} = \frac{R_{FB1} + R_{FB2}}{R_{FB2}} \times V_{FB} \text{ [V]} \quad (4)$$

Figure 37. Circuit Diagram of Voltage Feedback Resistor Setting Method

Application Part Setting Method - continued

(6) Selection of External Phase Compensation

Stable condition of application

Negative feedback is applied as follows.

When Gain is 1(0dB), phase delay is 135 degrees or less (phase margin is 45 degrees or more).

DC/DC converter application is sampled by switching frequency, so as a whole f_{BW} (frequency at which gain is 0dB) is set 1/10 or less of the switching frequency.

Also set f_{BW} in less than 1/5 of boost converter peculiar right half plane zero (f_{RHPZ}) so that right half plane zero frequency does not influence a control loop.

In conclusion, Application target specifications are as follows.

(A) Gain is 1 (0dB), phase delay is 135 degrees or less (phase margin is 45 degrees or more).

(B) f_{BW} is 1/10 or less of switching frequency

(C) f_{BW} is 1/5 or less of f_{RHPZ}

It set C_1 , C_3 , R_1 , and R_2 of Figure 38 that meet the above.

f_{BW} that determines DC/DC converter responsiveness is able to calculate by evaluate 1st pole frequency and DC gain.

$$\text{1st pole frequency } fp1 = \frac{1}{(2\pi \times A \times \frac{R_{FB1} \times R_{FB2} \times C_3}{R_{FB1} + R_{FB2}})} \text{ [Hz]}$$

$$\text{DC Gain } DCgain = \frac{A}{B} \times V_{FB} \times \frac{V_{OUT}}{V_{IN}}$$

Where

A: ERROR Amp Gain=10⁴ (=80dB)

B: Oscillator amplitude=0.5V

$$f_{BW} = DCgain \times fp1 \text{ [Hz]}$$

$$f_{RHPZ} = \frac{1}{2 \times \pi \times L \times I_{OUT}} \times \frac{V_{IN}^2}{V_{OUT}} \text{ [Hz]}$$

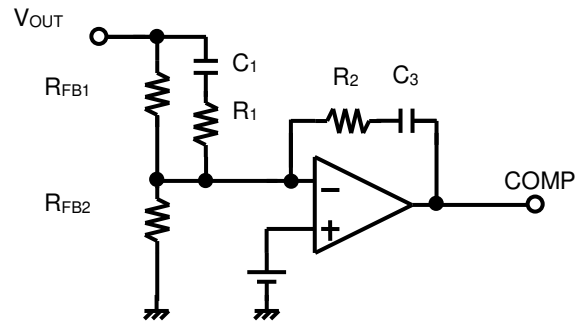

Figure 38. Example of Phase Compensation Setting

Insert second order phase lead in order to cancel the second order phase delay by LC. Insert phase lead near LC resonance frequency.

$$\text{Phase Lead } fz1 = \frac{1}{2\pi \times R_{FB1} \times C_1} \text{ [Hz]}$$

$$\text{Phase Lead } fz2 = \frac{1}{2 \times \pi \times R_2 \times C_3} \text{ [Hz]}$$

$$\text{LC Resonance Frequency} = \frac{1-D}{2 \times \pi \times \sqrt{L \times C_{OUT}}} \text{ [Hz]}$$

Where

C_{OUT} : Output Capacitor

D: ON Duty=($V_{OUT}-V_{IN}$)/ V_{OUT}

If f_{BW} goes excessive high frequency by second order phase lead, it may be stabilized by inserting first order phase delay to frequency above LC resonance frequency to further compensate it.

$$\text{Phase Delay } fp2 = \frac{1}{2 \times \pi \times R_1 \times C_1} \text{ [Hz]}$$

PCB Layout

Consider the following general points to bring out the IC performance.

1. Each input of the OCP_P pin and the OCP_M pin are very sensitive. Consider the above-mentioned contents.
2. For noise caused by parasitic capacitance coupling, consider routing by keep distance to providing a buffer zone. Especially wiring those are sensitive to noise such as the OCP_P pin, the OCP_M pin and the COMP pin.
3. Near the OCP_P pin, the OCP_M pin and phase compensation circuit need to set pre-pattern about capacitor as insurance.
4. Place the bypass capacitor near the input of the IC, FET, and Di and wire it as short as possible.
5. Be careful not to have common impedance to high current system with analog system VCC (GND).

I/O Equivalence Circuit

Pin No.	Pin Name	Pin Equivalence Circuit	Pin No.	Pin Name	Pin Equivalence Circuit
1	SYNC		5	MON	
2	MDT		6	COMP	
3	RT		7	FB	
4	SS		8	OCP_P	

I/O Equivalence Circuit - continued

Pin No.	Pin Name	Pin Equivalence Circuit	Pin No.	Pin Name	Pin Equivalence Circuit
9	OCP_M		14	EN	
11	OUT		15	VREF	
12	VREG		16	PGDB	

Operational Notes

1. Reverse Connection of Power Supply

Connecting the power supply in reverse polarity can damage the IC. Take precautions against reverse polarity when connecting the power supply, such as mounting an external diode between the power supply and the IC's power supply pins.

2. Power Supply Lines

Design the PCB layout pattern to provide low impedance supply lines. Furthermore, connect a capacitor to ground at all power supply pins. Consider the effect of temperature and aging on the capacitance value when using electrolytic capacitors.

3. Ground Voltage

Ensure that no pins are at a voltage below that of the ground pin at any time, even during transient condition.

4. Ground Wiring Pattern

When using both small-signal and large-current ground traces, the two ground traces should be routed separately but connected to a single ground at the reference point of the application board to avoid fluctuations in the small-signal ground caused by large currents. Also ensure that the ground traces of external components do not cause variations on the ground voltage. The ground lines must be as short and thick as possible to reduce line impedance.

5. Recommended Operating Conditions

The function and operation of the IC are guaranteed within the range specified by the recommended operating conditions. The characteristic values are guaranteed only under the conditions of each item specified by the electrical characteristics.

6. Inrush Current

When power is first supplied to the IC, it is possible that the internal logic may be unstable and inrush current may flow instantaneously due to the internal powering sequence and delays, especially if the IC has more than one power supply. Therefore, give special consideration to power coupling capacitance, power wiring, width of ground wiring, and routing of connections.

7. Operation Under Strong Electromagnetic Field

Operating the IC in the presence of a strong electromagnetic field may cause the IC to malfunction.

8. Testing on Application Boards

When testing the IC on an application board, connecting a capacitor directly to a low-impedance output pin may subject the IC to stress. Always discharge capacitors completely after each process or step. The IC's power supply should always be turned off completely before connecting or removing it from the test setup during the inspection process. To prevent damage from static discharge, ground the IC during assembly and use similar precautions during transport and storage.

9. Inter-pin Short and Mounting Errors

Ensure that the direction and position are correct when mounting the IC on the PCB. Incorrect mounting may result in damaging the IC. Avoid nearby pins being shorted to each other especially to ground, power supply and output pin. Inter-pin shorts could be due to many reasons such as metal particles, water droplets (in very humid environment) and unintentional solder bridge deposited in between pins during assembly to name a few.

10. Unused Input Pins

Input pins of an IC are often connected to the gate of a MOS transistor. The gate has extremely high impedance and extremely low capacitance. If left unconnected, the electric field from the outside can easily charge it. The small charge acquired in this way is enough to produce a significant effect on the conduction through the transistor and cause unexpected operation of the IC. So unless otherwise specified, unused input pins should be connected to the power supply or ground line.

Operational Notes – continued

11. Regarding the Input Pin of the IC

This monolithic IC contains P+ isolation and P substrate layers between adjacent elements in order to keep them isolated. P-N junctions are formed at the intersection of the P layers with the N layers of other elements, creating a parasitic diode or transistor. For example (refer to figure below):

When $GND > Pin A$ and $GND > Pin B$, the P-N junction operates as a parasitic diode.

When $GND > Pin B$, the P-N junction operates as a parasitic transistor.

Parasitic diodes inevitably occur in the structure of the IC. The operation of parasitic diodes can result in mutual interference among circuits, operational faults, or physical damage. Therefore, conditions that cause these diodes to operate, such as applying a voltage lower than the GND voltage to an input pin (and thus to the P substrate) should be avoided.

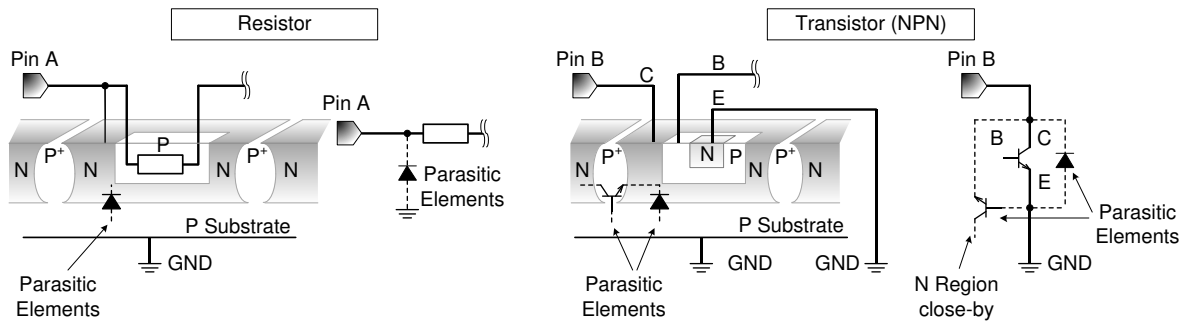

Figure 39. Example of monolithic IC structure

12. Ceramic Capacitor

When using a ceramic capacitor, determine a capacitance value considering the change of capacitance with temperature and the decrease in nominal capacitance due to DC bias and others.

13. Thermal Shutdown Circuit(TSD)

This IC has a built-in thermal shutdown circuit that prevents heat damage to the IC. Normal operation should always be within the IC's maximum junction temperature rating. If however the rating is exceeded for a continued period, the junction temperature (T_j) will rise which will activate the TSD circuit that will turn OFF power output pins. When the T_j falls below the TSD threshold, the circuits are automatically restored to normal operation.

Note that the TSD circuit operates in a situation that exceeds the absolute maximum ratings and therefore, under no circumstances, should the TSD circuit be used in a set design or for any purpose other than protecting the IC from heat damage.

14. Over Current Protection Circuit (OCP)

This IC incorporates an integrated overcurrent protection circuit that is activated when the load is shorted. This protection circuit is effective in preventing damage due to sudden and unexpected incidents. However, the IC should not be used in applications characterized by continuous operation or transitioning of the protection circuit.

Ordering Information

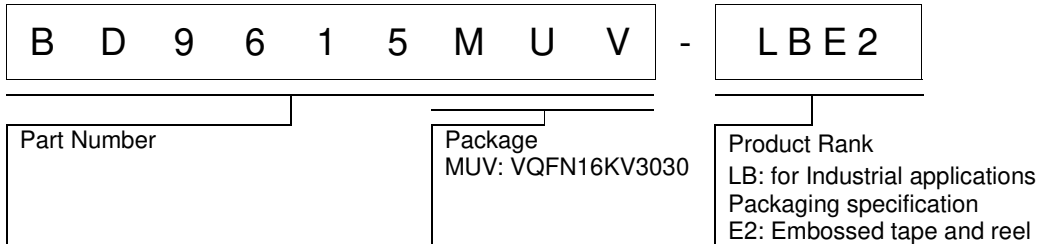

Marking Diagram

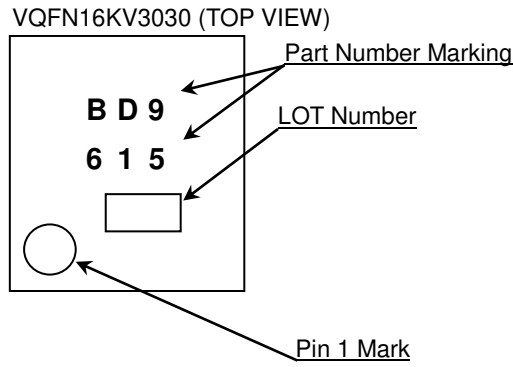

Physical Dimension and Packing Information

Package Name	VQFN16KV3030
--------------	--------------

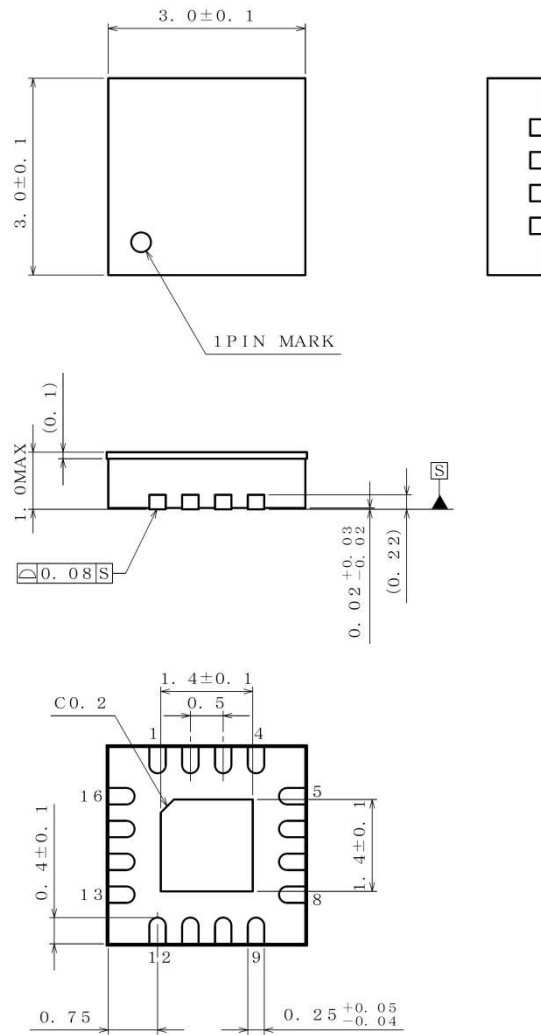

(UNIT : mm)

PKG : VQFN16KV3030
Drawing No. EX408-5001

<Tape and Reel information>

Tape	Embossed carrier tape
Quantity	3000pcs
Direction of feed	E2 (The direction is the 1pin of product is at the upper left when you hold reel on the left hand and you pull out the tape on the right hand)

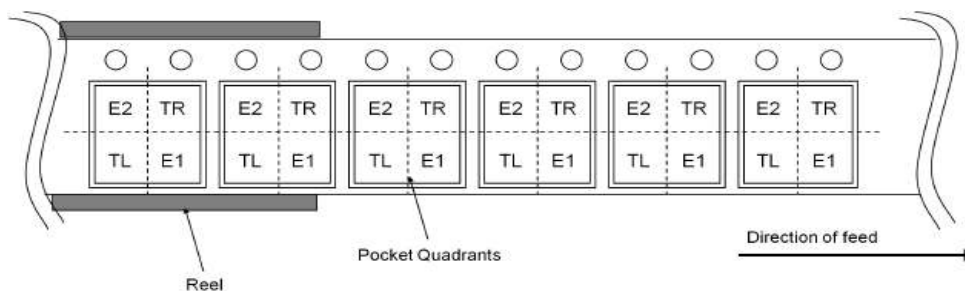

Revision History

Date	Revision	Changes
24.Apr.2018	001	New release
21.jun.2018	002	The Package Name was changed. VQFN16SV3030 → VQFN16KV3030
07.May.2020	003	Add the value to Electrical Characteristics. V _{VVHYS} Min, V _{REGOVHYS} Min, R _{ONH} Min/Max, R _{ONL} Min/Max

Notice

Precaution on using ROHM Products

1. If you intend to use our Products in devices requiring extremely high reliability (such as medical equipment ^(Note 1), aircraft/spacecraft, nuclear power controllers, etc.) and whose malfunction or failure may cause loss of human life, bodily injury or serious damage to property ("Specific Applications"), please consult with the ROHM sales representative in advance. Unless otherwise agreed in writing by ROHM in advance, ROHM shall not be in any way responsible or liable for any damages, expenses or losses incurred by you or third parties arising from the use of any ROHM's Products for Specific Applications.

(Note1) Medical Equipment Classification of the Specific Applications

JAPAN	USA	EU	CHINA
CLASS III	CLASS III	CLASS II b	CLASS III
CLASS IV		CLASS III	

2. ROHM designs and manufactures its Products subject to strict quality control system. However, semiconductor products can fail or malfunction at a certain rate. Please be sure to implement, at your own responsibilities, adequate safety measures including but not limited to fail-safe design against the physical injury, damage to any property, which a failure or malfunction of our Products may cause. The following are examples of safety measures:
 - [a] Installation of protection circuits or other protective devices to improve system safety
 - [b] Installation of redundant circuits to reduce the impact of single or multiple circuit failure
3. Our Products are not designed under any special or extraordinary environments or conditions, as exemplified below. Accordingly, ROHM shall not be in any way responsible or liable for any damages, expenses or losses arising from the use of any ROHM's Products under any special or extraordinary environments or conditions. If you intend to use our Products under any special or extraordinary environments or conditions (as exemplified below), your independent verification and confirmation of product performance, reliability, etc. prior to use, must be necessary:
 - [a] Use of our Products in any types of liquid, including water, oils, chemicals, and organic solvents
 - [b] Use of our Products outdoors or in places where the Products are exposed to direct sunlight or dust
 - [c] Use of our Products in places where the Products are exposed to sea wind or corrosive gases, including Cl₂, H₂S, NH₃, SO₂, and NO₂
 - [d] Use of our Products in places where the Products are exposed to static electricity or electromagnetic waves
 - [e] Use of our Products in proximity to heat-producing components, plastic cords, or other flammable items
 - [f] Sealing or coating our Products with resin or other coating materials
 - [g] Use of our Products without cleaning residue of flux (Exclude cases where no-clean type fluxes is used. However, recommend sufficiently about the residue.); or Washing our Products by using water or water-soluble cleaning agents for cleaning residue after soldering
 - [h] Use of the Products in places subject to dew condensation
4. The Products are not subject to radiation-proof design.
5. Please verify and confirm characteristics of the final or mounted products in using the Products.
6. In particular, if a transient load (a large amount of load applied in a short period of time, such as pulse, is applied, confirmation of performance characteristics after on-board mounting is strongly recommended. Avoid applying power exceeding normal rated power; exceeding the power rating under steady-state loading condition may negatively affect product performance and reliability.
7. De-rate Power Dissipation depending on ambient temperature. When used in sealed area, confirm that it is the use in the range that does not exceed the maximum junction temperature.
8. Confirm that operation temperature is within the specified range described in the product specification.
9. ROHM shall not be in any way responsible or liable for failure induced under deviant condition from what is defined in this document.

Precaution for Mounting / Circuit board design

1. When a highly active halogenous (chlorine, bromine, etc.) flux is used, the residue of flux may negatively affect product performance and reliability.
2. In principle, the reflow soldering method must be used on a surface-mount products, the flow soldering method must be used on a through hole mount products. If the flow soldering method is preferred on a surface-mount products, please consult with the ROHM representative in advance.

For details, please refer to ROHM Mounting specification

Precautions Regarding Application Examples and External Circuits

1. If change is made to the constant of an external circuit, please allow a sufficient margin considering variations of the characteristics of the Products and external components, including transient characteristics, as well as static characteristics.
2. You agree that application notes, reference designs, and associated data and information contained in this document are presented only as guidance for Products use. Therefore, in case you use such information, you are solely responsible for it and you must exercise your own independent verification and judgment in the use of such information contained in this document. ROHM shall not be in any way responsible or liable for any damages, expenses or losses incurred by you or third parties arising from the use of such information.

Precaution for Electrostatic

This Product is electrostatic sensitive product, which may be damaged due to electrostatic discharge. Please take proper caution in your manufacturing process and storage so that voltage exceeding the Products maximum rating will not be applied to Products. Please take special care under dry condition (e.g. Grounding of human body / equipment / solder iron, isolation from charged objects, setting of ionizer, friction prevention and temperature / humidity control).

Precaution for Storage / Transportation

1. Product performance and soldered connections may deteriorate if the Products are stored in the places where:
 - [a] the Products are exposed to sea winds or corrosive gases, including Cl₂, H₂S, NH₃, SO₂, and NO₂
 - [b] the temperature or humidity exceeds those recommended by ROHM
 - [c] the Products are exposed to direct sunshine or condensation
 - [d] the Products are exposed to high Electrostatic
2. Even under ROHM recommended storage condition, solderability of products out of recommended storage time period may be degraded. It is strongly recommended to confirm solderability before using Products of which storage time is exceeding the recommended storage time period.
3. Store / transport cartons in the correct direction, which is indicated on a carton with a symbol. Otherwise bent leads may occur due to excessive stress applied when dropping of a carton.
4. Use Products within the specified time after opening a humidity barrier bag. Baking is required before using Products of which storage time is exceeding the recommended storage time period.

Precaution for Product Label

A two-dimensional barcode printed on ROHM Products label is for ROHM's internal use only.

Precaution for Disposition

When disposing Products please dispose them properly using an authorized industry waste company.

Precaution for Foreign Exchange and Foreign Trade act

Since concerned goods might be fallen under listed items of export control prescribed by Foreign exchange and Foreign trade act, please consult with ROHM in case of export.

Precaution Regarding Intellectual Property Rights

1. All information and data including but not limited to application example contained in this document is for reference only. ROHM does not warrant that foregoing information or data will not infringe any intellectual property rights or any other rights of any third party regarding such information or data.
2. ROHM shall not have any obligations where the claims, actions or demands arising from the combination of the Products with other articles such as components, circuits, systems or external equipment (including software).
3. No license, expressly or implied, is granted hereby under any intellectual property rights or other rights of ROHM or any third parties with respect to the Products or the information contained in this document. Provided, however, that ROHM will not assert its intellectual property rights or other rights against you or your customers to the extent necessary to manufacture or sell products containing the Products, subject to the terms and conditions herein.

Other Precaution

1. This document may not be reprinted or reproduced, in whole or in part, without prior written consent of ROHM.
2. The Products may not be disassembled, converted, modified, reproduced or otherwise changed without prior written consent of ROHM.
3. In no event shall you use in any way whatsoever the Products and the related technical information contained in the Products or this document for any military purposes, including but not limited to, the development of mass-destruction weapons.
4. The proper names of companies or products described in this document are trademarks or registered trademarks of ROHM, its affiliated companies or third parties.

General Precaution

1. Before you use our Products, you are requested to carefully read this document and fully understand its contents. ROHM shall not be in any way responsible or liable for failure, malfunction or accident arising from the use of any ROHM's Products against warning, caution or note contained in this document.
2. All information contained in this document is current as of the issuing date and subject to change without any prior notice. Before purchasing or using ROHM's Products, please confirm the latest information with a ROHM sales representative.
3. The information contained in this document is provided on an "as is" basis and ROHM does not warrant that all information contained in this document is accurate and/or error-free. ROHM shall not be in any way responsible or liable for any damages, expenses or losses incurred by you or third parties resulting from inaccuracy or errors of or concerning such information.