

PART NUMBER	REVISION	DESCRIPTION	FEED TYPE
2266422-1	C	FINE CRIMP HEIGHT ADJUST	MECHANICAL
2266422-2	C	FINE CRIMP HEIGHT ADJUST	PNEUMATIC
7-2266422-1	C	MECHANICAL AND CRIMP TOOLING KIT	MECHANICAL
7-2266422-2	C	PNEUMATIC AND CRIMP TOOLING KIT	PNEUMATIC
7-2266422-7	A	CRIMP TOOLING KIT	-

ATLANTIC VERSION TERMINATOR INTERFACE ADAPTER

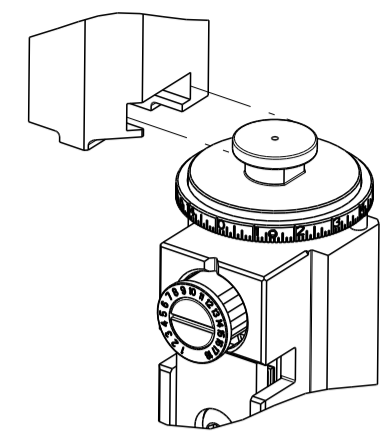

APPLICATOR DATA		
CRIMP	SIZE	TYPE
WIRE	1.00 mm [.039]	F
INSUL	1.07 mm [.042]	O

APPLICATOR INSTRUCTIONS
408-35042

TERMINAL DATA: MOLEX TERMINAL		MOLEX CRIMP SPECIFICATION	
TERMINAL NAME: CTX50 RECEPTACLE-UNSEALED			
WIRE STRIP LENGTH		INSULATION DIAMETER RANGE	
2.60-3.00 mm [.102-.118 IN]		Ø0.95-1.20 mm [.037-.047 IN]	
TERMINAL APPLICATION SPECIFICATION	63901-4900 Rev C		
TERMINALS APPLIED			
TE TERMINAL	MOLEX TERMINAL	TE TERMINAL	MOLEX TERMINAL
2113536-1	560023-0421		

WIRE SIZE	CRIMP HEIGHT mm [INCH]	CRIMP HEIGHT REFERENCE SETTING
0.35mm2	0.72 +/- 0.03 [.028 +/- .001]	5.6
0.22mm2	0.69 +/- 0.03 [.027 +/- .001]	5.7

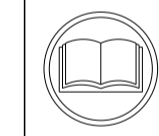

- RECOMMENDED SPARE PARTS
- REFER TO SUPPLIED INSTRUCTION SHEET FOR CLEANING, LUBRICATION AND STORAGE OF APPLICATOR.
- APPLY PART NUMBER 2-23419-6 LOCTITE TO THREADS OF ITEM 242.
- CRIMP HEIGHT REFERENCE SETTING WAS THE SETTING USED WHEN THE APPLICATOR WAS QUALIFIED AT THE FACTORY. ADJUSTMENT MAY BE NECESSARY WHEN RUNNING APPLICATOR IN THE FIELD.
- TERMINAL LUBRICANT IS RECOMMENDED.
- 6. UNLESS SPECIFIED OTHERWISE TORQUE VALUES SHALL BE USED PER DOCUMENT, 101-35000.

***WARNING**
ON INSTALLATION, SET WIRE DISC TO CRIMP HEIGHT REFERENCE SETTING FOR LARGEST WIRE SIZE. CRIMP HEIGHT REFERENCE SETTINGS GREATER THAN THE VALUE SHOWN MAY CAUSE DAMAGE TO THE CRIMP TOOLING. REFER TO THE INSTRUCTION SHEET FOR PROPER SETUP AND ADJUSTMENTS.

LOC	DIST	REVISIONS					
A	66	P	LTN	DESCRIPTION	DATE	OWN	APVD
		B		ECR-17-001825	09FEB2017	TB	CT
		C		ECR-22-140612	26MAY2022	TB	RK

-	1	-	1	-	2119641-1	FEED CAM, AIR FEED	248	
-	1	1	1	1	2119082-5	CAM, SNAIL, INSULATION ADJUSTMENT	244	
-	1	1	1	1	2079764-1	WASHER, WAVE SPRING, CREST-TO-CREST	243	
-	1	1	1	1	2119083-1	RETAINER, INSULATION DIAL	242	
-	1	1	1	1	7-18023-7	SCR, SKT HD CAP M3 X 4.0	241	
-	-	1	-	1	2119580-1	MECHANICAL FEED ASSEMBLY	239	
-	1	-	1	-	2844940-1	AIR FEED MODULE	238	
-	REF	REF	REF	REF	994970-2	COUNTER, MAGNETIC	164	
-	1	1	1	1	2119955-1	ASSY, LUBRICATOR, SIDE FEED	113	
-	1	1	1	1	2844908-1	SCREW, LOCKING	99	
-	1	1	1	1	2844907-1	POST, LOCKING	98	
-	1	1	1	1	455888-5	SPACER, CRIMPER	82	
-	1	1	1	1	5-547505-2	SPRING, COMPRESSION	77	
-	1	1	1	1	854769-4	HOLDER, INS	74	
-	1	1	1	1	1803607-3	DOCUMENTATION PACKAGE	71	
-	1	1	1	1	2119740-1	TAG, IDENTIFICATION	67	
-	2	2	2	2	2168078-1	SCREW, DRIVE, RH, RoHS, 2 x .188	66	
-	1	1	1	1	2168083-2	SCR, SKT HD CAP, RoHS, M4 X 8.0	60	
-	1	1	1	1	5-18022-5	SCR, HEX HD CAP, M4 X 6.0	59	
-	1	1	1	1	21028-2	PIN, SLOTTED SPRING .062 X .250	58	
-	1	1	1	1	1338685-1	PAWL, FEED	56	
-	4	4	4	4	2168083-3	SCR, SKT HD CAP, RoHS, M4 X 12.0	54	
-	2	2	2	2	1-2168083-0	SCR, SKT HD CAP, RoHS, M4 X 10	53	
-	1	1	1	1	5018030-1	NUT, HEX, REG, RoHS, M3	52	
-	1	1	1	1	811242-5	BUMPER, HOLD DOWN	51	
-	1	1	1	1	690753-2	SPACER, TONKER	50	
-	1	2	1	2	18023-9	SCR, SKT HD CAP M4 X 6.0	49	
-	-	1	-	1	2119652-1	FEED CAM, PRE FEED	48	
-	-	1	-	1	2119653-1	FEED CAM, POST FEED	47	
-	1	1	1	1	1803583-9	APPLICATOR BASIC ASSEMBLY, SF	46	
-	1	1	1	1	1803515-1	RAM ASSEMBLY, SF ATLANTIC	44	
-	1	1	1	1	1803602-1	SCR, BHSC, RoHS (M8 X 25)	41	
-	1	1	1	1	1752356-3	SUPPORT, TERMINAL	34	
-	2	2	2	2	2079383-5	SCR, BHSC, RoHS (M4 X 20)	33	
-	2	2	2	2	2-2844962-3	SPACER, CYLINDRICAL, STRIP GUIDE	30	
-	1	1	1	1	2844992-1	ASSEMBLY, STRIP GUIDE	29	
-	1	1	1	1	455888-3	SPACER, CRIMPER	28	
-	1	1	1	1	1320928-2	STRIP GUIDE	24	
-	1	1	1	1	2168083-2	SCR, SKT HD CAP, RoHS, M4 X 8.0	21	
-	2	2	2	2	1-18028-2	WASHER, FLAT, REG M4	20	
-	1	1	1	1	2119533-1	STRIPPER, SIDE FEED	19	
-	1	1	1	1	2119806-1	INSERT, SHEAR	13	
-	1	1	1	1	3-22280-3	SPRING, COMPRESSION	12	
-	1	1	1	1	1-356885-4	STOP, SHEAR	11	
-	1	1	1	1	2119805-1	SHEAR HOLDER, FRONT	10	
-	1	1	1	1	1803095-6	FLOATING SHEAR, FRONT	9	
-	1	2	2	1	1	7-1633932-2	ANVIL, COMBINATION	8
-	-	-	-	-	-	-	7	
-	-	-	-	-	-	-	6	
-	1	1	1	1	2119780-6	DEPRESSOR, SHEAR	5	
-	1	1	1	1	4-238011-1	BLOCK, CRIMPER SPACER	4	
-	1	2	2	1	1	1-1633966-8	CRIMPER, INSULATION O	3
-	-	-	-	-	-	-	2	
-	1	2	2	1	1	9-1633609-8	CRIMPER, WIRE	1
-	77	-72	-71	-2	-1	PART NO	DESCRIPTION	ITEM NO

ATLANTIC VERSION
Shown on sheets 1 of 4 & 2 of 4
(Pacific version shown on sheets 3 of 4 & 4 of 4)

DIMENSIONS:		TOLERANCES UNLESS OTHERWISE SPECIFIED:		MATERIAL:		FINISH:	
mm	0 PLC ±	1 PLC ±	2 PLC ±	3 PLC ±	4 PLC ±	ANGLES ±	FINISH ±
MATERIAL:		FINISH:		WEIGHT:		SCALE:	
Customer Accessible Production Drawing		SCALE: 1:2		SHEET 1 OF 4		REV C	

LOC	DIST	REV	DESCRIPTION	DATE	OWN	APVD
		1	rev. sym. 1866.8H6E111		rev. defect	dmv_bppr
		2	rev. sym. 2 rev. desc. 2		rev. defect	dmv_bppr
		3	rev. sym. 3 rev. desc. 3		rev. defect	dmv_bppr
		4	rev. sym. 4 rev. desc. 4		rev. defect	dmv_bppr

FEED TYPE MECHANICAL

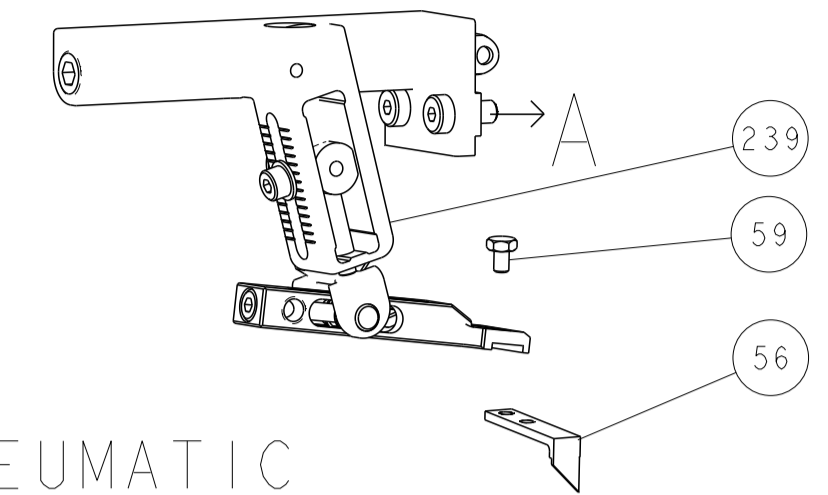

PNEUMATIC

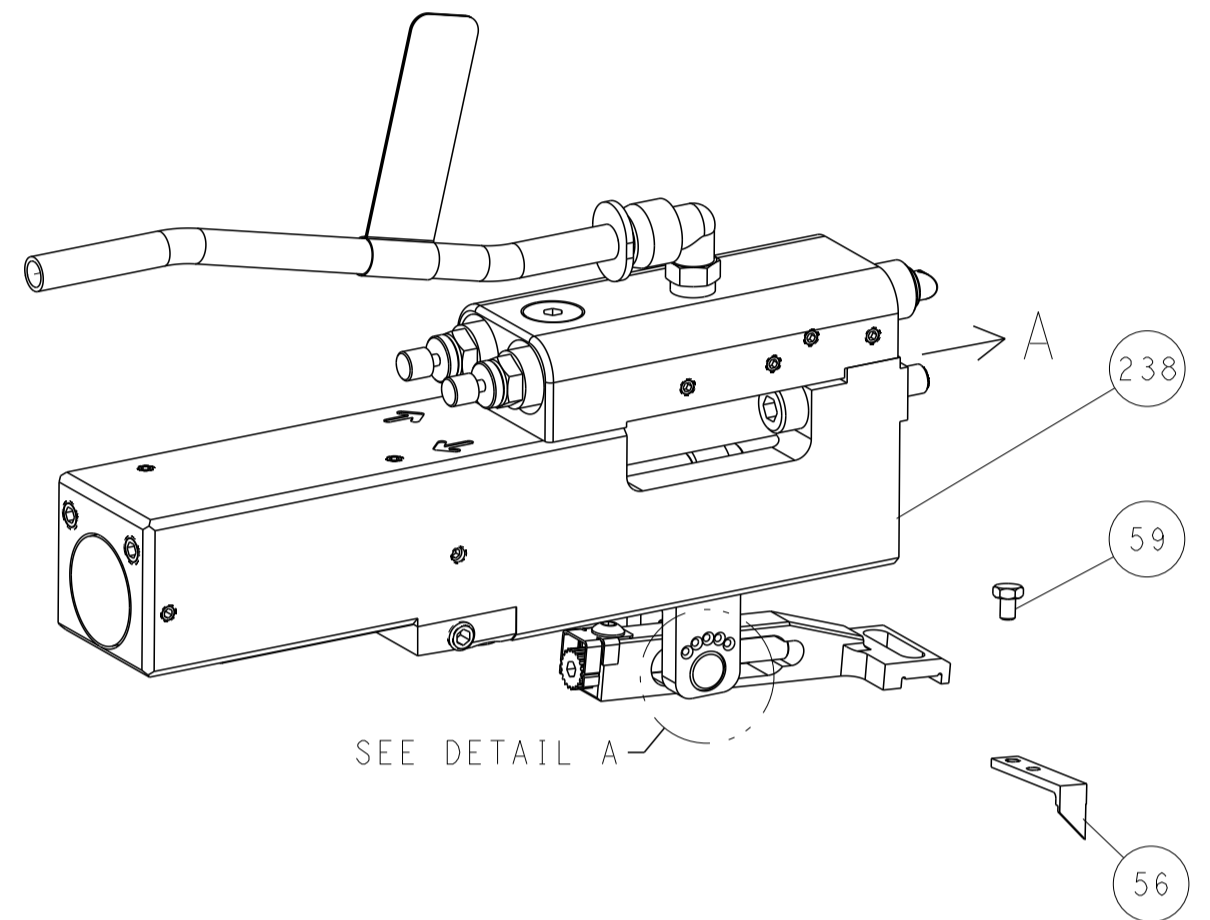

FEED SPRING SETTING POSITION (SHOWN FROM REAR SIDE)

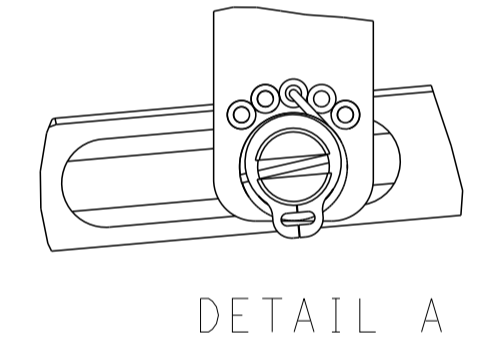

DETAIL A

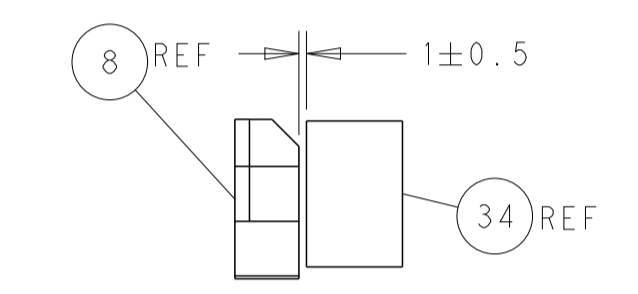
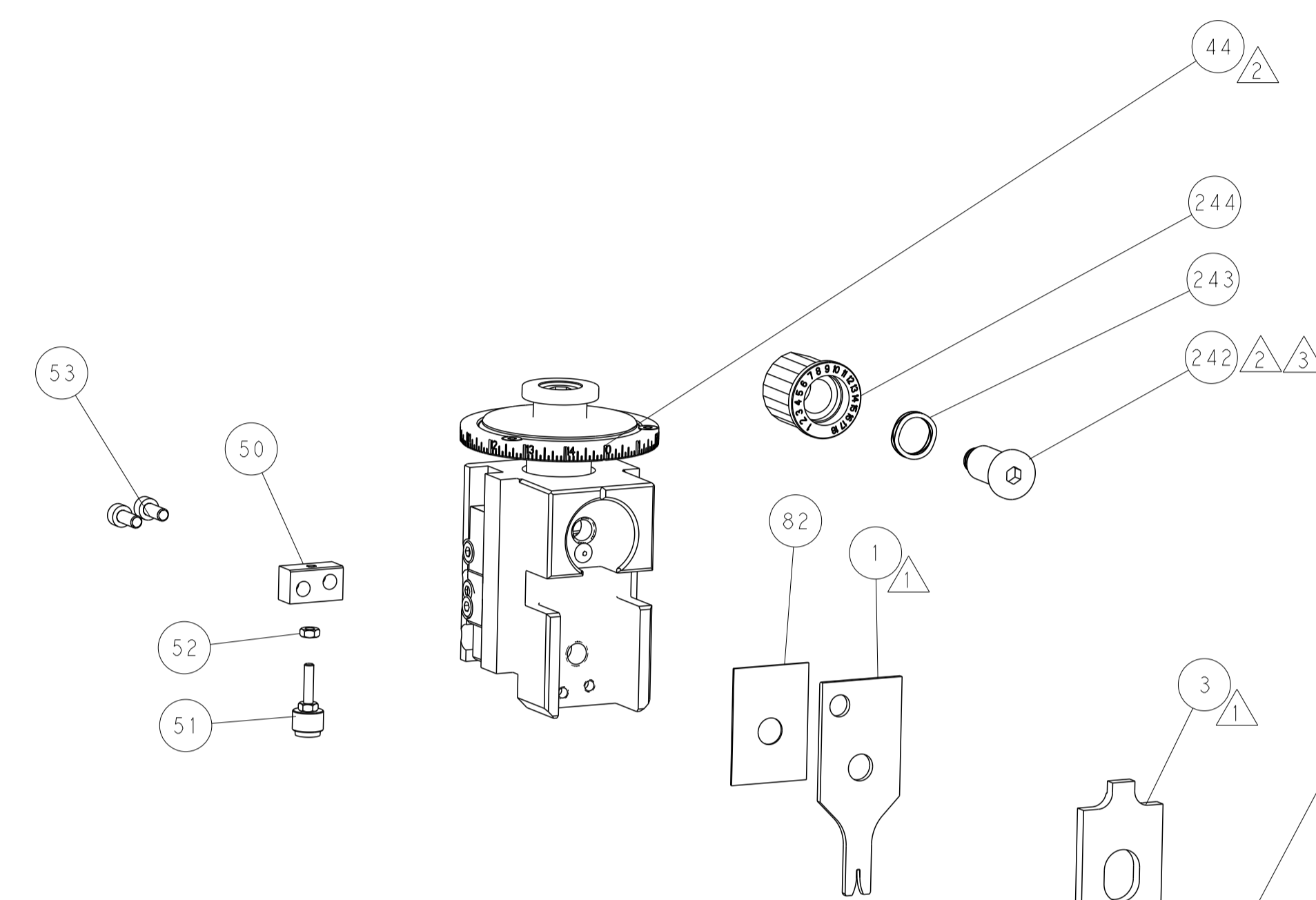

TERMINAL SUPPORT LOCATION

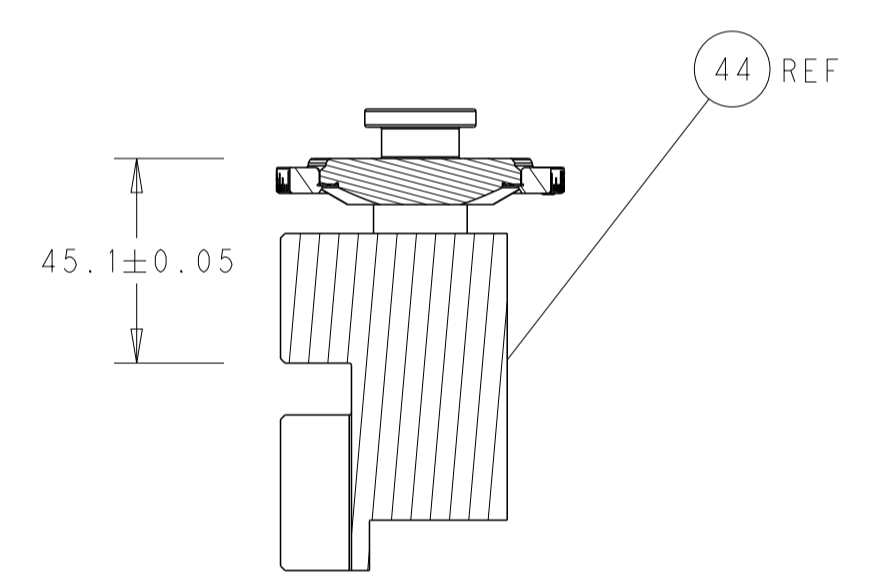

RAM SET-UP

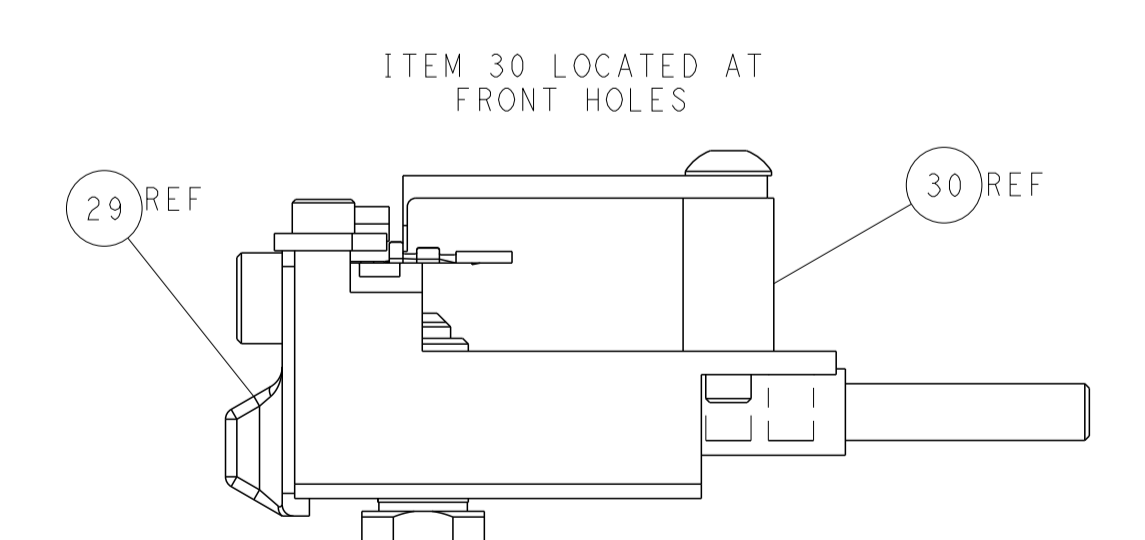
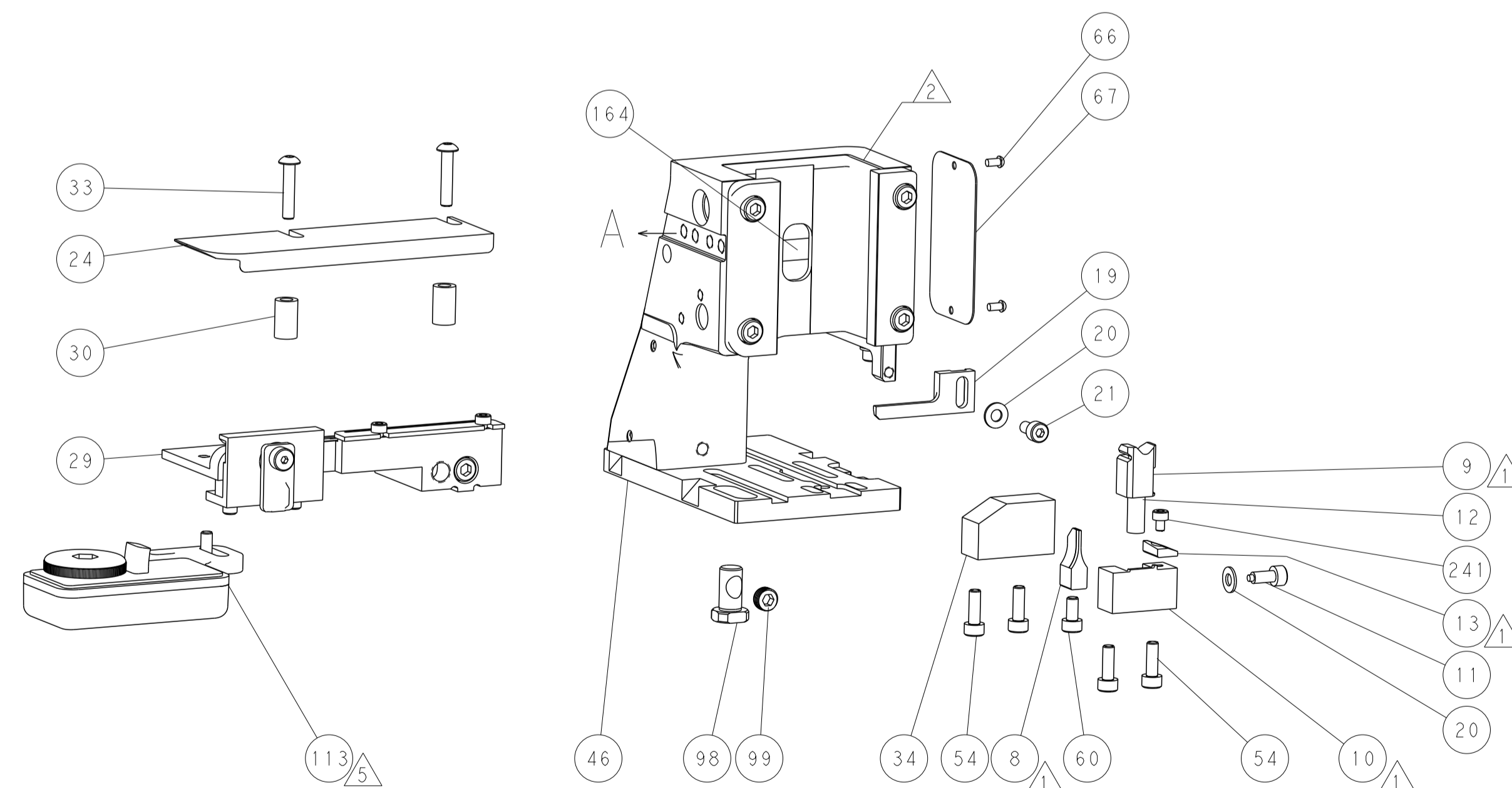

ITEM 30 LOCATED AT FRONT HOLES

CAM POSITIONS

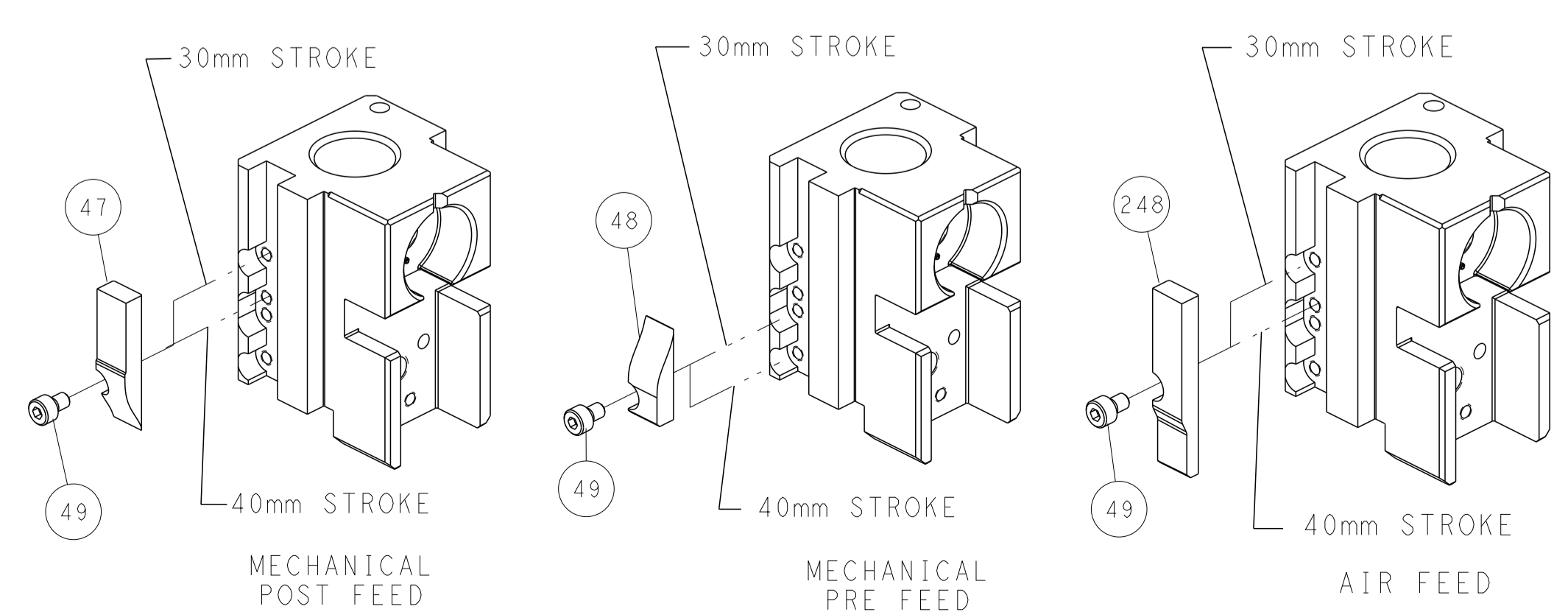

ATLANTIC VERSION
 Shown on sheets 1 of 4 & 2 of 4
 (Pacific version shown on sheets 3 of 4 & 4 of 4)

DIMENSIONS:		TOLERANCES UNLESS OTHERWISE SPECIFIED:		DWG: J.HOU 1AUG2014		CHK: Y.YIN 1AUG2014		NAME: Ocean Side Feed Applicator	
mm	0 PLC ±	1 PLC ±	2 PLC ±	3 PLC ±	4 PLC ±	APVD: J.GUO 1AUG2014	PRODUCT SPEC	APPLICATION SPEC	SIZE: A1
MATERIAL:	FINISH:	WEIGHT:	CAGE CODE:	DRAWING NO:	RESTRICTED TO:	Customer Accessible Production Drawing		SCALE: 1:2	SHEET 2 OF 4
				©=2266422				REV C	

PART NUMBER	REVISION	DESCRIPTION	FEED TYPE
2-2266422-1	C	FINE CRIMP HEIGHT ADJUST	MECHANICAL
2-2266422-2	C	FINE CRIMP HEIGHT ADJUST	PNEUMATIC
7-2266422-7	A	CRIMP TOOLING KIT	-

PACIFIC VERSION TERMINATOR
INTERFACE ADAPTER



APPLICATOR DATA		
CRIMP	SIZE	TYPE
WIRE	1.00 mm [.039]	F
INSUL	1.07 mm [.042]	O
APPLICATOR INSTRUCTIONS 408-35042		

TERMINAL DATA: MOLEX TERMINAL		MOLEX CRIMP SPECIFICATION	
TERMINAL NAME: CTX50 RECEPTACLE-UNSEALED			
WIRE STRIP LENGTH		INSULATION DIAMETER RANGE	
2.60-3.00 mm [.102-.118 IN]		Ø0.95-1.20 mm [.037-.047 IN]	
TERMINAL APPLICATION SPECIFICATION	63901-4900 Rev C		
TERMINALS APPLIED			
TE TERMINAL	MOLEX TERMINAL	TE TERMINAL	MOLEX TERMINAL
2113536-1	560023-0421		

WIRE SIZE	CRIMP HEIGHT mm [INCH]	CRIMP HEIGHT REFERENCE SETTING
0.35mm2	0.72 +/- 0.03 [.028 +/- .001]	5.6
0.22mm2	0.69 +/- 0.03 [.027 +/- .001]	5.7

- RECOMMENDED SPARE PARTS
- REFER TO SUPPLIED INSTRUCTION SHEET FOR CLEANING, LUBRICATION AND STORAGE OF APPLICATOR.
- APPLY PART NUMBER 2-23419-6 LOCTITE TO THREADS OF ITEM 242.
- CRIMP HEIGHT REFERENCE SETTING WAS THE SETTING USED WHEN THE APPLICATOR WAS QUALIFIED AT THE FACTORY. ADJUSTMENT MAY BE NECESSARY WHEN RUNNING APPLICATOR IN THE FIELD.
- TERMINAL LUBRICANT IS RECOMMENDED.
- 6. UNLESS SPECIFIED OTHERWISE TORQUE VALUES SHALL BE USED PER DOCUMENT, 101-35000.

***WARNING**
ON INSTALLATION, SET WIRE DISC TO CRIMP HEIGHT REFERENCE SETTING FOR LARGEST WIRE SIZE. CRIMP HEIGHT REFERENCE SETTINGS GREATER THAN THE VALUE SHOWN MAY CAUSE DAMAGE TO THE CRIMP TOOLING. REFER TO THE INSTRUCTION SHEET FOR PROPER SETUP AND ADJUSTMENTS.

LOC	DIST	REV	DATE	BY	APPV
		1			
		2			
		3			
		4			

QTY	REF	REF	DESCRIPTION	ITEM NO
-	1	1	2119082-5 CAM, SNAIL, INSULATION ADJUSTMENT	244
-	1	1	2079764-1 WASHER, WAVE SPRING, CREST-TO-CREST	243
-	1	1	2119083-1 RETAINER, INSULATION DIAL	242
-	1	1	7-18023-7 SCR, SKT HD CAP M3 X 4.0	241
-	-	1	2119580-1 MECHANICAL FEED ASSEMBLY	239
-	1	-	2844940-1 AIR FEED MODULE	238
-	REF	REF	994970-2 COUNTER, MAGNETIC	164
-	1	-	2119641-2 FEED CAM, AIR FEED	151
-	1	1	2168083-8 SCR, SKT HD CAP, RoHS, M4 X 16	144
-	4	4	2168083-9 SCR, SKT HD CAP, RoHS, M4 X 20	143
-	-	1	2119653-2 FEED CAM, POST FEED	142
-	1	1	1-1803583-0 APPLICATOR BASIC ASSEMBLY, SF	141
-	1	1	1803516-1 RAM ASSEMBLY, SF PACIFIC	140
-	1	1	2119955-1 ASSY, LUBRICATOR, SIDE FEED	113
-	1	1	2844908-1 SCREW, LOCKING	99
-	1	1	2844907-1 POST, LOCKING	98
-	1	1	455888-5 SPACER, CRIMPER	82
-	1	1	5-547505-2 SPRING, COMPRESSION	77
-	1	1	854769-4 HOLDER, INS	74
-	1	1	1803607-3 DOCUMENTATION PACKAGE	71
-	1	1	2119740-1 TAG, IDENTIFICATION	67
-	2	2	2168078-1 SCREW, DRIVE, RH, RoHS, 2 x .188	66
-	1	1	5-18022-5 SCR, HEX HD CAP, M4 X 6.0	59
-	1	1	21028-2 PIN, SLOTTED SPRING .062 X .250	58
-	1	1	1338685-1 PAWL, FEED	56
-	2	2	1-2168083-0 SCR, SKT HD CAP, RoHS, M4 X 10	53
-	1	1	5018030-1 NUT, HEX, REG, RoHS, M3	52
-	1	1	811242-5 BUMPER, HOLD DOWN	51
-	1	1	690753-2 SPACER, TONKER	50
-	1	2	18023-9 SCR, SKT HD CAP M4 X 6.0	49
-	-	1	2119652-1 FEED CAM, PRE FEED	48
-	1	1	1803602-1 SCR, BHSC, RoHS (M8 X 25)	41
-	1	1	1752356-3 SUPPORT, TERMINAL	34
-	2	2	2079383-5 SCR, BHSC, RoHS (M4 X 20)	33
-	2	2	2-2844962-3 SPACER, CYLINDRICAL, STRIP GUIDE	30
-	1	1	2844992-1 ASSEMBLY, STRIP GUIDE	29
-	1	1	455888-3 SPACER, CRIMPER	28
-	1	1	1320928-2 STRIP GUIDE	24
-	1	1	2168083-2 SCR, SKT HD CAP, RoHS, M4 X 8.0	21
-	2	2	1-18028-2 WASHER, FLAT, REG M4	20
-	1	1	2119533-1 STRIPPER, SIDE FEED	19
-	1	1	2119806-1 INSERT, SHEAR	13
-	1	1	3-22280-3 SPRING, COMPRESSION	12
-	1	1	1-356885-4 STOP, SHEAR	11
-	1	1	2119805-1 SHEAR HOLDER, FRONT	10
-	1	1	1803095-6 FLOATING SHEAR, FRONT	9
-	1	1	7-1633932-2 ANVIL, COMBINATION	8
-	-	-	-	7
-	-	-	-	6
-	1	1	2119780-6 DEPRESSOR, SHEAR	5
-	1	1	4-238011-1 BLOCK, CRIMPER SPACER	4
-	1	1	1-1633966-8 CRIMPER, INSULATION O	3
-	-	-	-	2
-	1	1	9-1633609-8 CRIMPER, WIRE	1

PACIFIC VERSION
Shown on sheets 3 of 4 & 4 of 4
(Atlantic version shown on sheets 1 of 4 & 2 of 4)

<small>THIS DRAWING IS UNPUBLISHED. IT IS THE PROPERTY OF STE AND IS NOT TO BE REPRODUCED OR TRANSMITTED IN ANY FORM OR BY ANY MEANS, ELECTRONIC OR MECHANICAL, WITHOUT THE WRITTEN PERMISSION OF STE. ANY UNAUTHORIZED REPRODUCTION OR TRANSMISSION IS STRICTLY PROHIBITED. ALL RIGHTS RESERVED.</small>		DWN J.HOU 1AUG2014 CHK Y.YIN 1AUG2014 APVD U.GUO 1AUG2014	
DIMENSIONS: mm 		TOLERANCES UNLESS OTHERWISE SPECIFIED: 0 PLC ± 1 PLC ± 2 PLC ± 3 PLC ± 4 PLC ± ANGLES ± FINISH ±	NAME Ocean Side Feed Applicator PRODUCT SPEC - APPLICATION SPEC - SIZE CAGE CODE DRAWING NO WEIGHT - SCALE 1:2 SHEET 3 OF 4 REV C
MATERIAL - FINISH -		WEIGHT - SCALE 1:2 SHEET 3 OF 4 REV C	RESTRICTED TO - Customer Accessible Production Drawing

LOC	DIST	REVISIONS			
P	LTN	DESCRIPTION	DATE	DMN	APVD
rev_sym_1	1866	8H6E111		rev_defect	dmn_bppr_1
rev_sym_2	rev_desc_2			rev_defect	dmn_bppr_2
rev_sym_3	rev_desc_3			rev_defect	dmn_bppr_3
rev_sym_4	rev_desc_4			rev_defect	dmn_bppr_4

FEED TYPE MECHANICAL

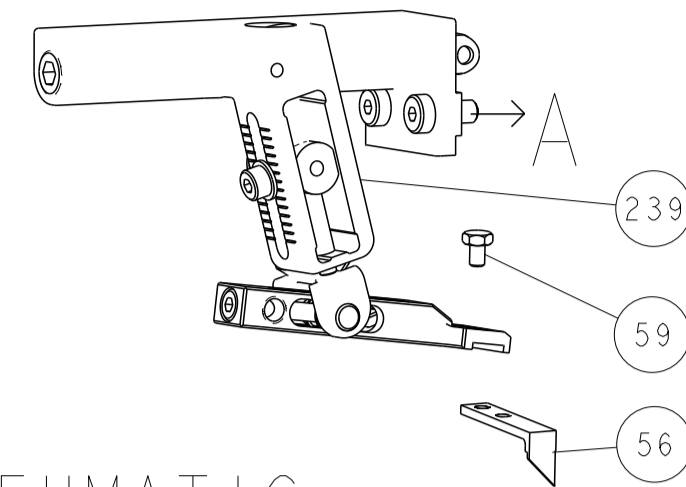

PNEUMATIC

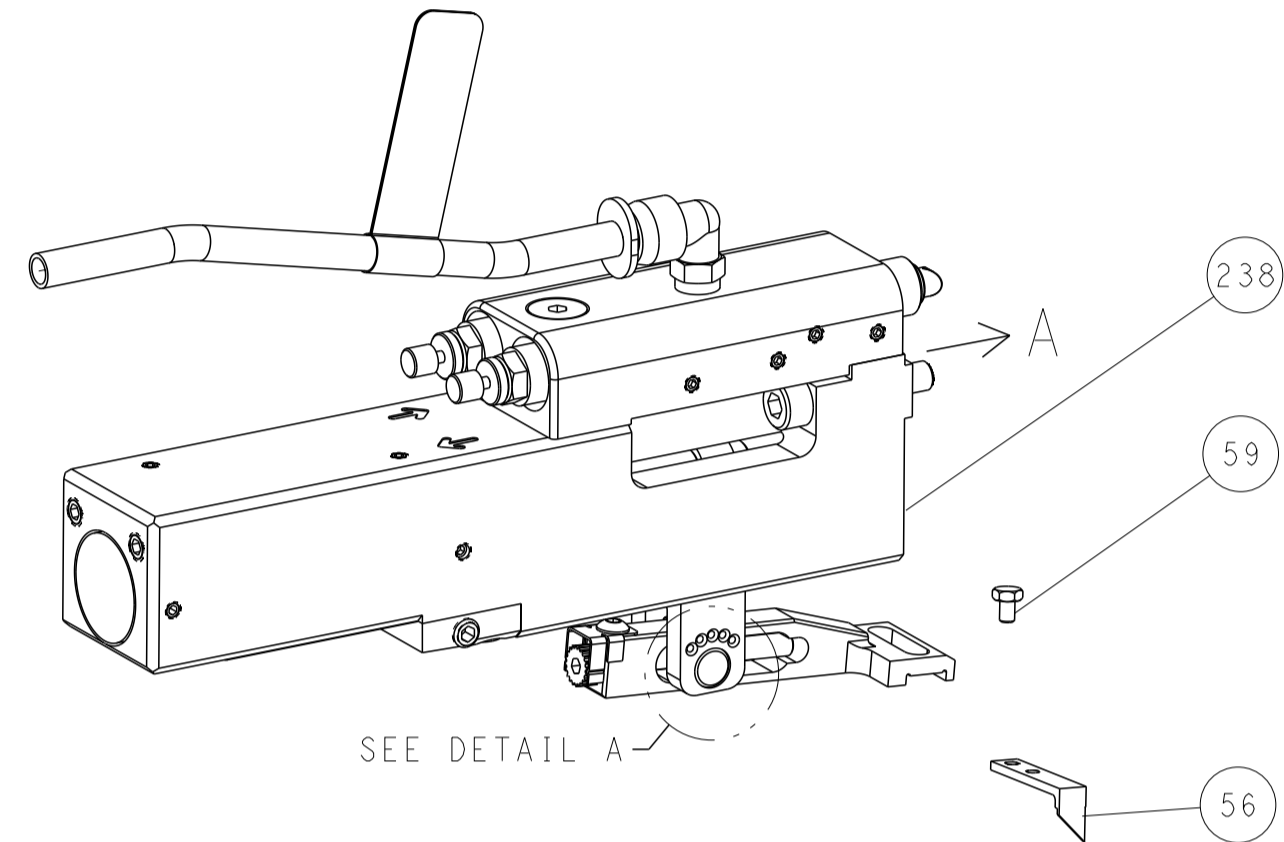

FEED SPRING SETTING POSITION (SHOWN FROM REAR SIDE)

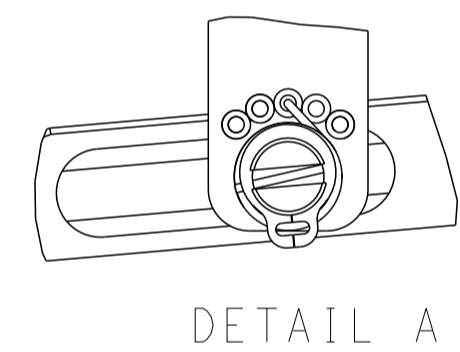

CAM POSITIONS

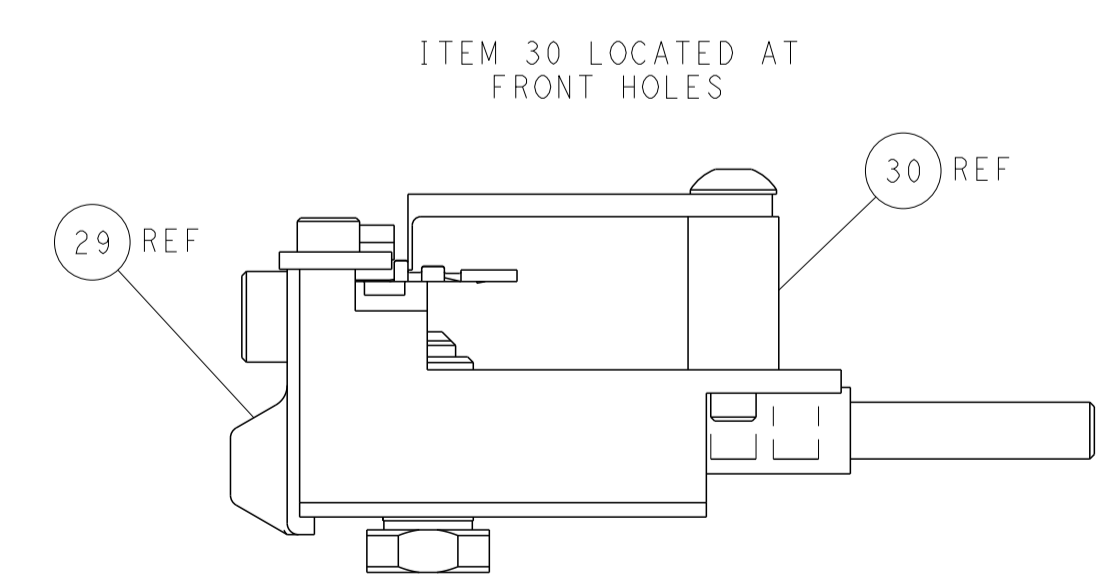
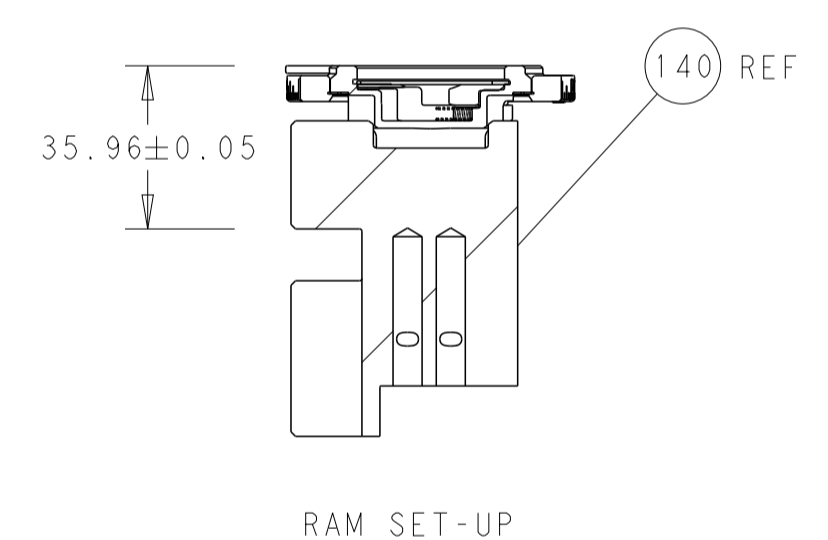
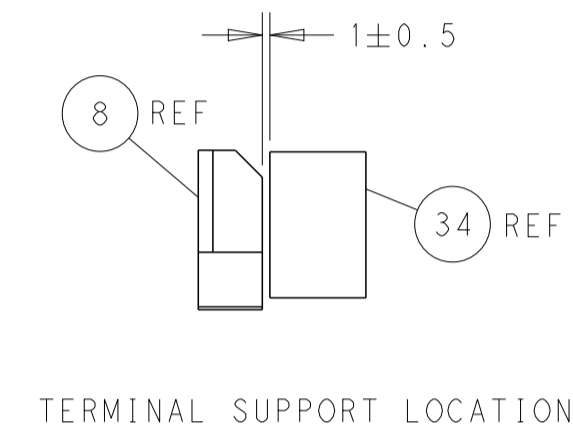
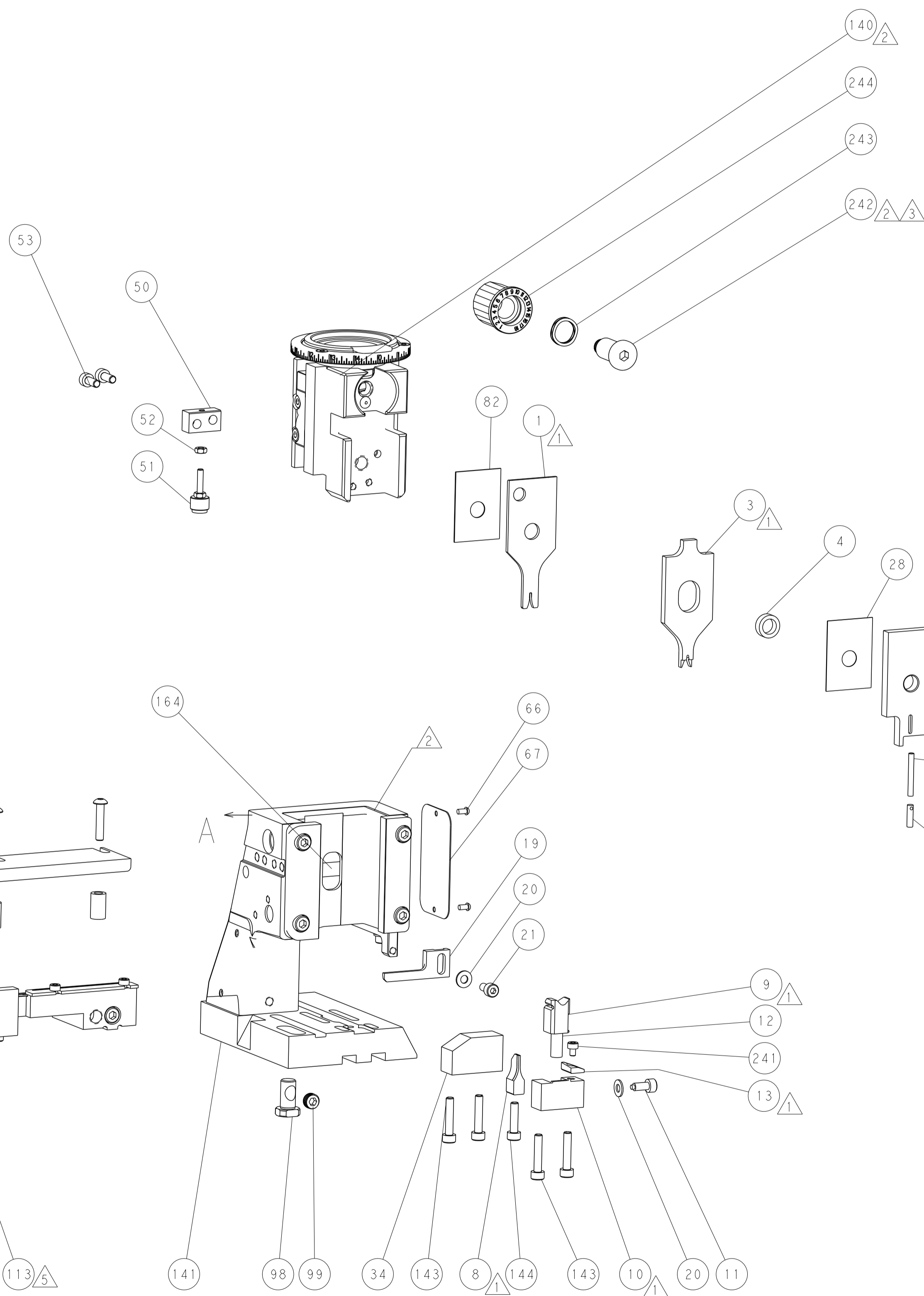
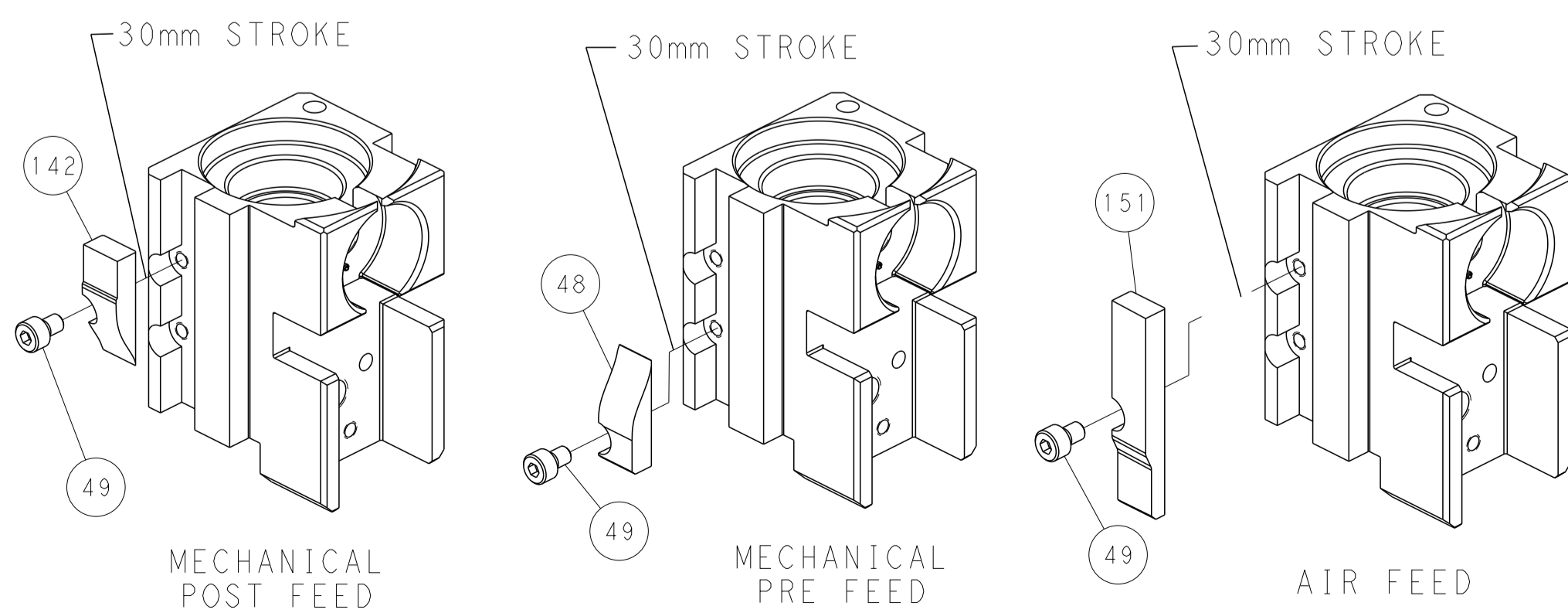

PACIFIC VERSION
 Shown on sheets 3 of 4 & 4 of 4
 (Atlantic version shown on sheets 1 of 4 & 2 of 4)

DIMENSIONS: mm 		TOLERANCES UNLESS OTHERWISE SPECIFIED: 0 PLC ± 1 PLC ± 2 PLC ± 3 PLC ± 4 PLC ± ANGLES ± FINISH ±		DWG J.HOU 1AUG2014 CHK Y.YIN 1AUG2014 APVD H.GUO 1AUG2014 PRODUCT SPEC APPLICATION SPEC NAME Ocean Side Feed Applicator SIZE CAGE CODE DRAWING NO A1 00779 C=2266422 RESTRICTED TO	
MATERIAL		WEIGHT		Customer Accessible Production Drawing	
		SCALE 1:2		SHEET 4 OF 4 REV C	