



# Evaluation Board

For XMC4000 Family

## XMC4400 Platform2Go

Kit Version 1.1

### Board User's Manual

Revision 2019-08-30

Microcontroller

**Edition 2019-08-30**

**Published by**

**Infineon Technologies AG**

**81726 Munich, Germany**

**© 2019 Infineon Technologies AG**

**All Rights Reserved.**

#### **Legal Disclaimer**

The information given in this document shall in no event be regarded as a guarantee of conditions or characteristics. With respect to any examples or hints given herein, any typical values stated herein and/or any information regarding the application of the device, Infineon Technologies hereby disclaims any and all warranties and liabilities of any kind, including without limitation, warranties of non-infringement of intellectual property rights of any third party.

#### **Information**

For further information on technology, delivery terms and conditions and prices, please contact the nearest Infineon Technologies Office ([www.infineon.com](http://www.infineon.com)).

#### **Warnings**

Due to technical requirements, components may contain dangerous substances. For information on the types in question, please contact the nearest Infineon Technologies Office.

Infineon Technologies components may be used in life-support devices or systems only with the express written approval of Infineon Technologies, if a failure of such components can reasonably be expected to cause the failure of that life-support device or system or to affect the safety or effectiveness of that device or system. Life support devices or systems are intended to be implanted in the human body or to support and/or maintain and sustain and/or protect human life. If they fail, it is reasonable to assume that the health of the user or other persons may be endangered.

---

**Revision History**

<b>Page or Item</b>	<b>Subjects (major changes since previous revision)</b>
Revision 2019-08-30	Initial Version

**Trademarks of Infineon Technologies AG**

AURIX™, C166™, CanPAK™, CIPOS™, CIPURSE™, EconoPACK™, CoolMOS™, CoolSET™, CORECONTROL™, CROSSAVE™, DAVE™, EasyPIM™, EconoBRIDGE™, EconoDUAL™, EconoPIM™, EiceDRIVER™, eupec™, FCOS™, HITFET™, HybridPACK™, I<sup>2</sup>RF™, ISOFACE™, IsoPACK™, MIPAQ™, ModSTACK™, my-d™, NovalithIC™, OptiMOS™, ORIGA™, PRIMARION™, PrimePACK™, PrimeSTACK™, PRO-SIL™, PROFET™, RASIC™, ReverSave™, SatRIC™, SIEGET™, SINDRION™, SIPMOS™, SmartLEWIS™, SOLID FLASH™, TEMPFET™, thinQ!™, TRENCHSTOP™, TriCore™.

**Other Trademarks**

Advance Design System™ (ADS) of Agilent Technologies, AMBA™, ARM™, MULTI-ICE™, KEIL™, PRIMECELL™, REALVIEW™, THUMB™, μVision™ of ARM Limited, UK. AUTOSAR™ is licensed by AUTOSAR development partnership. Bluetooth™ of Bluetooth SIG Inc. CAT-iq™ of DECT Forum. COLOSSUS™, FirstGPS™ of Trimble Navigation Ltd. EMV™ of EMVCo, LLC (Visa Holdings Inc.). EPCOS™ of Epcos AG. FLEXGO™ of Microsoft Corporation. FlexRay™ is licensed by FlexRay Consortium. HYPERTERMINAL™ of Hilgraeve Incorporated. IEC™ of Commission Electrotechnique Internationale. IrDA™ of Infrared Data Association Corporation. ISO™ of INTERNATIONAL ORGANIZATION FOR STANDARDIZATION. MATLAB™ of MathWorks, Inc. MAXIM™ of Maxim Integrated Products, Inc. MICROTEC™, NUCLEUS™ of Mentor Graphics Corporation. Mifare™ of NXP. MIPI™ of MIPI Alliance, Inc. MIPS™ of MIPS Technologies, Inc., USA. muRata™ of MURATA MANUFACTURING CO., MICROWAVE OFFICE™ (MWO) of Applied Wave Research Inc., OmniVision™ of OmniVision Technologies, Inc. Openwave™ Openwave Systems Inc. RED HAT™ Red Hat, Inc. RFMD™ RF Micro Devices, Inc. SIRIUS™ of Sirius Satellite Radio Inc. SOLARIS™ of Sun Microsystems, Inc. SPANSION™ of Spansion LLC Ltd. Symbian™ of Symbian Software Limited. TAIYO YUDEN™ of Taiyo Yuden Co. TEAKLITE™ of CEVA, Inc. TEKTRONIX™ of Tektronix Inc. TOKO™ of TOKO KABUSHIKI KAISHA TA. UNIX™ of X/Open Company Limited. VERILOG™, PALLADIUM™ of Cadence Design Systems, Inc. VLYNQ™ of Texas Instruments Incorporated. VXWORKS™, WIND RIVER™ of WIND RIVER SYSTEMS, INC. ZETEX™ of Diodes Zetex Limited.

Last Trademarks Update 2011-02-24

EtherCAT® is registered trademark and patented technology, licensed by Beckhoff Automation GmbH, Germany.

## Table of Contents

<b>1</b>	<b>Introduction .....</b>	<b>6</b>
1.1	Key Features.....	7
1.2	Block Diagram .....	8
<b>2</b>	<b>Hardware Description .....</b>	<b>8</b>
2.1	Power Supply .....	11
2.2	Pin Header for Microbus and Shield2Go Connector 1 and 2 .....	13
2.3	Solderable 0 Ohm Pin Bridges.....	14
2.4	Arduino Compatible Connector .....	15
2.5	User Push Buttons and User LEDs.....	16
2.6	On-board Debug Probe .....	16
2.7	UART Communication for XMC4200.....	16
2.8	Cortex™ Debug Connector (10-pin) .....	17
2.9	Reset .....	17
2.10	CAN Transceiver .....	17
2.11	Serial Flash Memory.....	18
2.12	Ethernet .....	18
2.13	Boot Option.....	19
<b>3</b>	<b>Production Data.....</b>	<b>19</b>
3.1	Schematics .....	19
3.2	List of Material .....	25

## List of Figures

Figure 1	Block Diagram of the XMC4400 Platform2Go Series-V1 .....	8
Figure 2	XMC4400 Platform2Go 3.3V .....	9
Figure 3	XMC4400 Platform2Go 5V .....	9
Figure 4	XMC4400 Platform2Go 3.3V Lite .....	10
Figure 5	XMC4400 Platform2Go 5V Lite .....	10
Figure 6	Power Supply Concept .....	11
Figure 7	Signal mapping of the pin headers X1 and X2 .....	12
Figure 8	Signal mapping of the pin headers for Microbus and Shield2Go Connector 1 and 2.....	13
Figure 9	Mapping of Arduino Functions to XMC Pin Functions.....	15
Figure 10	Connectors Schematic: Pin header, Pin Bridges, Level Shifter, Microbus, Shield2Go.....	20
Figure 11	XMC_4400_Debug Schematic: OBD Probe, Ethernet, Quad-SPI Memory .....	21

**Table of Contents**

Figure 12 XMC4400 Schematic: USB connector, Microcontroller pins and power, .....22  
 Figure 13 ICs and Power Schematic: Can Transceiver, RTC Battery, Power .....23  
 Figure 14 Geometry .....24

**List of Tables**

Table 1 Kit Specification.....6  
 Table 2 Kit Features of Assembly Versions .....7  
 Table 3 Signal mapping of the 0 Ohm Pin Bridges.....14  
 Table 4 XMC4400 Pin Mapping for User LEDs .....16  
 Table 5 XMC4400 Pin Mapping for User Push Buttons and Potentiometer .....16  
 Table 6 XMC4400 Pins Mapping for Debugging and UART-Communication.....16  
 Table 7 Pin Assignment of the Cortex™ Debug Connector (X102) .....17  
 Table 8 CAN Signals and XMC4400 Pin Mapping.....17  
 Table 9 XMC4400 Pins Mapping for Serial Flash Memory.....18  
 Table 10 XMC4400 Pins used for Ethernet .....18  
 Table 11 Boot Mode Selection with external Pull Resistors .....19  
 Table 12 List of Material .....25

## 1 Introduction

This document describes the features and hardware details of the XMC4400 Platform2Go Series-V1.1 equipped with an ARM® Cortex®-M4 based XMC™ Microcontroller from Infineon Technologies AG.

It can be used with a wide range of development tools including Infineon's free of charge Eclipse based IDE DAVE. The XMC4400 Platform2Go Series-V1.1 are designed to evaluate the capabilities of the XMC4400 Microcontroller. Table 1 shows its specification.

**Table 1 Kit Specification**

Processor	Infineon's ARM® Cortex®-M4 XMC4400 Microcontroller in PG-LQFP-100 package (order number XMC4400-F100F512 BA)
Flash Memory	512 kB Flash
Data Memory	80 kB
Dimensions	66 x 136 mm
Clock Crystals	<ul style="list-style-type: none"> <li>• 12 MHz and 32.768 kHz crystal for CPU</li> <li>• 25 MHz crystal for Ethernet Phy</li> </ul>
Power	<ul style="list-style-type: none"> <li>• 5V external powering</li> <li>• Micro-AB USB Connector interface or</li> <li>• On-Board Debugger USB interface</li> </ul>
Connectors	<ul style="list-style-type: none"> <li>• Arduino compatible connectors for 3.3V/5V</li> <li>• Two Shield2Go connectors</li> <li>• All relevant XMC™ pins available on expansion pads (X1, X2)</li> <li>• mikroBUS™ connector</li> <li>• Ethernet interface via RJ45 jack</li> <li>• microUSB</li> <li>• Serial Wire Debug interface (2x5, 50 mil pitch) to XMC™ (on board debugger can be overridden by externally connected debugger)</li> </ul>
Debugger	On-Board J-Link Debug Probe via USB supporting <ul style="list-style-type: none"> <li>• Serial Wire Debug (SWD)</li> <li>• UART-to-USB bridge (virtual COM)</li> </ul>
Others	<ul style="list-style-type: none"> <li>• On-board debug probe, based on XMC4200 Microcontroller</li> <li>• Ethernet Phy</li> <li>• CAN transceiver connected to X3</li> <li>• 32 Mbit Quad-SPI Flash Memory</li> <li>• 2 user push-buttons, 2 user LEDs</li> <li>• Reset push-button</li> <li>• Potentiometer (10kOhm) for variable analog input</li> </ul>

The XMC4400 Platform2Go Series-V1.1 are available in four different assembly versions differentiating in features:

- XMC4400 Platform2Go for 3.3V Shields
- XMC4400 Platform2Go for 5V Shields
- XMC4400 Platform2Go Lite for 3.3V Shields
- XMC4400 Platform2Go Lite for 5V Shields

The **XMC4400 Platform2Go** features an Ethernet-enabled communication option. You can control the XMC4400 Platform2Go via the web browser on your PC.

Additional voltage level shifters and Arduino connection header on the XMC4400 Platform2Go allow the usage of **Arduino shields with 3.3V or 5V** logic level.

The Ethernet-communication is not supported by the **XMC4400 Platform2Go Lite Kit**, because some components e.g. for Ethernet are not assembled.

All boards are marked with “Platform2Go XMC4400-V1.1” and can be distinguished by the assembled devices (see pictures in chapter 2). These boards are neither cost nor size optimized and do not serve as a reference design.

## 1.1 Key Features

Table 2 summarizes the features of the different assembly versions of the XMC4400 Platform2Go Series-V1.1.

**Table 2 Kit Features of Assembly Versions**

Feature	XMC4400 Platform2Go 3.3V	XMC4400 Platform2Go 3.3V Lite	XMC4400 Platform2Go 5V	XMC4400 Platform2Go 5V Lite
XMC4400 Microcontroller	✓	✓	✓	✓
On-board Debug Probe with USB interface supporting SWD + SWO	✓	✓	✓	✓
Virtual COM Port via Debug Probe	✓	✓	✓	✓
2 x User Push-Buttons and 2 x User LED and 1 x Reset Push-Button 1 x Potentiometer	✓	✓	✓	✓
Voltage Regulator 5 V -> 3.3 V	✓	✓	✓	✓
USB (Micro USB Plug)	✓	✓	✓	✓
12 MHz Crystal	✓	✓	✓	✓
32.768 kHz RTC Crystal	✓		✓	
Arduino compatible connector 3.3 V / 5 V Arduino shields	✓	✓	✓	✓
0 Ohm Bridges Array for 3.3 V Arduino shields	✓	✓		
Voltage level shifter for 5 V Arduino			✓	✓
Ethernet PHY and RJ45 Jack	✓		✓	
32 Mbit Quad-SPI Flash Memory	✓		✓	
CAN Transceiver	✓		✓	

## 1.2 Block Diagram

The block diagram in Figure 1 shows the main components of the XMC4400 Platform2Go and their interconnections. There are following main building blocks:

- XMC4400 Microcontroller in a LQFP100 package
- On-board USB debug probe based on XMC4200 for SWD, SWV and Virtual COM Port support
- Ethernet Phy with RJ45 Plug
- Two 40-pin header X1 and X2
- Connection Header for Arduino
- mikroBUS™ connector
- Two Infineon Shield2Go connectors (at the bottom of the board)
- Potentiometer (10kOhm)
- On-board power generation
- 2 User Push-Buttons, 2 User LEDs, Reset Push-Button
- Micro-AB USB Plug
- CAN Transceiver connected to X3 Pinheader
- 32 Mbit Quad SPI Flash

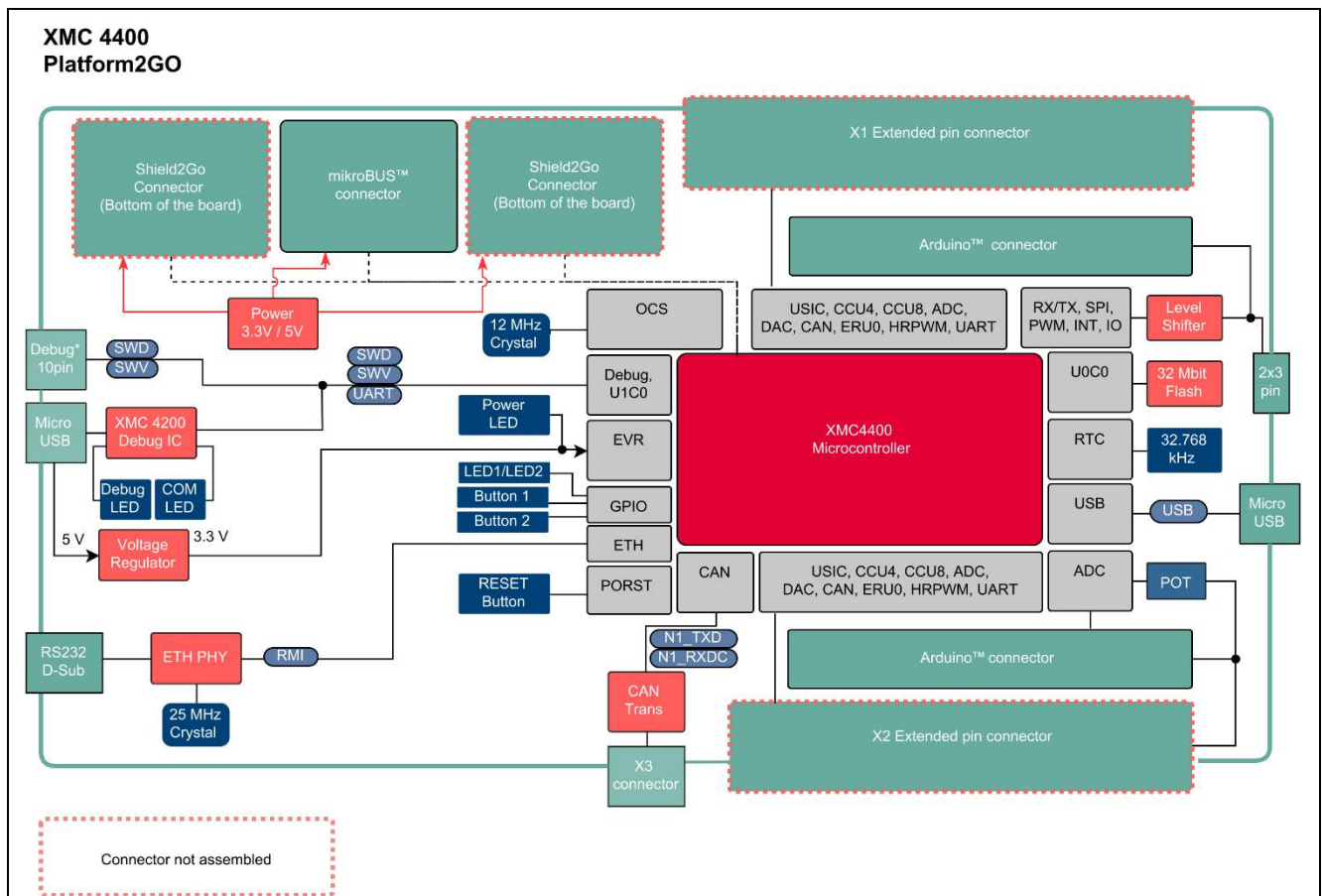

Figure 1 Block Diagram of the XMC4400 Platform2Go Series-V1

## 2 Hardware Description

The following chapters give a detailed description of the board hardware and how it can be used. The different assembly versions of the kits series are shown in Figure 2, Figure 3, Figure 4 and Figure 5.





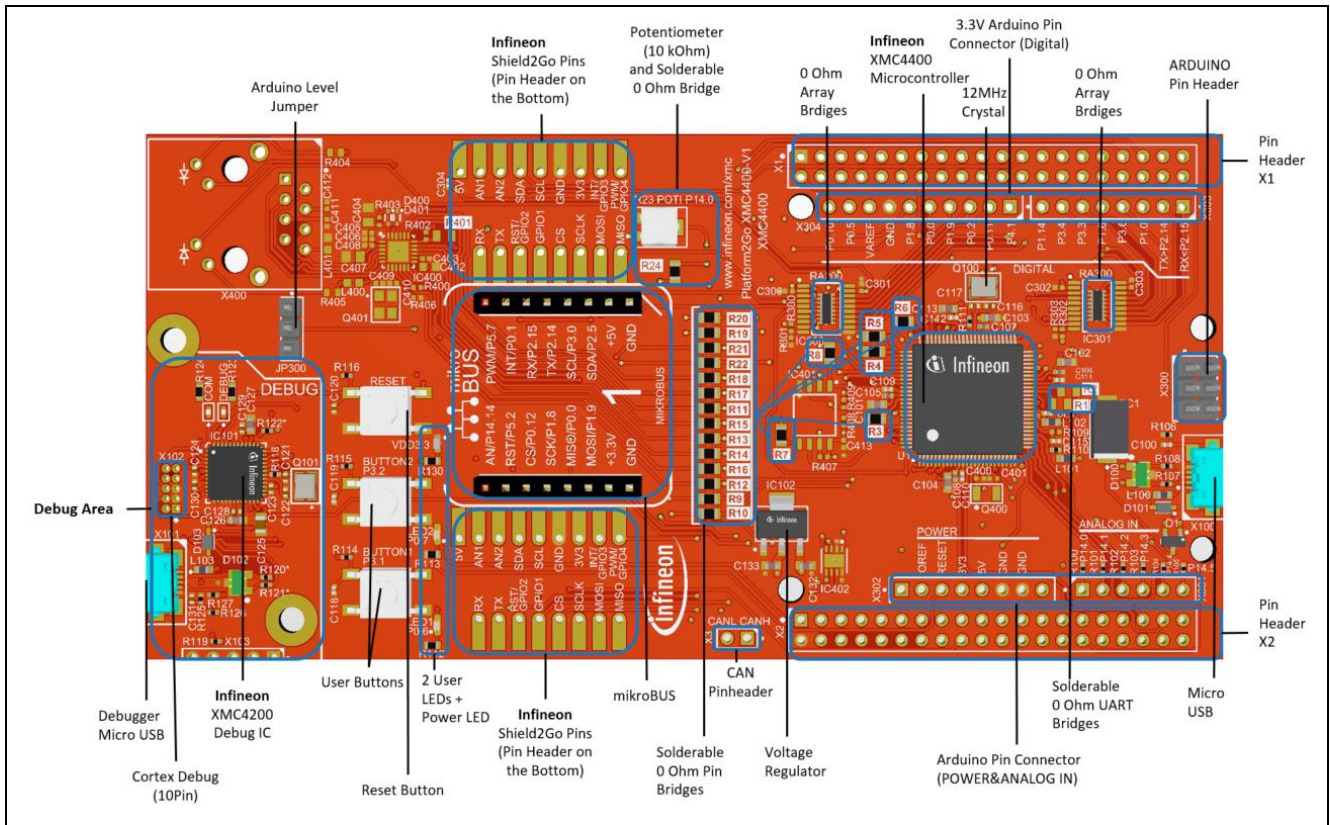

Figure 4 XMC4400 Platform2Go 3.3V Lite

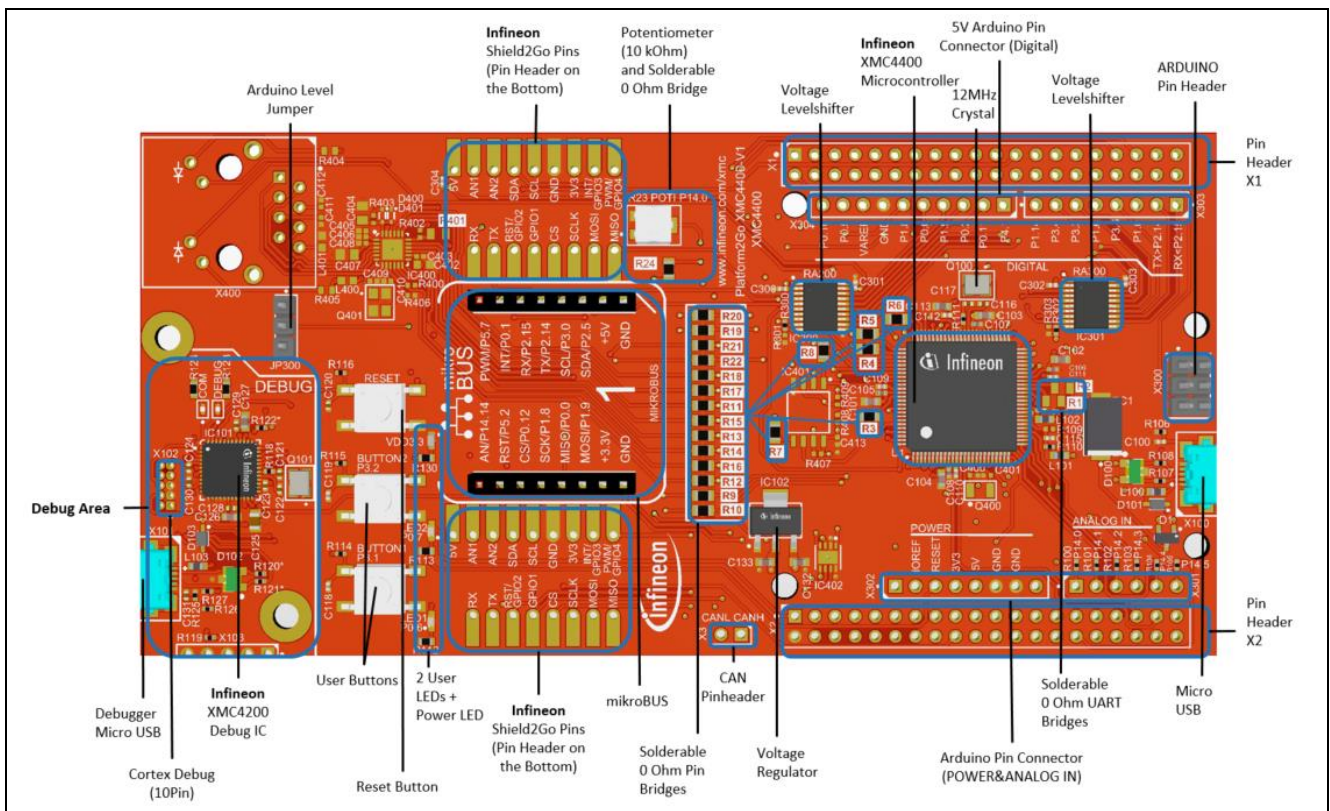

Figure 5 XMC4400 Platform2Go 5V Lite

## 2.1 Power Supply

The XMC4400 Platform2Go Series-V1.1 must be supplied by an external 5 Volt DC power supply connected to any of the micro USB plugs (X100, X101). The green Power LED (VDD3.3) indicates the presence of the generated 3.3 V supply voltage.

On-board reverse current protection diodes will ensure safe operation in case power is provided through both USB plugs at the same time. These protection diodes allows to use the on-board debug probe connected with a PC/Notebook via X101 and a second host PC/Laptop connected with the XMC4400 via X100.

If the board is powered via a USB plug, it's not recommended to apply an additional 5 Volt power supply to one of the 5 Volt power pins (VDD5, 5 V) on the pin headers X1 or X2 or the Arduino Power header, because there is no protection against reverse current into the external power supply. These power pins can be used to power an external circuit. But care must be taken not to draw more current than USB can deliver. A PC as USB host typically can deliver up to 500 mA current. If higher currents are required and in order to avoid damages on the USB host the use of an external USB power supply unit which is able to deliver higher currents than 500 mA is strongly recommended.

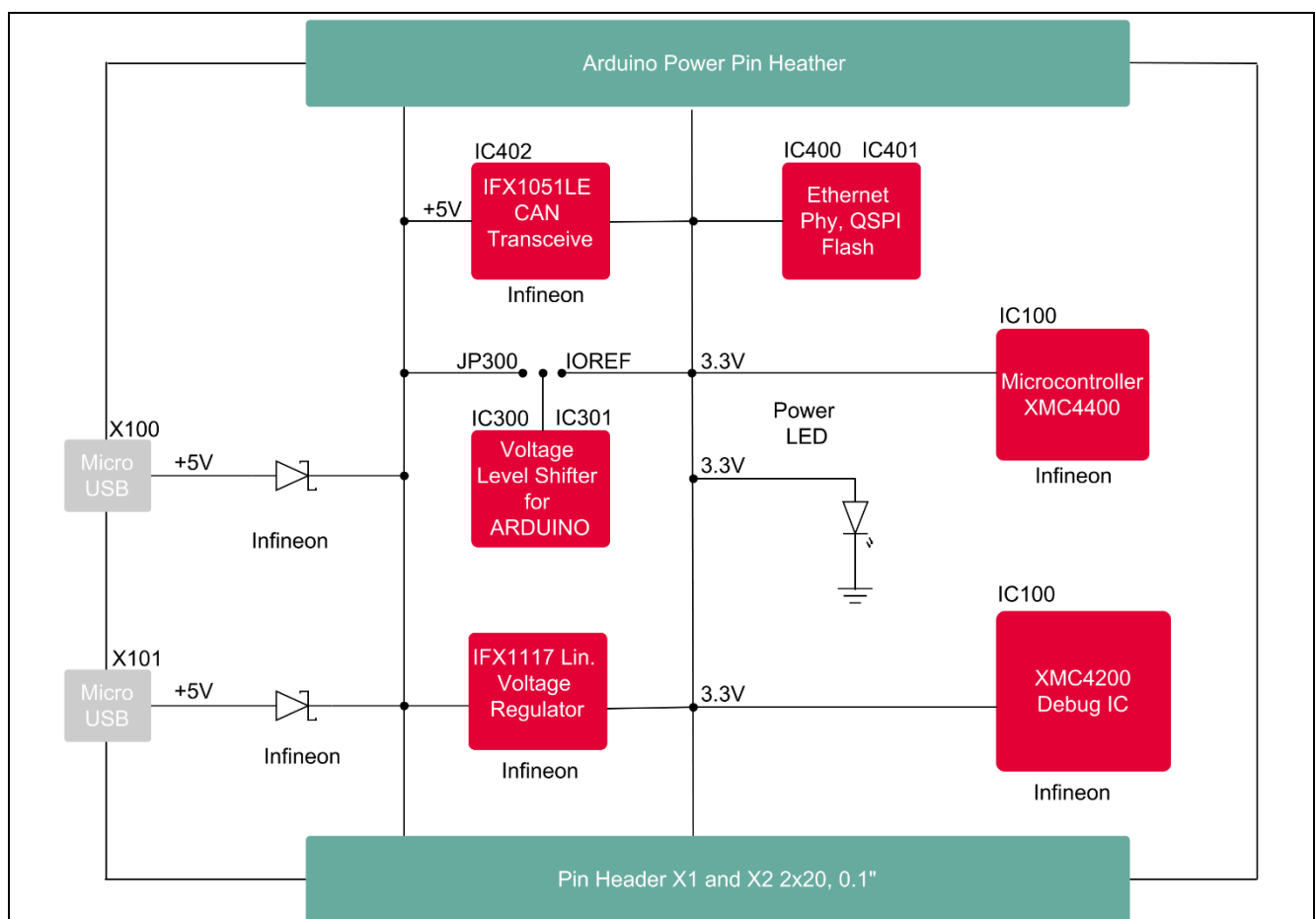

Figure 6 Power Supply Concept

## Pin Header X1 and X2

The pin headers X1 and X2 can be used to extend the evaluation board or to perform measurements on the XMC4400. Figure 7 shows the available GPIOs / signals at these pin headers. The pin table is also printed onto the bottom side of the PCB in bottom view.

Pin Header X2					Pin Header X1						
	GND	2	1	P0.7	LED2	RESET#	2	1	GND		
QSPI_CLK	P0.8*	4	3	P3.5	CS_2GO_1	UART_RX	P2.15	4	3	P2.14	UART_TX
INT_1, PWM_0	P3.6	6	5	P3.3	PWM_1	IO2	P4.1	6	5	P4.0	RST/GPIO2_2GO_2
PWM_2	P3.4	8	7	P0.11	PWM3	SPI_CS_2GO_2	P1.7	8	7	P1.6	IO_0
CS_MB	P0.12	10	9	P0.5	PC_TXD	SPI_MOSI/PWM5	P1.9	10	9	P1.8	SPI_CLK
LED1	P0.6	12	11	P0.3	INT/GPIO3_2GO_2	GPIO1_2GO_2	P1.1	12	11	P1.0	INT_0
ETH_TXEN	P0.4*	14	13	P0.1	INT	QSPI_IO2	P1.3*	14	13	P1.2*	QSPI_IO3
SPI_CS, PWM_4	P0.2	16	15	P0.10	INT/GPIO3_2GO_1	QSPI_IO0	P1.5*	16	15	P1.4*	QSPI_IO1
SPI_MISO	P0.0	18	17	P3.2*	BUTTON2	QSPI_CS	P1.11*	18	17	P1.10	RST/GPIO2_2GO_1
PWM/GPIO4_2GO_1	P0.9	20	19	P3.0	SCL, ADC_5	CAN_RX	P1.13*	20	19	P1.12*	CAN_TX
BUTTON1	P3.1*	22	21	P14.14	AN	PC_RXD	P1.15	22	21	P1.14	IO_1
SDA, ADC_4	P14.4	24	23	P14.12	AN1_2GO_2	ETH_INT	P5.1	24	23	P5.0	GPIO1_2GO_1
AN2_2GO_2	P14.13	26	25	P14.6	AN1_2GO_1	PWM	P5.7	26	25	P5.2	RST/P5.2
AN2_2GO_1	P14.7	28	27	P15.9*	ETH_CRS	ETH_MDC	P2.7*	28	27	P2.6	PWM/GPIO4_2GO_2
SCL, ADC_5	P14.5	30	29	P14.15		SWV	P2.1	30	29	P2.0*	ETH_MDIO
	P14.3	32	31	P15.2		ETH_RXD1	P2.3*	32	31	P2.2*	ETH_RXD0
ADC_3	P15.3	34	33	P14.8	DAC.OUT_0	SDA, ADC_4	P2.5	34	33	P2.4*	ETH_RXER
DAC.OUT_1	P14.9	36	35	HIB_IO_0		ETH_TXD1	P2.9*	36	35	P2.8*	ETH_TXD0
VARREF		38	37	HIB_IO_1		ETH_CLK	P15.8*	38	37	P2.10	ETH_LED
VDD3.3		40	39	#VBAT		VDD5		40	39	VDD3.3	

(Top View)

Figure 7 Signal mapping of the pin headers X1 and X2

\*Note: These pins have solderable 0 Ohm pin bridges. See section 2.3 and Table 3.



### 2.3 Solderable 0 Ohm Pin Bridges

The 0 Ohm (0805) pin bridges enable/disable the signal pins in Table 3 (enabled by default).

To disable the signals, their resistor has to be removed. The XMC4400 pins are then usable for other usages.

**Table 3 Signal mapping of the 0 Ohm Pin Bridges**

Resistor	XMC Pin	Signal
R3	P0.8	QSPI_CLK
R4	P1.2	QSPI_IO3
R5	P1.3	QSPI_IO2
R6	P1.4	QSPI_IO1
R7	P1.5	QSPI_IO0
R8	P1.11	QSPI_CS
R9	P1.12	CAN_TX
R10	P1.13	CAN_RX
R11	P0.4	ETH_TXEN
R12	P2.0	ETH_MDIO
R13	P2.2	ETH_RXD0
R14	P2.3	ETH_RXD1
R15	P2.4	ETH_RXER
R16	P2.7	ETH_MDC
R17	P2.8	ETH_TXD0
R18	P2.9	ETH_TXD1
R19	R3.1	BUTTON1
R20	R3.2	BUTTON2
R21	P15.8	ETH_CLK
R22	P15.9	ETH_CRS
R24	P14.0/ADC0	Potentiometer

## 2.4 Arduino Compatible Connector

The mapping of GPIOs and XMC™ pin functions to Arduino compatible functions can be found in Figure 9. The Arduino compatible connector supports

- SPI interface (SPI\_XXX)
- I2C interface (I2C\_XXX)
- UART interface (UART\_XXX)
- PWM signal outputs (PWM0-4)
- ADC input (ADC0-5)
- Interrupt input (INT0-1)

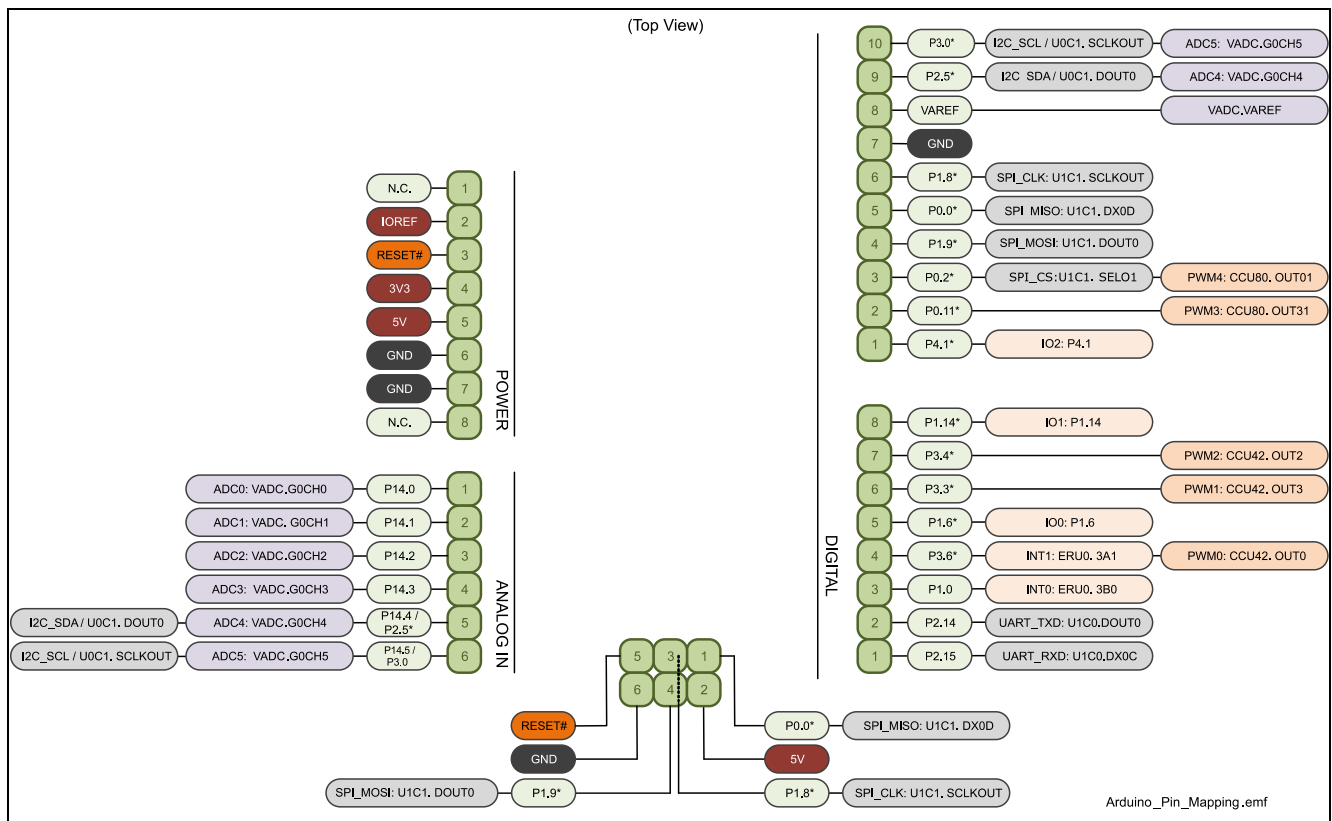

Figure 9 Mapping of Arduino Functions to XMC Pin Functions

The XMC4400 Platform2Go 5V features bi-directional voltage level shifter and therefore supports 5 V Arduino shields. Jumper JP300 (IOREF) determines whether the Arduino shield is driven with 5 V or 3.3 V.

Analog input signals ADC0-5 are limited to 3.3 V input voltage. Primarily ADC0 to ADC3 should be used as analog input, because there is no additional circuit connected to these pins, whereas ADC4 and ADC5 have additional circuitry and require an input signal with lower input impedance. ADC0 is also connected to the Potentiometer for a variable value of the analog input (optional see Table 5).

**Note:** Parallel operation of I2C and ADC4 / ADC5 is not possible, because they share the same Arduino pins.

## 2.5 User Push Buttons and User LEDs

The XMC4400 Platform2Go Series-V1.1 provides two user push buttons, two LEDs and one potentiometer. The port pins used can be found in Table 4 and Table 5.

**Table 4 XMC4400 Pin Mapping for User LEDs**

LED	XMC Pin	Resistor
LED1	P0.6	R112 (680 Ohm)
LED2	P0.7	R113 (680 Ohm)

**Table 5 XMC4400 Pin Mapping for User Push Buttons and Potentiometer**

Button	XMC Pin	Resistor
BUTTON1*	P3.1	R19
BUTTON2*	P3.2	R20
Potentiometer*	P14.0	R24

\*Note: Each push Buttons, the potentiometer and the LEDs can be disabled by removing their resistor.

Also see Table 3.

Debugging and UART-to-USB Communication

The XMC4400 Platform2Go Series-V1.1 supports debugging via 2 different channels:

- On-board debug probe
- 10-pin Cortex™ Debug Connector (not assembled)

## 2.6 On-board Debug Probe

The on-board debug probe supports Serial Wire Debug (SWD) and UART communication. Both require the installation of Segger's J-Link Driver which is part of the DAVE™ installation. DAVE™ is a highly efficient development platform for the XMC microcontroller families to simplify and shorten SW development. It can be downloaded at [www.infineon.com/dave](http://www.infineon.com/dave). The latest Segger J-Link Driver can be downloaded at <http://www.segger.com/jlink-software.html>. Table 6 shows the pin assignment of the XMC4400 used for debugging and UART communication.

## 2.7 UART Communication for XMC4200

To enable\* the optional UART communication between the XMC4400 and the XMC4200 Debugger, R1 and R2 have to be assembled with 0 Ohm, 0805 resistor.

**Table 6 XMC4400 Pins Mapping for Debugging and UART-Communication**

Pin Function	Input/Output	XMC Pin
Data pin for Debugging via SWD	I/O	TMS
Clock pin for Debugging via SWD	O	TCK
Transmit pin for UART communication (PC_RX)	O	XMC4200 Debugger P1.15 (TDX_U1C0.DOUT0)
Receive pin for UART communication (PC_TX)	I	XMC4200 Debugger P0.5 (RDX_U1C0.DX0B)
Optional* Transmit pin for UART(UART_RX)	O	XMC4400 P2.15(RXD_U1C0.DX0C)
Optional* Receive pin for UART(UART_TX)	I	XMC4400 P2.14(TXD_U1C0.DOUT0)



## 2.8 Cortex™ Debug Connector (10-pin)

The 10-pin Cortex™ Debug Connector supports Serial Wire Debug (SWD) and Serial Wire Viewer (SWV). The pin assignment of the Cortex™ Debug Connector is shown in Table 7.

**Table 7 Pin Assignment of the Cortex™ Debug Connector (X102)**

Pin No.	Signal Name	Description
1	VCC	+3.3 V
2	TMS	Serial Wire Data I/O
3	GND	Ground
4	TCK	Serial Wire Clock
5	GND	Ground
6	SWV	Serial Wire Viewer (Trace Data Out)
7	NC	Not connected
8	NC	Not connected
9	GND_Detect	Ground detect
10	RESET	Rest (active low)

## 2.9 Reset

The reset pin (PORST#) of the XMC4400 is a bi-directional pin in open drain mode. An internal pull-up resistor keeps the PORST# pin high during normal operation. A low level at this pin will force a hardware reset. In case of a MCU internal reset the PORST# pin will drive a low signal.

A reset signal can be issued by

- the on-board Reset Button (“RESET”)
- the on-board debug probe (IC101.47)
- the external debugger connected to the 10-pin Cortex™ Debug probe connector (X102)
- the Arduino Power Header (X302.3, “RESET#”)
- the pin header X1 (X1.2, “RESET#”)

An XMC™ internal circuit always ensures a save Power-on-Reset. XMC™ does not require any additional external components to generate a reset signal during power-up.

## 2.10 CAN Transceiver

The XMC4400 Platform2Go provides a CAN interface via the X3 connector. Infineon’s high speed CAN transceiver IFX1051LE for industrial application supports 3.3V I/O logic and is suitable for 12V and 24V bus systems with an excellent EMC performance. The CAN bus (signals CANH, CANL) is not terminated by a 120Ohm and needs to be terminated externally. To use the CAN pins otherwise see also Table 3.

**Table 8 CAN Signals and XMC4400 Pin Mapping**

Signal Name	Pin No. at Pin Header X1	XMC Pin, XMC Function	Pin No. at Pinheader X3
CANH	-	-	X3.1
CANL	-	-	X3.2
CAN_TX	X1.19	P1.12, CAN_TX	-
CAN_RX	X1.20	P1.13, CAN_RX	-

## 2.11 Serial Flash Memory

The XMC4400 Platform2Go provides a 32 Mbit serial flash memory from Microchip Technology (type: SST26VF032BT-104I/SM) interfaced to XMC4400 through a SPI interface. The SPI interface can be configured as single, dual or quad SPI. To use the Serial Flash Memory pins otherwise see also Table 3.

**Table 9 XMC4400 Pins Mapping for Serial Flash Memory**

<b>XMC Pin</b>	<b>Function in qSPI Mode, XMC Function</b>	<b>Function in SPI Mode, XMC Function</b>
P0.8	Clock, U0C0.SCLKOUT	Clock, U0C0.SCLKOUT
P1.11	Chip Select, U0C0.SELO0	Chip Select, U0C0.SELO0
P1.5	Data Line 0 I/O, U0C0.DOUT0	Master Out Slave In (MOSI, MTSR), U0C0.DOUT0
P1.4	Data Line 1, U0C0.DOUT1	Master In Slave Out (MISO, MRST), U0C0.DOUT1
P1.3	Data Line 2, U0C0.DOUT2	HOLD (low active)
P1.2	Data Line 3, U0C0.DOUT3	Write Protection (low active)

## 2.12 Ethernet

The XMC4400 Platform2Go provides an Ethernet Phy and RJ45 plug.

**Table 10 XMC4400 Pins used for Ethernet**

<b>XMC Pin</b>	<b>Ethernet Function</b>	<b>XMC Function</b>
P15.9	Carrier Sense / Receive Data Valid	ETH0.CRS_DVC
P15.8	Clock Input	ETH0.CLK_RMII
P5.1	Interrupt ( <b>disabled*</b> by default; Enabled via solder resistor <b>R401</b> )	GPIO P5.1
P2.10	LED	GPIO P2.10
P2.9	Transmit Data Line 1	ETH0.TXD1
P2.8	Transmit Data Line 0	ETH0.TXD0
P2.7	Management Data Clock	ETH0.MDC
P2.4	Receive Error	ETH0.RXERA
P2.3	Receive Data Line 1	ETH0.RXD1A
P2.2	Receive Data Line 0	ETH0.RXD0A
P2.0	Management Data In/Out	ETH0.MDO/MDIB
P0.4	Transmit Enable	ETH0.TX_EN

**\*Note:** Interrupt can be enabled by soldering R401 with 0805 resistor.

### 2.13 Boot Option

During power-on-reset the XMC4400 latches the signal level at the pins TMS and TCK. Based on the logic levels latched at these pins after reset the XMC4400 starts booting in different modes. TMS and TCK pins are used for debugging and by default program execution is always starting from on-chip flash (normal mode).

The XMC4400 Platform2Go Series-V1.1 does not support the selection of the boot options by switches directly. In case of no external debug probe is used the boot mode can be influenced by applying 1 kOhm pull-up- or pull-down resistors to TMS and TCK pins. These pins are available at the 10-pin debug connector X102.

**Table 11 Boot Mode Selection with external Pull Resistors**

Logic Level at TMS during Reset	Logic Level at TCK during Reset	Boot Mode
High	Low	Normal Mode (boot from on-chip flash) (DEFAULT)
Low	Low	ASC BSL Mode (boot from UART)
High	High	BMI Customized Boot Mode
Low	High	CAN BSL Mode (boot from CAN)

## 3 Production Data

This chapter covers schematics, board dimensions, component placement and the list of material.

### 3.1 Schematics

In the following figures shows the schematics of the XMC4400 Platform2Go Series-V1.1 in.

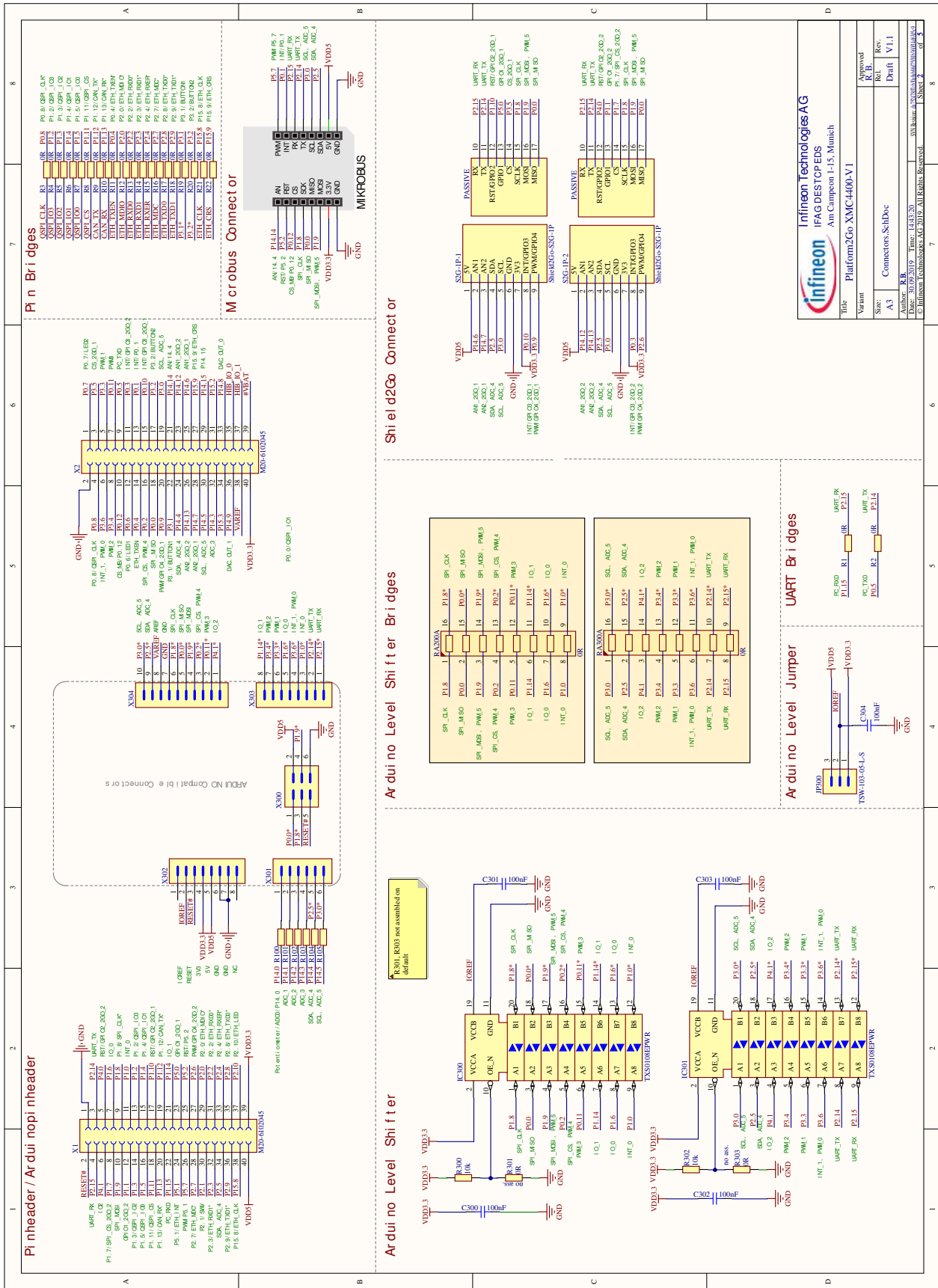

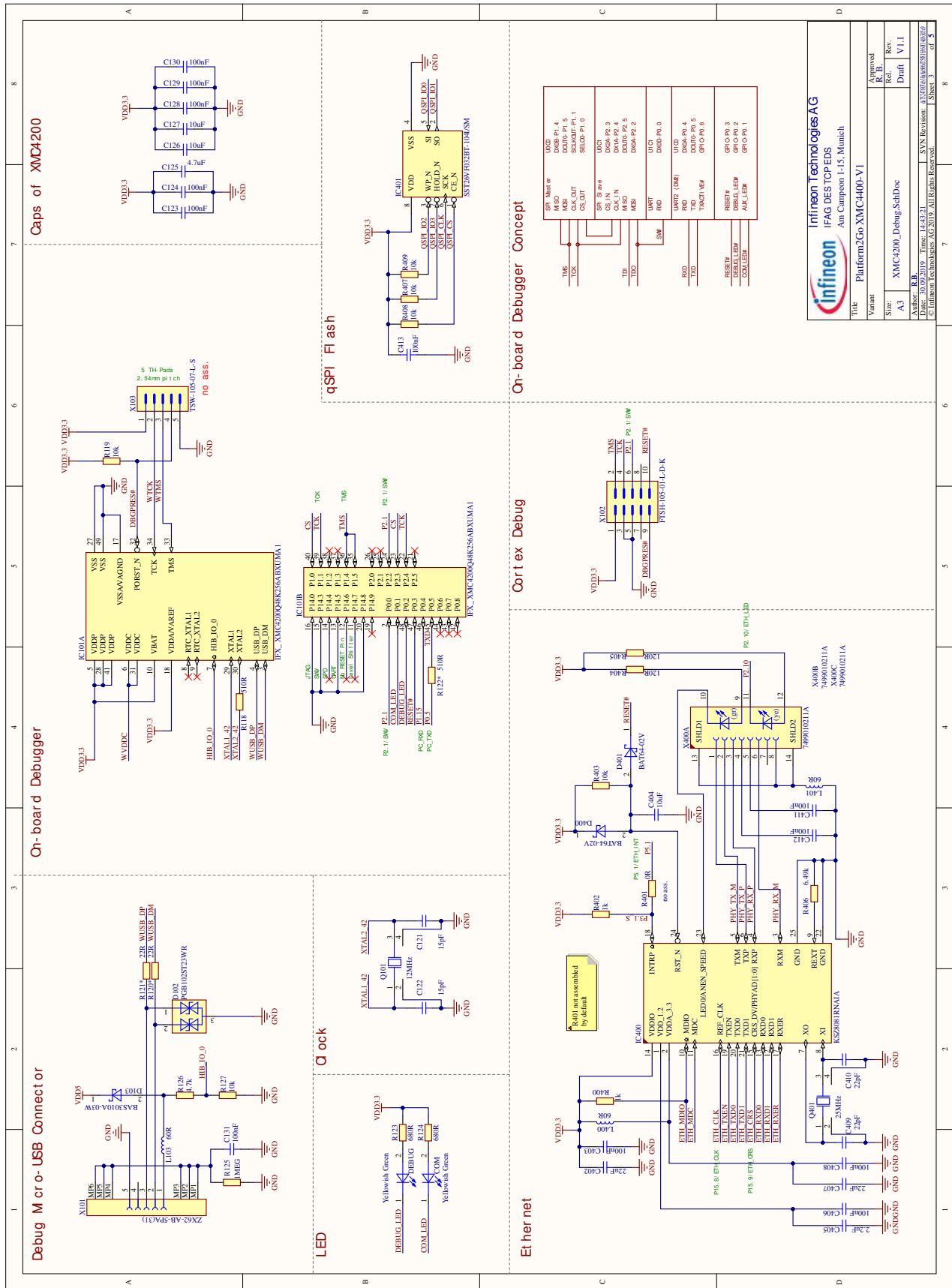

Figure 11 MXC\_4400\_Debug Schematic: OBD Probe, Ethernet, Quad-SPI Memory

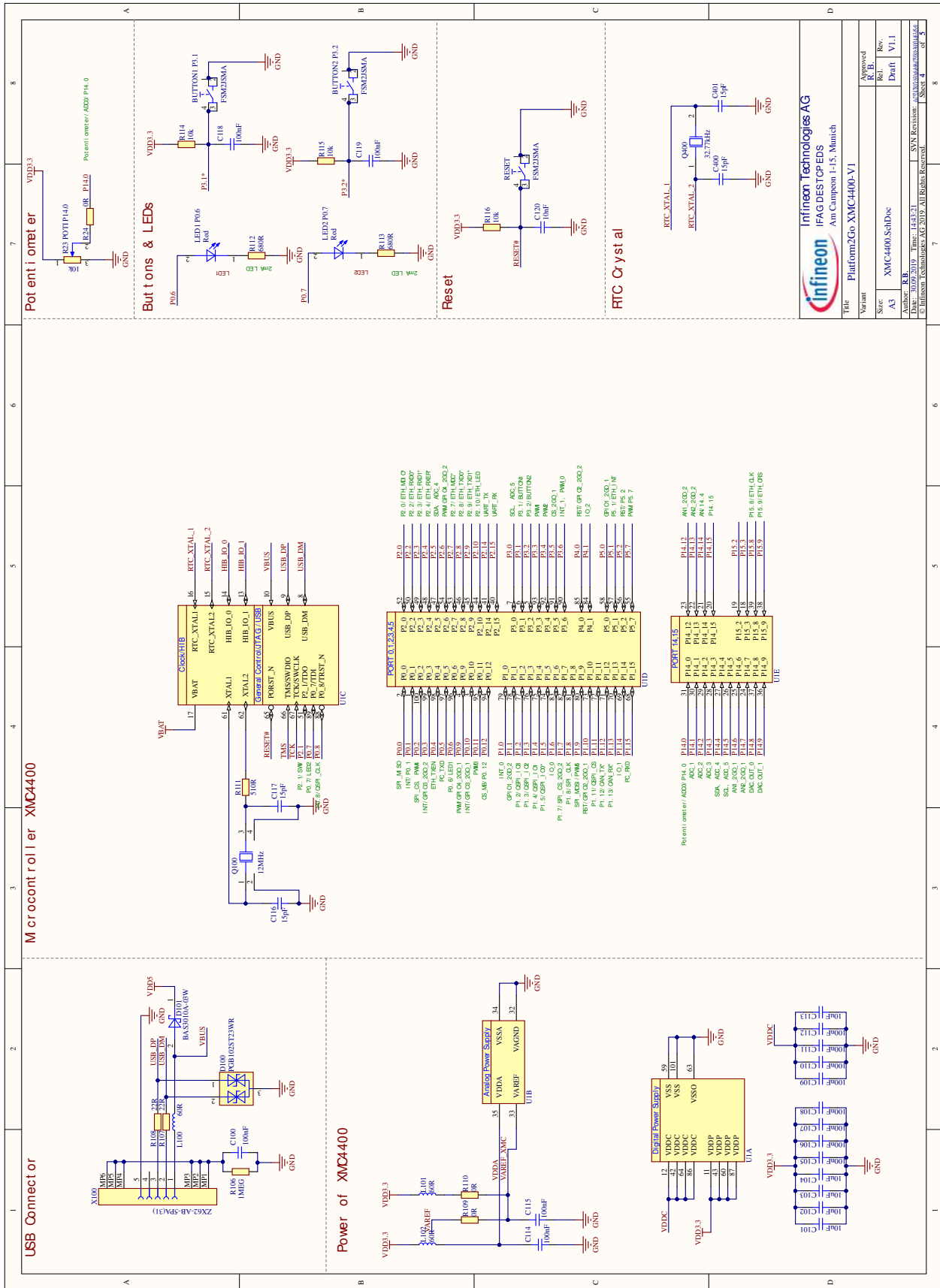
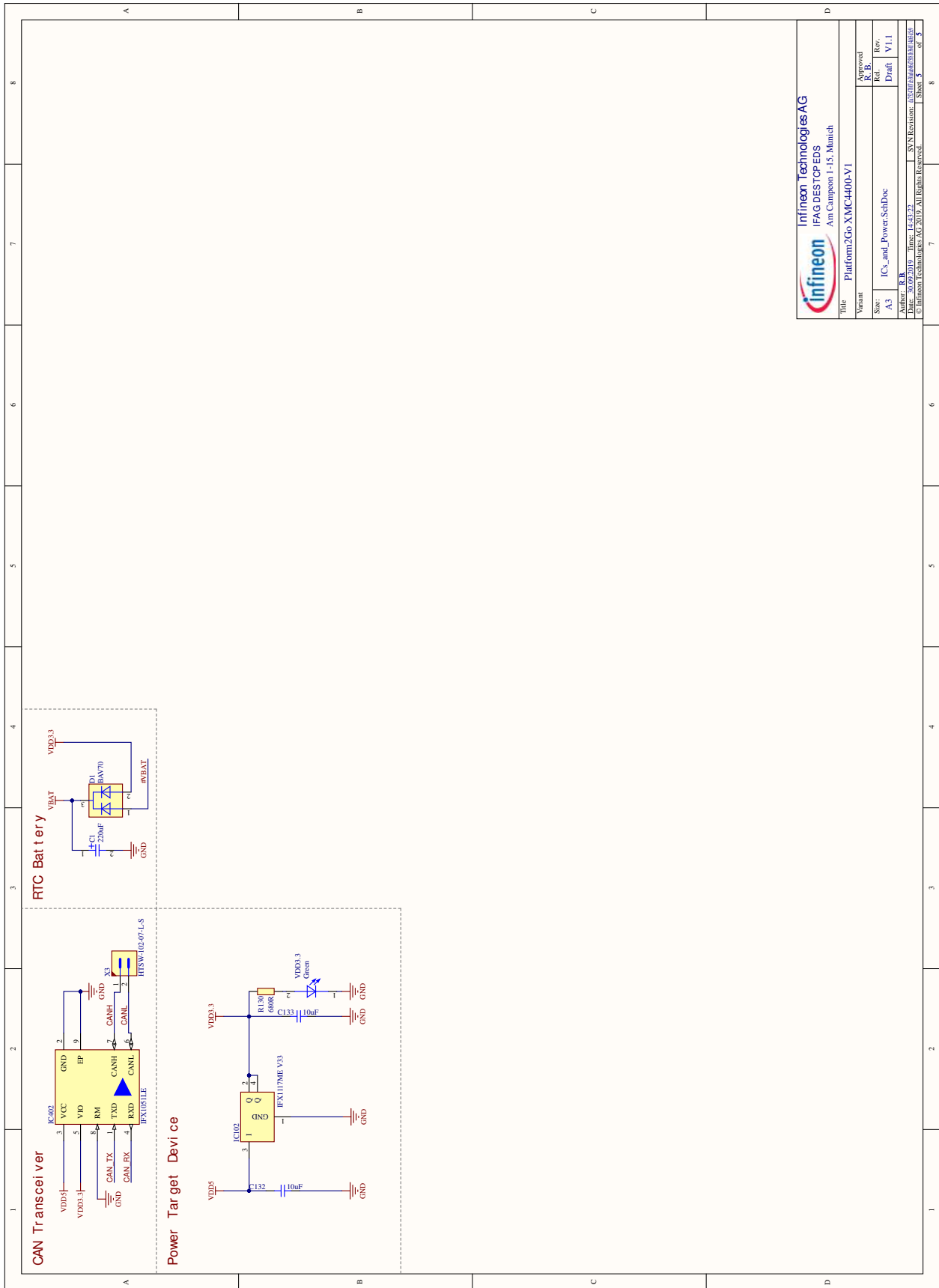

Figure 12 XMC4400 Schematic: USB connector, Microcontroller pins and power, Potentiometer Buttons and LEDs



		<b>Infineon Technologies AG</b> IFAG DEST CPEDS Am Coulson 1-15, Munich	
Title	Platform2Go XMC4400-V1	Approved R.B.	
Variant		Rel.	
Size	IC_and_PowerSchDoc	Draft	V.1.1
Author	R.B.		
Created	2019-08-30 13:55		
File Path	Infineon Technologies AG 2019 All Rights Reserved		
		Sheet 5	of 5

Figure 13 ICs and Power Schematic: Can Transceiver, RTC Battery, Power

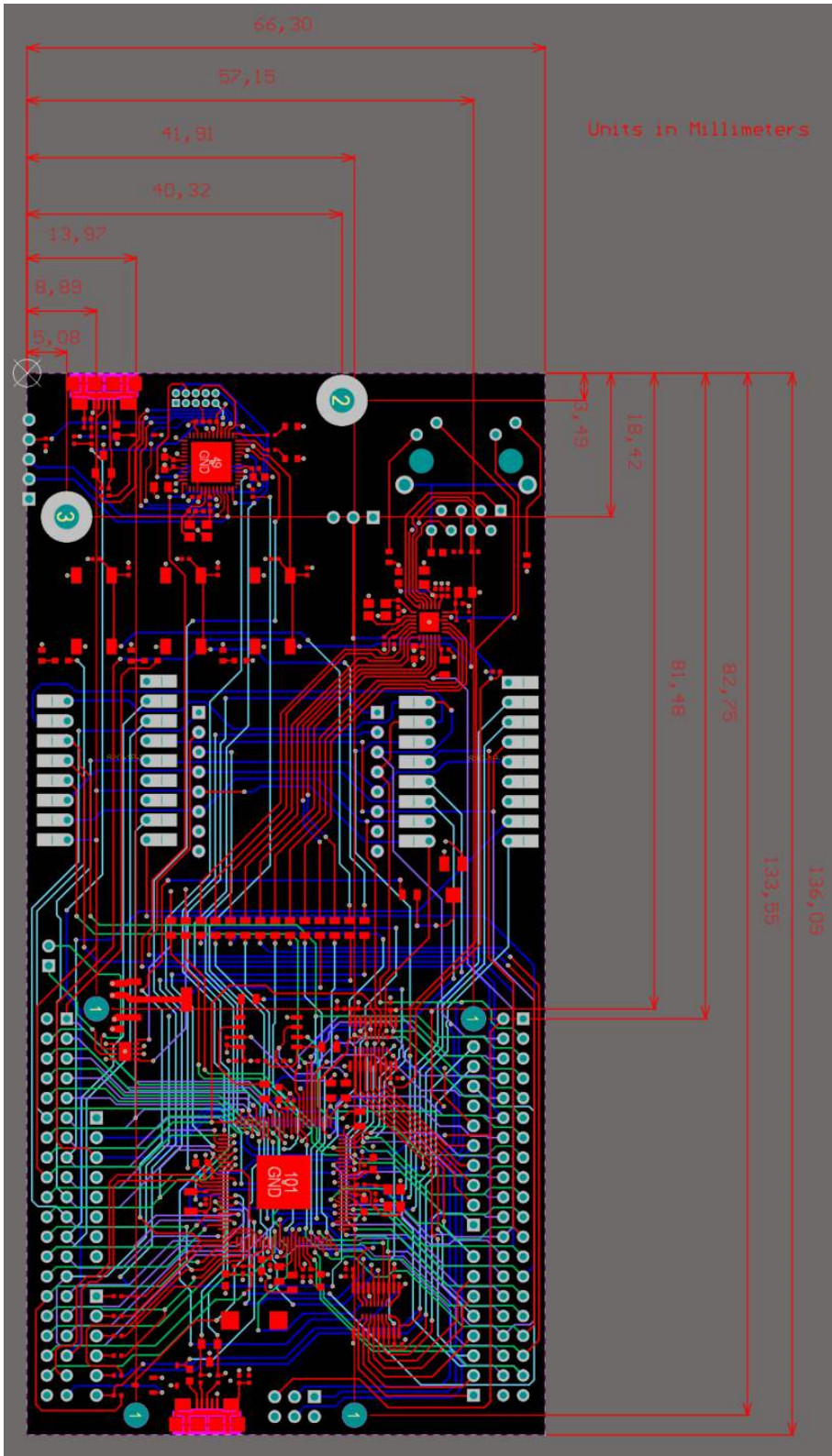

Figure 14 Geometry



### 3.2 List of Material

The list of material is valid for the Platform2Go XMC4400 Lite/3.3V/5V.

**Table 12 List of Material**

Description	Designator	PackageReference	Value	Quantity	Not fitted in*
Micro Miniature Pushbutton Switch	BUTTON1 P3.1, BUTTON2 P3.2, RESET		FSM2JSMA	3	
Solid Tantalum Surface Mount Chip Capacitor	C1	7451 / 2920	220uF	1	
Surface Mount Multilayer Ceramic Chip Capacitor	C100, C109, C110, C111, C112, C114, C115, C118, C119	0402 / 1005	100nF	9	
Surface Mount Multilayer Ceramic Chip Capacitor	C300, C301, C302, C303	0402 / 1005	100nF	4	A,C
Surface Mount Multilayer Ceramic Chip Capacitor	C304	0402 / 1005	100nF	1	
Chip Monolithic Ceramic Capacitor	C101, C102, C103, C104, C126	0603 / 1608	10uF	5	
Multilayer Ceramic Chip Capacitor	C105, C106, C107, C108	0402 / 1005	100nF	4	
Chip Multilayer Ceramic Capacitor	C113, C127, C132, C133	0603 / 1608	10uF	4	
Chip Monolithic Ceramic Capacitor	C116, C117	0402 / 1005	15pF	2	
Chip Monolithic Ceramic Capacitor	C120	0402 / 1005	10nF	1	
Chip Monolithic Ceramic Capacitor	C121, C122	0402 / 1005	15pF	2	
Chip Monolithic Ceramic Capacitor	C123, C124, C128, C129, C130, C131	0402 / 1005	100nF	6	
Chip Monolithic Ceramic Capacitor	C125	0805 / 2012	4.7uF	1	
Chip Monolithic Ceramic Capacitor	C400, C401	0402 / 1005	15pF	2	C,D
Chip Monolithic Ceramic Capacitor	C402	0603 / 1608	22uF	1	C,D

Chip Monolithic Ceramic Capacitor	C403, C406, C408, C411, C412, C413	0402 / 1005	100nF	6	C,D
Multilayer Ceramic Capacitor (High dielectric type)	C404	0805 / 2012	10uF	1	C,D
Chip Monolithic Ceramic Capacitor	C405	0402 / 1005	2.2uF	1	C,D
Multilayer Ceramic Chip Capacitor	C407	0805 / 2012	22uF	1	C,D
Chip Monolithic Ceramic Capacitor	C409, C410	0402 / 1005	22pF	2	C,D
PICOLED, Yellowish Green	COM, DEBUG		LED-SMD-SMLP13BC8T	2	
Overvoltage Diode	D1	SOT23	BAV70	1	
TVS Diode, Bi-directional Low Capacitance	D100, D102		PGB102ST23WR	2	
Medium Power AF Schottky Diode	D101, D103		BAS3010A-03W	2	
Silicon Schottky Diode	D400, D401		BAT64-02V	2	C,D
Performance of the ARM Cortex-M4 Core with Powerful On-Chip Peripheral Subsystems, Temp Range(-40Å°C to 125Å°C)	IC101		IFX_XMC4200Q48K256ABXUMA1	1	
Voltage Regulator, 3.3 V Output	IC102		IFX1117ME V33	1	
8-Bit Bidirectional Voltage-Level Translator for Open-Drain and Push-Pull Applications	IC300, IC301		TXS0108EPWR	2	A,C
10Base-T/100Base-TX PHY with RMII with 25MHz crystal/clock input and 50MHz RMII REF_CLK output, Industrial Temperature	IC400		KSZ8081RNAIA	1	C,D
Serial NOR Flash Memory, 32Mb, 2.7-3.6V, Multiple I/O, 108MHZ Speed	IC401		SST26VF032BT-104I/SM	1	C,D
Industrial High Speed CAN-FD Transceiver	IC402		IFX1051LE	1	C,D
Through hole .025" SQ Post Header, 2.54mm pitch, 3 pins, vertical, Single Row	JP300		TSW-103-05-L-S	1	C,D

**Production Data**

For Power Lines; For General	L100, L101, L102, L103	0603 / 1608	60R	4	
For Power Lines; For General	L400, L401	0603 / 1608	60R	2	C,D
	LED1 P0.6, LED2 P0.7		Red	2	
mikroBUS Host Socket	MIKROBUS			2	
9 Pin of the Socket	Headers		'S2G-1P, S2G-1P-2	2	
8 Pin of the Socket	Headers		'S2G-1P, S2G-1P-3	2	
SMD Crystal Unit for Automotive Application, 12.000MHz	Q100, Q101		12MHz	2	
SMD, 32.768kHz $\pm$ 20PPM, 12.5pF Crystal Unit	Q400		32.77kHz	1	C,D
SMD Crystal Unit for Automotive Application, 25.000MHz	Q401		25MHz	1	C,D
Standard Thick Film Chip Resistor, 0R/50V	R1, R2, R401	0805 / 2012	0R	3	N
General Purpose Chip Resistor	R3 - R22, R24	0805 / 2012	0R	20	
Standard Thick Film Chip Resistor	R100, R101, R102, R103, R104, R105	0402 / 1005	100R	6	
Standard Thick Film Chip Resistor	R106, R125	0402 / 1005	1MEG	2	
Standard Thick Film Chip Resistor	R107, R108, R120*, R121*	0402 / 1005	22R	4	
Standard Thick Film Chip Resistor, 0R/50V	R110	0402 / 1005	0R	1	
Standard Thick Film Chip Resistor, 0R/50V	R109, R301, R303	0402 / 1005	0R	4	N
Surface Mount Single Turn Trimmer, Model 23A - J Hook	R23 POT1 P14, 15		10k	1	
Standard Thick Film Chip Resistor	R111, R118, R122*	0402 / 1005	510R	3	
Standard Thick Film Chip Resistor	R112, R113, R130	0603 / 1608	680R	3	
Standard Thick Film Chip Resistor	R114, R115, R116, R119, R127	0402 / 1005	10k	5	
Standard Thick Film Chip Resistor	R403, R407, R408, R409	0402 / 1005	10k	4	C,D

**Production Data**

Standard Thick Film Chip Resistor	R300, R302	0402 / 1005	10k	2	A,C
Automotive Grade Thick Film Chip Resistor	R123, R124	0603 / 1608	680R	2	
Standard Thick Film Chip Resistor	R126	0402 / 1005	4.7k	1	
Standard Thick Film Chip Resistor	R400, R402	0402 / 1005	1k	2	C,D
Standard Thick Film Chip Resistor	R404, R405	0603 / 1608	120R	2	C,D
Standard Thick Film Chip Resistor	R406	0402 / 1005	6.49k	1	C,D
Chip Resistor Array, Temp Range (-55 to 125°C)	RA200, RA300		0R	2	B,D
XMC4000 Family Microcontroller for Industrial Applications, ARM® Cortex®-M4, 32-bit processor core, Flash 512 Kbytes, SRAM 80 Kbytes (Temperature Range -40°C to 125°C)	U1		IFX_XMC4400-F100	1	
Surface Mount LED, Green, 570nm	VDD3.3		Green	1	
2.54mm PC/104 Connector, Stackthrough	X1, X2		M20-6102045	2	N
Micro-USB 2.0 Standard, Type AB, Bottom Mount, Shell SMT	X100, X101		ZX62-AB-5PA(31)	2	
THT Micro Header, 1.27mm pitch, 10 pin, vertical, double row, keying shroud, DAP	X102		FTSH-105-01-L-D-K	1	N
Through hole .025" SQ Post Header, 2.54mm pitch, 5 pin, vertical, single row	X103		TSW-105-07-L-S	1	N
Through hole .025" SQ Post Header, 2.54mm pitch, 2 pin, vertical, double row	X3		HTSW-102-07-L-S	1	
Through hole .025" SQ Post Header, 2.54mm pitch, 6 pin, vertical, double row	X300		Header 3X2A	1	
Through hole .025" SQ Post Header, 2.54mm pitch, 6 pin, vertical, single row	X301		TSW-106-07-L-S	1	

Production Data

Through hole .025" SQ Post Header, 2.54mm pitch, 8 pin, vertical, single row	X302		TSW-108-23-F-S	1	
Through hole .025" SQ Post Header, 2.54mm pitch, 8 pin, vertical, single row	X303		TSW-108-07-L-S	1	
Through hole .025" SQ Post Header, 2.54mm pitch, 10 pin, vertical, single row	X304		TSW-110-07-L-S	1	
RJ45 Connector with Integrated Transformer, 8 positions, 8 contacts, 2 LEDs (green, yellow), Shielded	X400		7499010211A	1	C,D

\*Agenda:

- A: XMC4400 Platform2Go for 3.3V Shields
- B: XMC4400 Platform2Go for 5V Shields
- C: XMC4400 Platform2Go Lite for 3.3V Shields
- D: XMC4400 Platform2Go Lite for 5V Shields
- N: Not assembled in all Versions

[www.infineon.com](http://www.infineon.com)

Published by Infineon Technologies AG