

GENERAL DESCRIPTION

The SP6669 is a synchronous current mode PWM step down (buck) converter capable of delivering up to 800mA of current. It features a pulse skip mode (PSM) for light load efficiency and a LDO mode for 100% duty cycle.

With a 2.5V to 6.0V input voltage range and a 1.5MHz switching frequency, the SP6669 allows the use of small surface mount inductors and capacitors ideal for battery powered portable applications. The internal synchronous switch increases efficiency and eliminates the need for an external Schottky diode. Low output voltages are easily supported with the 0.6V feedback reference voltage.

Built-in over temperature and output over voltage lock-out protections insure safe operations under abnormal operating conditions.

The SP6669 is offered in a RoHS compliant, "green"/halogen free 5-pin SOT23 package.

APPLICATIONS

- **Portable Equipment**
- **Battery Operated Equipment**
- **Audio-Video Equipment**
- **Networking & Telecom Equipment**

FEATURES

- **Guaranteed 800mA Output Current**
 - Input Voltage: 2.5V to 6.0V
- **1.5MHz PWM Current Mode Control**
 - 100% Duty Cycle LDO Mode Operations
 - Achieves 97% Efficiency
- **0.6V 2% Accurate Reference**
- **Excellent Line/Load Transient Response**
- **18µA Quiescent Current**
- **Over Temperature Protection**
- **RoHS Compliant "Green"/Halogen Free 5-Pin SOT23 Package**

TYPICAL APPLICATION DIAGRAM

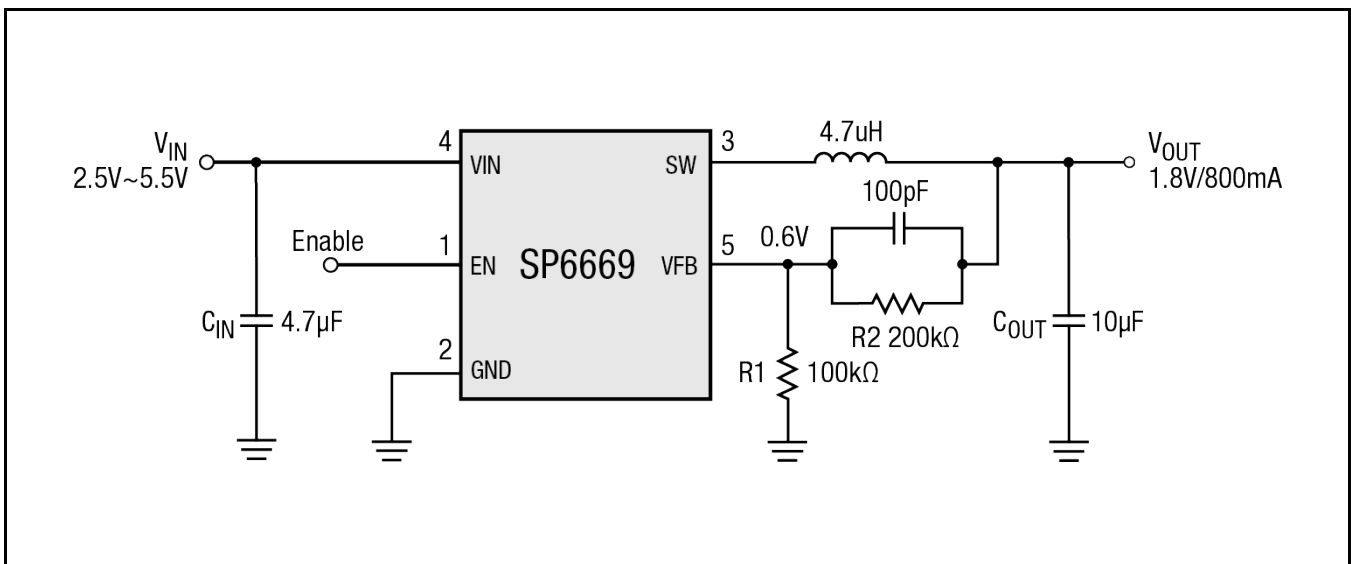

Fig. 1: SP6669 Application Diagram (Adj. version shown)

800mA 1.5MHz Synchronous Step Down Converter

ABSOLUTE MAXIMUM RATINGS

These are stress ratings only and functional operation of the device at these ratings or any other above those indicated in the operation sections of the specifications below is not implied. Exposure to absolute maximum rating conditions for extended periods of time may affect reliability.

Input Voltage V_{IN} -0.3V to 6.6V
 Enable V_{FB} Voltage..... -0.3V to V_{IN}
 SW Voltage..... -0.3V to ($V_{IN}+0.3V$)
 Peak Switch Sink/Source Current 1.3A
 Junction Temperature 150°C
 Storage Temperature..... -65°C to 150°C
 Lead Temperature (Soldering, 10 sec) 260°C
 ESD Rating (HBM - Human Body Model) 2kV
 ESD Rating (CDM - Charged Device Model).....500V

OPERATING RATINGS

Input Voltage Range V_{IN}2.5V to 6.0V
 Operating Temperature Range..... -40°C to 85°C
 Operating Junction Temperature¹125°C
 Thermal Resistance θ_{JA} 134.5°C/W
 Thermal Resistance θ_{JC} 81°C/W

Note 1: T_J is a function of the ambient temperature T_A and power dissipation P_D ($T_J = T_A + P_D \times \theta_{JA}$).

ELECTRICAL SPECIFICATIONS

Specifications with standard type are for an Operating Junction Temperature of $T_J = 25^\circ\text{C}$ only; limits applying over the full Operating Junction Temperature range are denoted by a "•". Minimum and Maximum limits are guaranteed through test, design, or statistical correlation. Typical values represent the most likely parametric norm at $T_A = 25^\circ\text{C}$, and are provided for reference purposes only. Unless otherwise indicated, $V_{IN} = 3.6V$.

Parameter	Min.	Typ.	Max.	Units	Conditions
Feedback Current I_{VFB}			±30	nA	
Regulated Feedback Voltage V_{FB}	0.588	0.600	0.612	V	•
Reference Voltage Line Regulation ΔV_{FB}			0.4	%/V	• $V_{IN}=2.5V$ to 5.5V
Output Over-Voltage Lockout ΔV_{OVL}	20	50	80	mV	$\Delta V_{OVL} = V_{OVL} - V_{FB}$ (Adj.)
Output Voltage Line Regulation ΔV_{OUT}			0.6	%/V	• $V_{IN}=2.5V$ to 5.5V
Peak Inductor Current I_{PK}	1.2	2.3		A	$V_{IN}=3V$, $V_{FB}=0.5V$
Output Voltage Load Regulation $V_{LOADREG}$		0.5		%	
Quiescent Current ¹ I_Q		18		µA	$V_{FB}=0.65V$
Shutdown Current $I_{SHUTDOWN}$		0.1	1	µA	$V_{EN}=0V$, $V_{IN}=4.2V$
Oscillator Frequency f_{OSC}	1.2	1.5	1.8	MHz	• $V_{FB}=0.6V$
		750		kHz	• $V_{FB}=0V$ or $V_{OUT}=0V$
RDS(ON) of PMOS R_{PFET}		0.24		Ω	$I_{SW}=100mA$
RDS(ON) of NMOS R_{NFET}		0.24		Ω	$I_{SW}=100mA$
SW Leakage I_{LSW}			±1	µA	$V_{EN}=0V$, $V_{SW}=0V$ or 5V, $V_{IN}=5V$
Enable Threshold V_{EN}			1.2	V	•
Shutdown Threshold V_{EN}	0.4			V	•
EN Leakage Current I_{EN}			±1	µA	•

Note 1: The dynamic quiescent current is higher due to the gate charge being delivered at the switching frequency.

BLOCK DIAGRAM

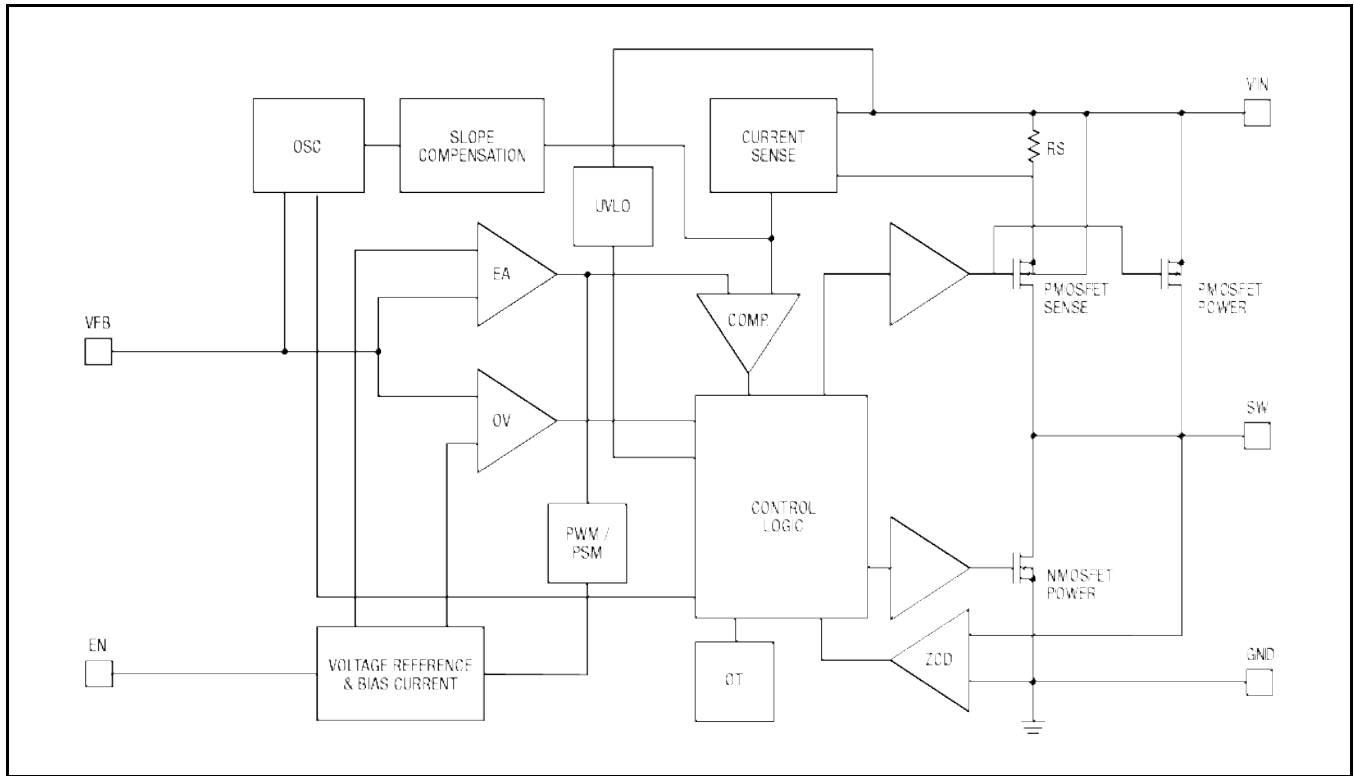

Fig. 2: SP6669 Block Diagram

PIN ASSIGNMENT

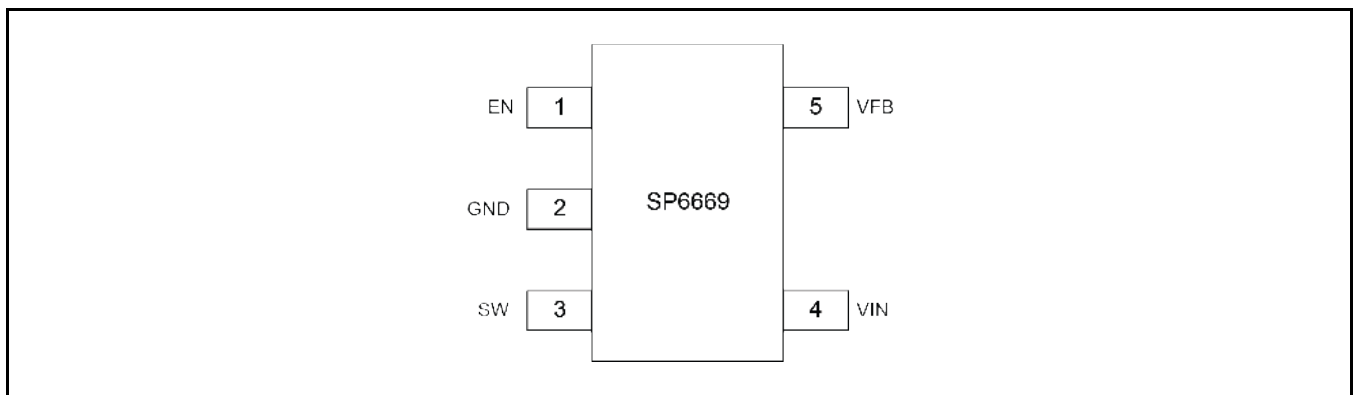

Fig. 3: SP6669 Pin Assignment

PIN DESCRIPTION

Name	Pin Number	Description
EN	1	Enable Pin. Do not leave the pin floating. $V_{EN} < 0.4V$: Shutdown mode $V_{EN} > 1.2V$: Device enabled
GND	2	Ground Signal
SW	3	Switching Node
VIN	4	Power Supply Pin. Must be decoupled to ground with a 4.7 μ F or greater ceramic capacitor.
VFB	5	Feedback Input Pin. Connect VFB to the center point of the resistor divider.

ORDERING INFORMATION

Part Number	Operating Temperature Range	Package	Packing Method	Lead-free
SP6669AEK-L/TRR3	-40°C ≤ T _A ≤ +85°C	SOT23-5	Tape & Reel	Yes
SP6669EB	SP6669 Evaluation Board			

Note: for most up-to-date ordering information and additional information on environmental rating, go to www.maxlinear.com/SP6669

Note that the SP6669 series is packaged in Tape and Reel with a reverse part orientation as per the following diagram

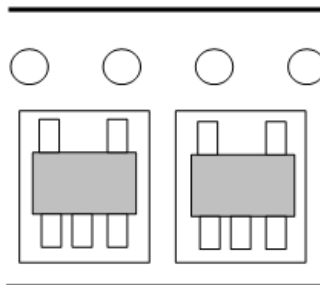

800mA 1.5MHz Synchronous Step Down Converter

TYPICAL PERFORMANCE CHARACTERISTICS

All data taken at $V_{IN} = 2.7V$ to $5.5V$, $T_J = T_A = 25^\circ C$, unless otherwise specified - Schematic and BOM from Application Information section of this datasheet.

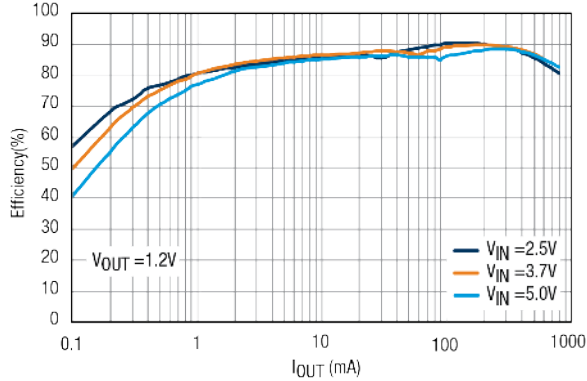

Fig. 4: Efficiency vs Output Current $V_{OUT} = 1.2V$

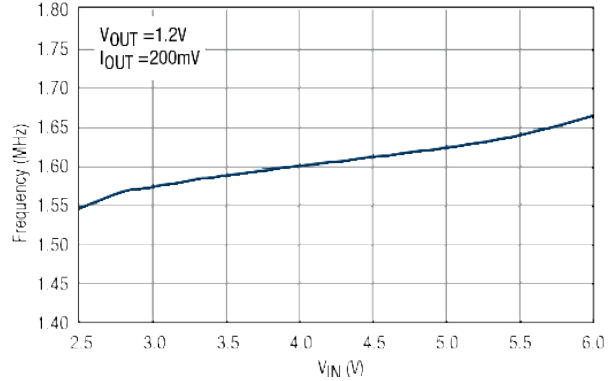

Fig. 5: Oscillator Frequency vs. Input Voltage

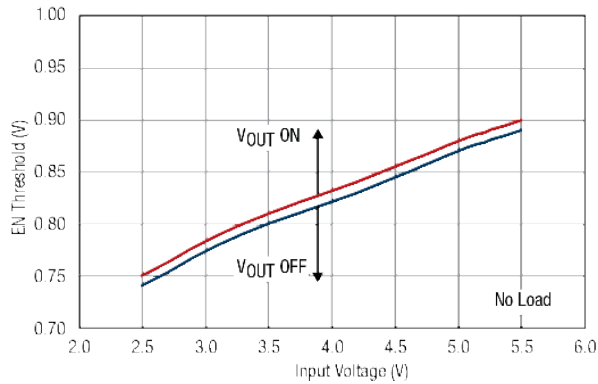

Fig. 6: EN Pin Threshold vs. Input Voltage

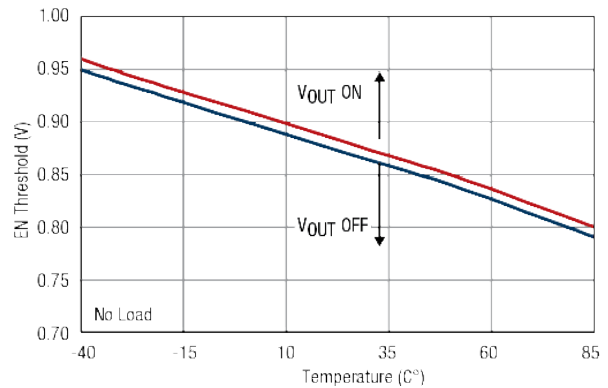

Fig. 7: EN Pin Threshold vs. Temperature

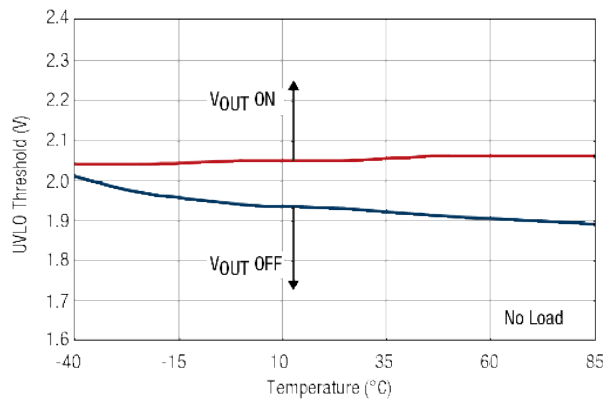

Fig. 8: UVLO Threshold vs. Temperature

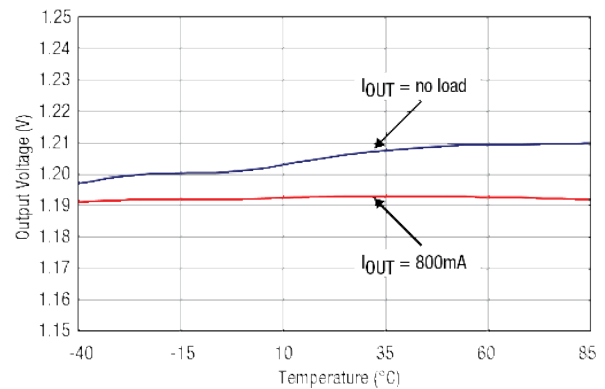

Fig. 9: Output Voltage vs Temperature

800mA 1.5MHz Synchronous Step Down Converter

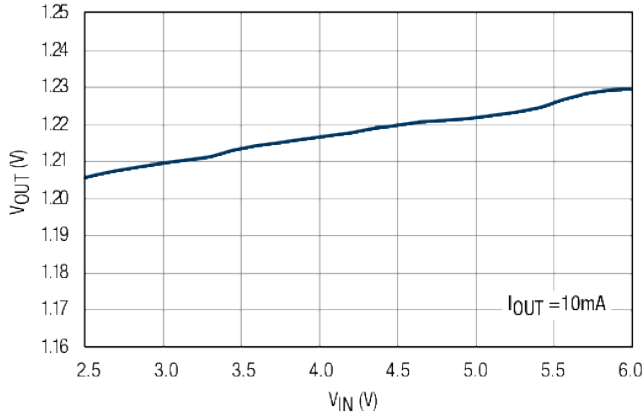

Fig. 10: Line Regulation

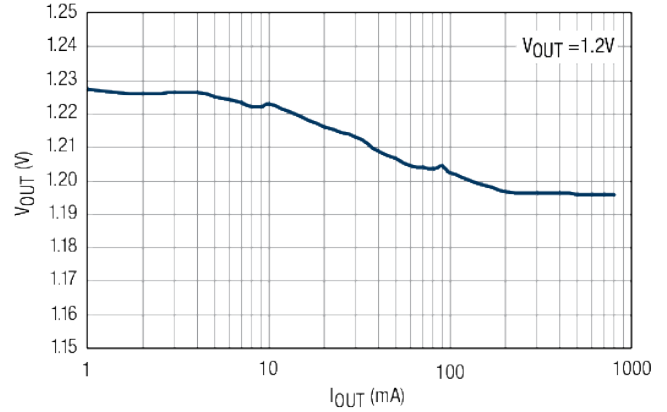

Fig. 11: Load Regulation

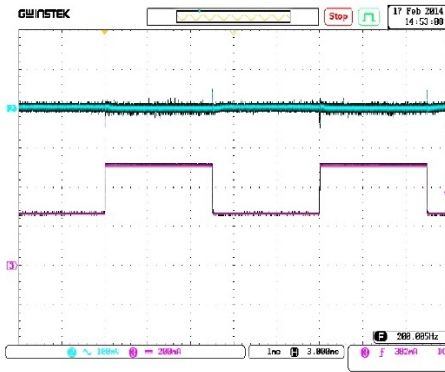

Fig. 12: Load Transient Response, Iout 250mA to 500mA, Vout = 1.2V

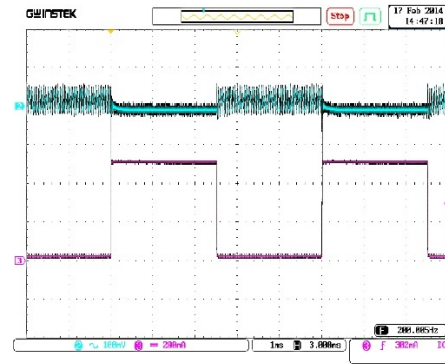

Fig. 13: Load Transient Response, Iout 10mA to 500mA, Vout = 1.2V

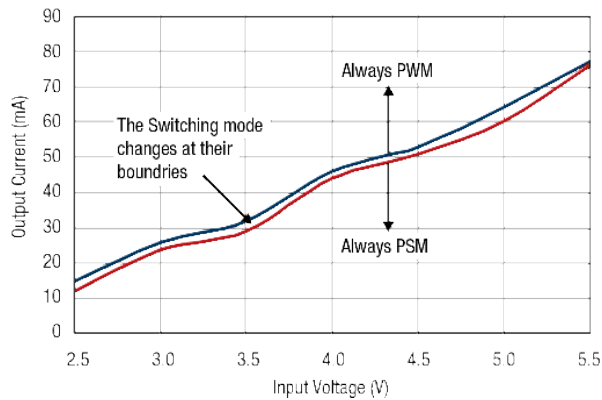

Fig. 14: PSM / PWM Boundaries

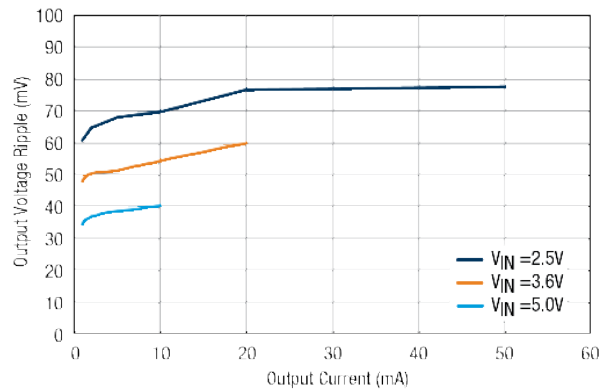

Fig. 15: Output Voltage Ripple vs Output Current

800mA 1.5MHz Synchronous Step Down Converter

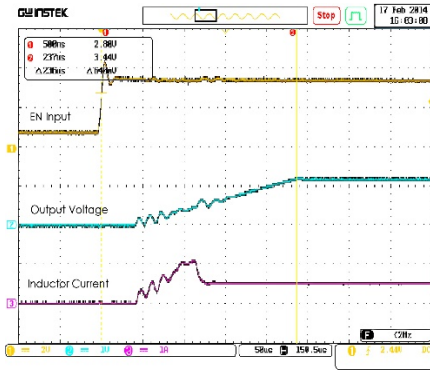

Fig. 16: Power-ON from EN Pin

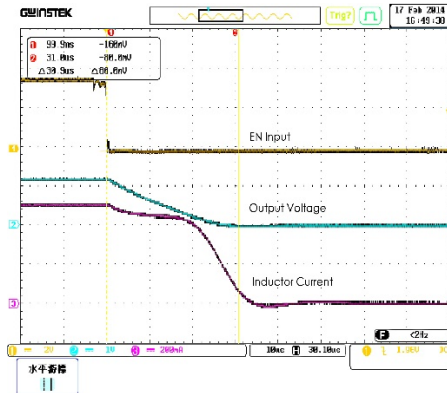

Fig. 17: Power-OFF from EN Pin

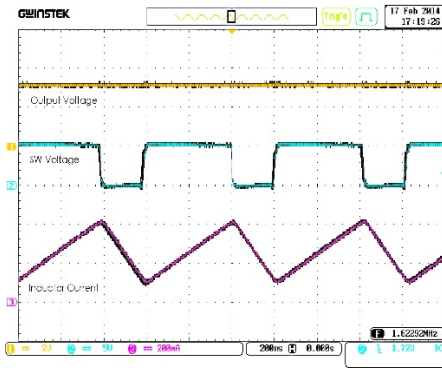

Fig. 18: PWM Operation

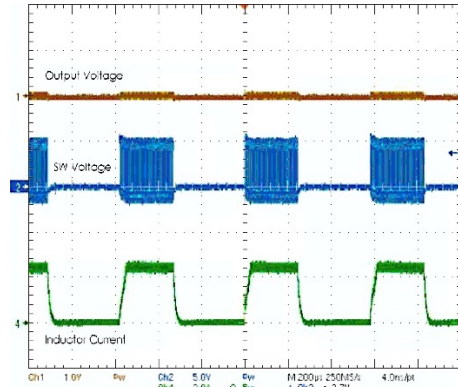

Fig. 19: Short Circuit Response

THEORY OF OPERATION

APPLICATIONS

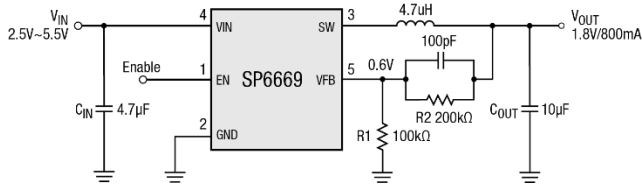

Fig. 20: Typical Application Circuit

INDUCTOR SELECTION

Inductor ripple current and core saturation are two factors considered to select the inductor value.

$$\text{Eq. 1: } \Delta I_L = \frac{1}{f \cdot L} V_{OUT} \left(1 - \frac{V_{OUT}}{V_{IN}} \right)$$

Equation 1 shows the inductor ripple current as a function of the frequency, inductance, V_{IN} and V_{OUT} . It is recommended to set the ripple current between 30% to 40% of the maximum load current. A low ESR inductor is preferred.

C_{IN} AND C_{OUT} SELECTION

A low ESR input capacitor can prevent large voltage transients at V_{IN} . The RMS current rating of the input capacitor is required to be larger than I_{RMS} calculated by:

$$\text{Eq. 2: } I_{RMS} \cong I_{OMAX} \frac{\sqrt{V_{OUT}(V_{IN} - V_{OUT})}}{V_{IN}}$$

The ESR rating of the capacitor is an important parameter to select C_{OUT} . The output ripple V_{OUT} is determined by:

$$\text{Eq. 3: } \Delta V_{OUT} \cong \Delta I_L \left(ESR + \frac{1}{8 \cdot f \cdot C_{OUT}} \right)$$

Higher values, lower cost ceramic capacitors are now available in smaller sizes. These capacitors have high ripple currents, high voltage ratings and low ESR that makes them ideal for switching regulator applications. As C_{OUT} does not affect the internal control loop

stability, its value can be optimized to balance very low output ripple and circuit size. It is recommended to use an X5R or X7R rated capacitors which have the best temperature and voltage characteristics of all the ceramics for a given value and size.

SETTING OUTPUT VOLTAGE

The output voltage is determined by:

$$\text{Eq. 4: } V_{OUT} = 0.6V \cdot \left(1 + \frac{R_2}{R_1} \right)$$

THERMAL CONSIDERATIONS

Although the SP6669 has an on board over temperature circuitry, the total power dissipation it can support is based on the package thermal capabilities. The formula to ensure safe operation is given in note 1.

PCB LAYOUT

The following PCB layout guidelines should be taken into account to ensure proper operation and performance of the SP6669:

- 1- The GND, SW and V_{IN} traces should be kept short, direct and wide.
- 2- V_{FB} pin must be connected directly to the feedback resistors. The resistor divider network must be connected in parallel to the C_{OUT} capacitor.
- 3- The input capacitor C_{IN} must be kept as close as possible to the V_{IN} pin.
- 4- The SW and VFB nodes should be kept as separate as possible to minimize possible effects from the high frequency and voltage swings of the SW node.
- 5- The ground plates of C_{IN} and C_{OUT} should be kept as close as possible.

OUTPUT VOLTAGE RIPPLE FOR V_{IN} CLOSE TO V_{OUT}

When the input voltage V_{IN} is close to the output voltage V_{OUT} , the SP6669 transitions smoothly from the switching PWM converter mode into a LDO mode. The following diagram shows the output voltage ripple versus the input voltage for a 3.3V output setting and a 200mA current load.

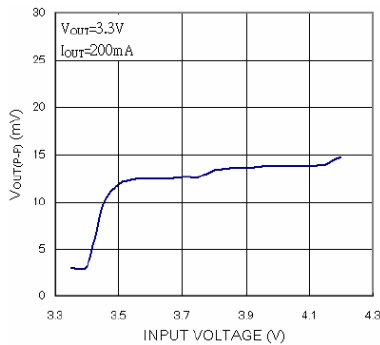

Fig. 20: V_{OUT} Ripple Voltage for V_{IN} decreasing close to V_{OUT}

DESIGN EXAMPLE

In a single Lithium-Ion battery powered application, the V_{IN} range is about 2.7V to 4.2V. The desired output voltage is 1.8V.

The inductor value needed can be calculated using the following equation

$$L = \frac{1}{f \cdot \Delta I_L} V_{OUT} \left(1 - \frac{V_{OUT}}{V_{IN}} \right)$$

Substituting $V_{OUT}=1.8V$, $V_{IN}=4.2V$, $\Delta I_L=180mA$ to 240mA (30% to 40%) and $f=1.3MHz$ gives

$$L = 2.86\mu H \text{ to } 3.81\mu H$$

A 3.3 μH inductor can be chosen with this application. An inductor of greater value with less equivalent series resistance would provide better efficiency. The CIN capacitor requires an RMS current rating of at least $I_{LOAD(MAX)}/2$ and low ESR. In most cases, a ceramic capacitor will satisfy this requirement.

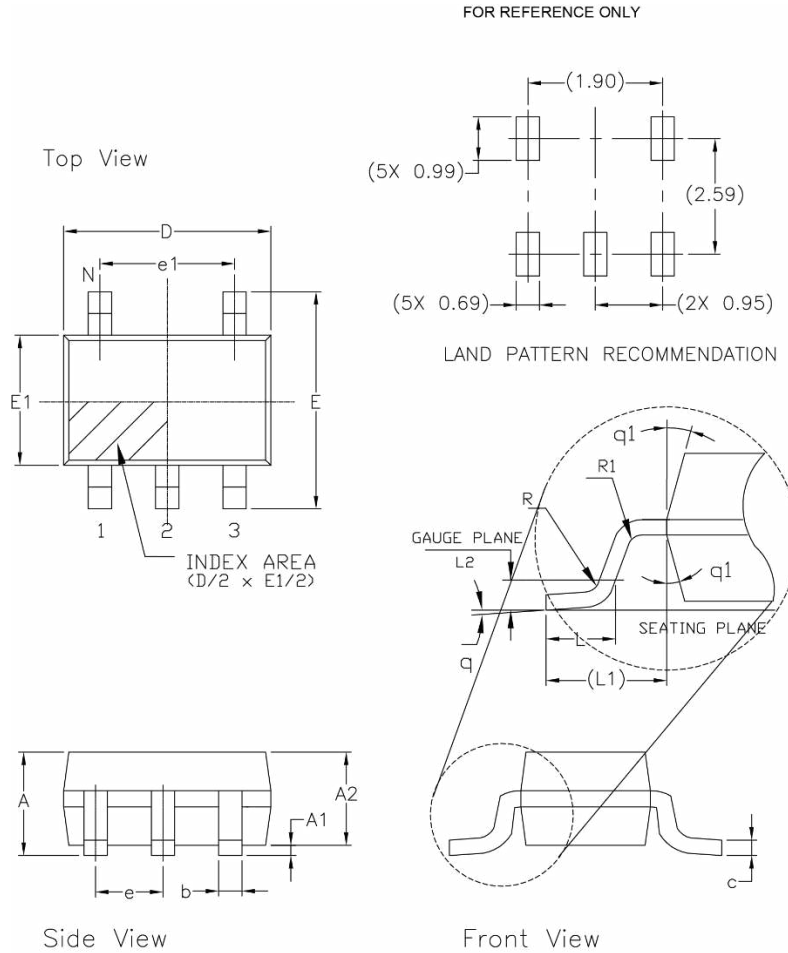
MECHANICAL DIMENSIONS
5-PIN SOT23

5 Pin SOT-23 JEDEC MO-178 Variation AA						
SYMBOLS	DIMENSIONS IN MM (Control Unit)			DIMENSIONS IN INCH (Reference Unit)		
	MIN	NOM	MAX	MIN	NOM	MAX
A	—	—	1.45	—	—	0.057
A1	0.00	—	0.15	0.000	—	0.006
A2	0.90	1.15	1.30	0.036	0.045	0.051
b	0.30	—	0.50	0.012	—	0.020
c	0.08	—	0.22	0.003	—	0.009
D	2.90 BSC			0.115 BSC		
E	2.80 BSC			0.111 BSC		
E1	1.60 BSC			0.063 BSC		
e	0.95 BSC			0.038 BSC		
e1	1.90 BSC			0.075 BSC		
L	0.30	0.45	0.60	0.012	0.018	0.024
L1	0.60 REF			0.024 REF		
L2	0.25 BSC			0.010 BSC		
R	0.10	—	—	0.004	—	—
R1	0.10	—	0.25	0.004	—	0.010
q	0'	4'	8'	0'	4'	8'
q1	5'	10'	15'	5'	10'	15'
N	5			5		

Drawing No: POD-0000025
Revision: B

**REVISION HISTORY**

Revision	Date	Description
2.0.0	07/15/2011	Reformat of datasheet Updated package specification
2.1.0	02/07/2012	Updated Typical Application schematics and Design example
2.2.0	11/08/2012	Reformat of datasheet (New logo) Updated Absolute Maximum Ratings, Lead Temperature (Soldering, 10 sec) to 260°C
2.2.1	05/13/2016	Reformat of datasheet (New logo) Changed oscillator frequency unit
3.0.0	12/07/2017	Updated I_{OUT} , V_{IN} range, thermal resistance, ΔV_{OUT} , V_{FB} temperature condition, I_{PK} , I_Q , f_{OSC} , $R_{DS(ON)}$, package drawing (now Mechanical Dimensions), format and Ordering Information. Added PSM and new graphs. Updated to MaxLinear logo. Removed fixed voltage options. New graphs.
4.0.0	01/07/2020	Updated I_{OUT} , V_{IN} range and V_{IN} absolute max, I_Q , I_{PK} , $R_{DS(ON)}$. Updated graphs. Updated ESD rating.
5.0.0	07/26/2021	Updated I_{OUT} , V_{IN} range and V_{IN} absolute max, I_Q , I_{PK} , $R_{DS(ON)}$. Updated graphs. Updated ESD rating. PCN 19011A (Addendum) cancels rev 4.0.0, therefore rev 5.0.0 is the same as rev 3.0.0.

**Corporate Headquarters:**

5966 La Place Court
Suite 100
Carlsbad, CA 92008
Tel.: +1 (760) 692-0711
Fax: +1 (760) 444-8598
www.maxlinear.com

The content of this document is furnished for informational use only, is subject to change without notice, and should not be construed as a commitment by MaxLinear, Inc.. MaxLinear, Inc. assumes no responsibility or liability for any errors or inaccuracies that may appear in the informational content contained in this guide. Complying with all applicable copyright laws is the responsibility of the user. Without limiting the rights under copyright, no part of this document may be reproduced into, stored in, or introduced into a retrieval system, or transmitted in any form or by any means (electronic, mechanical, photocopying, recording, or otherwise), or for any purpose, without the express written permission of MaxLinear, Inc.

MaxLinear, Inc. does not recommend the use of any of its products in life support applications where the failure or malfunction of the product can reasonably be expected to cause failure of the life support system or to significantly affect its safety or effectiveness. Products are not authorized for use in such applications unless MaxLinear, Inc. receives, in writing, assurances to its satisfaction that: (a) the risk of injury or damage has been minimized; (b) the user assumes all such risks; (c) potential liability of MaxLinear, Inc. is adequately protected under the circumstances.

MaxLinear, Inc. may have patents, patent applications, trademarks, copyrights, or other intellectual property rights covering subject matter in this document. Except as expressly provided in any written license agreement from MaxLinear, Inc., the furnishing of this document does not give you any license to these patents, trademarks, copyrights, or other intellectual property.

MaxLinear, the MaxLinear logo, any MaxLinear trademarks (MxL, Full-Spectrum Capture, FSC, G.now, AirPHY, Puma, and AnyWAN), and the MaxLinear logo on the products sold are all property of MaxLinear, Inc. or one of MaxLinear's subsidiaries in the U.S.A. and other countries. All rights reserved. Other company trademarks and product names appearing herein are the property of their respective owners.

© 2021 MaxLinear, Inc. All rights reserved.