

+3V to +5.5V, 1 Microamp, 250kbps, RS-232 Transmitter/Receiver

The Intersil ICL3310 contains 3.0V to 5.5V powered RS-232 transmitters/receivers which meet EIA/TIA-232 and V.28/V.24 specifications, even at V_{CC} = 3.0V. Targeted applications are PDAs, Palmtops, and notebook and laptop computers where the low operational, and even lower standby, power consumption is critical. Efficient on-chip charge pumps, coupled with a manual powerdown function reduces the standby supply current to a 1µA trickle. Small footprint packaging, and the use of small, low value capacitors ensure board space savings as well. Data rates greater than 250kbps are guaranteed at worst case load conditions. This device is fully compatible with 3.3V only systems, mixed 3.3V and 5.0V systems, and 5.0V only systems.

The single pin powerdown function ($\overline{\text{SHDN}} = 0$) disables all the transmitters and receivers, while shutting down the charge pump to minimize supply current drain.

Table 1 summarizes the features of the ICL3310, while Application Note AN9863 summarizes the features of each device comprising the ICL32XX 3V family.

Pinout

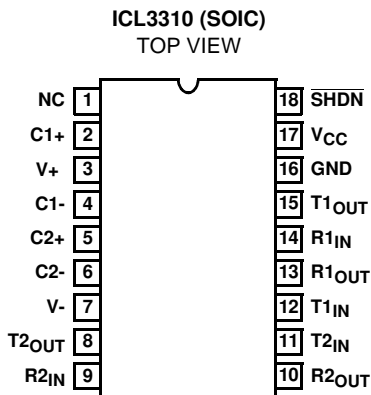

Features

- ±15kV ESD Protected (Human Body Model)
- Low Power, Pin Compatible Upgrade for 5V MAX222, SP310A, and LT1X80/A
- Single $\overline{\text{SHDN}}$ Pin Disables Transmitters and Receivers
- Meets EIA/TIA-232 and V.28/V.24 Specifications at 3V
- Latch-Up Free
- On-Chip Voltage Converters Require Only Four External 0.1µF Capacitors
- Receiver Hysteresis For Improved Noise Immunity
- Very Low Supply Current 0.3mA
- Guaranteed Minimum Data Rate 250kbps
- Guaranteed Minimum Slew Rate 6V/µs
- Wide Power Supply Range Single +3V to +5.5V
- Low Supply Current in Powerdown State. <1µA

Applications

- Any System Requiring RS-232 Communication Ports
 - Battery Powered, Hand-Held, and Portable Equipment
 - Laptop Computers, Notebooks, Palmtops
 - Modems, Printers and other Peripherals
 - Digital Cameras
 - Cellular/Mobile Phones

Related Literature

- Technical Brief TB363 "Guidelines for Handling and Processing Moisture Sensitive Surface Mount Devices (SMDs)"

Part # Information

PART NO.	TEMP. RANGE (°C)	PACKAGE	PKG. NO.
ICL3310CB	0 to 70	18 Ld SOIC	M18.3
ICL3310CB-T	0 to 70	Tape and Reel	M18.3
ICL3310IB	-40 to 85	18 Ld SOIC	M18.3
ICL3310IB-T	-40 to 85	Tape and Reel	M18.3

TABLE 1. SUMMARY OF FEATURES

PART NUMBER	NO. OF Tx.	NO. OF Rx.	NO. OF MONITOR Rx. (R _{OUTB})	DATA RATE (kbps)	Rx. ENABLE FUNCTION?	READY OUTPUT?	MANUAL POWER-DOWN?	AUTOMATIC POWERDOWN FUNCTION?
ICL3310	2	2	0	250	NO	NO	YES	NO

Pin Descriptions

PIN	FUNCTION
V _{CC}	System power supply input (3.0V to 5.5V).
V+	Internally generated positive transmitter supply (+5.5V).
V-	Internally generated negative transmitter supply (-5.5V).
GND	Ground connection.
C1+	External capacitor (voltage doubler) is connected to this lead.
C1-	External capacitor (voltage doubler) is connected to this lead.
C2+	External capacitor (voltage inverter) is connected to this lead.
C2-	External capacitor (voltage inverter) is connected to this lead.
T _{IN}	TTL/CMOS compatible transmitter Inputs.
T _{OUT}	RS-232 level (nominally ±5.5V) transmitter outputs.
R _{IN}	RS-232 compatible receiver inputs.
R _{OUT}	TTL/CMOS level receiver outputs.
$\overline{\text{SHDN}}$	Active low input to shut down transmitters, receivers, and on-board power supply, to place device in low power mode.

Typical Operating Circuits

ICL3310

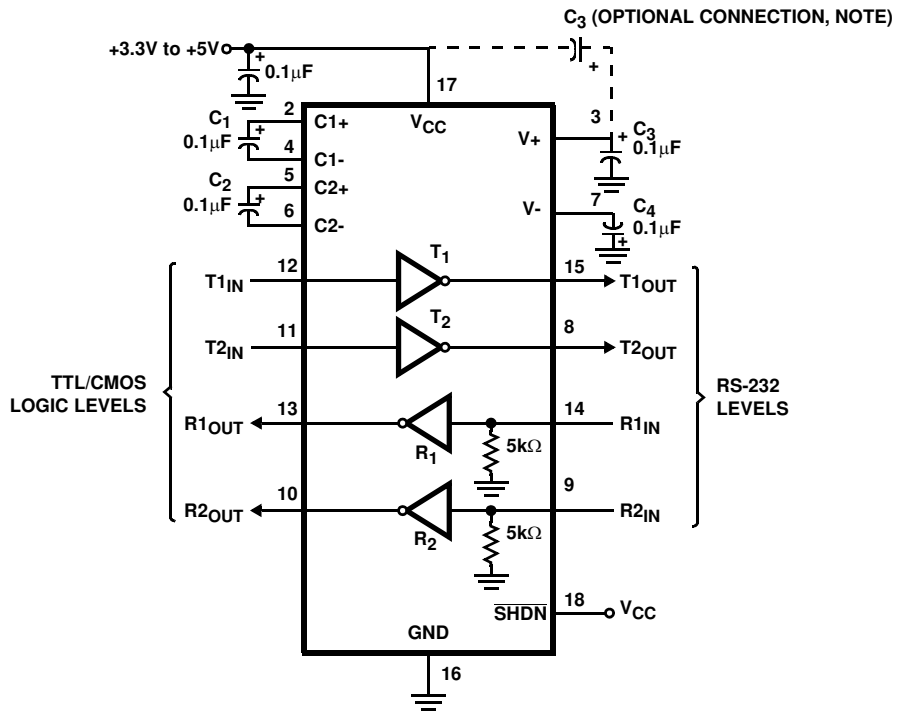

NOTE: The negative terminal of C₃ can be connected to either V_{CC} or GND.

Absolute Maximum Ratings

V _{CC} to Ground	-0.3V to 6V
V+ to Ground	-0.3V to 7V
V- to Ground	+0.3V to -7V
V+ to V-	14V
Input Voltages	
T _{IN} , $\overline{\text{SHDN}}$	-0.3V to 6V
R _{IN}	±25V
Output Voltages	
T _{OUT}	±13.2V
R _{OUT}	-0.3V to V _{CC} +0.3V
Short Circuit Duration	
T _{OUT}	Continuous
ESD Rating	See Specification Table

Thermal Information

Thermal Resistance (Typical, Note 1)	θ _{JA} (°C/W)
18 Ld SOIC Package	75
Maximum Junction Temperature (Plastic Package)	150°C
Maximum Storage Temperature Range	-65°C to 150°C
Maximum Lead Temperature (Soldering 10s) (Lead Tips Only)	300°C

Operating Conditions

ICL3310CX	0°C to 70°C
ICL3310IX	-40°C to 85°C

CAUTION: Stresses above those listed in "Absolute Maximum Ratings" may cause permanent damage to the device. This is a stress only rating and operation of the device at these or any other conditions above those indicated in the operational sections of this specification is not implied.

NOTE:

1. θ_{JA} is measured with the component mounted on a low effective thermal conductivity test board in free air. See Tech Brief TB379 for details.

Electrical Specifications Test Conditions: V_{CC} = 3V to 5.5V, C₁ - C₄ = 0.1µF; Unless Otherwise Specified.
Typicals are at T_A = 25°C

PARAMETER	TEST CONDITIONS	TEMP (°C)	MIN	TYP	MAX	UNITS
DC CHARACTERISTICS						
Supply Current, Powerdown	$\overline{\text{SHDN}} = \text{GND}$	25	-	0.1	10	µA
		Full	-	-	50	µA
Supply Current, Enabled	All Outputs Unloaded, $\overline{\text{SHDN}} = V_{CC}$, V _{CC} = 3.15V	Full	-	0.3	3.0	mA
LOGIC AND TRANSMITTER INPUTS AND RECEIVER OUTPUTS						
Input Logic Threshold Low	T _{IN} , $\overline{\text{SHDN}}$	Full	-	-	0.8	V
Input Logic Threshold High	T _{IN} , $\overline{\text{SHDN}}$	Full	2.4	-	-	V
Input Leakage Current	T _{IN} , $\overline{\text{SHDN}}$	Full	-	±0.01	±1.0	µA
Output Leakage Current	$\overline{\text{SHDN}} = V_{CC}$	Full	-	±0.05	±10	µA
Output Voltage Low	I _{OUT} = 3.2mA	Full	-	-	0.4	V
Output Voltage High	I _{OUT} = -1.0mA	Full	V _{CC} -0.6	V _{CC} -0.1	-	V
RECEIVER INPUTS						
Input Voltage Range		Full	-25	-	25	V
Input Threshold Low	V _{CC} = 3.3V	25	0.6	1.2	-	V
	V _{CC} = 5.0V	Full	0.8	1.5	-	V
Input Threshold High	V _{CC} = 3.3V	25	-	1.5	2.4	V
	V _{CC} = 5.0V	Full	-	1.8	2.4	V
Input Hysteresis		Full	0.2	0.5	1	V
Input Resistance		Full	3	5	7	kΩ
TRANSMITTER OUTPUTS						
Output Voltage Swing	All Transmitter Outputs Loaded with 3kΩ to Ground	Full	±5.0	±5.4	-	V
Output Resistance	V _{CC} = V+ = V- = 0V, Transmitter Output = ±2V	Full	300	10M	-	Ω
Output Short-Circuit Current		Full	±7	±35	-	mA
Output Leakage Current	V _{OUT} = ±12V, V _{CC} = 0V or 3V to 5.5V, $\overline{\text{SHDN}} = \text{GND}$	Full	-	-	±10	µA

ICL3310

Electrical Specifications

Test Conditions: $V_{CC} = 3V$ to $5.5V$, $C_1 - C_4 = 0.1\mu F$; Unless Otherwise Specified.
Typicals are at $T_A = 25^\circ C$ (Continued)

PARAMETER	TEST CONDITIONS	TEMP (°C)	MIN	TYP	MAX	UNITS	
TIMING CHARACTERISTICS							
Maximum Data Rate	$R_L = 3k\Omega$, $C_L = 1000pF$, One Transmitter Switching	Full	250	500	-	kbps	
Transmitter Propagation Delay	Transmitter Input to Transmitter Output, $C_L = 1000pF$	t_{PHL}	Full	-	0.6	3.5	μs
		t_{PLH}	Full	-	0.7	3.5	μs
Receiver Propagation Delay	Receiver Input to Receiver Output, $C_L = 150pF$	t_{PHL}	Full	-	0.2	1	μs
		t_{PLH}	Full	-	0.3	1	μs
Transmitter Output Enable Time	From \overline{SHDN} Rising Edge to $T_{OUT} = \pm 3V$	25	-	50	-	μs	
Transmitter Output Disable Time	From \overline{SHDN} Falling Edge to $T_{OUT} = \pm 5V$	25	-	600	-	ns	
Transmitter Skew	$t_{PHL} - t_{PLH}$ (Note 2)	25	-	100	-	ns	
Receiver Skew	$t_{PHL} - t_{PLH}$	25	-	100	-	ns	
Transition Region Slew Rate	$R_L = 3k\Omega$ to $7k\Omega$, Measured From $3V$ to $-3V$ or $-3V$ to $3V$	$V_{CC} = 3.3V$, $C_L = 150pF$ to $2500pF$	25	4	-	-	$V/\mu s$
		$V_{CC} = 4.5V$, $C_L = 150pF$ to $2500pF$	25	6	-	-	$V/\mu s$
ESD PERFORMANCE							
RS-232 Pins (T_{OUT} , R_{IN})	Human Body Model	25	-	± 15	-	kV	
	IEC1000-4-2 Contact Discharge	25	-	± 8	-	kV	
	IEC1000-4-2 Air Gap Discharge	25	-	$> \pm 8$	-	kV	
All Other Pins	Human Body Model	25	-	± 3	-	kV	

NOTE:

- Transmitter skew is measured at the transmitter zero crossing points.

Detailed Description

ICL3310 interface ICs operate from a single +3V to +5.5V supply, guarantee a 250kbps minimum data rate, require only four small external $0.1\mu F$ capacitors, feature low power consumption, and meet all EIA RS-232C and V.28 specifications. The circuit is divided into three sections: The charge pump, the transmitters, and the receivers.

Charge-Pump

Intersil's new ICL3310 utilizes regulated on-chip dual charge pumps as voltage doublers, and voltage inverters to generate $\pm 5.5V$ transmitter supplies from a V_{CC} supply as low as $3.0V$. This allows these devices to maintain RS-232 compliant output levels over the $\pm 10\%$ tolerance range of $3.3V$ powered systems. The efficient on-chip power supplies require only four small, external $0.1\mu F$ capacitors for the voltage doubler and inverter functions at $V_{CC} = 3.3V$. See the "Capacitor Selection" section, and Table 3 for capacitor recommendations for other operating conditions. The charge pumps operate discontinuously (i.e., they turn off as soon as the $V+$ and $V-$ supplies are pumped up to the nominal values), resulting in significant power savings.

Transmitters

The transmitters are proprietary, low dropout, inverting drivers that translate TTL/CMOS inputs to EIA/TIA-232 output levels. Coupled with the on-chip $\pm 5.5V$ supplies, these transmitters deliver true RS-232 levels over a wide range of single supply system voltages.

All transmitter outputs disable and assume a high impedance state when the device enters the powerdown mode (see Table 2). These outputs may be driven to $\pm 12V$ when disabled.

All devices guarantee a 250kbps data rate for full load conditions ($3k\Omega$ and $1000pF$), $V_{CC} \geq 3.0V$, with one transmitter operating at full speed. Under more typical conditions of $V_{CC} \geq 3.3V$, $R_L = 3k\Omega$, and $C_L = 250pF$, one transmitter easily operates at 900kbps.

Transmitter inputs float if left unconnected (there are no pull-up resistors), and may cause I_{CC} increases. Connect unused inputs to GND for the best performance.

TABLE 2. POWERDOWN AND ENABLE LOGIC TRUTH TABLE

SHDN INPUT	TRANSMITTER OUTPUTS	RECEIVER OUTPUTS	MODE OF OPERATION
H	Active	Active	Normal Operation
L	High-Z	High-Z	Manual Powerdown

Receivers

The ICL3310 contains standard inverting receivers that three-state via the $\overline{\text{SHDN}}$ control line. Receivers driving powered down peripherals must be disabled to prevent current flow through the peripheral's protection diodes (see Figures 2 and 3).

All the receivers convert RS-232 signals to CMOS output levels and accept inputs up to $\pm 30\text{V}$ while presenting the required $3\text{k}\Omega$ to $7\text{k}\Omega$ input impedance (see Figure 1) even if the power is off ($V_{CC} = 0\text{V}$). The receivers' Schmitt trigger input stage uses hysteresis to increase noise immunity and decrease errors due to slow input signal transitions.

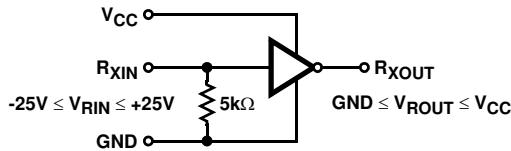

FIGURE 1. INVERTING RECEIVER CONNECTIONS

Low Power Operation

This 3V device requires a nominal supply current of 0.3mA, even at $V_{CC} = 5.5\text{V}$, during normal operation (not in powerdown mode). This is considerably less than the 11mA current required by comparable 5V RS-232 devices, allowing users to reduce system power simply by replacing the old style device with the ICL3310.

Low Power, Pin Compatible Replacement

Pin compatibility with existing 5V products (e.g., MAX222), coupled with the wide operating supply range, make the ICL3310 a potential lower power, higher performance drop-in replacement for existing 5V applications. As long as the $\pm 5\text{V}$ RS-232 output swings are acceptable, and transmitter pull-up resistors aren't required, the ICL3310 should work in most 5V applications.

When replacing a device in an existing 5V application, it is acceptable to terminate C_3 to V_{CC} as shown on the "Typical Operating Circuit". Nevertheless, terminate C_3 to GND if possible, as slightly better performance results from this configuration.

Powerdown Functionality

The already low current requirement drops significantly when the device enters powerdown mode. In powerdown, supply current drops to $1\mu\text{A}$, because the on-chip charge pump turns off (V_+ collapses to V_{CC} , V_- collapses to GND), and the transmitter and receiver outputs three-state. This micro-power mode makes these devices ideal for battery powered and portable applications.

Software Controlled (Manual) Powerdown

The ICL3310 may be forced into its low power, standby state via a simple shutdown ($\overline{\text{SHDN}}$) pin (see Figure 4). Driving this pin high enables normal operation, while driving it low forces the IC into its powerdown state. The time required to exit powerdown, and resume transmission is less than $50\mu\text{s}$. Connect $\overline{\text{SHDN}}$ to V_{CC} if the powerdown function isn't needed.

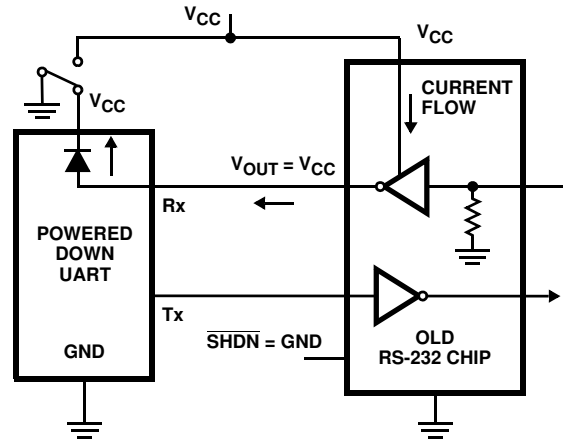

FIGURE 2. POWER DRAIN THROUGH POWERED DOWN PERIPHERAL

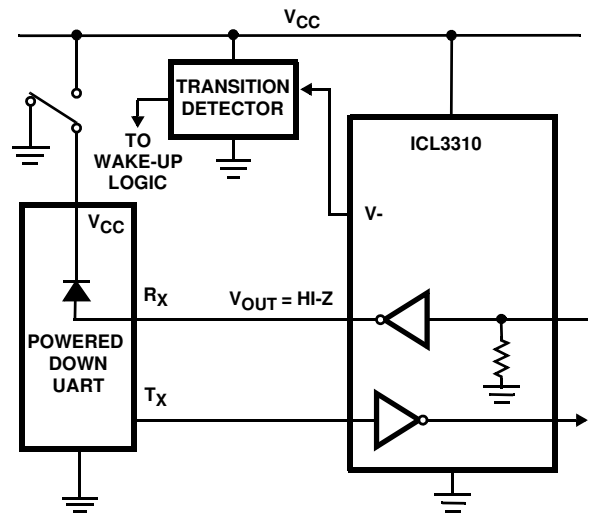

FIGURE 3. DISABLED RECEIVERS PREVENT POWER DRAIN

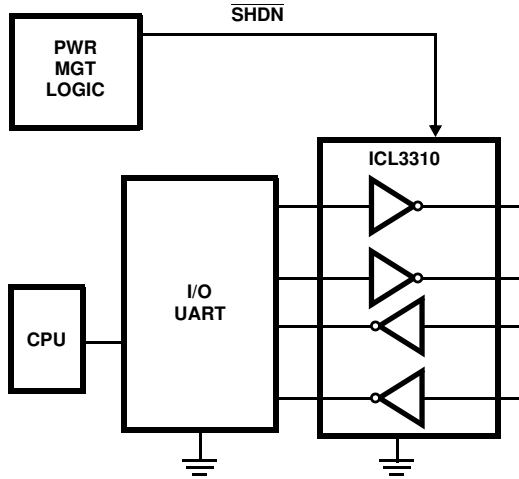

FIGURE 4. CONNECTIONS FOR MANUAL POWERDOWN

Capacitor Selection

The charge pumps require 0.1µF or greater capacitors for operation with $3.3V \leq V_{CC} \leq 5.5V$. Increasing the capacitor values (by a factor of 2) reduces ripple on the transmitter outputs and slightly reduces power consumption. C_2 , C_3 , and C_4 can be increased without increasing C_1 's value, however, do not increase C_1 without also increasing C_2 , C_3 , and C_4 to maintain the proper ratios (C_1 to the other capacitors).

When using minimum required capacitor values, make sure that capacitor values do not degrade excessively with temperature. If in doubt, use capacitors with a larger nominal value. The capacitor's equivalent series resistance (ESR) usually rises at low temperatures and it influences the amount of ripple on $V+$ and $V-$.

Power Supply Decoupling

In most circumstances a 0.1µF bypass capacitor is adequate. In applications that are particularly sensitive to power supply noise, decouple V_{CC} to ground with a capacitor of the same value as the charge-pump capacitor C_1 . Connect the bypass capacitor as close as possible to the IC.

Transmitter Outputs when Exiting Powerdown

Figure 5 shows the response of two transmitter outputs when exiting powerdown mode. As they activate, the two transmitter outputs properly go to opposite RS-232 levels, with no glitching, ringing, nor undesirable transients. Each transmitter is loaded with 3kΩ in parallel with 2500pF. Note that the transmitters enable only when the magnitude of the supplies exceed approximately 3V.

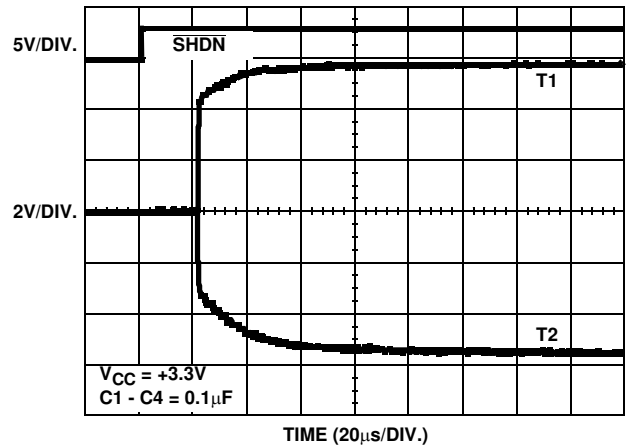

FIGURE 5. TRANSMITTER OUTPUTS WHEN EXITING POWERDOWN

High Data Rates

The ICL3310 maintain the RS-232 ±5V minimum transmitter output voltages even at high data rates. Figure 6 details a transmitter loopback test circuit, and Figure 7 illustrates the loopback test result at 120kbps. For this test, all transmitters were simultaneously driving RS-232 loads in parallel with 1000pF, at 120kbps. Figure 8 shows the loopback results for a single transmitter driving 1000pF and an RS-232 load at 250kbps. The static transmitters were also loaded with an RS-232 receiver.

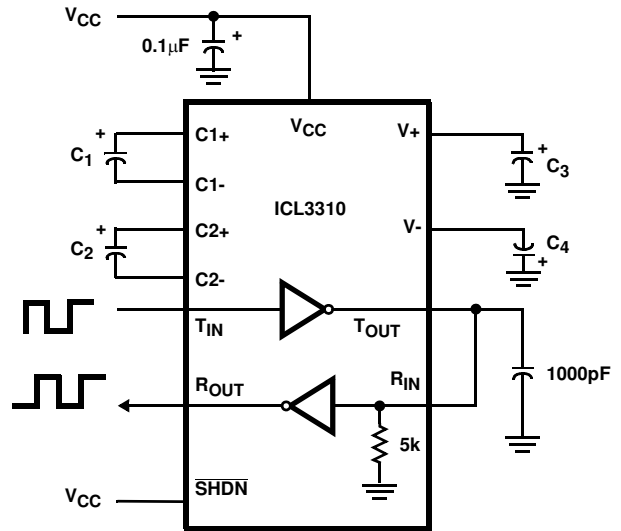

FIGURE 6. TRANSMITTER LOOPBACK TEST CIRCUIT

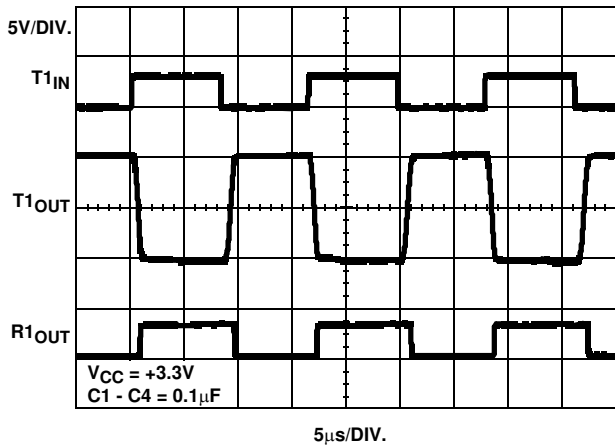

FIGURE 7. LOOPBACK TEST AT 120kbps

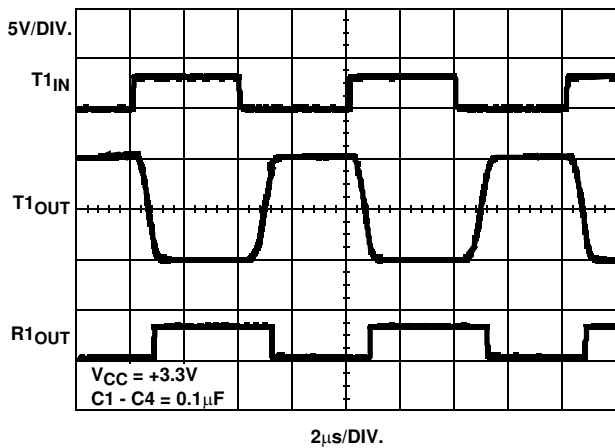

FIGURE 8. LOOPBACK TEST AT 250kbps

Interconnection with 3V and 5V Logic

The ICL3310 directly interface with most 5V logic families, including ACT and HCT CMOS. See Table 3 for more information on possible combinations of interconnections.

TABLE 3. LOGIC FAMILY COMPATIBILITY WITH VARIOUS SUPPLY VOLTAGES

SYSTEM POWER-SUPPLY VOLTAGE (V)	V _{CC} SUPPLY VOLTAGE (V)	COMPATIBILITY
3.3	3.3	Compatible with all CMOS families.
5	5	Compatible with all TTL and CMOS logic families.
5	3.3	Compatible with ACT and HCT CMOS, and with TTL. Incompatible with AC, HC, or CD4000 CMOS.

Typical Performance Curves $V_{CC} = 3.3V, T_A = 25^{\circ}C$

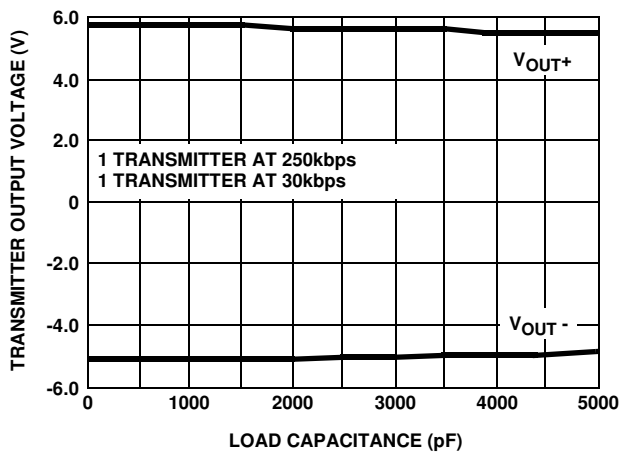

FIGURE 9. TRANSMITTER OUTPUT VOLTAGE vs LOAD CAPACITANCE

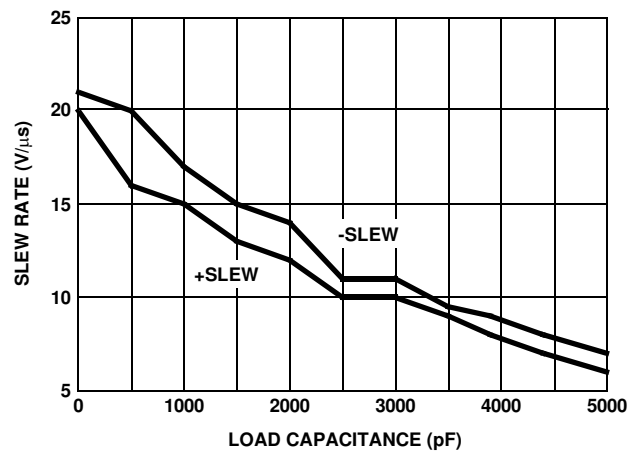

FIGURE 10. SLEW RATE vs LOAD CAPACITANCE

Typical Performance Curves $V_{CC} = 3.3V, T_A = 25^{\circ}C$ (Continued)

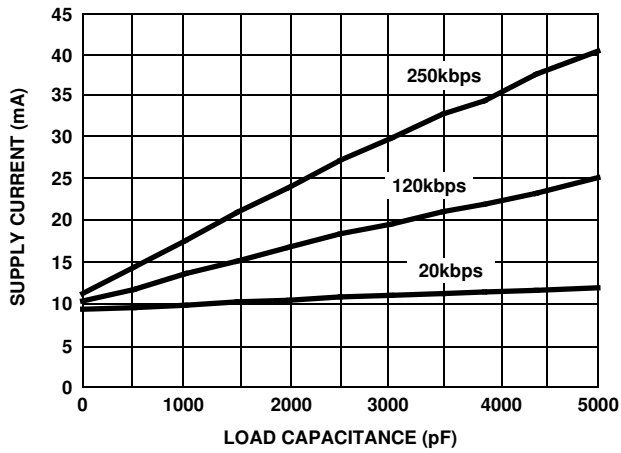

FIGURE 11. SUPPLY CURRENT vs LOAD CAPACITANCE WHEN TRANSMITTING DATA

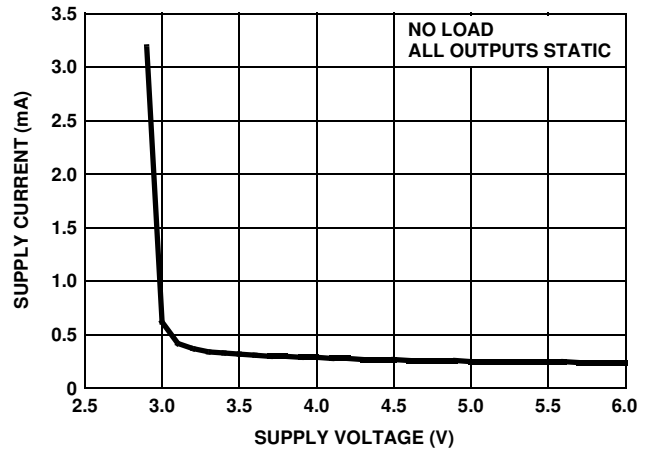

FIGURE 12. SUPPLY CURRENT vs SUPPLY VOLTAGE

Die Characteristics

SUBSTRATE POTENTIAL (POWERED UP):

GND

TRANSISTOR COUNT:

338

PROCESS:

Si Gate CMOS

Small Outline Plastic Packages (SOIC)

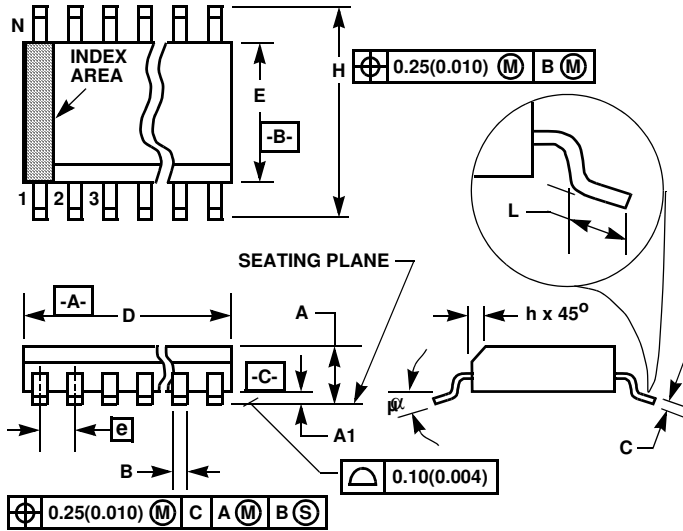

M18.3 (JEDEC MS-013-AB ISSUE C)
18 LEAD WIDE BODY SMALL OUTLINE PLASTIC PACKAGE

SYMBOL	INCHES		MILLIMETERS		NOTES
	MIN	MAX	MIN	MAX	
A	0.0926	0.1043	2.35	2.65	-
A1	0.0040	0.0118	0.10	0.30	-
B	0.013	0.0200	0.33	0.51	9
C	0.0091	0.0125	0.23	0.32	-
D	0.4469	0.4625	11.35	11.75	3
E	0.2914	0.2992	7.40	7.60	4
e	0.050 BSC		1.27 BSC		-
H	0.394	0.419	10.00	10.65	-
h	0.010	0.029	0.25	0.75	5
L	0.016	0.050	0.40	1.27	6
N	18		18		7
α	0°	8°	0°	8°	-

NOTES:

1. Symbols are defined in the "MO Series Symbol List" in Section 2.2 of Publication Number 95.
2. Dimensioning and tolerancing per ANSI Y14.5M-1982.
3. Dimension "D" does not include mold flash, protrusions or gate burrs. Mold flash, protrusion and gate burrs shall not exceed 0.15mm (0.006 inch) per side.
4. Dimension "E" does not include interlead flash or protrusions. Interlead flash and protrusions shall not exceed 0.25mm (0.010 inch) per side.
5. The chamfer on the body is optional. If it is not present, a visual index feature must be located within the crosshatched area.
6. "L" is the length of terminal for soldering to a substrate.
7. "N" is the number of terminal positions.
8. Terminal numbers are shown for reference only.
9. The lead width "B", as measured 0.36mm (0.014 inch) or greater above the seating plane, shall not exceed a maximum value of 0.61mm (0.024 inch)
10. Controlling dimension: MILLIMETER. Converted inch dimensions are not necessarily exact.

Rev. 0 12/93

All Intersil U.S. products are manufactured, assembled and tested utilizing ISO9000 quality systems. Intersil Corporation's quality certifications can be viewed at www.intersil.com/design/quality

Intersil products are sold by description only. Intersil Corporation reserves the right to make changes in circuit design, software and/or specifications at any time without notice. Accordingly, the reader is cautioned to verify that data sheets are current before placing orders. Information furnished by Intersil is believed to be accurate and reliable. However, no responsibility is assumed by Intersil or its subsidiaries for its use; nor for any infringements of patents or other rights of third parties which may result from its use. No license is granted by implication or otherwise under any patent or patent rights of Intersil or its subsidiaries.

For information regarding Intersil Corporation and its products, see www.intersil.com