

## Low Noise, Wideband Precision Operational Amplifiers

March 1993

### Features

- Gain Bandwidth Product ..... 100MHz
- Unity Gain Bandwidth ..... 35MHz
- High Slew Rate ..... 35V/μs
- Low Offset Voltage ..... 0.3mV
- High Open Loop Gain ..... 128dB
- Channel Separation at 10kHz ..... 110dB
- Low Noise Voltage at 1kHz ..... 3.4nV/√Hz
- High Output Current ..... 56mA
- Low Supply Current per Amplifier ..... 8mA

### Applications

- Precision Test Systems
- Active Filtering
- Small Signal Video
- Accurate Signal Processing
- RF Signal Conditioning

### Description

The HA-5221/5222 are single and dual high performance dielectrically isolated, monolithic op amps, featuring precision DC characteristics while providing excellent AC characteristics. Designed for audio, video, and other demanding applications, noise (3.4nV/√Hz at 1kHz), total harmonic distortion (< 0.005%), and DC errors are kept to a minimum.

The precision performance is shown by low offset voltage (0.3mV), low bias currents (40nA), low offset currents (15nA), and high open loop gain (128dB). The combination of these excellent DC characteristics with the fast settling time (0.4μs) make the HA-5221/5222 ideally suited for precision signal conditioning.

The unique design of the HA-5221/5222 gives them outstanding AC characteristics not normally associated with precision op amps, high unity gain bandwidth (35MHz) and high slew rate (35V/μs). Other key specifications include high CMRR (95dB) and high PSRR (100dB). The combination of these specifications will allow the HA-5221/5222 to be used in RF signal conditioning as well as video amplifiers.

For MIL-STD-883C compliant product and Ceramic LCC packaging, consult the HA-5221/5222/883C data sheet.

### Pinouts (See Ordering Information on Next Page)

HA-5221 (PDIP, CDIP, SOIC)  
TOP VIEW

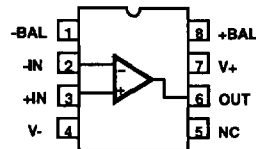

HA-5221 (TO-99 METAL CAN)  
TOP VIEW

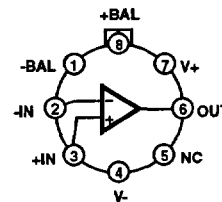

HA-5222 (PDIP, 300 mil SOIC)  
TOP VIEW

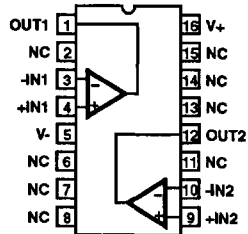

HA-5222 (CDIP)  
TOP VIEW

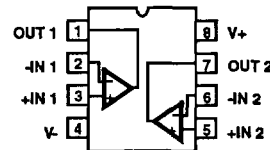

CAUTION: These devices are sensitive to electrostatic discharge. Users should follow proper I.C. Handling Procedures.  
Copyright © Harris Corporation 1993

File Number 2915.1

## HA-5221, HA-5222

### Ordering Information

PART NUMBER	TEMPERATURE RANGE	PACKAGE
HA2-5221-5	0°C to +75°C	8 Lead CAN
HA2-5221-9	-40°C to +85°C	8 Lead CAN
HA3-5221-5	0°C to +75°C	8 Lead Plastic DIP
HA7-5221-5	0°C to +75°C	8 Lead Ceramic DIP
HA7-5221-9	-40°C to +85°C	8 Lead Ceramic DIP
HA9P5221-5	0°C to +75°C	8 Lead SOIC

PART NUMBER	TEMPERATURE RANGE	PACKAGE
HA3-5222-5	0°C to +75°C	16 Lead Plastic DIP
HA3-5222-9	-40°C to +85°C	16 Lead Plastic DIP
HA7-5222-5	0°C to +75°C	8 Lead Ceramic DIP
HA7-5222-9	-40°C to +85°C	8 Lead Ceramic DIP
HA9P5222-5	0°C to +75°C	16 Lead Wide Body SOIC
HA9P5222-9	-40°C to +85°C	16 Lead Wide Body SOIC

2

OPERATIONAL  
AMPLIFIERS

## Specifications HA-5221, HA-5222

### Absolute Maximum Ratings (Note 1)

Supply Voltage Between V+ and V- Terminals .....	35V
Differential Input Voltage (Note 14) .....	5V
Output Current Short Circuit Duration .....	Indefinite
Junction Temperature .....	+175°C
Junction Temperature (Plastic Package) .....	+150°C
Lead Temperature (Soldering 10 Sec.) .....	+300°C

### Operating Conditions

Operating Temperature Range	HA-5221/5222-9 .....	$-40^{\circ}\text{C} \leq T_A \leq +85^{\circ}\text{C}$
	HA-5221/5222-5 .....	$0^{\circ}\text{C} \leq T_A \leq +75^{\circ}\text{C}$
Storage Temperature Range .....		$-65^{\circ}\text{C} \leq T_A \leq +150^{\circ}\text{C}$

**CAUTION:** Stresses above those listed in "Absolute Maximum Ratings" may cause permanent damage to the device. This is a stress only rating and operation of the device at these or any other conditions above those indicated in the operational sections of this specification is not implied.

### Electrical Specifications $V_+ = 15\text{V}$ , $V_- = -15\text{V}$ , Unless Otherwise Specified

PARAMETER	TEMP	HA-5221-9 & HA-5222-9			HA-5221-5 & HA-5222-5			UNITS
		MIN	TYP	MAX	MIN	TYP	MAX	
<b>INPUT CHARACTERISTICS</b>								
Input Offset Voltage	+25°C	-	0.30	0.75	-	0.30	0.75	mV
	Full	-	0.35	1.5	-	0.35	1.5	mV
Average Offset Voltage Drift	Full	-	0.5	-	-	0.5	-	$\mu\text{V}/^{\circ}\text{C}$
Input Bias Current	+25°C	-	40	80	-	40	100	nA
	Full	-	70	200	-	70	200	nA
Input Offset Current	+25°C	-	15	50	-	15	100	nA
	Full	-	30	150	-	30	150	nA
Input Offset Voltage Match	+25°C	-	400	750	-	400	750	$\mu\text{V}$
	Full	-	-	1500	-	-	1500	$\mu\text{V}$
Common Mode Range	+25°C	$\pm 12$	-	-	$\pm 12$	-	-	V
Differential Input Resistance	+25°C	-	70	-	-	70	-	k $\Omega$
Input Noise Voltage $f_o = 0.1\text{Hz to }10\text{Hz}$	+25°C	-	0.25	-	-	0.25	-	$\mu\text{Vp-p}$
Input Noise Voltage $f_o = 10\text{Hz}$	+25°C	-	6.2	10	-	6.2	10	$\text{nV}/\sqrt{\text{Hz}}$
Density (Note 2, 15) $f_o = 100\text{Hz}$	+25°C	-	3.6	6	-	3.6	6	$\text{nV}/\sqrt{\text{Hz}}$
	+25°C	-	3.4	4.0	-	3.4	4.0	$\text{nV}/\sqrt{\text{Hz}}$
Input Noise Current $f_o = 10\text{Hz}$	+25°C	-	4.7	8.0	-	4.7	8.0	$\text{pA}/\sqrt{\text{Hz}}$
	+25°C	-	0.97	1.8	-	0.97	1.8	$\text{pA}/\sqrt{\text{Hz}}$
Density (Note 2, 15) $f_o = 100\text{Hz}$	+25°C	-	1.8	2.8	-	1.8	2.8	$\text{pA}/\sqrt{\text{Hz}}$
Density (Note 2, 15) $f_o = 1000\text{Hz}$	+25°C	-	0.97	1.8	-	0.97	1.8	$\text{pA}/\sqrt{\text{Hz}}$
THD+N (Note 3)	+25°C	-	<0.005	-	-	<0.005	-	%
<b>TRANSFER CHARACTERISTICS</b>								
Large Signal Voltage Gain (Note 4)	+25°C	106	128	-	106	128	-	dB
	Full	100	120	-	100	120	-	dB
Common Mode Rejection Ratio (Note 5)	Full	86	95	-	86	95	-	dB
Unity Gain Bandwidth (-3dB)	+25°C	-	35	-	-	35	-	MHz

**Specifications HA-5221, HA-5222**

**Electrical Specifications**  $V_+ = 15V, V_- = -15V$ , Unless Otherwise Specified (Continued)

PARAMETER	TEMP	HA-5221-9 & HA-5222-9			HA-5221-5 & HA-5222-5			UNITS
		MIN	TYP	MAX	MIN	TYP	MAX	
Gain Bandwidth Product (1kHz to 400kHz)	+25°C	-	100	-	-	100	-	MHz
Minimum Stable Gain	Full	1	-	-	1	-	-	V/V
<b>OUTPUT CHARACTERISTICS</b>								
Output Voltage Swing								
$R_L = 333\Omega$	Full	$\pm 10$	-	-	$\pm 10$	-	-	V
$R_L = 1k\Omega$	+25°C	$\pm 12$	$\pm 12.5$	-	$\pm 12$	$\pm 12.5$	-	V
$R_L = 1k\Omega$	Full	$\pm 11.5$	$\pm 12.1$	-	$\pm 11.5$	$\pm 12.1$	-	V
Output Current (Note 6)	Full	$\pm 30$	$\pm 56$	-	$\pm 30$	$\pm 56$	-	mA
Output Resistance	+25°C	-	10	-	-	10	-	$\Omega$
Full Power Bandwidth (Note 7)	+25°C	398	557	-	398	557	-	kHz
Channel Separation (Note 8)	+25°C	-	110	-	-	110	-	dB
<b>TRANSIENT RESPONSE (Note 13)</b>								
Slew Rate (Note 9, 15)	Full	25	35	-	25	35	-	V/ $\mu$ s
Rise Time (Note 10, 15)	Full	-	13	20	-	13	20	ns
Overshoot (Note 10, 15)	Full	-	28	50	-	28	50	%
Settling Time (Note 11)								
0.1%	+25°C	-	0.4	-	-	0.4	-	$\mu$ s
0.01%	+25°C	-	1.5	-	-	1.5	-	$\mu$ s
<b>POWER SUPPLY</b>								
PSRR (Note 12)	Full	86	100	-	86	100	-	dB
Supply Current	Full	-	8	11	-	8	11	mA/Op Amp

**NOTES:**

- Absolute maximum ratings are limiting values, applied individually, beyond which the serviceability of the circuit may be impaired. Functional operation under any of these conditions is not necessarily implied.
- Refer to typical performance curve in data sheet.
- $A_{VCL} = 10, f_O = 1kHz, V_O = 5V_{rms}, R_L = 600\Omega, 10Hz$  to  $100kHz$ , Minimum resolution of test equipment is 0.005%.
- $V_{OUT} = 0$  to  $\pm 10V, R_L = 1K, C_L = 50pF$ .
- $V_{CM} = \pm 10V$ .
- $V_{OUT} = \pm 10V$ .
- Full Power Bandwidth is calculated by:  $FPBW = \frac{\text{Slew Rate}}{2\pi V_{Peak}}, V_{Peak} = 10V$
- HA-5222 only,  $f_O = 10kHz, R_L = 1K, C_L = 50pF$ .
- $V_{OUT} = \pm 2.5V, R_L = 1K, C_L = 50pF$ .
- $V_{OUT} = \pm 100mV, R_L = 1K, C_L = 50pF$ .
- Settling time is specified for a 10V step and  $A_V = -1$ .
- $V_S = \pm 10V$  to  $\pm 20V$ .
- See Test Circuits.
- Input is protected by back-to-back zener diodes. See applications section.
- Guaranteed by characterization.

**2**

**OPERATIONAL  
AMPLIFIERS**

Schematic Diagram

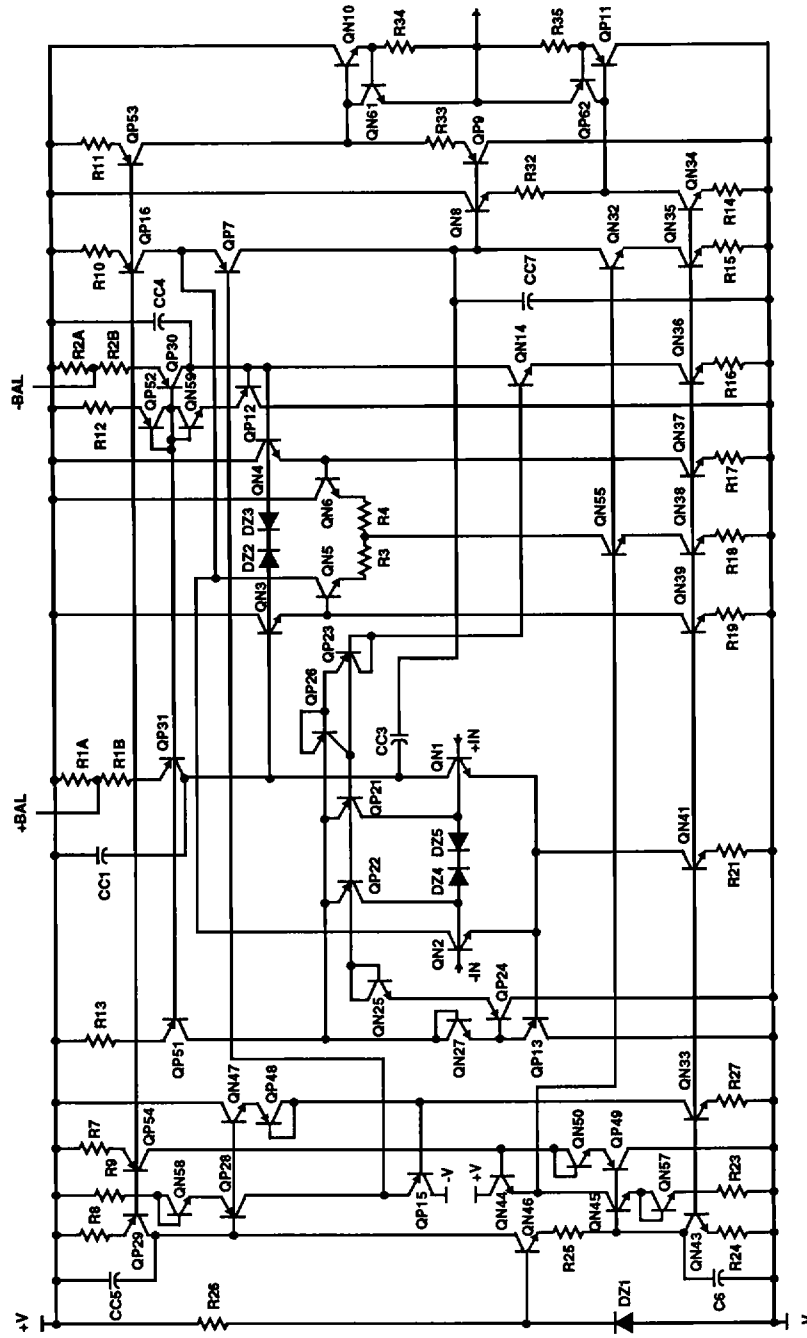

**Die Characteristics**

Transistor Count		Thermal Constants (°C/W)	$\theta_{JA}$	$\theta_{JC}$
HA-5221	64	HA2-5221 (Can)	111	35
HA-5222	128	HA7-5221 (Ceramic DIP)	114	34
Die Dimensions		HA7-5222 (Ceramic DIP)	112	32
HA-5221	94 x 72 x 19mils (2400 x 1840 x 480 $\mu$ m)	HA3-5221 (Plastic DIP)	92	30
		HA9P5221 (SOIC)	157	42
HA-5222	185 x 78 x 19mils (4690 x 1980 x 480 $\mu$ m)	HA3-5222 (Plastic DIP)	85	23
		HA9P5222 (SOIC)	95	26
Substrate Potential*	V-	* The substrate may be left floating (Insulating Die Mount) or it may be on a conductor at V- potential.		
Process	High Frequency, Bipolar, DI			
Passivation	Silox			

**Test Circuits**

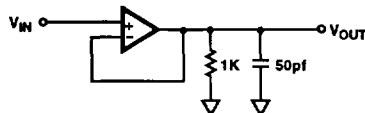

FIGURE 1. TRANSIENT RESPONSE TEST CIRCUIT

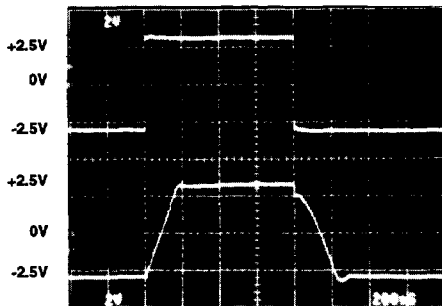

FIGURE 2. LARGE SIGNAL RESPONSE  
 $V_{OUT} = \pm 2.5V$   
 Vertical Scale: 2V/div., Horizontal Scale: 200ns/div.

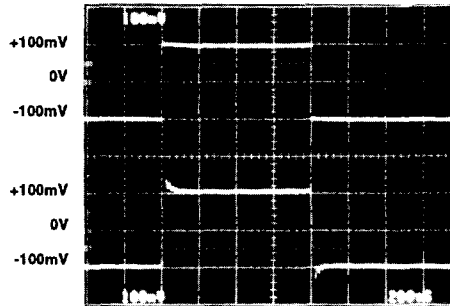

FIGURE 3. SMALL SIGNAL RESPONSE  
 $V_{OUT} = \pm 100mV$   
 Vertical Scale: 100mV/div., Horizontal Scale: 200ns/div.

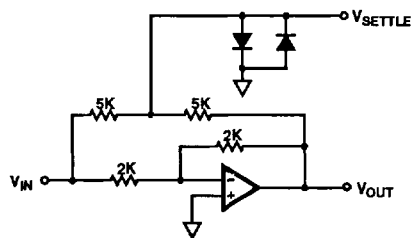

FIGURE 4. SETTLING TIME TEST CIRCUIT

- $AV = -1$
- Feedback and summing resistors must be matched (0.1%).
- HP5082-2810 clipping diodes recommended.
- Tektronix P6201 FET probe used at settling point.

Typical Performance Curves  $V_S = \pm 15V, T_A = +25^\circ C$

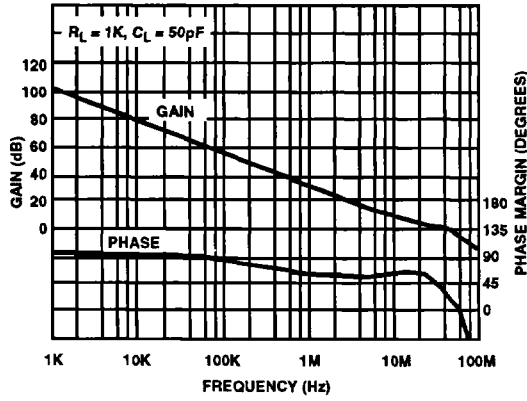

FIGURE 5. OPEN LOOP GAIN AND PHASE vs FREQUENCY

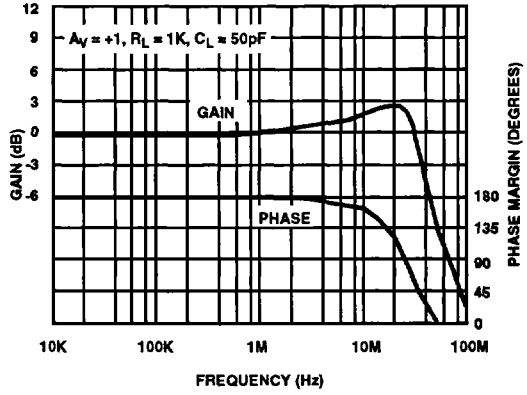

FIGURE 6. CLOSED LOOP GAIN vs FREQUENCY

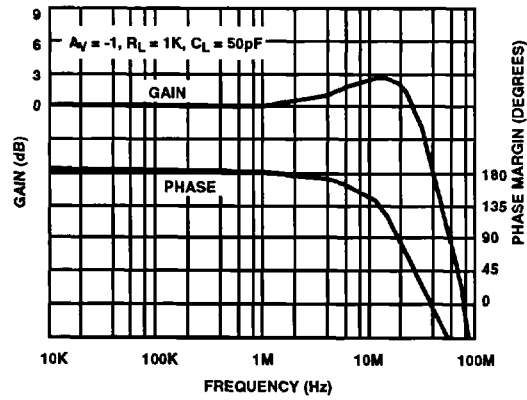

FIGURE 7. CLOSED LOOP GAIN vs FREQUENCY

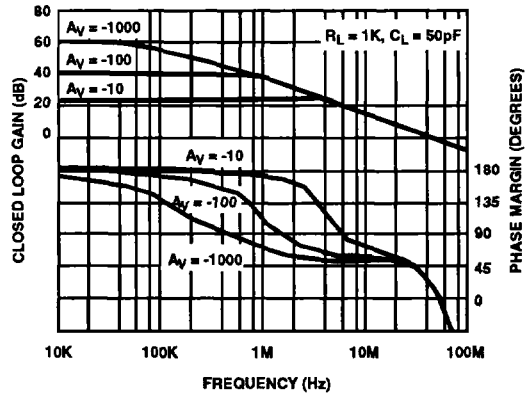

FIGURE 8. VARIOUS CLOSED LOOP GAINS vs FREQUENCY

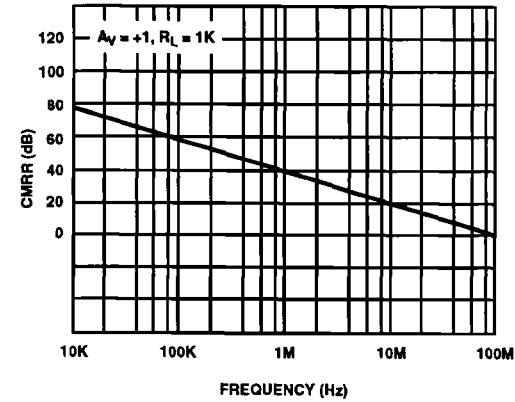

FIGURE 9. CMRR vs FREQUENCY

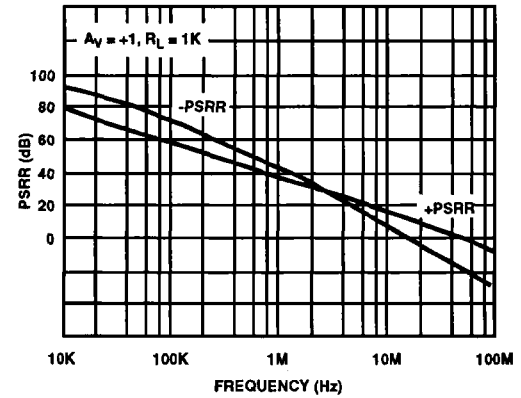

FIGURE 10. PSRR vs FREQUENCY

Typical Performance Curves  $V_S = \pm 15V, T_A = +25^\circ C$  (Continued)

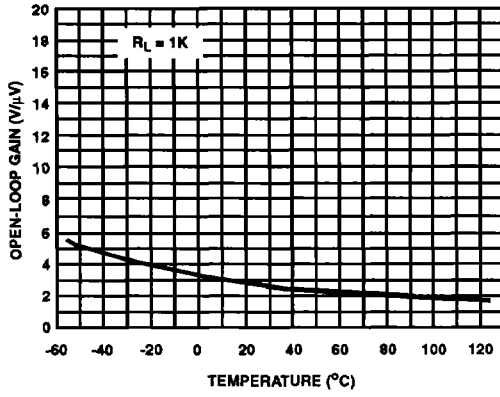

FIGURE 11. OPEN LOOP GAIN vs TEMPERATURE

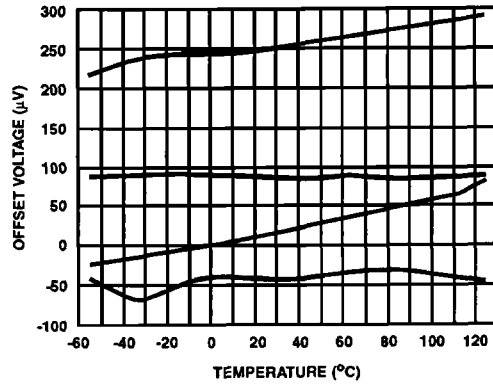

FIGURE 12. OFFSET VOLTAGE vs TEMPERATURE  
4 Representative Units

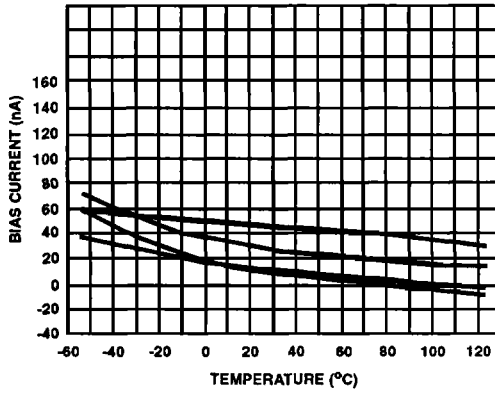

FIGURE 13. BIAS CURRENT vs TEMPERATURE  
4 Representative Units

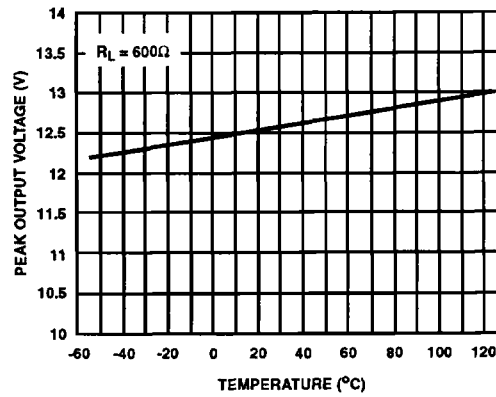

FIGURE 14. OUTPUT VOLTAGE SWING vs TEMPERATURE

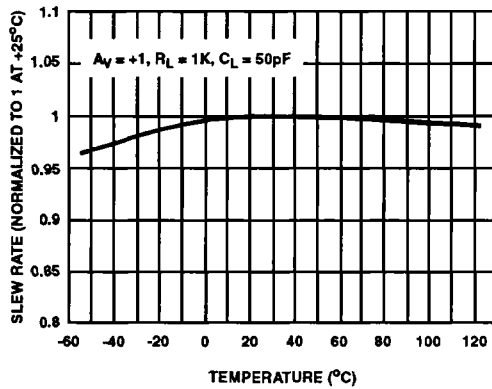

FIGURE 15. SLEW RATE vs TEMPERATURE

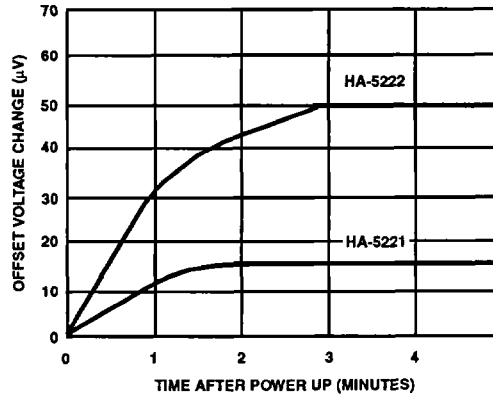

FIGURE 16. OFFSET VOLTAGE WARM-UP DRIFT  
Ceramic DIP Packages



Typical Performance Curves  $V_S = \pm 15V, T_A = +25^\circ C$  (Continued)

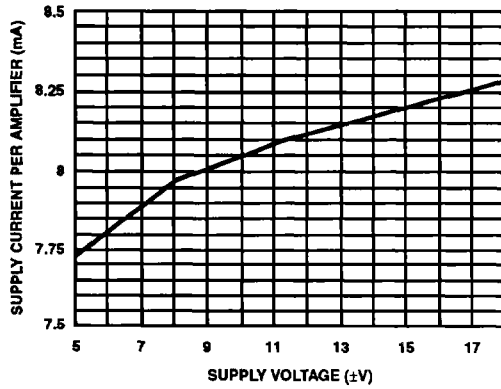

FIGURE 17. SUPPLY CURRENT vs SUPPLY VOLTAGE

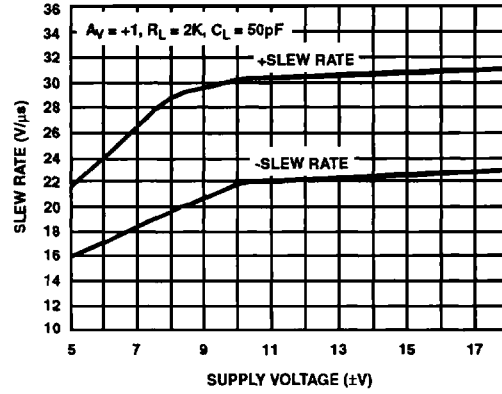

FIGURE 18. SLEW RATE vs SUPPLY VOLTAGE

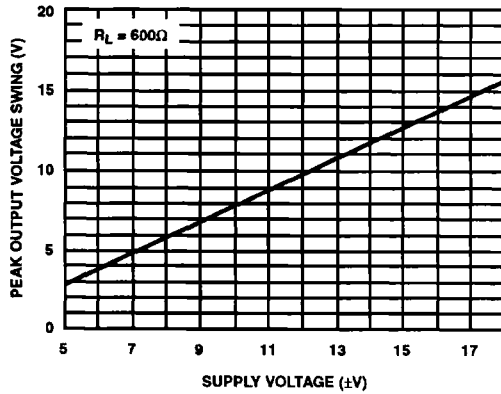

FIGURE 19. OUTPUT VOLTAGE SWING vs SUPPLY VOLTAGE

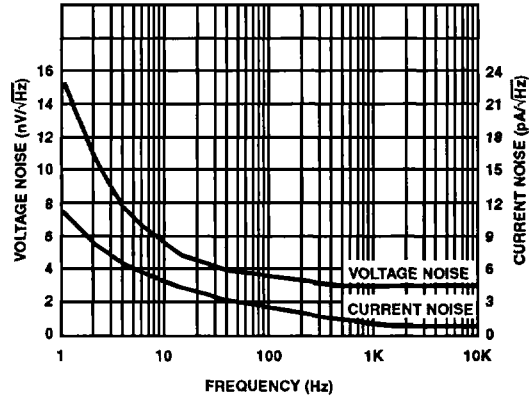

FIGURE 20. NOISE CHARACTERISTICS

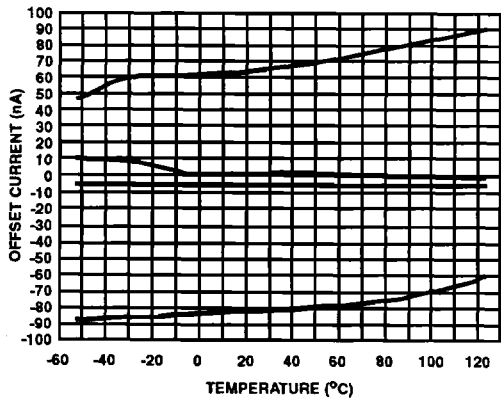

FIGURE 21. OFFSET CURRENT vs TEMPERATURE  
4 Representative Units

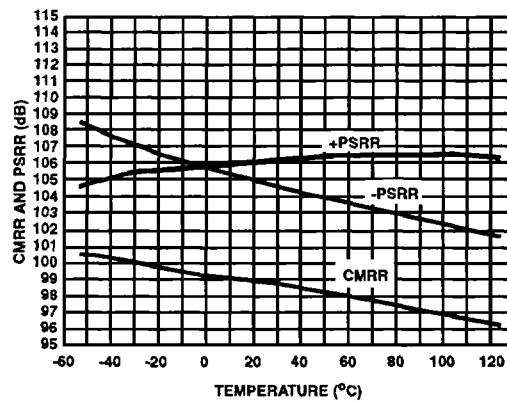

FIGURE 22. CMRR AND PSRR vs TEMPERATURE

Typical Performance Curves  $V_S = \pm 15V, T_A = +25^\circ C$  (Continued)

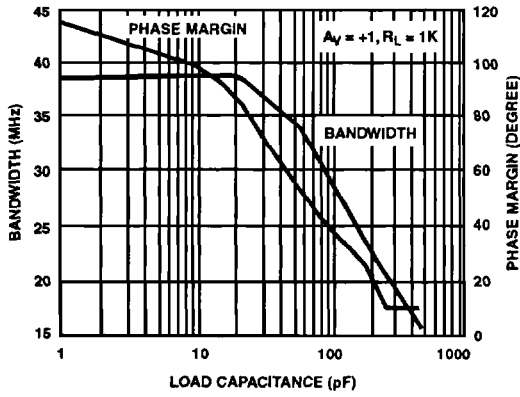

FIGURE 23. BANDWIDTH AND PHASE MARGIN vs LOAD CAPACITANCE

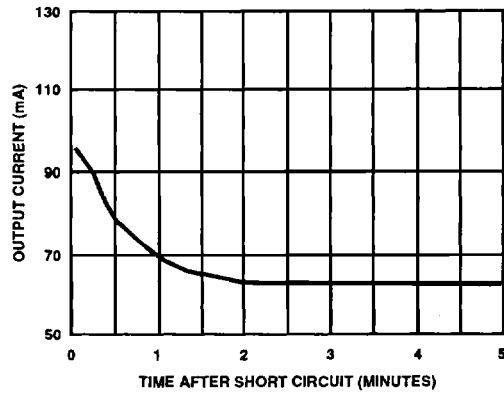

FIGURE 24. SHORT CIRCUIT OUTPUT CURRENT vs TIME

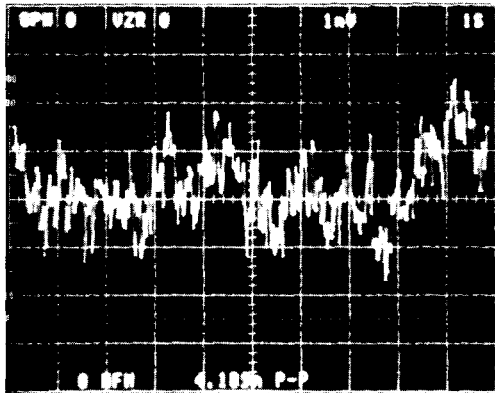

FIGURE 25. 0.1Hz TO 10Hz NOISE  
Vertical Scale: 1mV/div Horizontal Scale: 1 S/div  
 $A_V = +25,000 (E_N = 0.168\mu V_{p,p} RTI)$

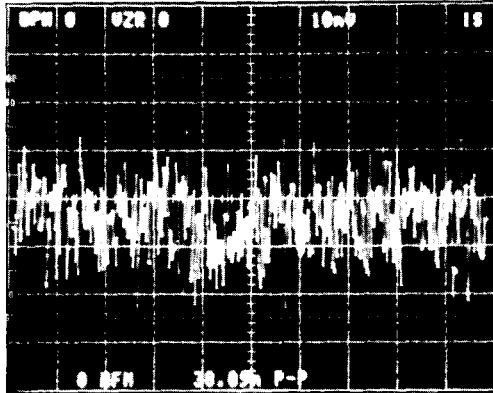

FIGURE 26. 0.1Hz TO 1MHz  
Vertical Scale: 10mV/div Horizontal Scale: 1 S/div  
 $A_V = +25,000 (E_N = 1.5\mu V_{p,p} RTI)$

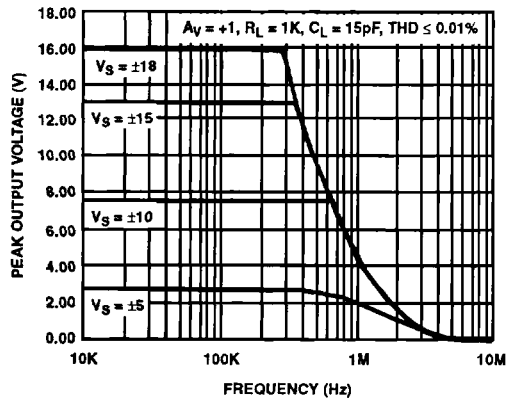

FIGURE 27. OUTPUT VOLTAGE SWING vs FREQUENCY

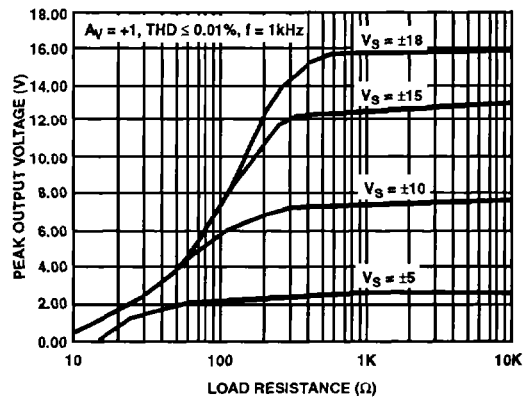

FIGURE 28. OUTPUT VOLTAGE SWING vs LOAD RESISTANCE

**Typical Performance Curves**  $V_S = \pm 15V, T_A = +25^\circ C$  (Continued)

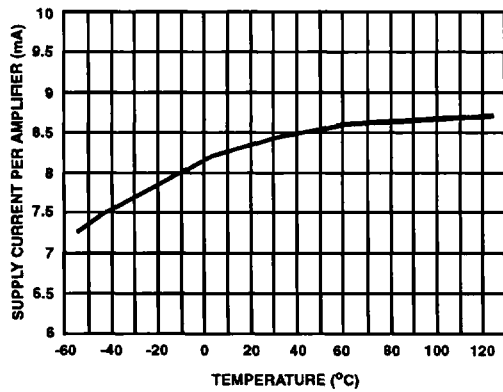

FIGURE 29. SUPPLY CURRENT/AMPLIFIER vs TEMPERATURE

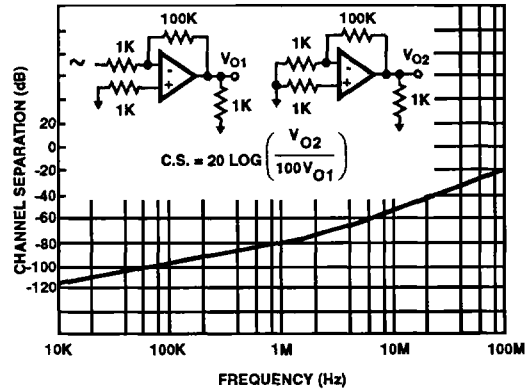

FIGURE 30. CHANNEL SEPARATION vs FREQUENCY (HA-5222 only)

**Applications Information**

**Operation at Various Supply Voltages**

The HA-5221/5222 operates over a wide range of supply voltages with little variation in performance. The supplies may be varied from  $\pm 5$  volts to  $\pm 15$  volts. See typical performance curves for variations in supply current, slew rate and output voltage swing.

**Offset Adjustment**

The following diagram shows the offset voltage adjustment configuration for the HA-5221. By moving the potentiometer wiper towards pin 8 (+BAL), the op amps output voltage will increase; towards pin 1 (-BAL) decreases the output voltage. A 20k $\Omega$  trim pot will allow an offset voltage adjustment of about 10mV.

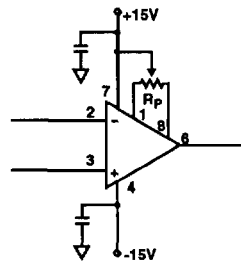

**Capacitive Loading Considerations**

When driving capacitive loads >80pF, a small resistor, 50 to 100 $\Omega$ , should be connected in series with the output and inside the feedback loop.

**Saturation Recovery**

When an op amp is over driven, output devices can saturate and sometimes take a long time to recover. By clamping the input, output saturation can be avoided. If output saturation can not be avoided, the maximum recovery time when over-driven into the positive rail is 10.6 $\mu s$ . When driven into the negative rail the maximum recovery time is 3.8 $\mu s$ .

**Input Protection**

The HA-5221/5222 has built in back-to-back protection diodes which limit the maximum allowable differential input voltage to approximately 5 volts. If the HA-5221/5222 will be used in circuits where the maximum differential voltage may be exceeded, then current limiting resistors must be used. The input current should be limited to a maximum of 10mA.

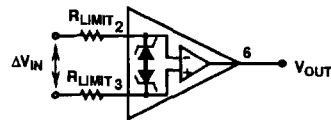

**PC Board Layout Guidelines**

When designing with the HA-5221 or the HA-5222, good high frequency (RF) techniques should be used when building a P.C. board. Use of ground plane is recommended. Power supply decoupling is very important. A 0.01 $\mu F$  to 0.1 $\mu F$  high quality ceramic capacitor at each power supply pin with a 2.2 $\mu F$  to 10 $\mu F$  tantalum close by will provide excellent decoupling. Chip capacitors produce the best results due to ease of placement next to the op amp and basically no lead inductance. If leaded capacitors are used, the leads should be kept as short as possible to minimize lead inductance.