

Tous droits strictement réservés. Reproduction ou communication à des tiers interdite sous quelque forme que ce soit sans autorisation écrite du propriétaire. Propriété de c FCI. Droits de reproduction FCI.

All rights strictly reserved. Reproduction or issue to third parties in any form whatever is not permitted without written authority from the proprietor. Property of FCI. Copyright FCI.

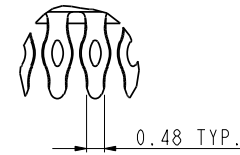

DETAIL T
SCALE 5.000

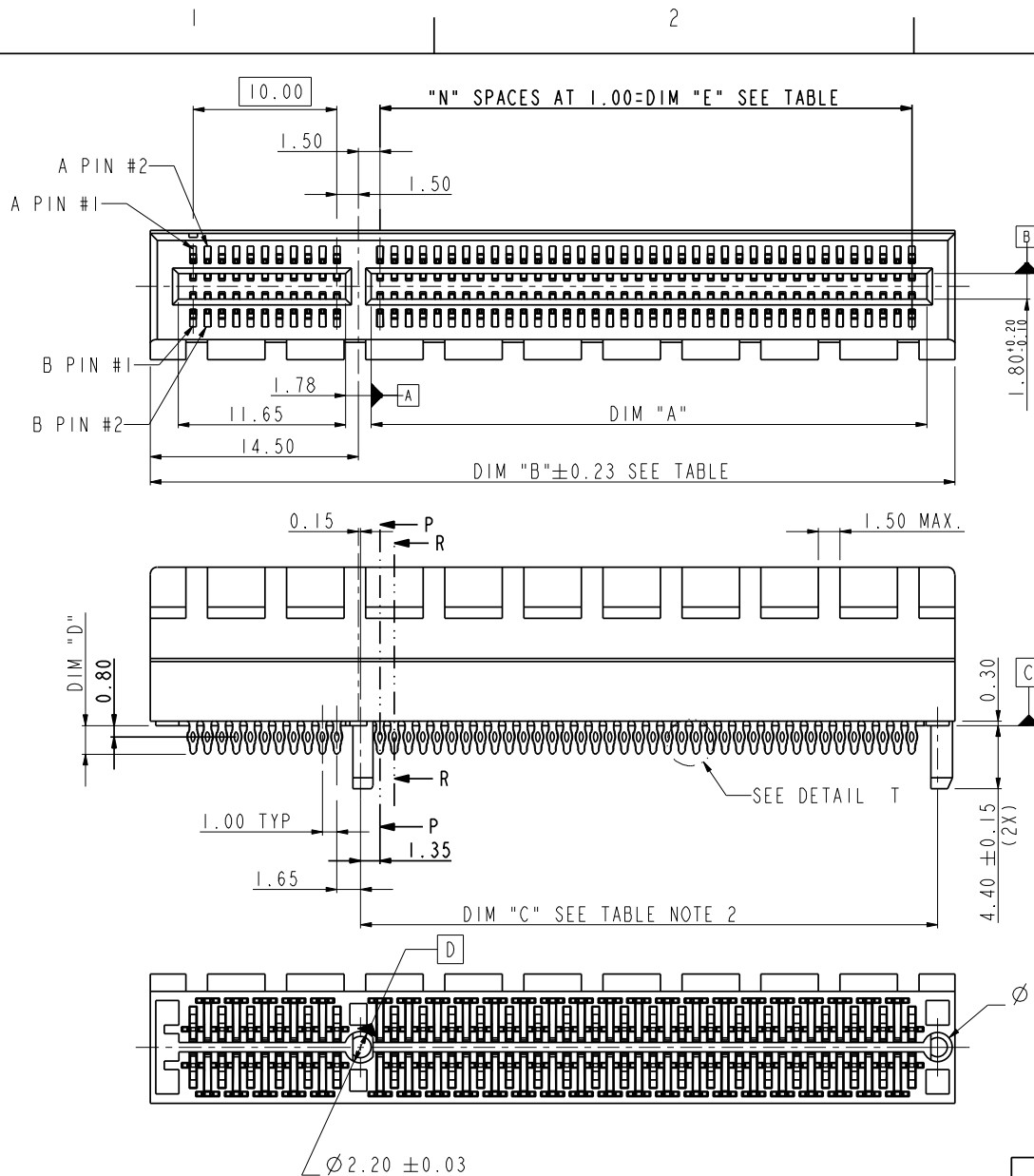
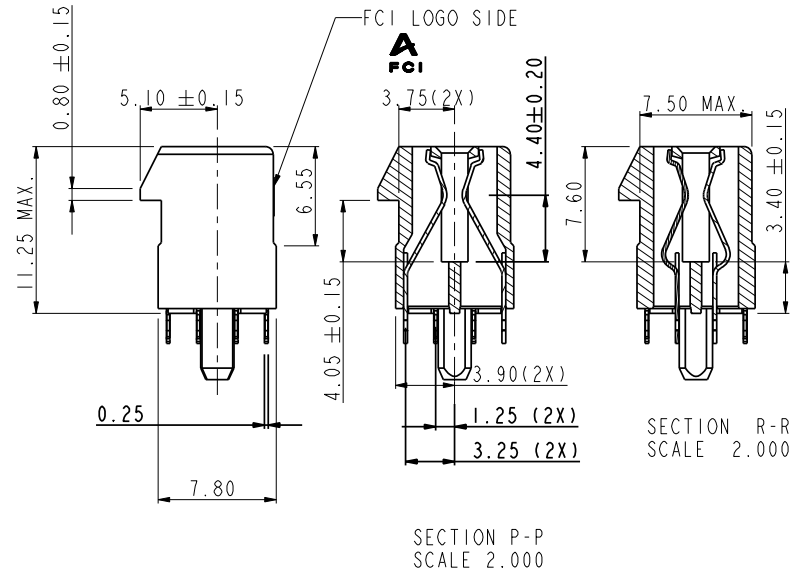

SECTION P-P
SCALE 2.000

SECTION R-R
SCALE 2.000

tolerance unless otherwise specified	
linear	.X ± .3
	.XX ± .2
	.XXX ± .1
angles	0° ± 2°

rev	ecn no	dr	date
A	T06-0001	M W	01/05/06
B	DG06-0161	P M	04/11/06
C	DG06-0276	P M	07/05/06

www.fciconnect.com		<input checked="" type="checkbox"/> tolerance	projection	<input checked="" type="checkbox"/> MM
Dr	MAGGIE WU	09/26/05	Product family	
Eng	R Y LIU	09/26/05	Spec ref	
Chr	PAUL WANG	09/26/05	Material	
Appr	JOSEPH HSIA	09/26/05	ECN DG06-0276	
title PCI Express STAND-OFF 0.3 mm PRESS-FIT ASS'Y			dwg no 10060018	Rev. C
catalog no PDM: Rev:C STATUS:Released CUSTOMER DRAWING sheet 1 of 6 Printed: Mar 15, 2011				

Tous droits strictement réservés. Reproduction ou communication à des tiers interdite sous quelque forme que ce soit sans autorisation écrite du propriétaire. Propriété de c FCI. Droits de reproduction FCI.

All rights strictly reserved. Reproduction or issue to third parties in any form whatever is not permitted without written authority from the proprietor. Property of FCI. Copyright FCI.

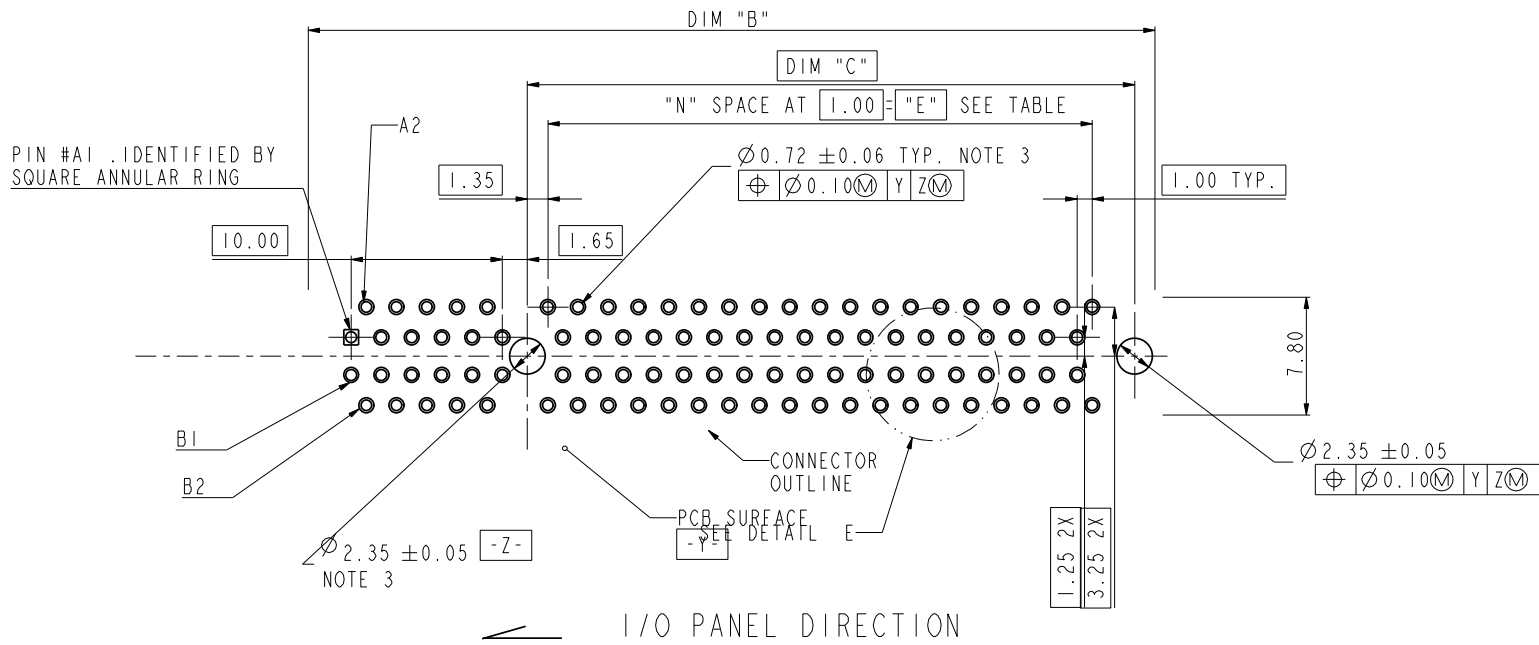

RECOMMENDED FOOTPRINT

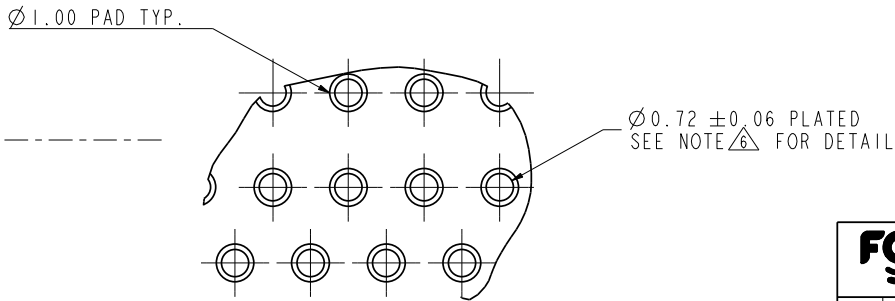

tolerance unless otherwise specified	
linear	.X ± .3 .XX ± .2 .XXX ± .1
angles	0° ± 2°

www.fciconnect.com		<input checked="" type="checkbox"/> tolerance	projection	MM
Dr	MAGGIE WU	09/26/05	Product family	
Eng	R Y LIU	09/26/05	Spec ref	
Chr	PAUL WANG	09/26/05	Material	
Appr	JOSEPH HSIA	09/26/05	ECN	DG06-0276

title	PCI Express STAND-OFF 0.3 mm PRESS-FIT ASS'Y	dwg no	10060018	Rev.	C
catalog no	PDM: Rev:C	CUSTOMER DRAWING		sheet 2 of 6	

Tous droits strictement réservés. Reproduction ou communication à des tiers interdite sous quelque forme que ce soit sans autorisation écrite du propriétaire. Propriété de c FCI. Droits de reproduction FCI.

All rights strictly reserved. Reproduction or issue to third parties in any form whatever is not permitted without written authority from the proprietor. Property of FCI. Copyright FCI.

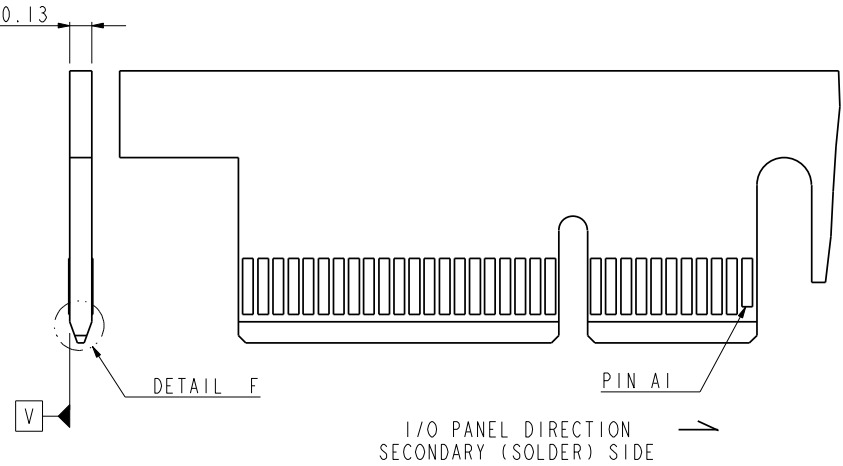
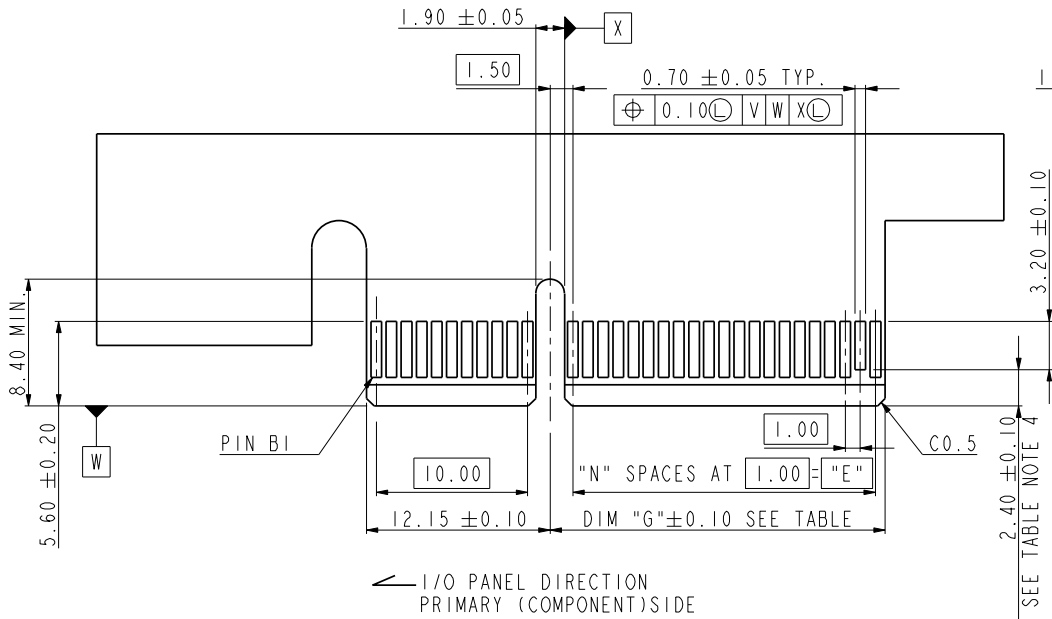

← I/O PANEL DIRECTION
PRIMARY (COMPONENT) SIDE

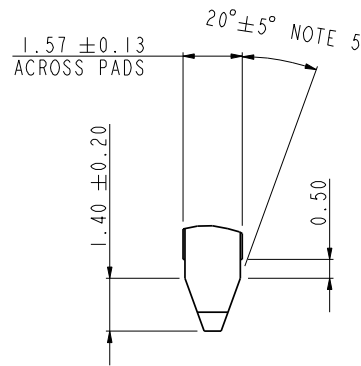

DETAIL F
SCALE 5.000

# POS REF.	N	DIM "G"	"F"
98	37	39.15	B48
164	70	72.15	B81

tolerance unless otherwise specified	
linear	.X ± .3 .XX ± .2 .XXX ± .1
angles	0° ± 2°

FCI www.fciconnect.com		✓	tolerance	projection	MM
Dr	MAGGIE WU	09/26/05	Product family	size	A4
Eng	R Y LIU	09/26/05	Spec ref	Scale	1.000
Chr	PAUL WANG	09/26/05	Material	ECN	DG06-0276
Appr	JOSEPH HSIA	09/26/05			

title	PCI Express STAND-OFF 0.3 mm PRESS-FIT ASS'Y	dwg no	10060018	Rev.	C
catalog no	PDM: Rev:C	STATUS: Released	CUSTOMER DRAWING	sheet 3 of 6	Printed: Mar 15, 2011

Tous droits strictement réservés. Reproduction ou communication à des tiers interdite sous quelque forme que ce soit sans autorisation écrite du propriétaire. Propriété de c FCI. Droits de reproduction FCI.

All rights strictly reserved. Reproduction or issue to third parties in any form whatever is not permitted without written authority from the proprietor. Property of FCI. Copyright FCI.



RECOMMENDED FOOTPRINT LAYOUT

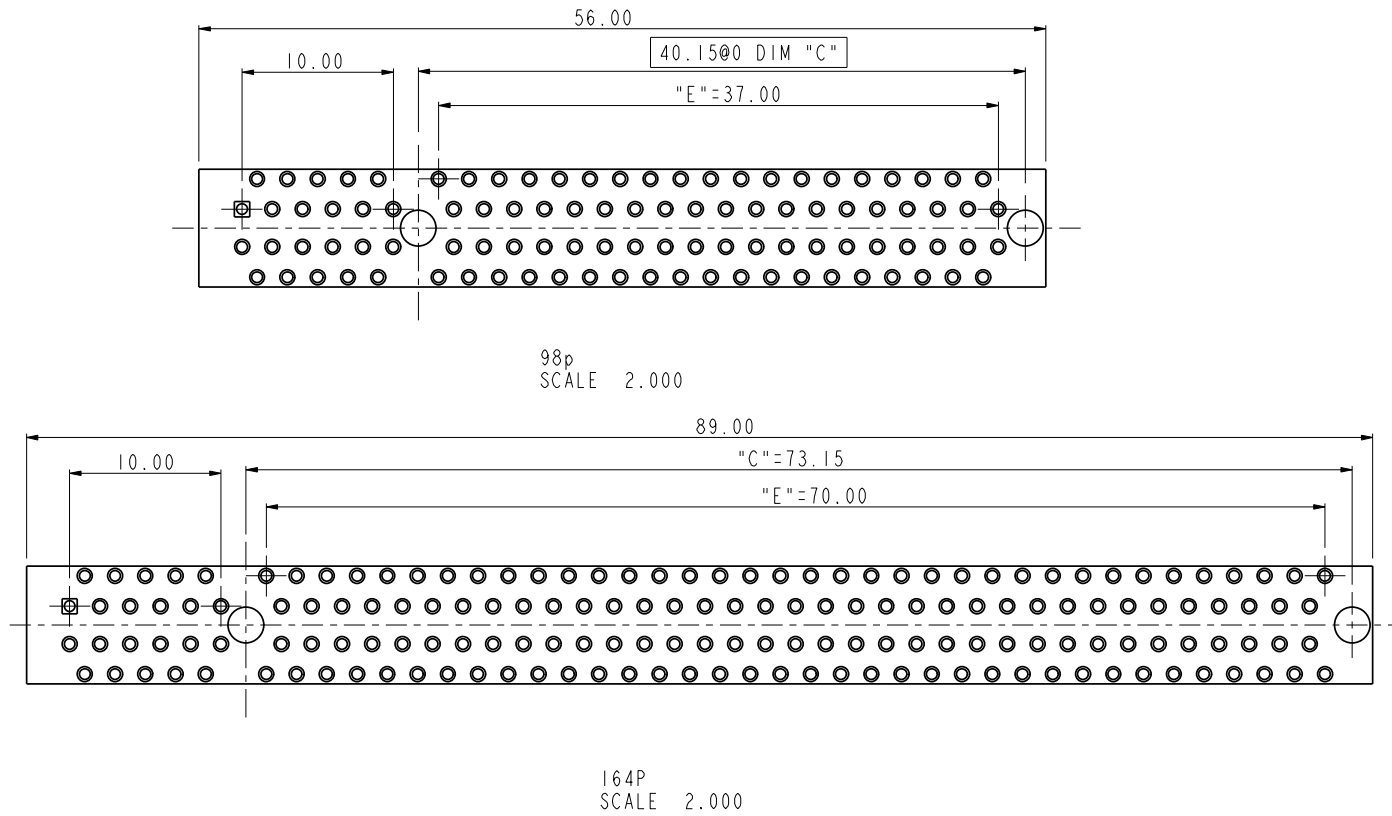

		www.fciconnect.com		✓	tolerance	projection	MM
Dr	MAGGIE WU	09/26/05	Product family	3G10		size	Scale
Eng	R Y LIU	09/26/05	Spec ref			A4	1.000
Chr	PAUL WANG	09/26/05	Material			ECN	DG06-0276
Appr	JOSEPH HSIA	09/26/05					
title			PCI Express STAND-OFF 0.3 mm PRESS-FIT ASS'Y			dwg no	
						10060018	
						Rev.	
						C	
catalog no			PDM: Rev:C			STATUS: Released	
			CUSTOMER			sheet 4 of 6	
						Printed: Mar 15, 2011	

Tous droits strictement réservés. Reproduction ou communication a des tiers interdite sous quelque forme que ce soit sans autorisation écrite du propriétaire. Propriété de c FCI. Droits de reproduction FCI.

All rights strictly reserved. Reproduction or issue to third parties in any form whatever is not permitted without written authority from the proprietor. Property of FCI. Copyright FCI.

NOTES:

1. MATERIAL:
HOUSING: HIGH TEMPERATURE NYLON, GLASS FILLED UL94V-0 RATED. SUITABLE FOR REFLOW SOLDERING.
TERMINAL: COPPER ALLOY
PLATING: 50u" NICKEL UNDERPLATE ALL OVER
CONTACT AREA PLATING - SEE PRODUCT NUMBER CODE
SOLDER TAIL: TIN - 100u" MIN. OVER 50u" NICKEL OR TIN/LEAD 100u" MIN. SEE PRODUCT NUMBER CODE
2. PRODUCT SPECIFICATION: GS-12-319
3. THE HORIZONTAL AXIS FOR THE HOLE PATTERN IS ESTABLISHED BY A LINE THROUGH THE CENTER OF THE TWO Ø2.35 HOLES.
THE VERTICAL AXIS IS 90° TO THE HORIZONTAL AXIS, THROUGH THE CENTER OF DATUM Z.
4. NO TIE BAR PERMITTED FROM CARD EDGE TO LEADING EDGE OF PAD FOR PINS A1 AND PIN NUMBERS "F".
5. CHAMFER EDGES MUST BE FREE OF CUTTING BURRS.
6. ALL PTH SHOULD BE 0.76-0.83 mm DIA DRILLED AND 0.025-0.05 mm. ELECTRO-DEPOSITED COPPER THK ON THROUGH HOLE WALL.
7. RoHS COMPATIBLE PRODUCT SPECIFICATIONS
a-PLATING:
- "LF" MEANS THE PRODUCT IS LEAD-FREE, 2um MINIMUM MATTE TIN OVER 1.27um MINIMUM NICKEL UNDERPLATE.
b-MANUFACTURING PROCESS COMPATIBILITY
- THE HOUSING WILL WITHSTAND EXPOSURE TO 260°C±5°C SOLDER BATH TEMPERATURE FOR 5 SECONDS IN A REFLOW SOLDER APPLICATION WITH A 1.6mm MIN THICK CIRCUIT BOARD.

CONNECTOR	# POS REF.	N	DIM "A"	DIM "B"	DIM "C"	DIM "E"
1 PORT	36	6	7.65	25.00	9.15	6.00
4 PORT	64	20	21.65	39.00	23.15	20.00
8 PORT	98	37	38.65	56.00	40.15	37.00
16 PORT	164	70	71.65	89.00	73.15	70.00

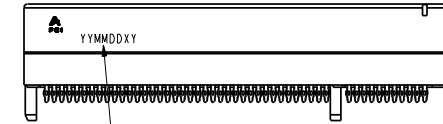

Date code:
 "YY" means year number
 "MM" means month number
 "DD" means day number
 "X" means manufacture location
 "D" means made in Dongguan site
 "Y" means shift number
 If date code is 060626D1, it means this part is made by shift 1 in 2006/06/26 and manufactured in Dongguan site
 Date code should be laser mark

PRODUCT NUMBER CODE

10060018 - X X X X X X X X

HOUSING COLOR OPTIONS
1-BLACK

PEGS OPTIONS
0-PLASTIC PEGS

TERMINAL PLATING OPTIONS
 0-50u" Ni UNDERPLATE
 30u" Au CONTACT AREA
 100u" TIN TAIL AREA -----COMPATIBLE RoHS
 1-50u" Ni UNDERPLATE
 15u" Au CONTACT AREA
 100u" TIN TAIL AREA -----COMPATIBLE RoHS
 2-50u" Ni UNDERPLATE
 GOLD FLASH CONTACT AREA
 100u" TIN TAIL AREA -----COMPATIBLE RoHS
 3-50u" Ni UNDERPLATE
 30u" Au CONTACT AREA
 100u" TIN/LEAD TAIL AREA -----RoHS COMPLIANT EXCEPT Pb
 4-50u" Ni UNDERPLATE
 15u" Au CONTACT AREA
 100u" TIN/LEAD TAIL AREA -----RoHS COMPLIANT EXCEPT Pb
 5-50u" Ni UNDERPLATE
 GOLD FLASH CONTACT AREA
 100u" TIN/LEAD TAIL AREA -----RoHS COMPLIANT EXCEPT Pb

LEAD FREE OPTION
"LF" FOR TERMINAL PLATING OPTION 0,1,2
LEAVE BLANK FOR TERMINAL PLATING 3,4,5

PACKAGING OPTIONS
T-TRAY PACKAGING

POS OPTIONS
0-36
1-64
2-98
3-164

	DIM "D"	SUGGESTED PCB THICKNESS
0	2.00±0.20	2.36
1	3.25±0.20	4.19

TAIL LENGTH OPTIONS

tolerance unless otherwise specified	
linear	.X ± .3 .XX ± .2 .XXX ± .1
angles	0° ± 2°

www.fciconnect.com			<input checked="" type="checkbox"/> tolerance	<input type="checkbox"/> projection	<input checked="" type="checkbox"/> MM
Dr	MAGGIE WU	09/26/05	Product family	size	A4
Eng	R Y LIU	09/26/05	Spec ref	Scale	1.000
Chr	PAUL WANG	09/26/05	Material	ECN	DG06-0276
Appr	JOSEPH HSIA	09/26/05			
title PCI Express STAND-OFF 0.3 mm PRESS-FIT ASS'Y			dwg no 10060018	Rev. C	
catalog no			CUSTOMER DRAWING sheet 5 of 6		

PDM: Rev:C

STATUS: Released

Printed: Mar 15, 2011

Tous droits strictement reserves. Reproduction ou communication a des tiers interdite sous quelque forme que ce soit sans autorisation ecrite du proprietaire. Propriete de c FCI. Droits de reproduction FCI.

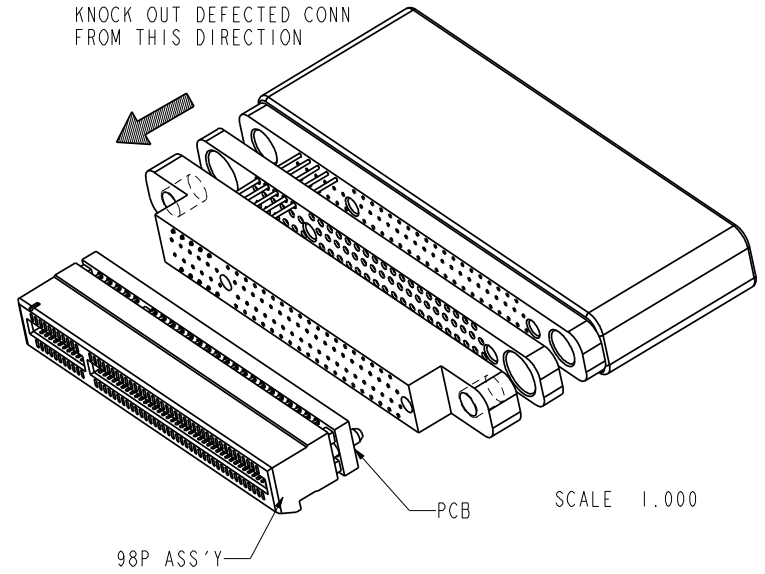
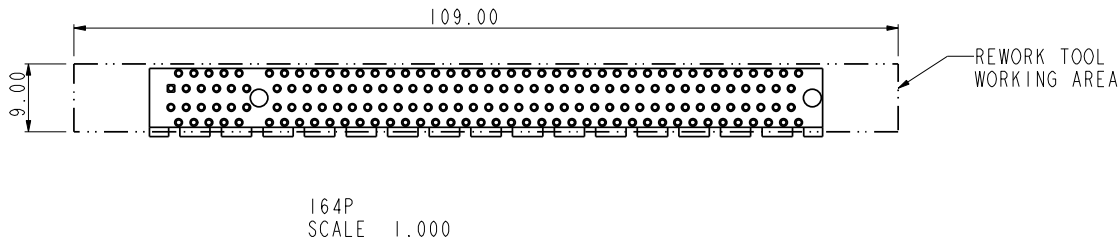
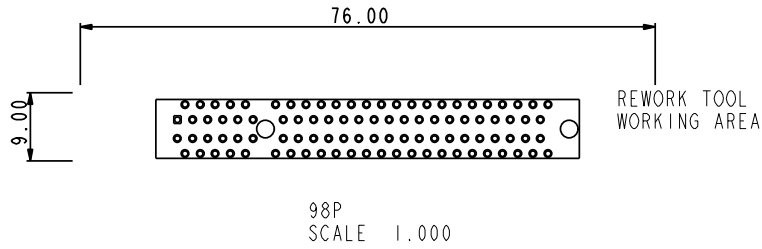

tolerance unless otherwise specified	
linear	.X ± .3
	.XX ± .2
	.XXX ± .1
angles	0° ± 2°

FCI www.fciconnect.com		✓	tolerance	projection	MM
Dr	MAGGIE WU	09/26/05	Product family	size	Scale
Eng	R Y LIU	09/26/05	Spec ref	A4	1.000
Chr	PAUL WANG	09/26/05	Material	ECN	DG06-0276
Appr	JOSEPH HSIA	09/26/05			

title		PCI Express STAND-OFF 0.3 mm PRESS-FIT ASS'Y	dwg no	10060018	Rev.	C
catalog no		PDM: Rev:C	CUSTOMER DRAWING		sheet 6 of 6	

All rights strictly reserved. Reproduction or issue to third parties in any form whatever is not permitted without written authority from the proprietor. Property of FCI. Copyright FCI.

