

- 1. POST TO WITHSTAND 13 NEWTONS (3LBS.) MIN. AXIAL FORCE IN BOTH DIRECTIONS SHOWN WITHOUT DISLODGING.
- 2. TOLERANCES APPLY TO SOLDER SIDE OF BOARD.
- 3. MEASURED AT SURFACE \square -A-
- 4. PLASTIC FLASH PERMITTED IN THIS AREA.
- 5. PARTS COMPLY WITH AMP SOLDERABILITY SPEC. NO. 109-11-2.
- 6. ONE HOLE MAY BE UNDERSIZED (.035/.032 DIA.) FOR ASSEMBLY RETENTION DURING WAVE SOLDERING.
- 7. MATERIAL: HEADER-THERMOPLASTIC POLYESTER 94V-0(NATURAL) POST-COPPER ALLOY (TIN PLATED)
- 8. COORDINATE DIMENSION APPLIES FROM CENTER OF ACTUAL FEATURE.
- 9. PLASTIC BURRS CAUSED BY CUT-OFF TOOLING ARE PERMITTED WITHIN THE MAXIMUM TOLERANCE ENVELOPE.
- 10. POST TO BE MEASURED WHEN STRIP IS HELD FLAT.
- 11. POST MUST WITHSTAND TWO 90° BENDS AGAINST EXTRUSION WITHOUT BREAKING.
- 12. DIMENSION SHOULD BE .130 MIN WHEN MATING WITH A MTA 100 CONNECTOR ASSEMBLY OR WHEN MATING WITH A CST 100 CONNECTOR.
- 13. PIN BURR OF .005 MAX VERTICAL AND .003 MAX HORIZONTAL PERMITTED AT POST TIPS ON BOTH ENDS.
- 14. COLOR STRIPE YELLOW IN APPROXIMATE LOCATION SHOWN FOR 644831-1. COLOR STRIPE RED IN APPROXIMATE LOCATION SHOWN FOR 644831-2.

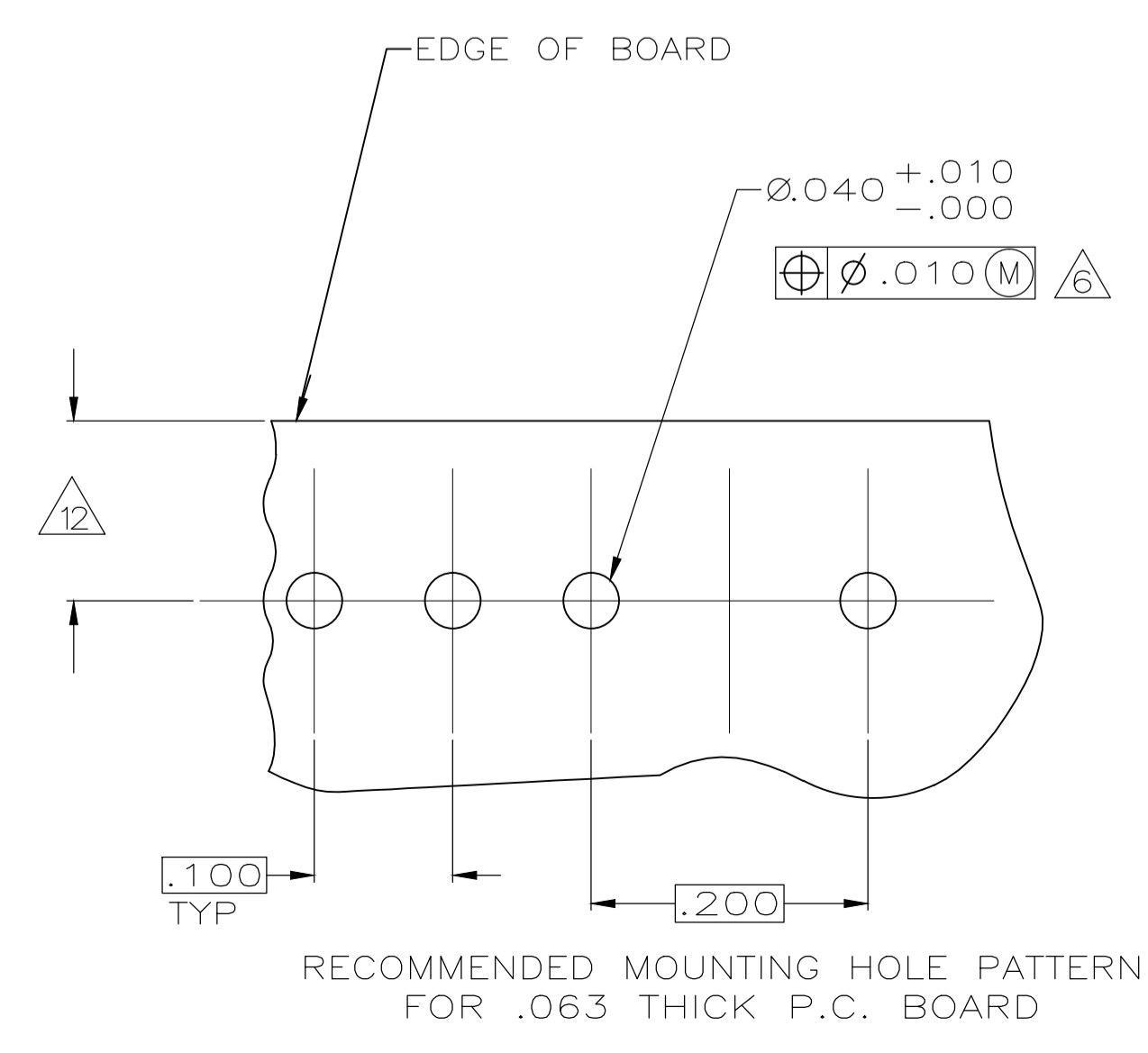

IN	MM	IN	MM
.050	1.27	-	-
.040	1.02	.535	13.59
.035	0.89	.500	12.70
.032	0.81	.310	7.87
.030	0.76	.295	7.49
.025	0.64	.225	5.72
.020	0.51	.200	5.08
.015	0.38	.150	3.81
.010	0.25	.140	3.56
.008	0.20	.130	3.30
.005	0.13	.125	3.18
.003	0.08	.100	2.54
.001	0.03	.063	1.60
IN	MM	IN	MM

644831-1 SHOWN

4	644831-2
2	644831-1
POST NO. OMITTED	PART NO



THIS DRAWING IS A CONTROLLED DOCUMENT.

DIMENSIONS: INCHES	TOLERANCES UNLESS OTHERWISE SPECIFIED:	DIN B. LEWIS 1-11-95	NAME
0. PLC ± -	1. PLC ± -	CHK R. SWING 1-11-95	MTA-100 HEADER ASSEMBLY, FRICTION LOCK, NOTCHED, .025 SQUARE STRAIGHT POST, TIN PLATED.
2. PLC ± -	3. PLC ± .005	APP'D B. GENTRY 1-29-95	APPLICATION SPEC
4. PLC ANGLES ± ° 30'			WEIGHT
MATERIAL	FINISH	SIZE	SCALE
		A1	8:1
		DRAWING NO. 00779	SHEET 1 OF 1
		REVISED PER ECO-14-011424	REV B1

