

# EasyLED™

Manual

*All Mikroelektronika's development systems feature a large number of peripheral modules expanding microcontroller's range of application and making the process of program testing easier. In addition to these modules, it is also possible to use numerous additional modules linked to the development system through the I/O port connectors. Some of these additional modules can operate as stand-alone devices without being connected to the microcontroller.*

Additional board

 **MikroElektronika**

SOFTWARE AND HARDWARE SOLUTIONS FOR EMBEDDED WORLD ...making it simple

---

## EasyLED

The EasyLED additional board is used to connect a development system port to LEDs.

### Key features:

- Parallel communication;
- 8 LEDs;
- 3.3V or 5V power supply voltage.

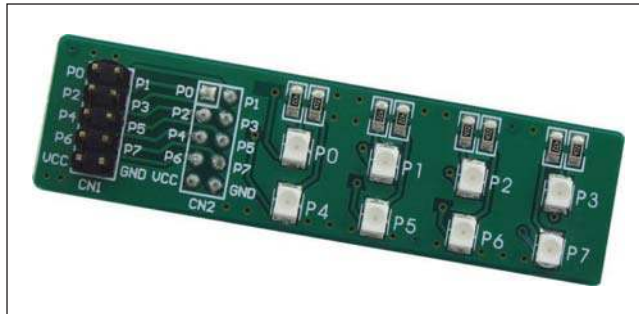

Figure 1: EasyLED additional board

### How to connect the board?

The EasyLED additional board can be easily connected to a development system via an IDC10 connector CN2. The CN1 connector is used to access the port pins the additional board is connected to.

### How to use the board?

The EasyLED board is used to show the logic level on the development system ports. When a pin is driven high (logic 1), the appropriate LED connected to that pin is turned on. Likewise, if a pin is driven low (logic 0), the appropriate LED will not illuminate.

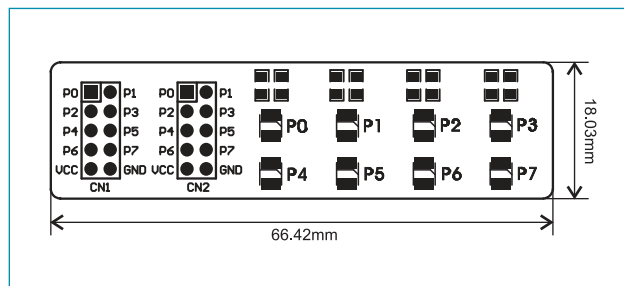
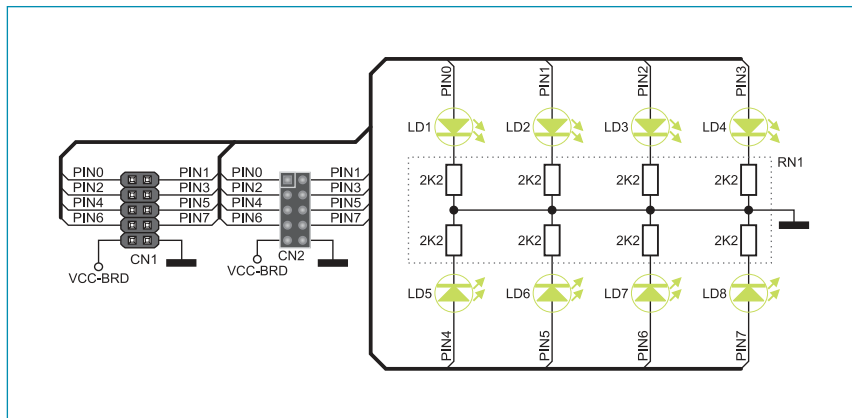

Figure 2: Dimensions of the EasyLED board

**Note:** When the EasyLED board features red LEDs, the value of the RN1 resistor is 4K7.



**Figure 3:** The EasyLED board connection schematic



**MikroElektronika**

SOFTWARE AND HARDWARE SOLUTIONS FOR EMBEDDED WORLD ... *making it simple*

If you want to learn more about our products, please visit our website at [www.mikroe.com](http://www.mikroe.com)

If you are experiencing some problems with any of our products or just need additional information, please place your ticket at [www.mikroe.com/en/support](http://www.mikroe.com/en/support)

If you have any questions, comments or business proposals, do not hesitate to contact us at [office@mikroe.com](mailto:office@mikroe.com)