

Connector-Specific Kit 679167-4

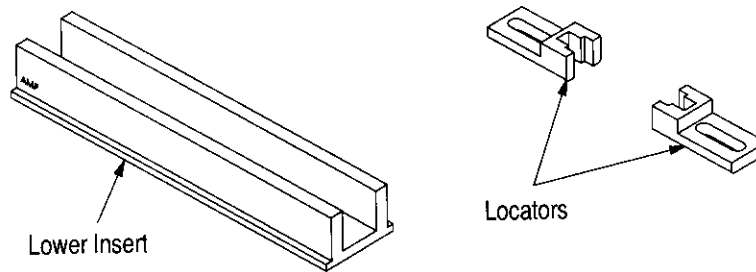

Typical Application Tooling

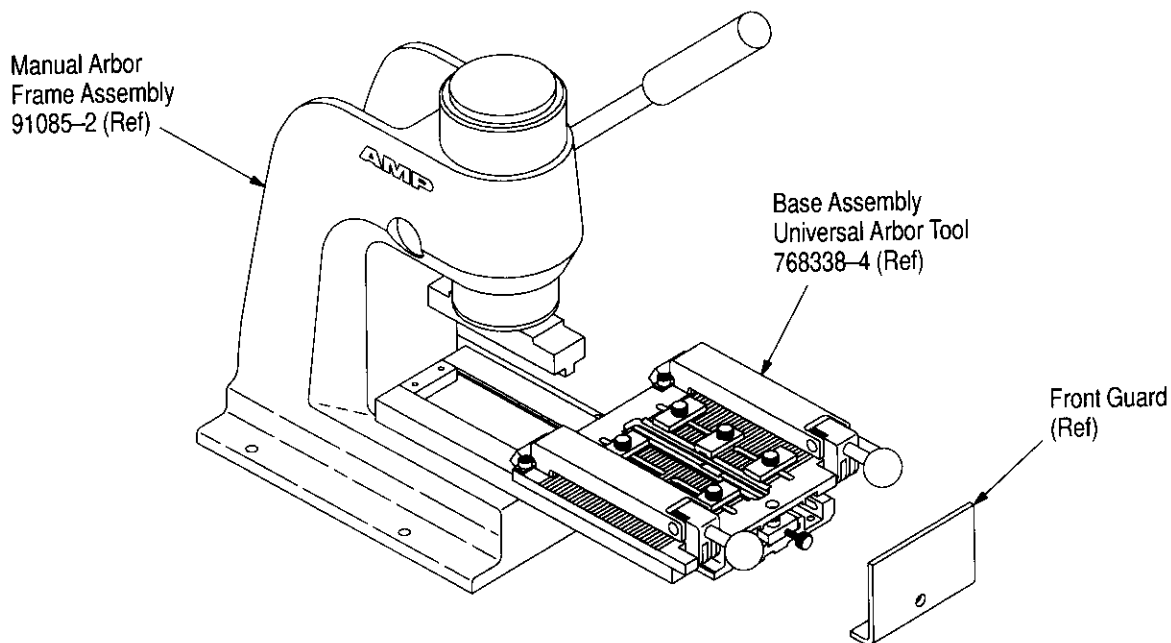

Figure 1

1. INTRODUCTION

This instruction sheet covers the installation and setup procedures for AMP* Connector-Specific Kit 679167-4. The connector-specific kit is used in conjunction with Base Assembly Universal Arbor Tool 768338-4 and AMP Manual Arbor Frame Assembly 91085-2 (see Figure 1), or AMP Pneumatic Auto-Cycle Unit 91112-3 to terminate AMPMODU System 50 Receptacle Connectors to 0.64 mm [.025 in.] centerline flat ribbon cable.

Refer to instruction sheets 408-7777 (supplied with Manual Arbor Frame Assembly) or 408-6732

(supplied with Pneumatic Auto-Cycle Unit) for tooling information. Installation and termination procedures for the Base Assembly Universal Arbor Tool are available in 408-4201.

NOTE

Dimensions on this sheet are in millimeters [followed by inches in brackets]. Figures are not drawn to scale.

2. DESCRIPTION (Figure 1)

The connector-specific kit features a lower insert and two locators. The lower insert and locators properly align the connector for termination.

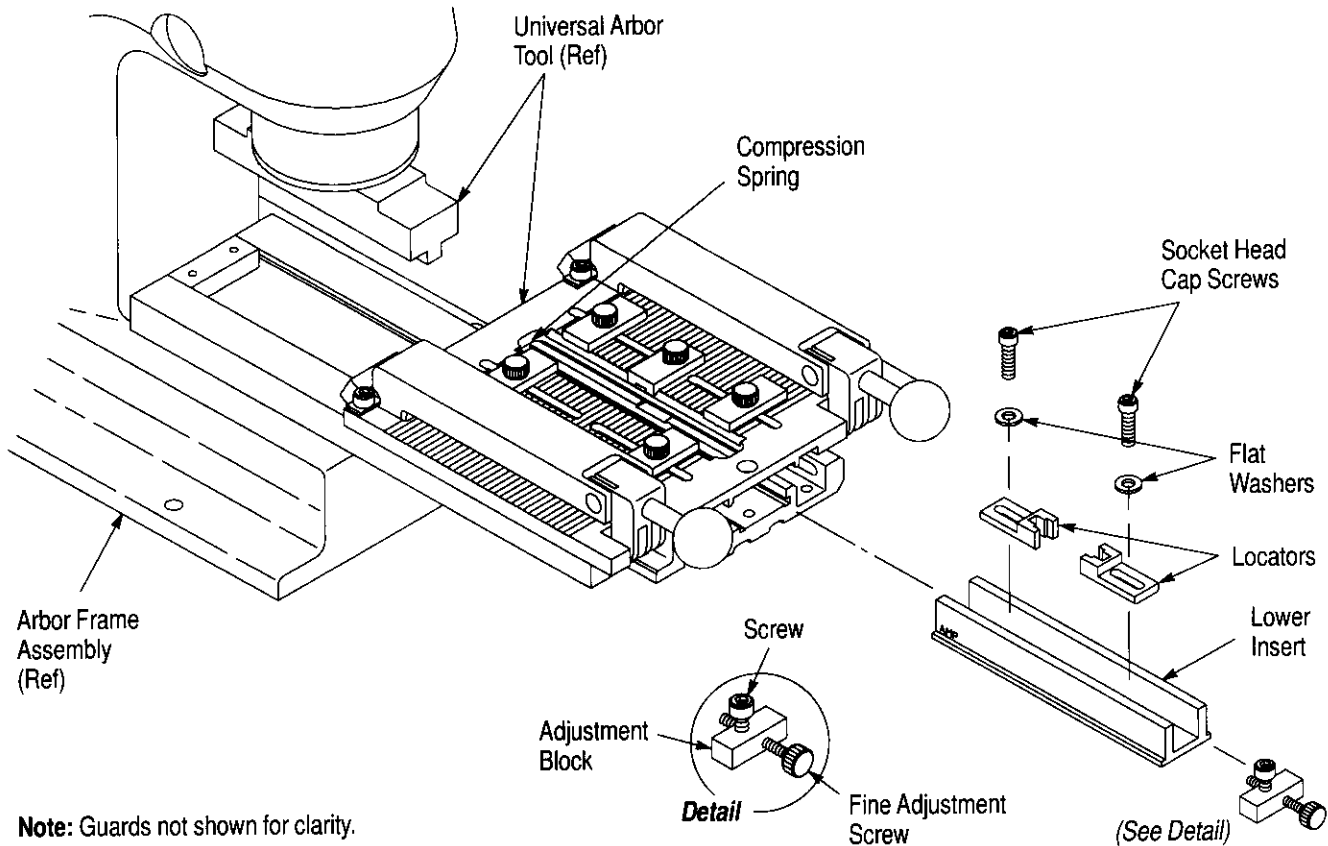

Figure 2

3. INSTALLATION AND SETUP OF CONNECTOR-SPECIFIC KIT

3.1. Installation

These procedures are typical for the Manual Arbor Frame Assembly and the Pneumatic Auto-Cycle Unit. Before installing the connector-specific kit, install the Base Assembly Universal Arbor Tool onto the frame assembly, as described in 408-4201.

DANGER When using the Pneumatic Auto-Cycle Unit, DISCONNECT air from main air valve.

1. Secure the locators onto the lower insert using the flat washers and socket head cap screws. Tighten the screws just enough to hold the locators in place. Refer to Figure 2.
2. Place the connector between the locators and slide the locators against the connector body—the latches should fit in the cutout in the locators. Then secure the locators by fully tightening the socket head cap screws. See Figure 3.
3. When the locators are secure, remove the connector from the lower insert.
4. Remove the screw that secures the adjustment block to the universal arbor tool, then remove the

adjustment block. Slide the lower insert onto the base assembly until it is against the compression spring. See Figure 2.

5. Re-assemble the adjustment block. Make sure to orient the block so that the fine adjustment screw is closest to the right side and bottom side of the block. See detail in Figure 2.

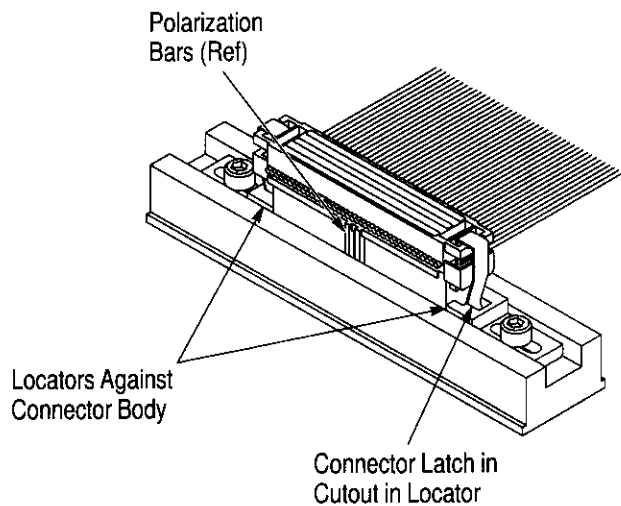

Figure 3

CAUTION

To avoid improper terminations, the adjustment block must be re-assembled properly.

- Loosen the fine adjustment screw so that it is not touching the lower insert.

3.2. Setup

- Remove the cover from the connector and place the connector into the lower insert as described in Paragraph 3.1. Take note of the polarization bars on the connector (refer to Figure 3)—make sure that each connector is oriented the same for production as the setup connector.

NOTE

After setup, the setup connector is unusable for final termination; however, it can be re-used for future setups.

- Position the cable into the universal arbor tool and follow the termination procedures according to 408-4201.

NOTE

For end of cable terminations, the cable can be positioned on either the left or right side of the fluted plate to accommodate the connector.

3.3. Connector Inspection

- Perform a test termination and inspect the connector to ensure that the cable conductors are aligned with the contacts. If available, use a tester to inspect the termination, or remove the connector cover and inspect the termination with a microscope to ensure that the cable conductors

are properly aligned with the contacts. Refer to applicable AMP application specification (114-series) for termination height dimensions.

- If the cable conductors are not aligned with the contacts, a re-alignment of the connector is necessary. Determine the direction the connector must be moved to align the cable conductors with the contacts. Loosen the two locking setscrews on the universal arbor tool (which secure the lower insert) and re-align the lower insert.

NOTE

For additional information on connector and cable alignment, refer to the instructions packaged with the universal arbor tool (408-4201).

4. CONNECTOR-SPECIFIC KIT INSPECTION

The connector-specific kit has been inspected and should be verified with the information provided in Figure 4. AMP recommends that the kit be inspected immediately upon its arrival at your facility (and at regularly scheduled intervals) to ensure that the kit components have not been damaged during handling.

For additional information concerning connector-specific kits, or to purchase additional kits, contact your local AMP representative or:

CUSTOMER SERVICE (38-35)
AMP INCORPORATED
PO BOX 3608
HARRISBURG, PA 17105-3608

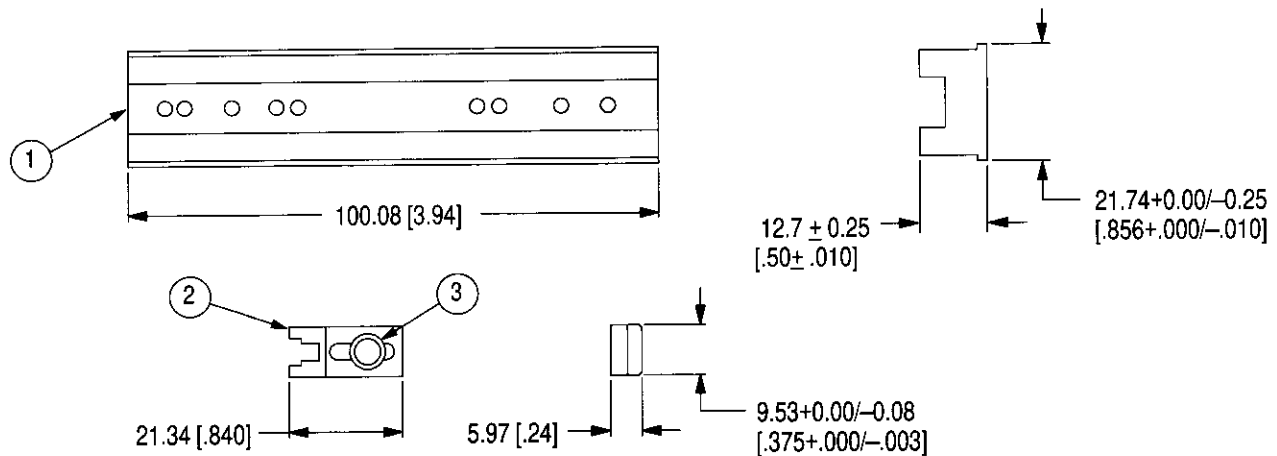

REPLACEABLE PARTS

ITEM	PART NUMBER	DESCRIPTION	QTY PER KIT
1	679074-1	LOWER INSERT	1
2	679075-1	LOCATOR	2
3	1-21000-4	SCREW, Socket Head Cap, 4-40 x .38 in. L	2

Figure 4