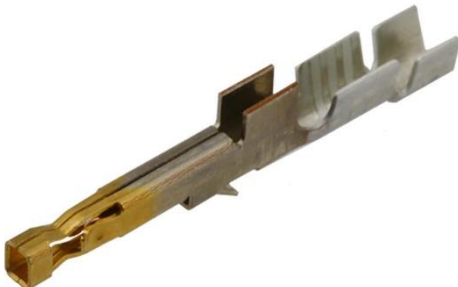
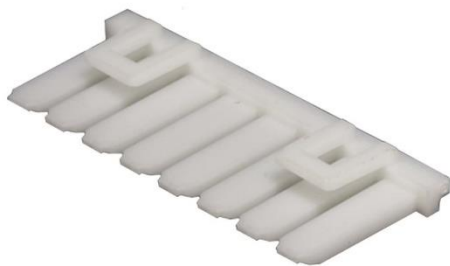
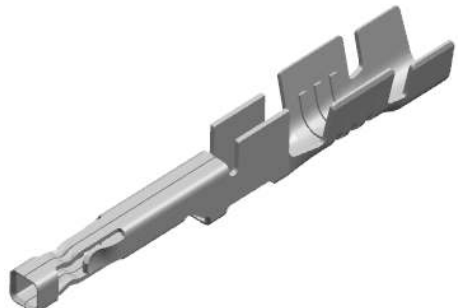
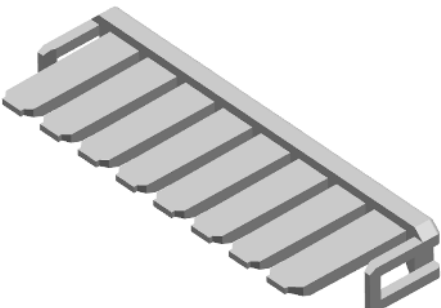


ULTRA-FIT

WIRE-TO-BOARD CONNECTOR SYSTEM

Receptacle Terminal	TPA
	
Series: 172253	Series: 172264 , 172268


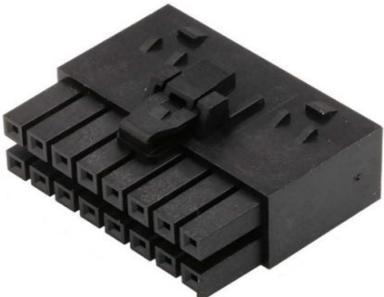
Tangless Receptacle Terminal	Tangless TPA
	
Series: 172253	Series: 172264

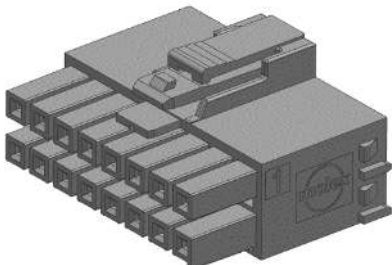
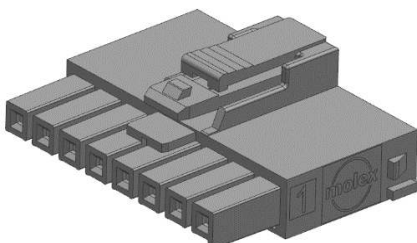
[MOLEX ULTRA-FIT WEB PAGE](#)

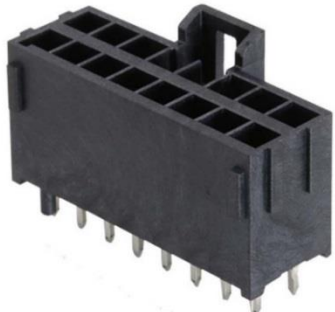



TABLE OF CONTENTS

REVISION: C	ECR/ECN INFORMATION: EC No: 668512 DATE: 06/29/2021	TITLE: PRODUCT SPECIFICATION FOR ULTRA-FIT CONNECTOR SYSTEM	SHEET No. 1 of 23
DOCUMENT NUMBER: PS-172323-0001	CREATED / REVISED BY: Dixon.Li	CHECKED BY: JONNY.ZHENG	APPROVED BY: ANSON.YIN

Receptacle Housing Single Row	Receptacle Housing Dual Row
	
Series: 172256	Series: 172258

Tangless Receptacle Housing Dual Row	Tangless Receptacle Housing Single Row
	
Series: 172258	Series: 172256

Vertical Header, Kinked Pins	
	
Series: 172298	Series: 172286

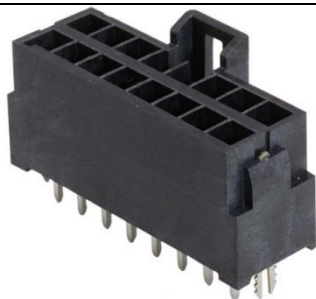
[MOLEX ULTRA-FIT WEB PAGE](#)



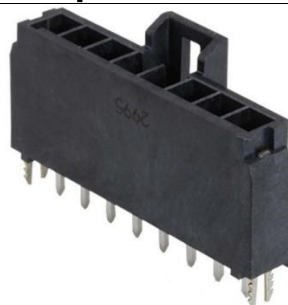
TABLE OF CONTENTS

REVISION: C	ECR/ECN INFORMATION: EC No: 668512 DATE: 06/29/2021	TITLE: PRODUCT SPECIFICATION FOR ULTRA-FIT CONNECTOR SYSTEM		SHEET No. 2 of 23
DOCUMENT NUMBER: PS-172323-0001		CREATED / REVISED BY: Dixon.Li	CHECKED BY: JONNY.ZHENG	APPROVED BY: ANSON.YIN

Vertical Header, Solder Clip

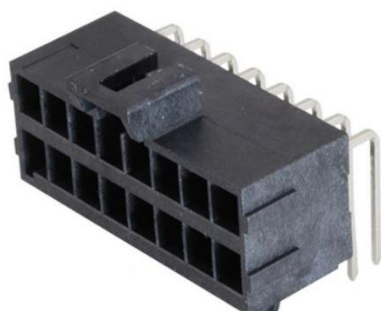


Series: [172299](#)



Series: [172287](#)

Right Angle Header

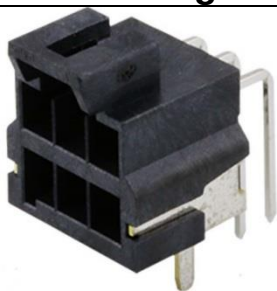


Series: [172316](#)

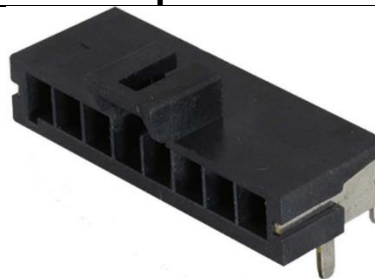


Series: [172310](#)

Right Angle Header, Solder Clip



Series: [172316](#)



Series: [172310](#)

[MOLEX ULTRA-FIT WEB PAGE](#)



[TABLE OF CONTENTS](#)

REVISION: C	ECR/ECN INFORMATION: EC No: 668512 DATE: 06/29/2021	TITLE: PRODUCT SPECIFICATION FOR ULTRA-FIT CONNECTOR SYSTEM	SHEET No. 3 of 23
DOCUMENT NUMBER: PS-172323-0001	CREATED / REVISED BY: Dixon.Li	CHECKED BY: JONNY.ZHENG	APPROVED BY: ANSON.YIN

1.0	SCOPE	<u>5</u>
2.0	PRODUCT DESCRIPTION	<u>5</u>
2.1	Product Name and Series Numbers	<u>5</u>
2.2	Dimensions, Materials, Plating and Markings	<u>5</u>
2.3	Safety Agency Approvals	<u>5</u>
3.0	APPLICABLE DOCUMENTS AND SPECIFICATIONS	<u>6</u>
3.1	Molex Documents	<u>6</u>
3.2	Industry Documents	<u>6</u>
4.0	ELECTRICAL PERFORMANCE RATINGS	<u>7</u>
4.1	Voltage	<u>7</u>
4.2	Applicable Wires	<u>7</u>
4.3	Maximum Current Rating	<u>7</u>
4.4	Temperature	<u>8</u>
4.5	Durability	<u>8</u>
4.6	Glow Wire	<u>9</u>
5.0	QUALIFICATION	<u>9</u>
6.0	PERFORMANCE	<u>9</u>
6.1	Electrical Performance	<u>9</u>
6.2	Mechanical Performance	<u>10</u>
6.3	Environmental Performance	<u>12</u>
7.0	TEST SEQUENCE GROUPS	<u>14</u>
8.0	SOLDER INFORMATION	<u>16</u>
8.1	Solder Process Temperature	<u>16</u>
8.2	Reflow Solder Profile	<u>16</u>
9.0	PACKAGING	<u>18</u>
10.0	CABLE TIE AND/OR WIRE TWIST LOCATION	<u>18</u>
11.0	POLARIZATION AND KEYING OPTIONS	<u>19</u>

[MOLEX ULTRA-FIT WEB PAGE](#)



TABLE OF CONTENTS

REVISION: C	ECR/ECN INFORMATION: EC No: 668512 DATE: 06/29/2021	TITLE: PRODUCT SPECIFICATION FOR ULTRA-FIT CONNECTOR SYSTEM	SHEET No. 4 of 23
DOCUMENT NUMBER: PS-172323-0001	CREATED / REVISED BY: Dixon.Li	CHECKED BY: JONNY.ZHENG	APPROVED BY: ANSON.YIN

1.0 SCOPE

This Product Specification covers Ultra-Fit 3.50 mm pitch wire to board connector systems with gold and tin plating. Receptacles are terminated with 22 to 16 AWG wire using crimp technology.

2.0 PRODUCT DESCRIPTION

2.1 PRODUCT NAME AND SERIES NUMBER (S)

Table 1 – WIRE-TO-BOARD	
Description	Series Number
Receptacle Crimp Terminal	172253
Receptacle Housing, Single Row	172256
Receptacle Housing, Dual Row	172258
TPA	172264 , 172268
Vertical Header Single Row, Kinked Pins	172286
Vertical Header Single Row, Solder Clips	172287
Vertical Header Dual Row, Kinked Pins	172298
Vertical Header Dual Row, Solder Clips	172299
Right Angle Header Single Row, Solder Clips	172310
Right Angle Header Dual Row, Solder Clips	172316

2.2 DIMENSIONS, MATERIALS, PLATING AND MARKINGS

Dimensions & Plating: See individual sales drawings.
Material: RoHS compliant materials.

2.3 SAFETY AGENCY APPROVALS

2.3.1 UL File Number: E29179

UL (fully loaded) NON-current interruption	Current interruption per UL1977
14 Amps @ 600V (16 AWG wire)	14 Amps @ 48V AC/DC (16 AWG wire)

[MOLEX ULTRA-FIT WEB PAGE](#)



TABLE OF CONTENTS

REVISION: C	ECR/ECN INFORMATION: EC No: 668512 DATE: 06/29/2021	TITLE: PRODUCT SPECIFICATION FOR ULTRA-FIT CONNECTOR SYSTEM	SHEET No. 5 of 23
DOCUMENT NUMBER: PS-172323-0001	CREATED / REVISED BY: Dixon.Li	CHECKED BY: JONNY.ZHENG	APPROVED BY: ANSON.YIN

2.3.2 IEC License Number per IEC / EN 61984: TBD

**IEC (fully loaded)
NON-current interruption**

2.3.3  **File Number*: 70022376 (LR19980)**

CSA approval meets following standards/test procedures:

* “C” and “US” mark adjacent to CSA signifies that the product has been evaluated to the applicable CSA and ANSI/UL standards, for use in Canada and US respectively.

**CSA (single circuit)
NON-current interruption**

14 Amps @ 400V (16 AWG wire)

3.0 APPLICABLE DOCUMENTS AND SPECIFICATIONS

3.1 MOLEX DOCUMENTS

See series specific sales drawings and the other sections of this specifications for the necessary referenced documents and specifications.

- [Ultra-Fit Test Summary TS-172323-0001](#)
- [Ultra-Fit Application Specification AS-172323-0001](#)
- [Ultra-Fit Application Tooling Specification \(Hand Crimp Tool\) ATS-6382753HM](#)
- [Ultra-Fit Application Tooling Specification \(Insertion and Extractor Tool\) ATS-011030016](#)
- [Ultra-Fit Application Tooling Specification \(Fine Adjust Applicator\) ATS-639041600](#)
- [Molex Quality Crimping Handbook Order No. 63800-0029](#)
- [Molex Solderability Specification SMES-152](#)
- [Molex Heat Resistance Specification AS-40000-5013](#)
- [Molex Moisture Technical Advisory AS-45499-001](#)
- [Molex Package Handling Specification 454990100-PK](#)

3.2 INDUSTRY DOCUMENTS

- EIA-364-1000.01
- UL-60950-1
- UL-1977
- CSA STD. C22.2 NO. 182.3-M1987
- IEC / EN 61984
- USCAR-2 REV.6

[MOLEX ULTRA-FIT WEB PAGE](#)



TABLE OF CONTENTS

REVISION:	ECR/ECN INFORMATION:	TITLE:	SHEET No.
C	EC No: 668512 DATE: 06/29/2021	PRODUCT SPECIFICATION FOR ULTRA-FIT CONNECTOR SYSTEM	6 of 23
DOCUMENT NUMBER:	CREATED / REVISED BY:	CHECKED BY:	APPROVED BY:
PS-172323-0001	Dixon.Li	JONNY.ZHENG	ANSON.YIN

4.0 ELECTRICAL PERFORMANCE RATINGS

4.1 VOLTAGE*

600 Volts AC (RMS) or 600 Volts DC max.

* This connector voltage meets the connector level provided by the safety agency. For application voltage requirements per UL-60950 or other standards, the creepage & clearance also needs to be determined based upon pads/traces on the PCB.

4.2 APPLICABLE WIRES

Maximum Insulation Diameter and Applicable Wire Gauges	Stranded copper 16 AWG: 2.00mm MAXIMUM Stranded copper 18 AWG: 1.70mm MAXIMUM Stranded copper 20 AWG: 1.50mm MAXIMUM Stranded copper 22 AWG: 1.30mm MAXIMUM
---	--

4.3 MAXIMUM CURRENT RATING

Current rating is application dependent and may be affected by the wire rating such as listed in UL-60950-1. Each application should be evaluated by the end user for compliance to specific safety agency requirements. The ratings listed in the chart below are per Molex test method based on a 30°C maximum temperature rise over ambient temperature and are provided as a guideline. Appropriate de-rating is required based on circuit size, ambient temperature, copper trace size on the PCB, gross heating from adjacent modules/components and other factors that influence connector performance. Wire size, insulation thickness, stranding, tin coated or bare copper, wire length & crimp quality are other factors that influence current rating.

Wire to Board Current Rating (Amp Max.) (Tested with TIN plated terminals)														
Connector fully loaded with all circuits powered														
AWG Wire Size	Circuit Size (Single Row)							Circuit Size (Dual Row)						
	2	3	4	5	6	7	8	4	6	8	10	12	14	16
16	14.0	12.8*	12.1*	11.5*	11.3*	11.1*	11.0	12.0	11.1*	11.0*	10.5*	10.3*	10.0*	10.0
18	12.6*	11.6*	10.9*	10.4*	9.9*	9.5*	9.2*	10.9*	9.9*	9.2*	8.6*	8.2*	7.8*	7.5*
20	11.5*	10.5*	9.8*	9.2*	8.8*	8.4*	8.1*	9.8*	8.8*	8.1*	7.5*	7.0*	6.7*	6.3*
22	9.0	8.8*	8.6*	8.1*	7.6*	7.3*	7.0	8.0	7.6*	6.9*	6.4*	5.9*	5.5*	5.0

Temperature Rise vs. Current per EIA-364-70

Tested with UL1061 Tinned Wire and PCB with 2oz. Copper Traces of 1.8mm width and 3.5mm length.

*Extrapolated from test data.

[MOLEX ULTRA-FIT WEB PAGE](#)



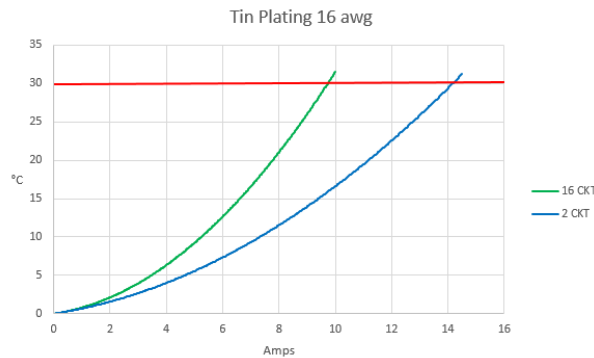
TABLE OF CONTENTS TOC

REVISION: C	ECR/ECN INFORMATION: EC No: 668512 DATE: 06/29/2021	TITLE: PRODUCT SPECIFICATION FOR ULTRA-FIT CONNECTOR SYSTEM	SHEET No. 7 of 23
DOCUMENT NUMBER: PS-172323-0001	CREATED / REVISED BY: Dixon.Li	CHECKED BY: JONNY.ZHENG	APPROVED BY: ANSON.YIN

Wire to Board Current Rating (Amp Max.) (Tested with GOLD plated terminals)														
Connector fully loaded with all circuits powered														
AWG Wire Size	Circuit Size (Single Row)							Circuit Size (Dual Row)						
	2	3	4	5	6	7	8	4	6	8	10	12	14	16
16	12.0	11.2*	11.0*	10.7*	10.5*	10.3*	10.0	11.0	10.0*	9.2*	8.5*	8.0*	7.7*	7.0
18	11.0*	10.1*	9.5*	9.0*	8.6*	8.2*	7.9*	9.5*	8.6*	7.9*	7.4*	7.0*	6.6*	6.3*
20	10.0*	9.1*	8.4*	7.9*	7.5*	7.2*	6.9*	8.4*	7.5*	6.9*	6.4*	6.0*	5.6*	5.3*
22	8.0	7.7*	7.4*	6.9*	6.5*	6.1*	6.0	7.0	6.6*	6.0*	5.7*	5.4*	5.2*	5.0

Temperature Rise vs. Current per EIA-364-70

Tested with UL1061 Tinned Wire and PCB with 2oz. Copper Traces of 1.8mm width and 3.5mm length.
*Extrapolated from test data.



4.4 TEMPERATURE

TIN plated

Max. operating temperature range (including T-rise from applied current) is -40°C to 105°C.

Field temperatures and field life: Tested per EIA 364-1000.01 to meet field temperature of 65°C for 10 years life per table-8.

GOLD plated

Max. operating temperature range (including T-rise from applied current) is -40°C to 120°C, thermal aging at 120°C for 1000 hours.

Field temperatures and field life: Tested per EIA 364-1000.01 to meet field temperature of 85°C for 10 years or 95°C for 7 years life per table-8.

4.5 DURABILITY

Tin plated: 25 mating cycles

Gold plated: 200 mating cycles

As tested in accordance with EIA-364-1000.01 test method (see Sec. 7.0 of this specification). Durability per EIA-364-09

[MOLEX ULTRA-FIT WEB PAGE](#)



TABLE OF CONTENTS

REVISION: C	ECR/ECN INFORMATION: EC No: 668512 DATE: 06/29/2021	TITLE: PRODUCT SPECIFICATION FOR ULTRA-FIT CONNECTOR SYSTEM	SHEET No. 8 of 23
DOCUMENT NUMBER: PS-172323-0001	CREATED / REVISED BY: Dixon.Li	CHECKED BY: JONNY.ZHENG	APPROVED BY: ANSON.YIN

4.6 GLOW WIRE

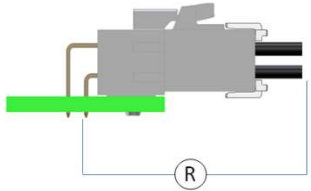
The following series are glow capacity: 172256, 172260, 172258 and 172262, some with TPA and 172286, 172287, 172298, 172299, 172310 and 172316. Representative samples were tested and found compliant with EN 60695-2-11-2001 / IEC 60695-2-11- 2000 Glow Wire Test Methods for End-Products. VDE Test report available upon request.

5.0 QUALIFICATION

Laboratory conditions and sample selection are in accordance with EIA-364-1000.01

6.0 PERFORMANCE

6.1 ELECTRICAL PERFORMANCE

DESCRIPTION	TEST CONDITION	REQUIREMENT
Initial Contact Resistance (Low Level) 	Mate connectors, apply a maximum voltage of 20 mV and a current of 100 mA (measurement locations shown) Per EIA-364-23 Wire resistance and traces shall be removed from the measured value.	Maximum (Initial): Tin: 2 mΩ 15μ" & 30μ" Gold: 3 mΩ
Contact Resistance @Rated Current (Voltage Drop)	Mate connectors; apply the rated current. Per EIA-364-70	Maximum: Tin: 5 mΩ 15μ" & 30μ" Gold: 7 mΩ
Insulation Resistance	Apply 500 VDC between adjacent terminals or ground. Per EIA-364-21	1,000 M Ω minimum
Dielectric Withstanding Voltage	Apply 1800 VAC for 1 minute between adjacent terminals. Per EIA-364-20	No breakdown Current leakage <5mA
Temperature Rise	Mate connectors, measure T- Rise @ Rated Current Per EIA-364-70	Temperature rise: 30°C maximum (see chart) PASS

[MOLEX ULTRA-FIT WEB PAGE](#)



[TABLE OF CONTENTS](#)

REVISION:	ECR/ECN INFORMATION:	TITLE:		SHEET No.
C	EC No: 668512 DATE: 06/29/2021	PRODUCT SPECIFICATION FOR ULTRA-FIT CONNECTOR SYSTEM		9 of 23
DOCUMENT NUMBER:		CREATED / REVISED BY:	CHECKED BY:	APPROVED BY:
PS-172323-0001		Dixon.Li	JONNY.ZHENG	ANSON.YIN

6.2 MECHANICAL PERFORMANCE

ITEM	TEST CONDITION	REQUIREMENT
Connector Mating Force Without Latches	Mate connectors at a rate of 25.4 +/- 6 mm per minute. Per EIA-364-37	Tin plated: 4.5 N MAX. initial mate force per circuit 15μ" & 30μ" Gold plated: 2.8 N MAX. per circuit
Connector Un-mating Force Without Latches	Un-mate connectors with latch disabled at a rate of 25.4 +/- 6 mm per minute. Per EIA-364-37	Tin plated: 4.0 N MAX. initial un-mate force per circuit 15μ" & 30μ" Gold plated: 2.3 N MAX. per circuit
Connector Mating Force Without Terminals	Mate connectors at a rate of 25.4 +/- 6 mm per minute. Per EIA-364-37	8 N MAX.
Thumb Latch Yield Strength	Mate loaded connectors fully. Pull connectors apart at a rate of 25.4 +/- 6 mm per minute.	Locking tang option: 89 N MIN. Tangless option: 60 N MIN.
Durability	Mate connectors 25 cycles for tin plated and 200 cycles for gold plated connectors at a maximum rate of 10 cycles per minute. Per EIA-364-09	Maximum change from initial: Tin: 7 mΩ 15μ" & 30μ" Gold: 3 mΩ
Header Pin Retention Force in Housing	Axial pull force on the vertical header housing away from the PCB at a rate of 25.4 +/- 6 mm per minute.	Push from mating side: 50N MIN. Push from PCB side: 10N MIN.

[MOLEX ULTRA-FIT WEB PAGE](#)



[TABLE OF CONTENTS](#)

REVISION: C	ECR/ECN INFORMATION: EC No: 668512 DATE: 06/29/2021	TITLE: PRODUCT SPECIFICATION FOR ULTRA-FIT CONNECTOR SYSTEM	SHEET No. 10 of 23
DOCUMENT NUMBER: PS-172323-0001	CREATED / REVISED BY: Dixon.Li	CHECKED BY: JONNY.ZHENG	APPROVED BY: ANSON.YIN

6.2 MECHANICAL PERFORMANCE (CONT.)		
ITEM	TEST CONDITION	REQUIREMENT
PCB Peg Insertion Force into the PCB (Right Angle Header)	Insert a header at a rate of 25.4±6 mm/minute. (Applies to parts with PCB retention pegs only)	Header with 2 pegs: 35 N MAX insertion force Headers with 1 peg: 23 N MAX insertion force
PCB Peg Retention Force to the PCB (Right Angle Header)	Insert a header at a rate of 25.4±6 mm/minute. (Applies to parts with PCB retention pegs only)	Header with 2 pegs: 0.2 N MIN retention force Headers with 1 peg: 0.1 N MIN retention force
Header Insertion Force into the PCB (Vertical Header)	Insert a header at a rate of 25.4±6 mm/minute.	With Kinked Pins: 35 N MAX. With Solder Clip: 25 N MAX.
Header Retention Force to the PCB (Vertical Header)	Remove a header at a rate of 25.4±6 mm/minute.	With Kinked Pins: 1 N MIN. With Solder Fork: 1 N MIN.
Crimp Terminal Retention Force (in housing)	Axial pullout force on the terminal in the housing at a rate of 25 ± 6 mm per minute. Per EIA-364-29	27 N MINIMUM retention force
Wire Pull Out Force From Terminal (Axial)	Apply an axial pullout force on the wire at a rate of 25 ± 6 mm per minute.	16AWG – 68.4N MIN 18AWG – 68.4N MIN 20AWG – 57.9N MIN 22AWG – 35.6N MIN Reference Molex Application Tooling Specification for Molex crimp tooling being used.
Vibration (Random)	Mate connectors and vibrate per EIA-364-28 test condition VII-D Tin: 15 minutes each axis. Gold: 1.5 hours each axis.	Maximum Change from Initial: Tin: 7 mΩ 15μ" & 30μ" Gold: 3 mΩ Discontinuity < 1 microsecond

[MOLEX ULTRA-FIT WEB PAGE](#)



[TABLE OF CONTENTS](#) [STOC](#)

REVISION: C	ECR/ECN INFORMATION: EC No: 668512 DATE: 06/29/2021	TITLE: PRODUCT SPECIFICATION FOR ULTRA-FIT CONNECTOR SYSTEM	SHEET No. 11 of 23
DOCUMENT NUMBER: PS-172323-0001	CREATED / REVISED BY: Dixon.Li	CHECKED BY: JONNY.ZHENG	APPROVED BY: ANSON.YIN

6.2 MECHANICAL PERFORMANCE (CONT.)

ITEM	ITEM	ITEM
Vibration per USCAR-2 Class V1, S1, T2	Mate connectors, mounted and vibrate as per USCAR-2 Rev6: 5.4.6 Class V1, S1, T2. Random Duration: 8hrs/axis	Maximum Change from Initial: Tin: 7 mΩ 15μ" & 30μ" Gold: 3 mΩ
Reseating	Unmate/Mate connectors by hand three cycles	Maximum Change from Initial: Tin: 7 mΩ 15μ" & 30μ" Gold: 3 mΩ

6.3 ENVIRONMENTAL PERFORMANCE*

ITEM	TEST CONDITION	REQUIREMENT
Thermal Shock	Mate connectors, expose to 10 cycles from -55°C to 85°C Per EIA-364-32 method A, condition 1	Maximum Change from Initial: Tin: 7 mΩ 15μ" & 30μ" Gold: 3 mΩ
Thermal Aging	Tin Mate Connectors, expose to 240 hours at 105°C Per EIA-364-17 Method A Au 1,100 hours at 120°C	Maximum Change from Initial: Tin: 7 mΩ 15μ" & 30μ" Gold: 3 mΩ
Thermal Aging Precondition	Tin & Au 120hrs at 105°C Per EIA-364-17 method A	Maximum Change from Initial: Tin: 7 mΩ 15μ" & 30μ" Gold: 3 mΩ

[MOLEX ULTRA-FIT WEB PAGE](#)



[TABLE OF CONTENTS](#)

REVISION: C	ECR/ECN INFORMATION: EC No: 668512 DATE: 06/29/2021	TITLE: PRODUCT SPECIFICATION FOR ULTRA-FIT CONNECTOR SYSTEM	SHEET No. 12 of 23
DOCUMENT NUMBER: PS-172323-0001	CREATED / REVISED BY: Dixon.Li	CHECKED BY: JONNY.ZHENG	APPROVED BY: ANSON.YIN

6.3 ENVIRONMENTAL PERFORMANCE* (CONT.)		
ITEM	TEST CONDITION	REQUIREMENT
Cyclic Temperature And Humidity	Mate connectors: expose to 24 cycles from 25 °C / 80% RH to 65 °C / 50% RH ramp time: 0.5hr dwell time: 1hr Per EIA-364-31	Maximum Change from Initial: Tin: 7 mΩ 15μ" & 30μ" Gold: 3 mΩ
Solderability Dip Test	Per Molex test method: SMES-152	Solder area shall have MIN. of 95% solder coverage (PASS)
Reflow Solder Resistance	Convection reflow solder process 260°C Max per AS-40000-5013	Visual: No damage
Wave Solder Resistance	Dip header terminal tails in solder: Duration: 5±0.5 seconds Solder temperature: 260±5° C Per AS-40000-5013	Visual: No damage
Thermal Cycling Tin Plated Only	Per EIA-364-1000.01 Test Group 5: Cycle mated connector between 15°C±3°C and 85°C±3°C as measured on the part. Ramps should be a minimum of 2°C per minute, and dwell times should insure contacts reach the temperature extremes (minimum of 5 minutes). Humidity is not controlled. Perform 500 cycles.	Maximum Change from Initial: Tin: 7 mΩ

*Environmental tests have been performed per EIA-364-100.01 except where noted.

[MOLEX ULTRA-FIT WEB PAGE](#)

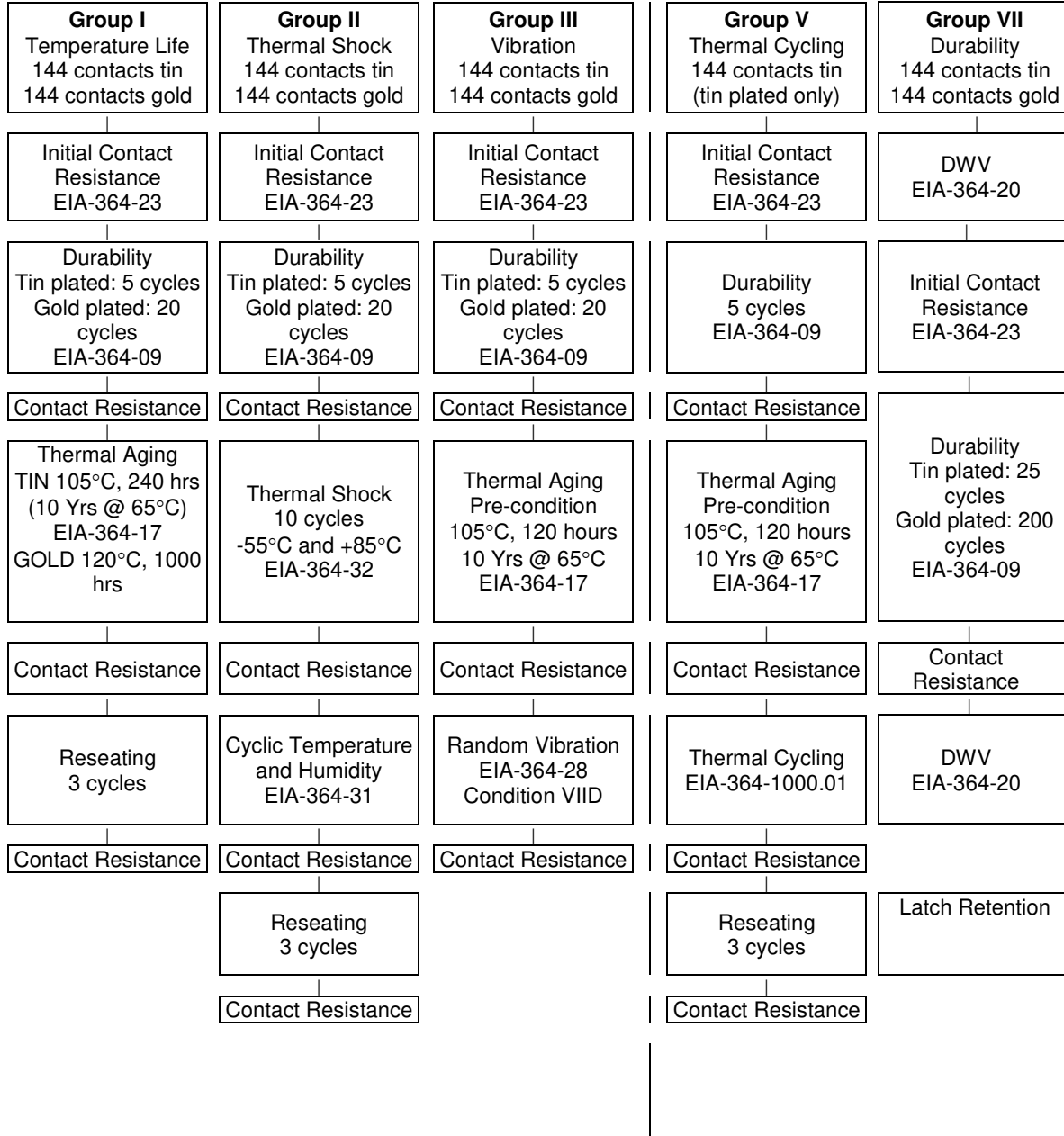


[TABLE OF CONTENTS](#)

REVISION: C	ECR/ECN INFORMATION: EC No: 668512 DATE: 06/29/2021	TITLE: PRODUCT SPECIFICATION FOR ULTRA-FIT CONNECTOR SYSTEM	SHEET No. 13 of 23
DOCUMENT NUMBER: PS-172323-0001	CREATED / REVISED BY: Dixon.Li	CHECKED BY: JONNY.ZHENG	APPROVED BY: ANSON.YIN

7.0 TEST SEQUENCE GROUPS

Reliability Test Sequences Per 364-1000.01

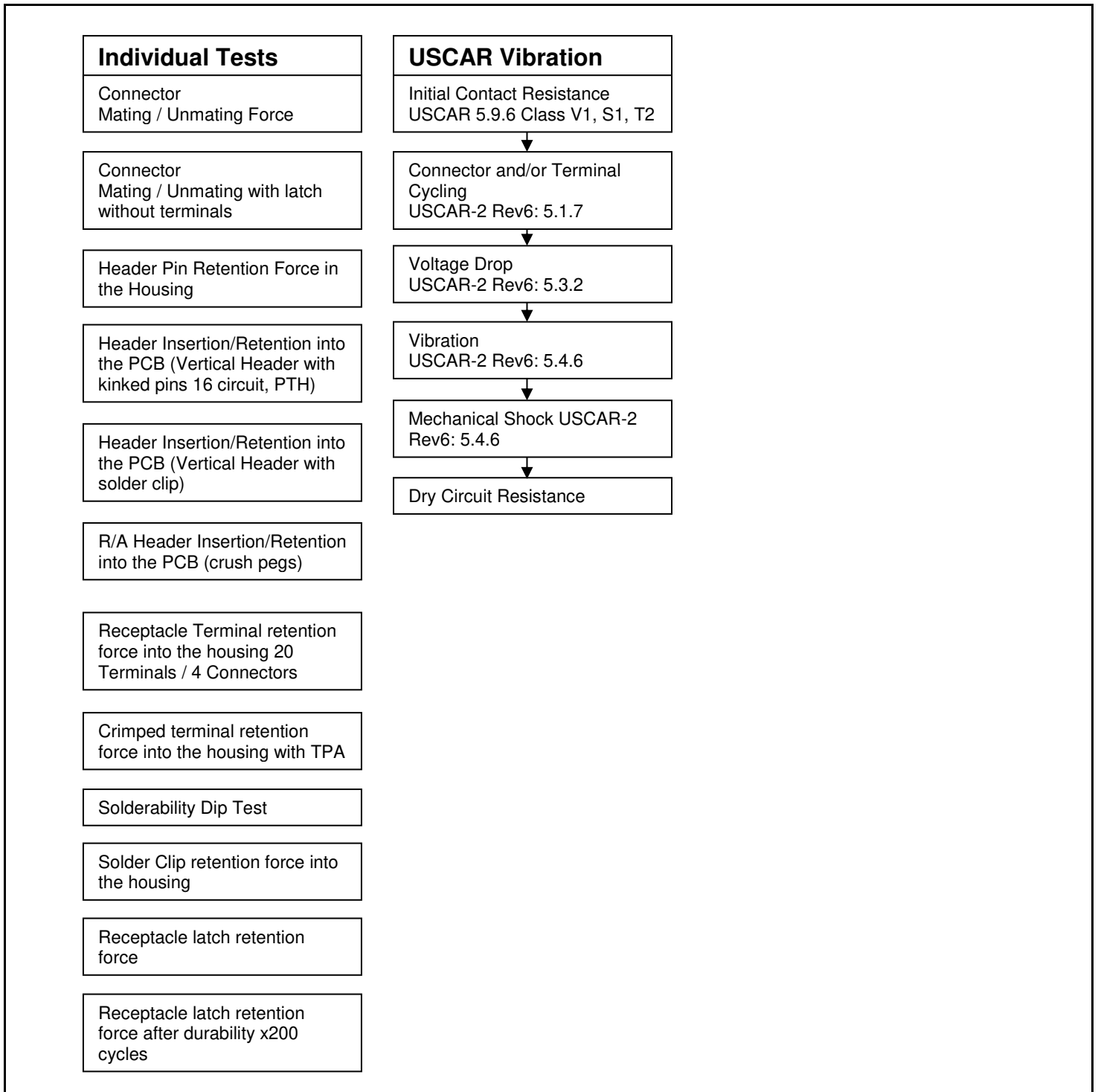


[MOLEX ULTRA-FIT WEB PAGE](#)



TABLE OF CONTENTS

REVISION: C	ECR/ECN INFORMATION: EC No: 668512 DATE: 06/29/2021	TITLE: PRODUCT SPECIFICATION FOR ULTRA-FIT CONNECTOR SYSTEM	SHEET No. 14 of 23
DOCUMENT NUMBER: PS-172323-0001	CREATED / REVISED BY: Dixon.Li	CHECKED BY: JONNY.ZHENG	APPROVED BY: ANSON.YIN



[MOLEX ULTRA-FIT WEB PAGE](#)



TABLE OF CONTENTS

REVISION: C	ECR/ECN INFORMATION: EC No: 668512 DATE: 06/29/2021	TITLE: PRODUCT SPECIFICATION FOR ULTRA-FIT CONNECTOR SYSTEM	SHEET No. 15 of 23
DOCUMENT NUMBER: PS-172323-0001	CREATED / REVISED BY: Dixon.Li	CHECKED BY: JONNY.ZHENG	APPROVED BY: ANSON.YIN

8.0 SOLDER INFORMATION

[Molex Solderability Specification SMES-152](#)

[\(Click Here\)](#)

8.1 SOLDER PROCESS TEMPERATURES

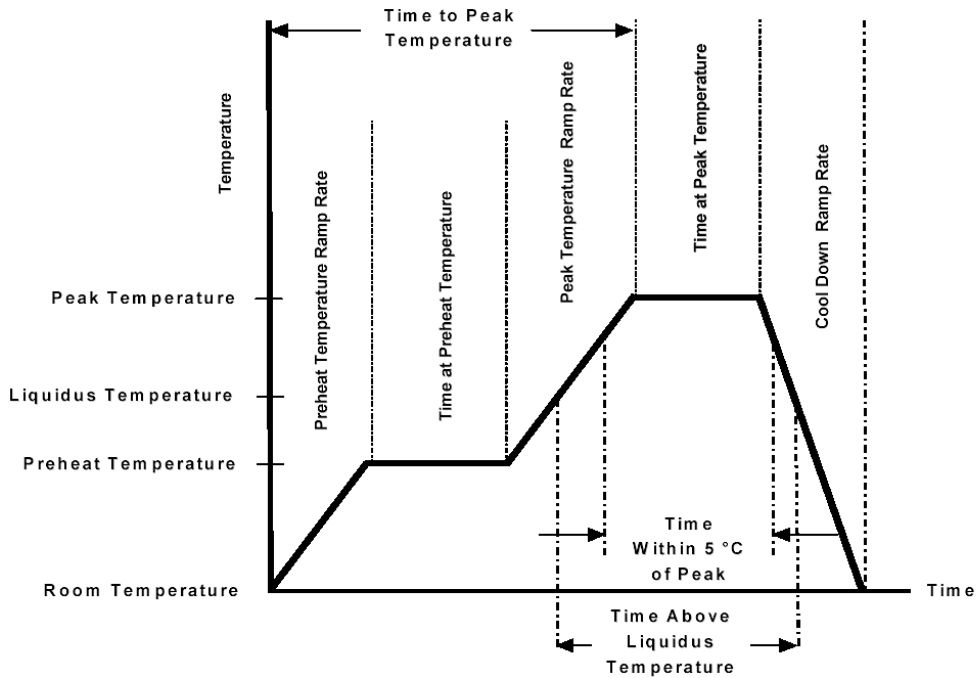
Wave Solder: 265°C Max
Reflow Solder: 260°C Max

8.2 REFLOW SOLDERING PROFILE

(This profile is per AS-40000-5013 and is provided as a guideline only. Please see notes for additional information)

[Molex Connector Heat Resistance Specification AS-40000-5013](#)

[\(Click Here\)](#)



[MOLEX ULTRA-FIT WEB PAGE](#)



[TABLE OF CONTENTS](#)

REVISION: C	ECR/ECN INFORMATION: EC No: 668512 DATE: 06/29/2021	TITLE: PRODUCT SPECIFICATION FOR ULTRA-FIT CONNECTOR SYSTEM	SHEET No. 16 of 23
DOCUMENT NUMBER: PS-172323-0001	CREATED / REVISED BY: Dixon.Li	CHECKED BY: JONNY.ZHENG	APPROVED BY: ANSON.YIN

Description	Requirement
Average Ramp Rate	3°C/sec Max
Preheat Temperature	150°C Min to 200°C Max
Preheat Time	60 to 180 sec
Ramp to Peak	3°C/sec Max
Time over Liquidus (217°C)	60 to 150 sec
Peak Temperature	260 +0/-5°C
Time within 5°C of Peak	20 to 40 sec
Ramp - Cool Down	6°C/sec Max
Time 25°C to Peak	8 min Max

Notes:

1. Temperature indicated refers to the PCB surface temperature at solder tail area.
2. Connector can withstand 1 reflow cycle.
3. Actual reflow profile also depends on equipment, solder paste, PCB thickness, and other components on the board. Please consult your solder paste & reflow equipment manufacturer for their recommendations to adopt a suitable process.

[MOLEX ULTRA-FIT WEB PAGE](#)



[TABLE OF CONTENTS TOC](#)

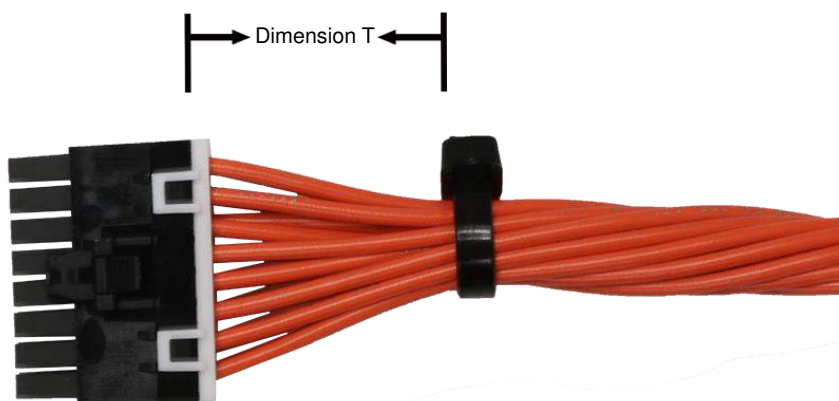
REVISION: C	ECR/ECN INFORMATION: EC No: 668512 DATE: 06/29/2021	TITLE: PRODUCT SPECIFICATION FOR ULTRA-FIT CONNECTOR SYSTEM	SHEET No. 17 of 23
DOCUMENT NUMBER: PS-172323-0001	CREATED / REVISED BY: Dixon.Li	CHECKED BY: JONNY.ZHENG	APPROVED BY: ANSON.YIN

9.0 PACKAGING

Parts shall be packaged to protect against damage during normal handling, transit and storage. Refer Molex.com specific part number webpage to get the exact packaging document for that item.

10.0 CABLE TIE AND/OR WIRE TWIST LOCATION

Circuit Sizes			Dimension T Minimum
2	4	6	0.50" (12.7mm)
8			0.75" (19.1mm)
10	12		1.00" (25.40mm)
14	16		1.25" (31.75mm)
18	20		1.50" (38.09mm)
22	24		1.75" (44.45mm)



The “T” dimension defines a “free” length of wire, or a length of wire that is not subject to significant bias by external factors such as a wire tie, wire twisting, or other means of bending or deforming of the wires that repositions them from their natural relaxed state or location where they enter the housing. Wires are to be dressed in such a manner to allow the terminals to float freely in the pocket. This dimension is general recommendation and may need to be adjusted for different wire gauges and wire type and insulation thickness and insulation material.

[MOLEX ULTRA-FIT WEB PAGE](#)

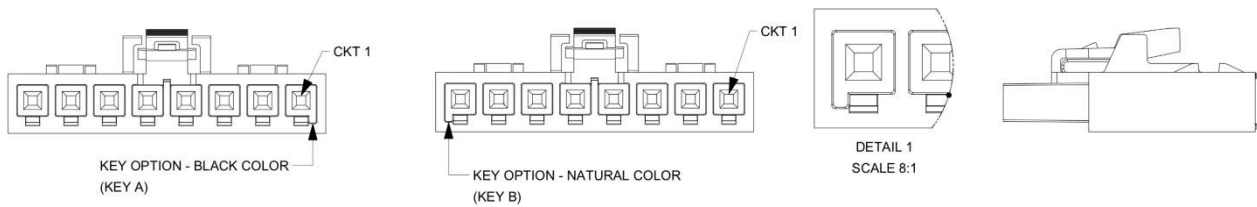


[TABLE OF CONTENTS](#)

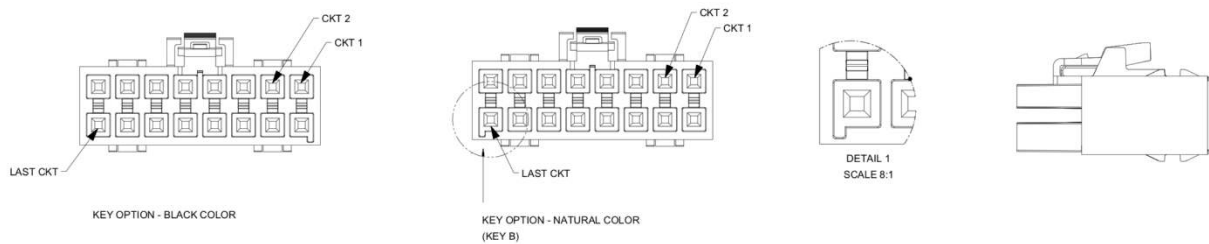
REVISION: C	ECR/ECN INFORMATION: EC No: 668512 DATE: 06/29/2021	TITLE: PRODUCT SPECIFICATION FOR ULTRA-FIT CONNECTOR SYSTEM	SHEET No. 18 of 23
DOCUMENT NUMBER: PS-172323-0001	CREATED / REVISED BY: Dixon.Li	CHECKED BY: JONNY.ZHENG	APPROVED BY: ANSON.YIN

11.0 POLARIZATION AND KEYING OPTIONS

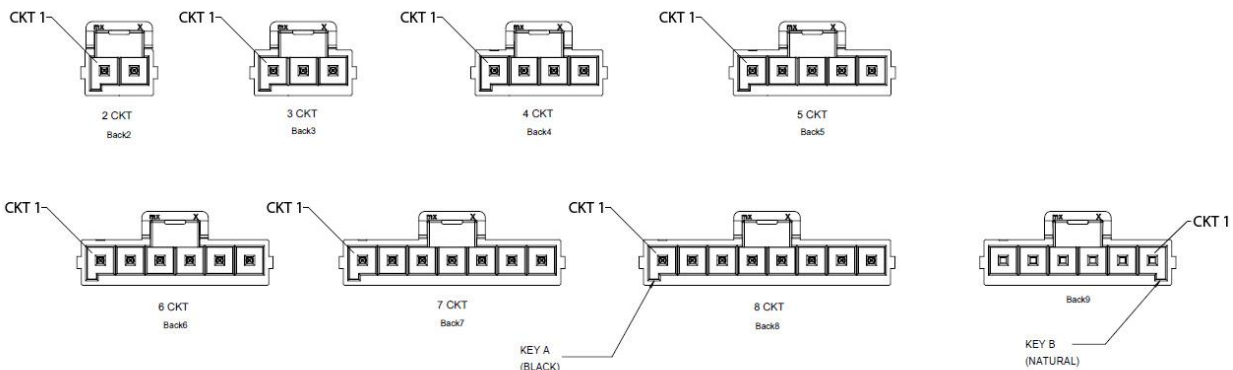
11.1 Single Row Receptacle (Series: [172256](#))



11.2 Dual Row Receptacle (Series: [172258](#))



11.3 Vertical Header Single Row Kinked Pins (Series: [172286](#))



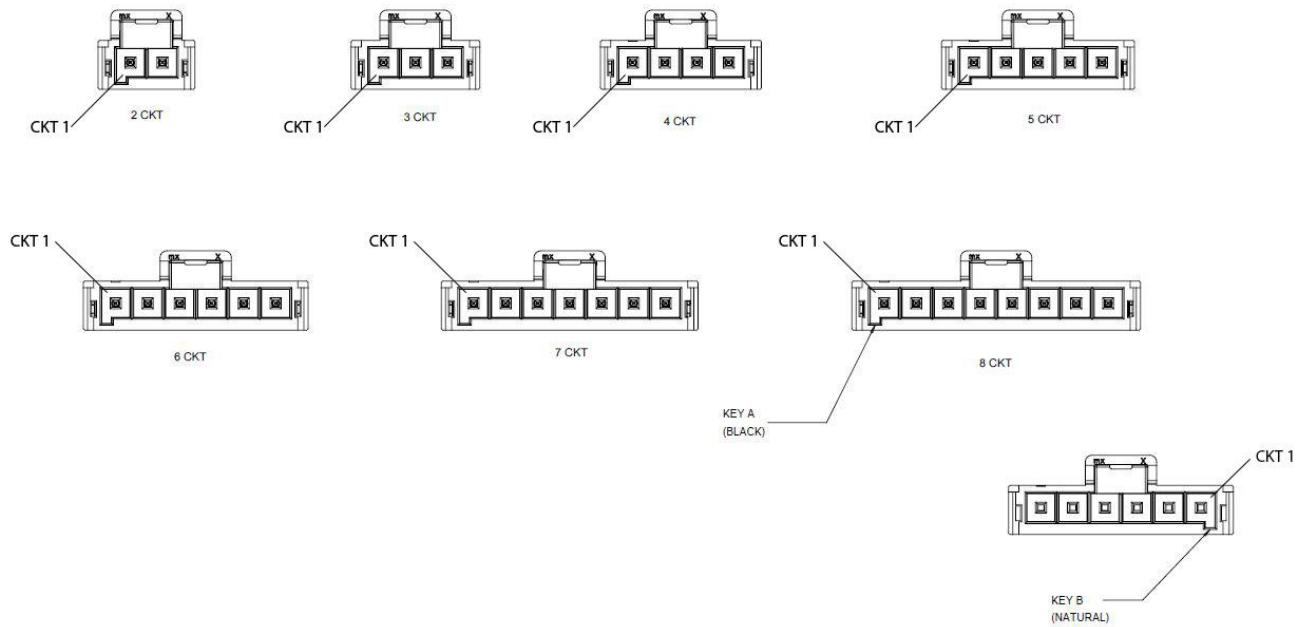
[MOLEX ULTRA-FIT WEB PAGE](#)



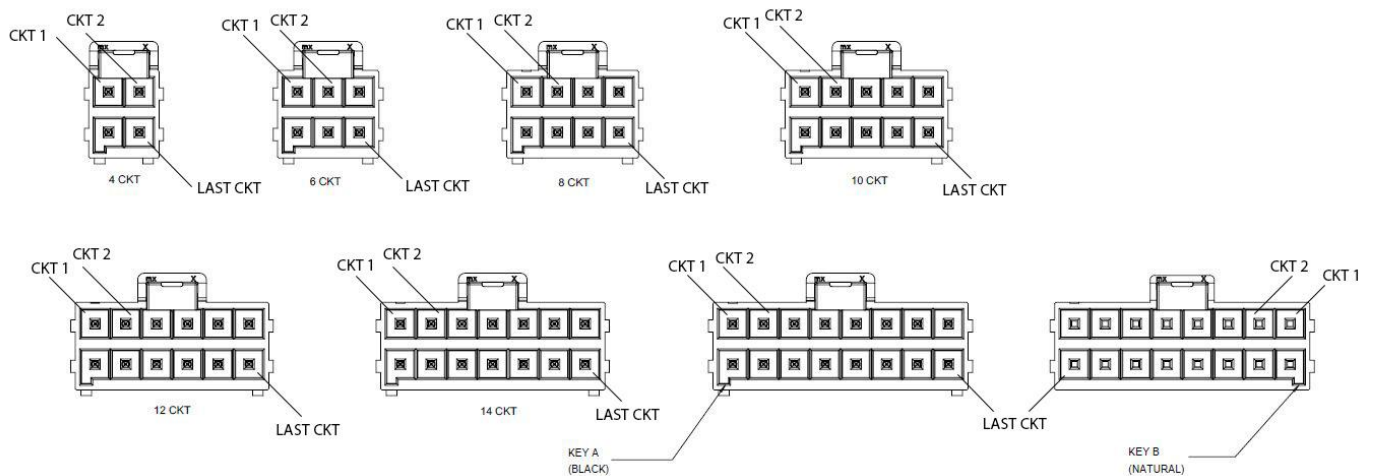
TABLE OF CONTENTS

REVISION: C	ECR/ECN INFORMATION: EC No: 668512 DATE: 06/29/2021	TITLE: PRODUCT SPECIFICATION FOR ULTRA-FIT CONNECTOR SYSTEM	SHEET No. 19 of 23
DOCUMENT NUMBER: PS-172323-0001	CREATED / REVISED BY: Dixon.Li	CHECKED BY: JONNY.ZHENG	APPROVED BY: ANSON.YIN

11.4 Vertical Header Single Row Solder Clip (Series: [172287](#))



11.5 Vertical Header Dual Row Kinked Pins (Series: [172298](#))



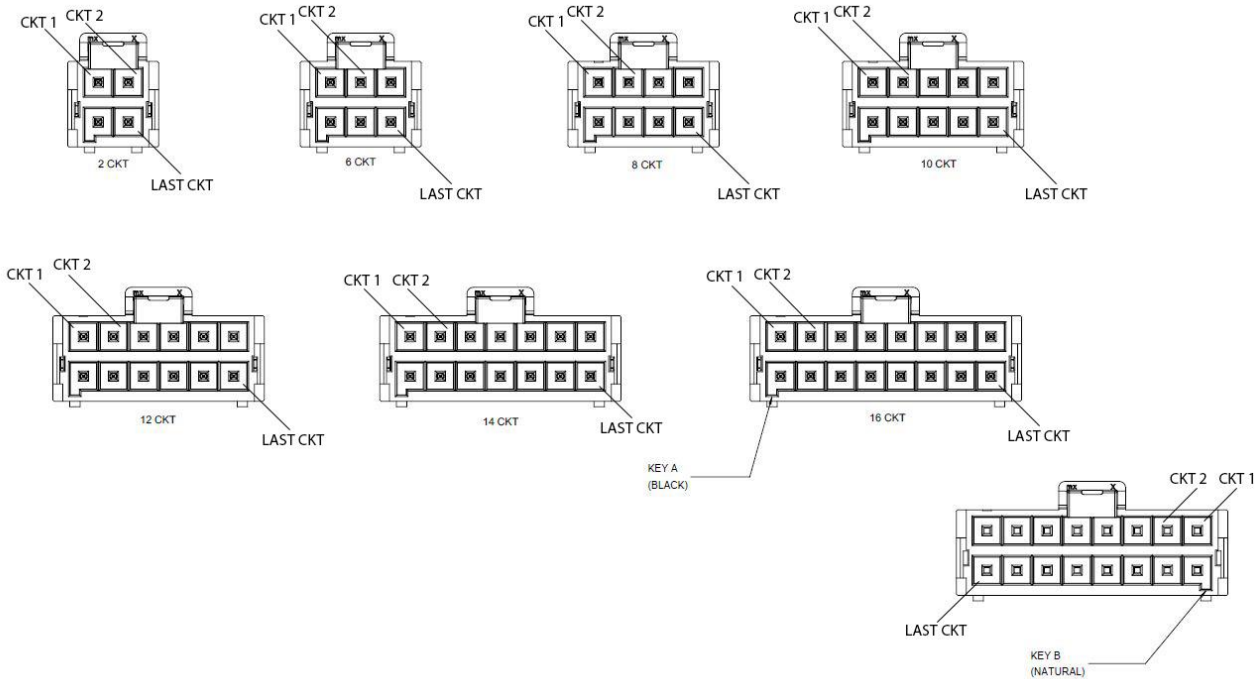
[MOLEX ULTRA-FIT WEB PAGE](#)



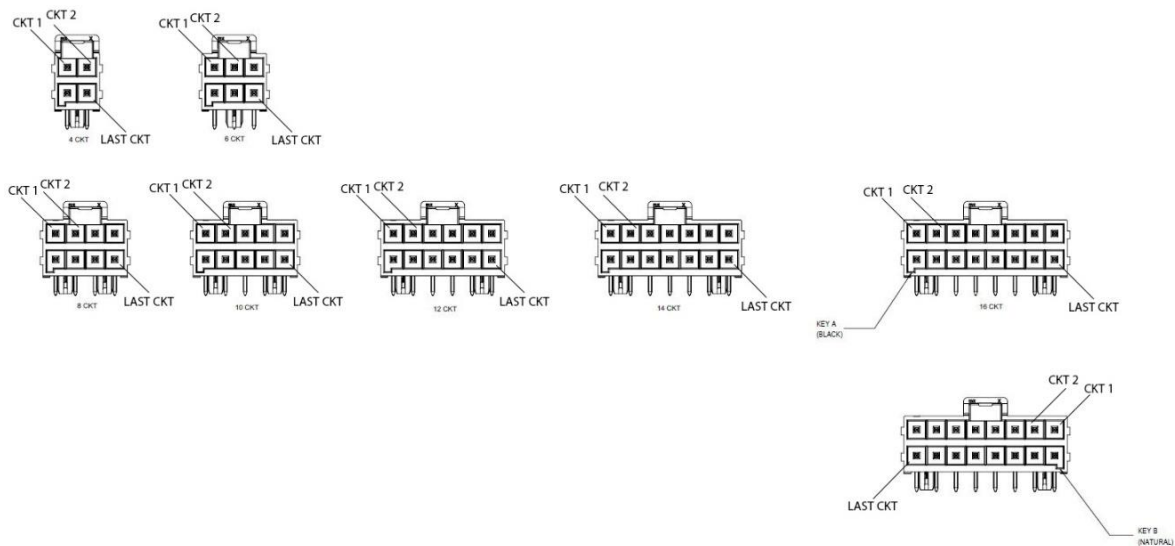
[TABLE OF CONTENTS](#)

REVISION: C	ECR/ECN INFORMATION: EC No: 668512 DATE: 06/29/2021	TITLE: PRODUCT SPECIFICATION FOR ULTRA-FIT CONNECTOR SYSTEM	SHEET No. 20 of 23
DOCUMENT NUMBER: PS-172323-0001	CREATED / REVISED BY: Dixon.Li	CHECKED BY: JONNY.ZHENG	APPROVED BY: ANSON.YIN

11.6 Vertical Header Dual Row Solder Clip (Series: [172299](#))



11.7 Right Angle Header Dual Row (Series: [172316](#))



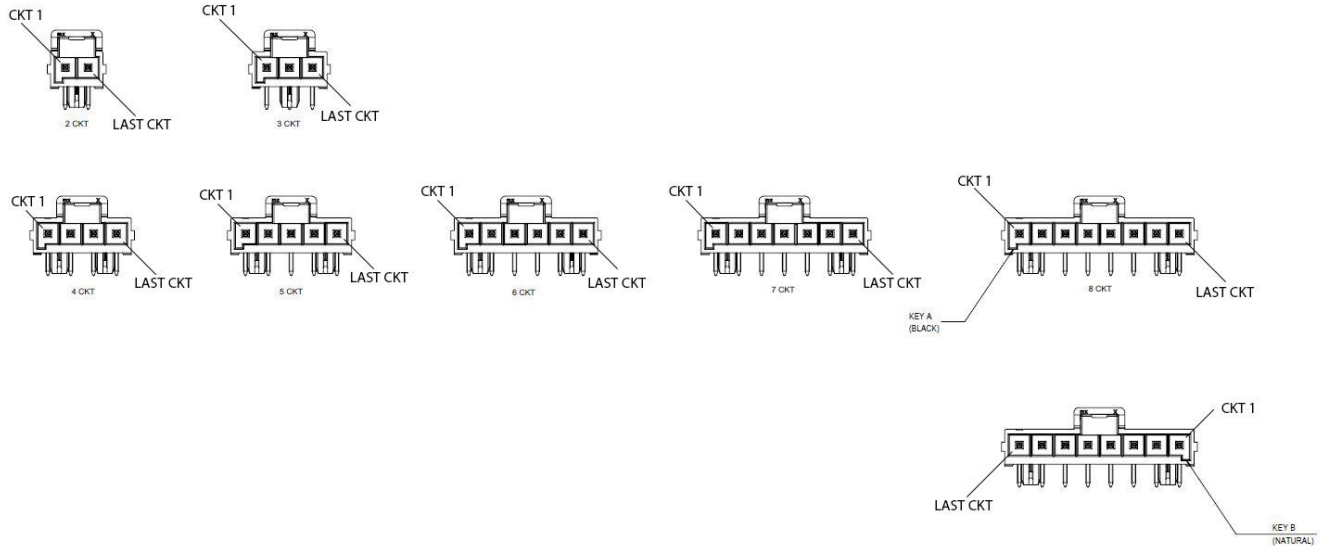
[MOLEX ULTRA-FIT WEB PAGE](#)



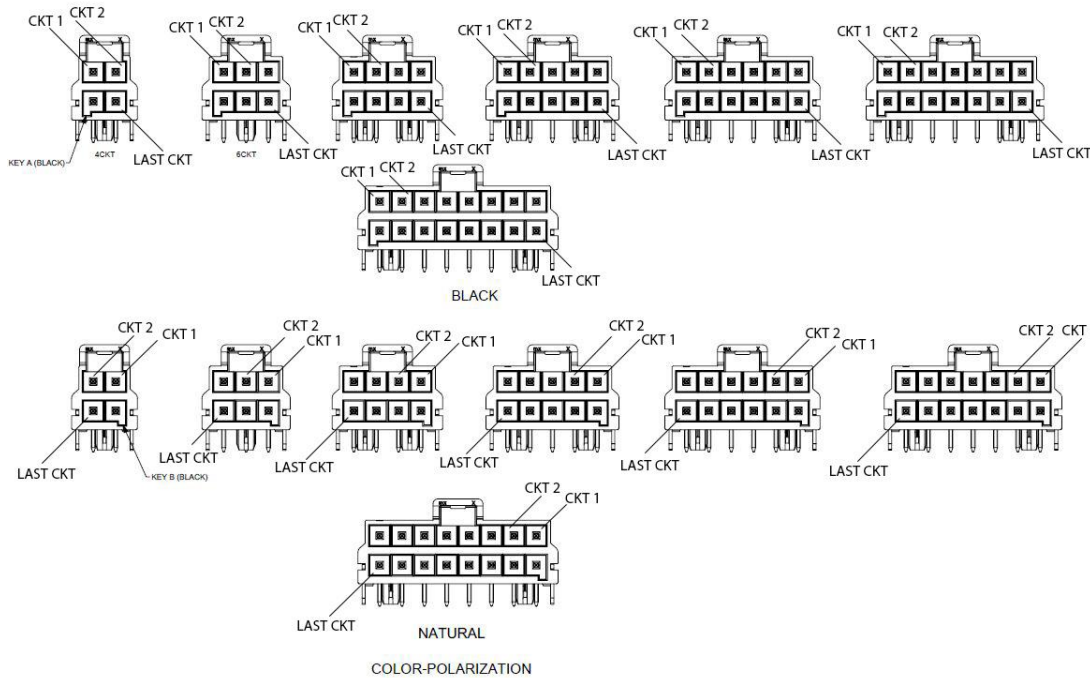
[TABLE OF CONTENTS](#)

REVISION: C	ECR/ECN INFORMATION: EC No: 668512 DATE: 06/29/2021	TITLE: PRODUCT SPECIFICATION FOR ULTRA-FIT CONNECTOR SYSTEM	SHEET No. 21 of 23
DOCUMENT NUMBER: PS-172323-0001	CREATED / REVISED BY: Dixon.Li	CHECKED BY: JONNY.ZHENG	APPROVED BY: ANSON.YIN

11.8 Right Angle Header Single Row (Series: [172310](#))



11.9 Right Angle Header Dual Row Solder Nail (Series: [172316](#))



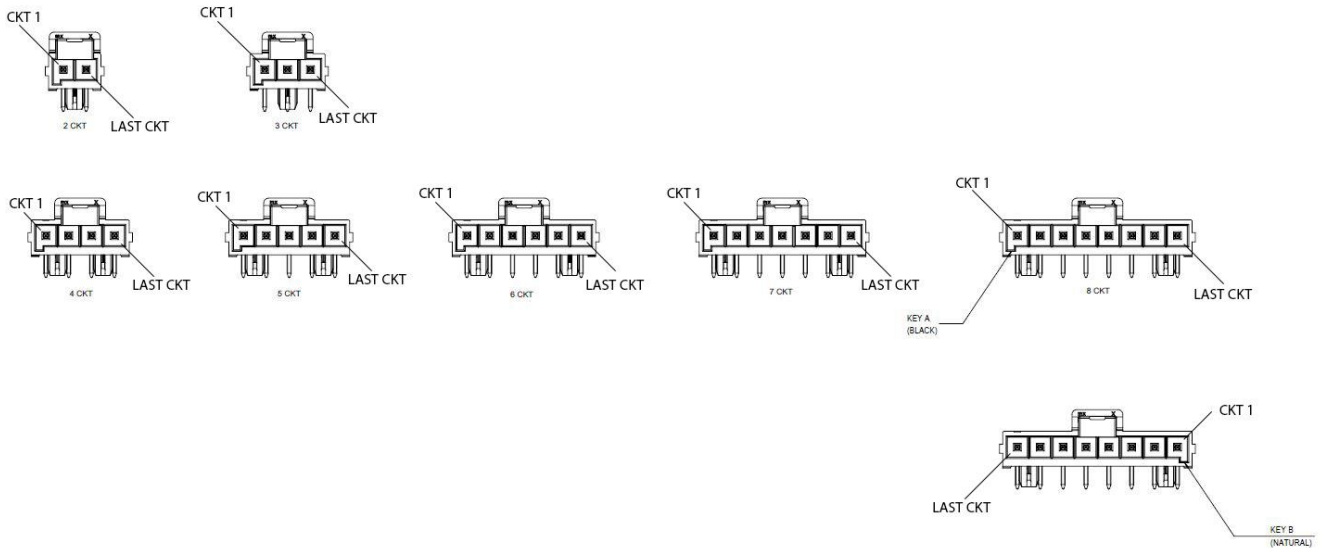
[MOLEX ULTRA-FIT WEB PAGE](#)



[TABLE OF CONTENTS](#)

REVISION: C	ECR/ECN INFORMATION: EC No: 668512 DATE: 06/29/2021	TITLE: PRODUCT SPECIFICATION FOR ULTRA-FIT CONNECTOR SYSTEM	SHEET No. 22 of 23
DOCUMENT NUMBER: PS-172323-0001	CREATED / REVISED BY: Dixon.Li	CHECKED BY: JONNY.ZHENG	APPROVED BY: ANSON.YIN

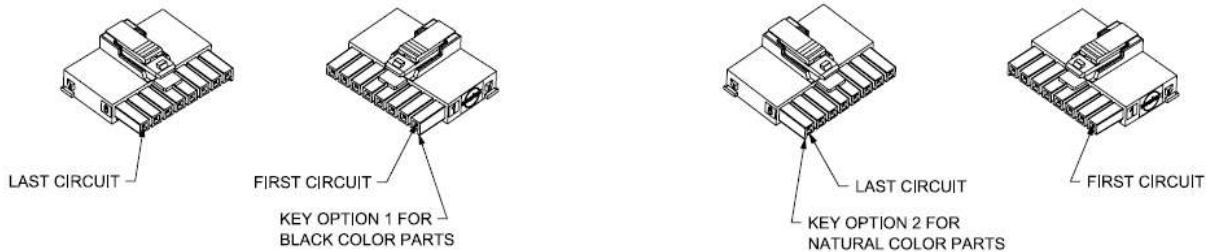
11.10 Right Angle Header Single Row Solder Nail (Series: [172310](#))



11.11 Tangless Receptacle Housing Single Row (Series: [172256](#))

KEY OPTION 1

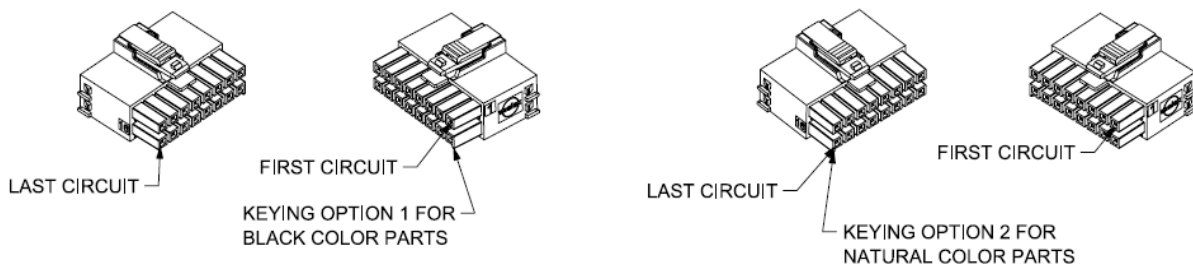
KEY OPTION 2



11.12 Tangless Receptacle Dual Row Housing (Series: [172258](#))

KEYING OPTION 1

KEYING OPTION 2



[MOLEX ULTRA-FIT WEB PAGE](#)



[TABLE OF CONTENTS TOC](#)

REVISION: C	ECR/ECN INFORMATION: EC No: 668512 DATE: 06/29/2021	TITLE: PRODUCT SPECIFICATION FOR ULTRA-FIT CONNECTOR SYSTEM	SHEET No. 23 of 23
DOCUMENT NUMBER: PS-172323-0001	CREATED / REVISED BY: Dixon.Li	CHECKED BY: JONNY.ZHENG	APPROVED BY: ANSON.YIN