

P	LTR	DESCRIPTION	DATE	DWN	APVD
	H2	REVISED PER ECN-22-156403	03JUN2022	RK	CSD

AMP WIRE RANGE	 LR7189 Certified
16-14 AWG STRANDED	WIRE SIZE PER STRANDED STRANDED

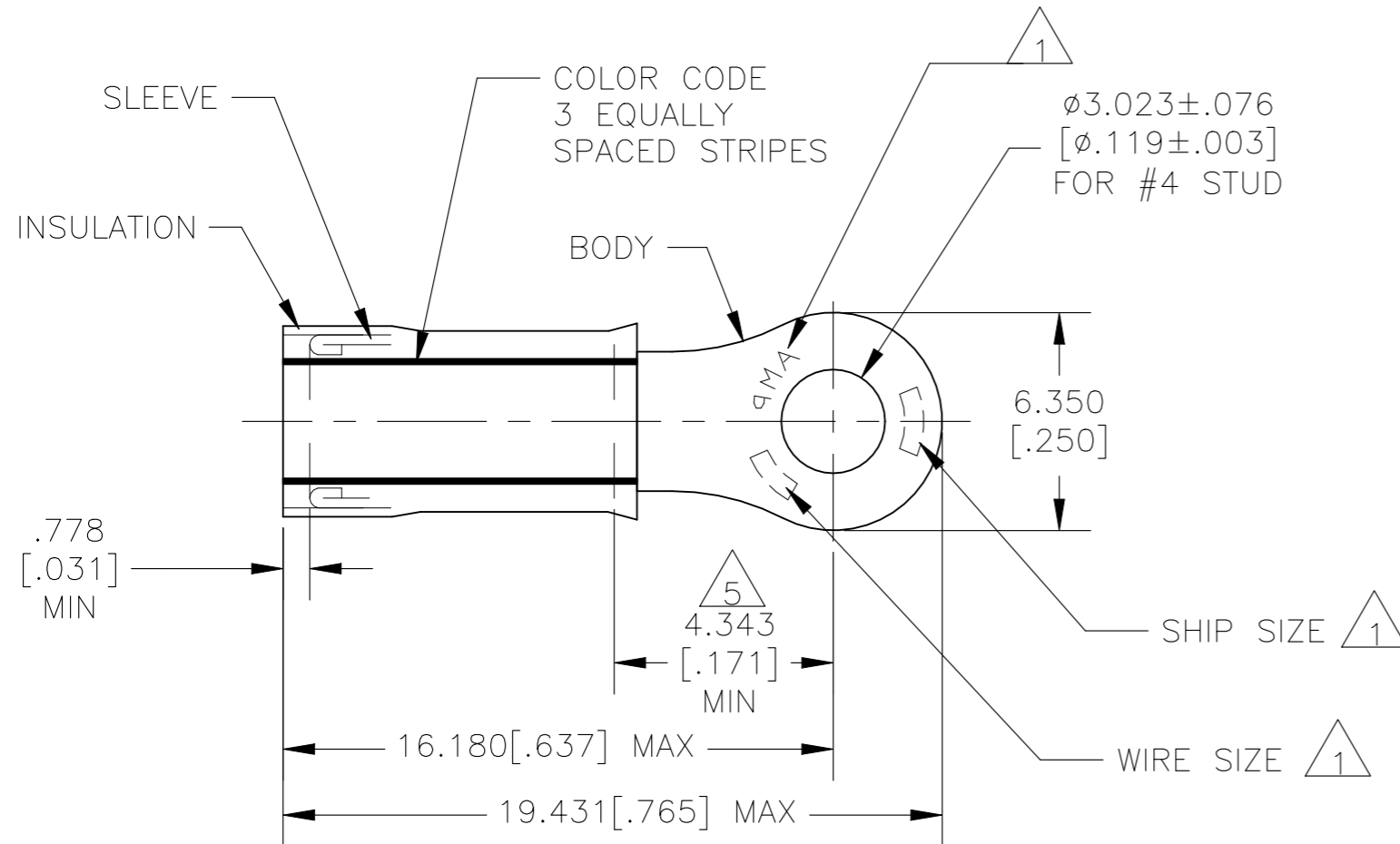

- 1 STAMP "AMP []", SEE TABLE APPROX AS SHOWN.
- 2 WIRE INSULATION DIA: SEE TABLE.
- 3 BODY MATERIAL THK: 0.787[.031]±0.051[.002].
- 4 BODY & SLEEVE: CU PER ASTM B152
BODY & SLEEVE: TIN PLATE .000100 MIN
EXT THK PER ASTM B545
INSULATION: NYLON PER ASTM D4066,
COLOR-BLUE.
- 5 APPLIES FROM EDGE OF METAL WIRE BARREL
TO CENTER OF STUD HOLE.
- 6 MEETS M7928/1-38, CLASS 1.
- 7 MEETS M7928/1-47, CLASS 1.

52274-1	14	GREEN	1.981[.078]-3.312[.130]	14*	4
52274	16	BLUE	1.600[.063]-3.302[.130]	16*	2 1/2
PART NO	WIRE SIZE	COLOR CODE	INSULATION DIA	WIRE STAMPING	SHIP SIZE

500	LOOSE PIECE	4	7	52274-1
500	LOOSE PIECE	4	6	52274
QTY	PACKAGE TYPE	MATERIAL FINISH	PART NO	

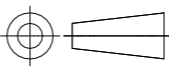
CUSTOMER SERVICE SYSTEMS		MAX RECOMMENDED OPERATING TEMPERATURE: 105°C[221°F] MAX	THIS DRAWING IS A CONTROLLED DOCUMENT.		DWN JR RUTH 13JAN10	 TE Connectivity			
FOR ADDITIONAL PRODUCT INFORMATION OR COPIES OF DRAWINGS AND TECHNICAL DOCUMENTS	PRODUCT INFORMATION CENTER 1-800-522-6752	VOLTAGE RATING: 300 V MAX	DIMENSIONS: mm[INCHES]	TOLERANCES UNLESS OTHERWISE SPECIFIED:	CHK T MICHELUTTI 13JAN10				NAME
FOR APPLICATION TOOLING INFORMATION	TOOLING ASSISTANCE CENTER 1-800-722-1111	CIRCULAR MIL AREA: 1.04-2.62mm²[2,050-5,180] STRANDED OR SOLID		0 PLC ± - 1 PLC ± - 2 PLC ± - 3 PLC ± 0.127[.005] 4 PLC ± - ANGLES ± -	APVD T MICHELUTTI 13JAN10	PRODUCT SPEC			
FOR ORDER ENTRY	1-800-526-5142		MATERIAL SEE TABLE	FINISH SEE TABLE	APPLICATION SPEC 114-2157	SIZE A3	CAGE CODE 00779	DRAWING NO C-52274	RESTRICTED TO
					WEIGHT -	CUSTOMER DRAWING			SCALE 5:1
					SHEET 1 OF 1		REV H2		