



May. 2022 Ver.2.0a
TDK Corporation

Multilayer Triplexer

For 617-2690MHz / 3300-3800MHz / 4400-5000MHz

TPX Series 2.5x2.0mm [EIA 1008] TYPE

P/N: **TPX255000MT-7066A1**

TPX255000MT-7066A1

■ SHAPES AND DIMENSIONS

[Top View]

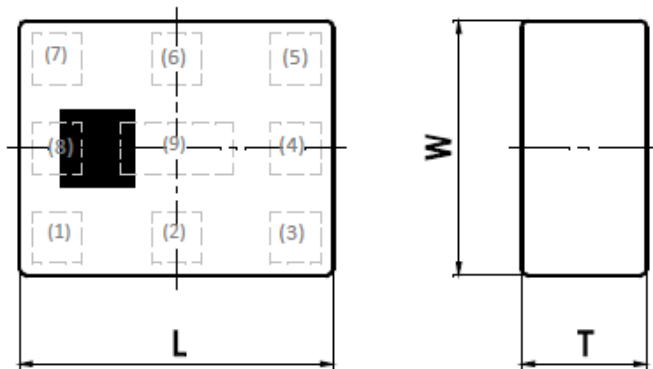

[Bottom View]

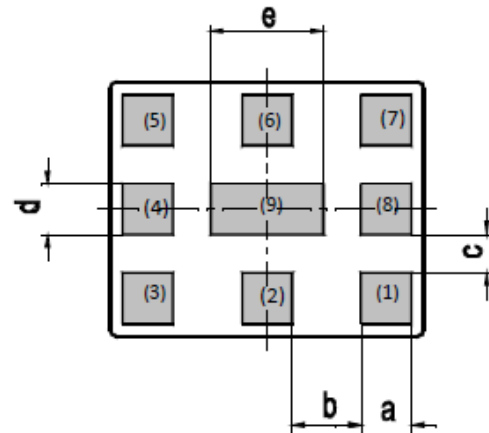

Dimensions (mm)

L	W	T	a	b	c	d	e
2.50	2.00	0.65	0.40	0.55	0.30	0.40	0.90
+/-0.15	+/-0.15	Max	+/-0.10	+/-0.10	+/-0.10	+/-0.10	+/-0.15

Terminal functions

(1)	Common Port
(2)	GND
(3)	High-Band Port
(4)	GND
(5)	Middle-Band Port

(6)	GND
(7)	Low-Band Port
(8)	GND
(9)	GND

■ TERMINATION FINISH

Material
Ag

TPX255000MT-7066A1

ELECTRICAL CHARACTERISTICS

(Measurement)

Low-Band

Parameter	Frequency (MHz)	TDK Spec		
		Min.	Typ.	Max.
Insertion Loss (dB)	617 to 960	-	0.32	0.50
	1166 to 1606	-	0.39	0.55
	1710 to 1785	-	0.36	0.50
	1805 to 1885	-	0.34	0.50
	1930 to 1990	-	0.32	0.50
	2300 to 2496	-	0.48	0.70
	2496 to 2690	-	0.81	1.20
Insertion Loss (dB) (-40 to +90 °C)	617 to 960	-	-	0.60
	1166 to 1606	-	-	0.65
	1710 to 1785	-	-	0.60
	1805 to 1885	-	-	0.60
	1930 to 1990	-	-	0.60
	2300 to 2496	-	-	0.82
	2496 to 2690	-	-	1.45
Return Loss@Low-Band (dB)	617 to 2690	10	13.4	-
Attenuation (dB)	3300 to 3700	22	27.4	-
	3700 to 3800	22	27.2	-
	3800 to 4200	22	26.6	-
	4400 to 5000	27	30.0	-
	5150 to 5925	30	34.7	-
	5925 to 12750	10	31.9	-
Characteristic Impedance (ohm)		50 (Nominal)		

Ta = +25+/-5°C

Middle-Band

Parameter	Frequency (MHz)	TDK Spec		
		Min.	Typ.	Max.
Insertion Loss (dB)	3300 to 3400	-	0.92	1.20
	3400 to 3600	-	0.84	1.10
	3600 to 3800	-	1.07	1.35
Insertion Loss (dB) (-40 to +90 °C)	3300 to 3400	-	-	1.35
	3400 to 3600	-	-	1.30
	3600 to 3800	-	-	1.65
Return Loss@Mid-Band (dB)	3300 to 3800	10	25	-
Attenuation (dB)	617 to 1427	22	23.7	-
	1427 to 2500	23	25.0	-
	2500 to 2690	19	23.9	-
	4400 to 5000	10	12.7	-
Characteristic Impedance (ohm)		50 (Nominal)		

Ta = +25+/-5°C

TPX255000MT-7066A1

■ ELECTRICAL CHARACTERISTICS

(Measurement)

High-Band

Parameter	Frequency (MHz)	TDK Spec		
		Min.	Typ.	Max.
Insertion Loss (dB)	4400 to 4800	-	0.98	1.40
	4800 to 5000	-	0.78	1.00
Insertion Loss (dB) (-40 to +90 °C)	4400 to 4800	-	-	1.61
	4800 to 5000	-	-	1.20
Return Loss@High-Band (dB)	4400 to 5000	10	16.7	-
Attenuation (dB)	617 to 2690	25	36.3	-
	2690 to 3150	5	15.6	-
	3300 to 3600	14	16.7	-
	3600 to 3800	13	15.9	-
	3800 to 4200	1	2.8	-
	8800 to 10000	15	17.9	-
	13200 to 15000	7	12.5	-
Characteristic Impedance (ohm)		50 (Nominal)		

 $T_a = +25\pm 5^\circ\text{C}$

Common

Parameter	Frequency (MHz)	TDK Spec			
		Min.	Typ.	Max.	
Isolation (dB)	LB - MB	617 to 960	22	23.7	-
		1695 to 1710	25	36.9	-
		1710 to 2200	23	26.7	-
		2300 to 2690	19	25.6	-
		3300 to 3800	22	28.4	-
		5150 to 5925	30	46.2	-
	LB - HB	617 to 960	25	43.2	-
		1427 to 1606	25	45.5	-
		1695 to 1710	25	57.3	-
		1710 to 2690	29	37.7	-
		3300 to 3800	22	45.3	-
		4400 to 5000	27.5	29.9	-
		5150 to 5925	30	33.6	-
	MB - HB	617 to 960	19	21.2	-
		1427 to 1606	25	29.8	-
		1710 to 2690	7.5	9.9	-
		3300 to 3600	14	16.8	-
		3600 to 3800	14	17.4	-
		4400 to 5000	11	13.4	-
	Characteristic Impedance (ohm)		50 (Nominal)		

 $T_a = +25\pm 5^\circ\text{C}$

TPX255000MT-7066A1

■ MAXIMUM RATINGS

Parameter		TDK Spec	Conditions
Operating temperature (°C)		-40 to +90 °C	
Storage temperature (°C)		-40 to +90 °C	
Power Handling (dBm) *1	Frequency (MHz)		
Low-Band	617 to 2690	36	CW
Middle-Band	3300 to 3800	33	CW
High-Band	4400 to 5000	33	CW
Human Body Model : HBM	@Each Port (V)	+/-1000	100pF / 1500ohm
Machine Model : MM	@Each Port (V)	+/-150	200pF / 0ohm
Charged Device Model : CDM	@Each Port (V)	+/-500	Humidity : 60%RH max

*1 : Refer to 3GPP TS 38.101-1 V15.2.0

TPX255000MT-7066A1

FREQUENCY CHARACTERISTICS

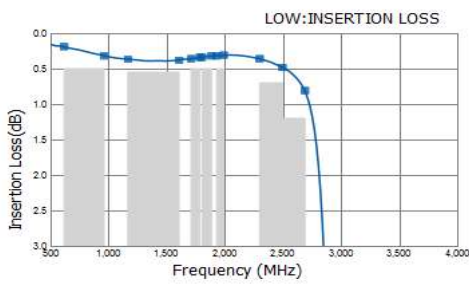

P/N	TPX255000MT-7066A1_v1.0N_May112018
617	0.19
960	0.32
1166	0.37
1606	0.38
1710	0.36
1785	0.34
1805	0.34
1885	0.32
1930	0.32
1990	0.31
2300	0.36
2496	0.48
2690	0.81

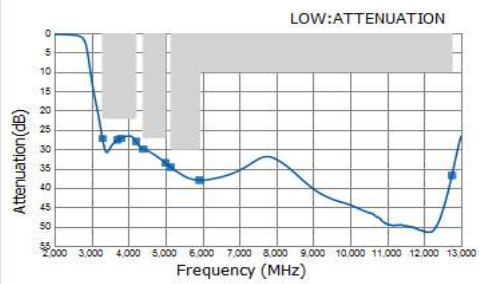

P/N	TPX255000MT-7066A1_v1.0N_May112018
3300	27.36
3700	27.61
3800	27.16
4200	27.98
4400	29.95
5000	33.53
5150	34.66
5925	38.03
12750	36.79

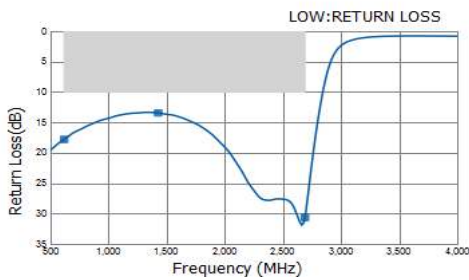

P/N	TPX255000MT-7066A1_v1.0N_May112018
617	17.81
1427	13.44
2690	30.66

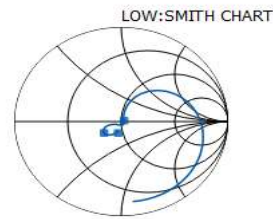

P/N	TPX255000MT-7066A1_v1.0N_May112018
617	44.49 / -10.93
1427	34.17 / -8.55
2690	52.53 / 1.62

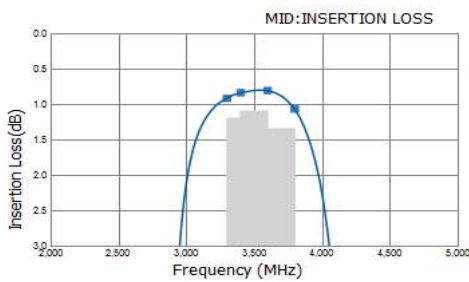

P/N	TPX255000MT-7066A1_v1.0N_May112018
3300	0.92
3400	0.84
3600	0.81
3800	1.07

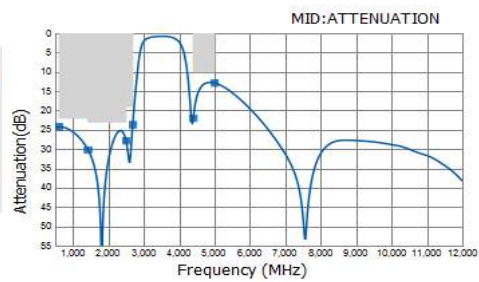

P/N	TPX255000MT-7066A1_v1.0N_May112018
617	24.23
1427	30.18
2500	27.83
2690	23.69
4400	21.98
5000	12.88

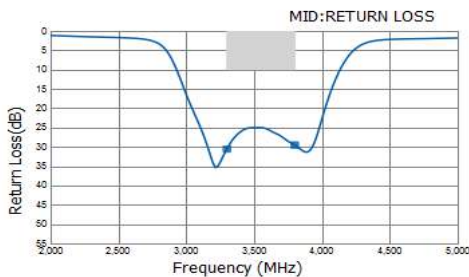

P/N	TPX255000MT-7066A1_v1.0N_May112018
3300	30.55
3800	29.55

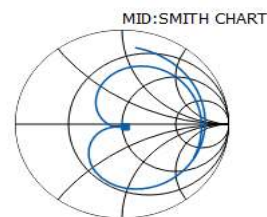

P/N	TPX255000MT-7066A1_v1.0N_May112018
3300	52.42 / -1.84
3800	52.55 / -2.27

TPX255000MT-7066A1

FREQUENCY CHARACTERISTICS

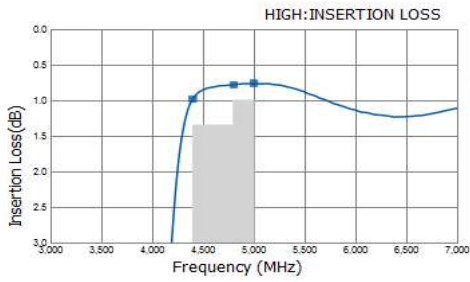

P/N	TPX255000MT-
Freq	7066A1_v1.0N_May112018
4400	0.98
4800	0.78
5000	0.76

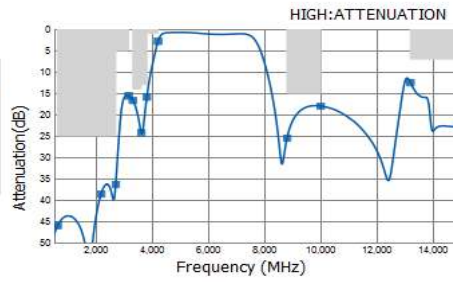

P/N	TPX255000MT-
Freq	7066A1_v1.0N_May112018
617	46.01
2170	38.60
2690	36.36
3150	15.62
3300	16.69
3600	24.21
3800	15.90
4200	2.84
8800	25.52
10000	18.02
13200	12.51
15000	22.33

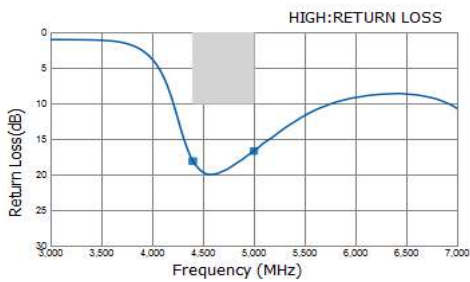

P/N	TPX255000MT-
Freq	7066A1_v1.0N_May112018
4400	18.12
5000	16.71

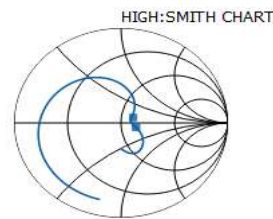

P/N	TPX255000MT-
Freq	7066A1_v1.0N_May112018
4400	61.14 / 8.21
5000	66.06 / -5.45

TPX255000MT-7066A1

FREQUENCY CHARACTERISTICS

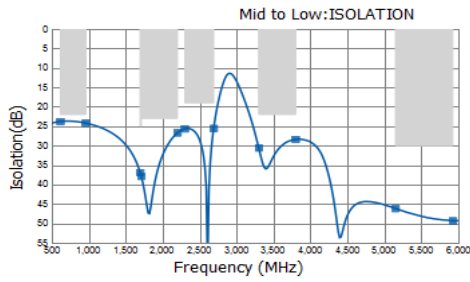

P/N	TPX255000MT-7066A1_v1.0N_May112018
Freq	
617	23.79
960	24.21
1695	36.90
1710	37.90
2200	26.71
2300	25.66
2690	25.59
3300	30.59
3800	28.38
5150	46.19
5925	49.36

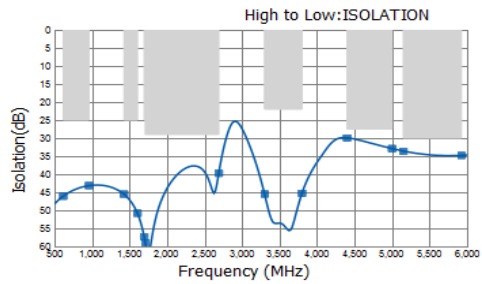

P/N	TPX255000MT-7066A1_v1.0N_May112018
Freq	
617	46.09
960	43.15
1427	45.52
1606	50.82
1695	57.33
1710	58.98
2690	39.72
3300	45.49
3800	45.26
4400	29.92
5000	32.90
5150	33.60
5925	34.79

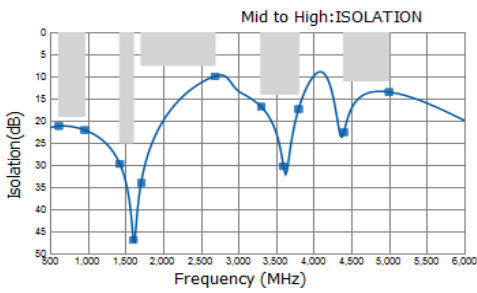

P/N	TPX255000MT-7066A1_v1.0N_May112018
Freq	
617	21.22
960	22.12
1427	29.75
1606	46.91
1710	34.04
2690	9.94
3300	16.81
3600	30.27
3800	17.38
4400	22.63
5000	13.52

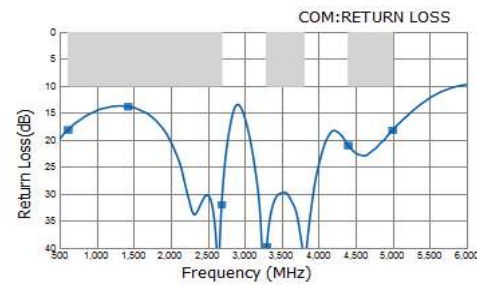

P/N	TPX255000MT-7066A1_v1.0N_May112018
Freq	
617	18.14
1427	13.84
2690	31.96
3300	39.73
3800	41.50
4400	21.03
5000	18.17

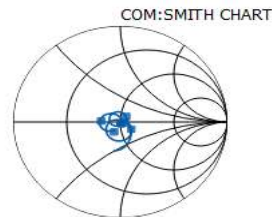

P/N	TPX255000MT-7066A1_v1.0N_May112018
Freq	
617	42.27 / -8.48
1427	33.13 / 1.07
2690	52.58 / 0.17
3300	50.05 / -1.03
3800	49.21 / -0.26
4400	54.62 / 8.1
5000	60.48 / -8.8

TPX255000MT-7066A1

RECOMMENDED LAND PATTERN

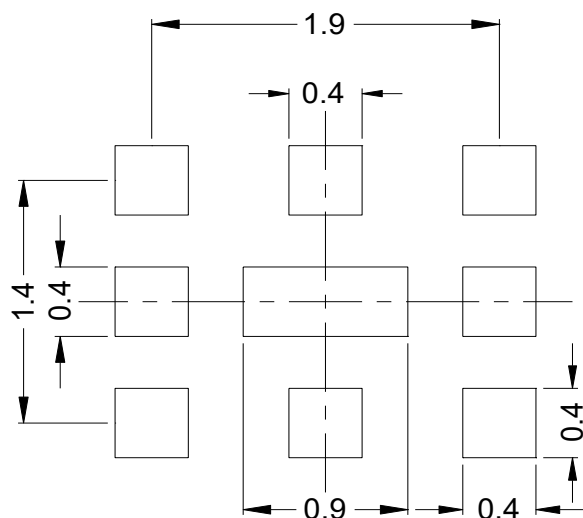

Unit : mm

EVALUATION BOARD

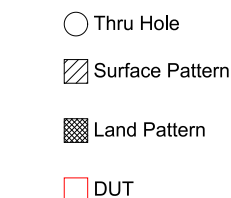
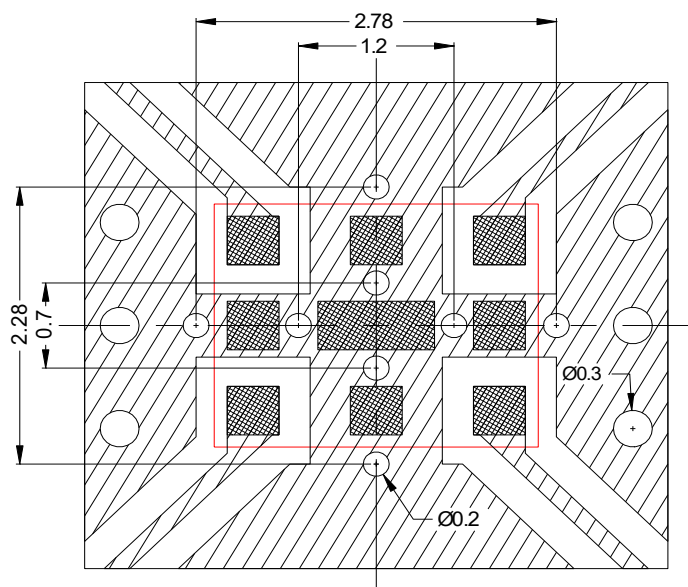

Material & Layer	Thickness
Copper Surface Pattern	0.035 mm
FR-4	0.10 mm
Inner GND	0.018 mm
FR-4	0.30 mm
Copper Bottom GND	0.035 mm

Unit : mm

- * Line width should be designed to match 50 ohm characteristic impedance depending on PCB material and thickness.
- ** The position of the thru hole which have possibility of influence to the performance are indicated by dimension line.

ENVIRONMENT INFORMATION

RoHS Statement
 RoHS Compliance

All specifications are subject to change without notice.
 Before using these products, be sure to request the delivery specifications.

TPX255000MT-7066A1

RECOMMENDED REFLOW PROFILE

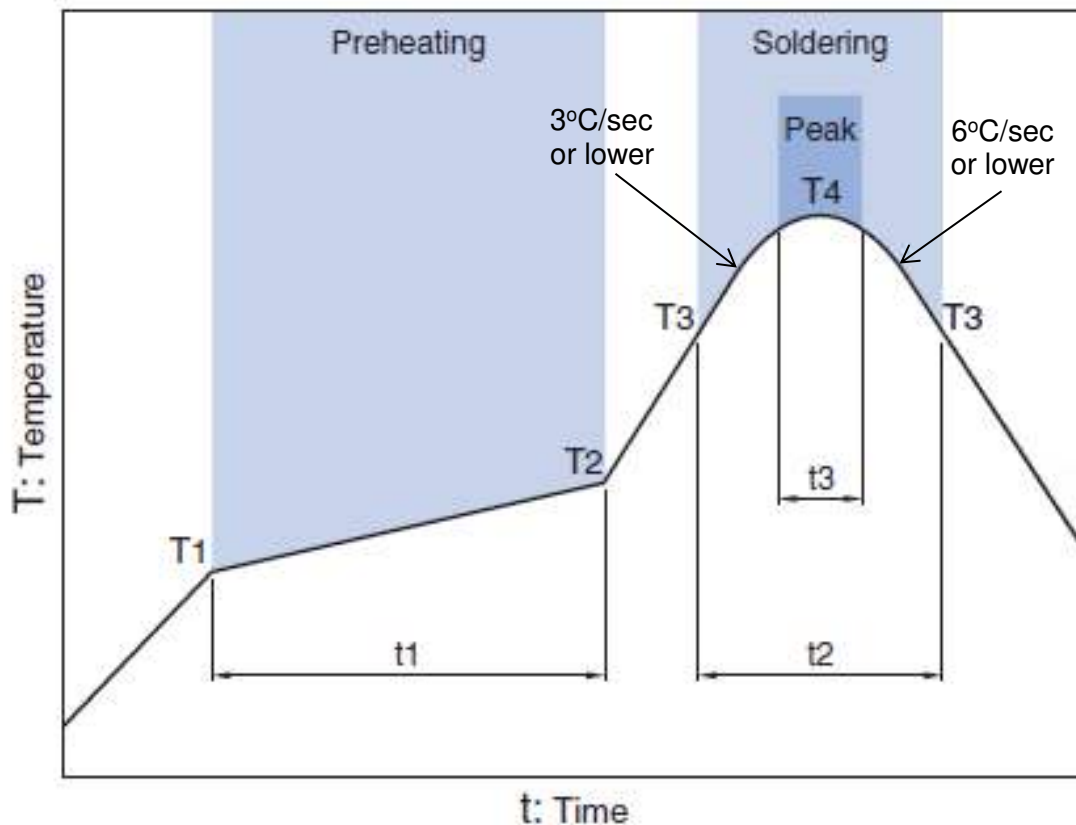

Preheating			Soldering			
			Critical zone (T3 to T4)		Peak	
Temp.	Temp.	Time	Temp.	Time	Temp.	Time
T1	T2	t1	T3	t2	T4	t3 *
150°C	200°C	60 to 120sec	217°C	60 to 120sec	240 to 260°C	30 sec Max

* t3 : Time within 5°C of actual peak temperature

The maximum number of reflow is 3.

Note: Lead free solder is recommended.
Recommended solder is Sn-3.0Ag-0.5Cu. (M705 by Senju Metal Industry)

GENERAL TECHNICAL INFORMATION

https://product.tdk.com/en/system/files?file=dam/doc/product/rf/rf/coupler/general_tech_info/rf_general-technical-info_02_en.pdf

TPX255000MT-7066A1**PACKAGING STYLE**

Reel Dimensions

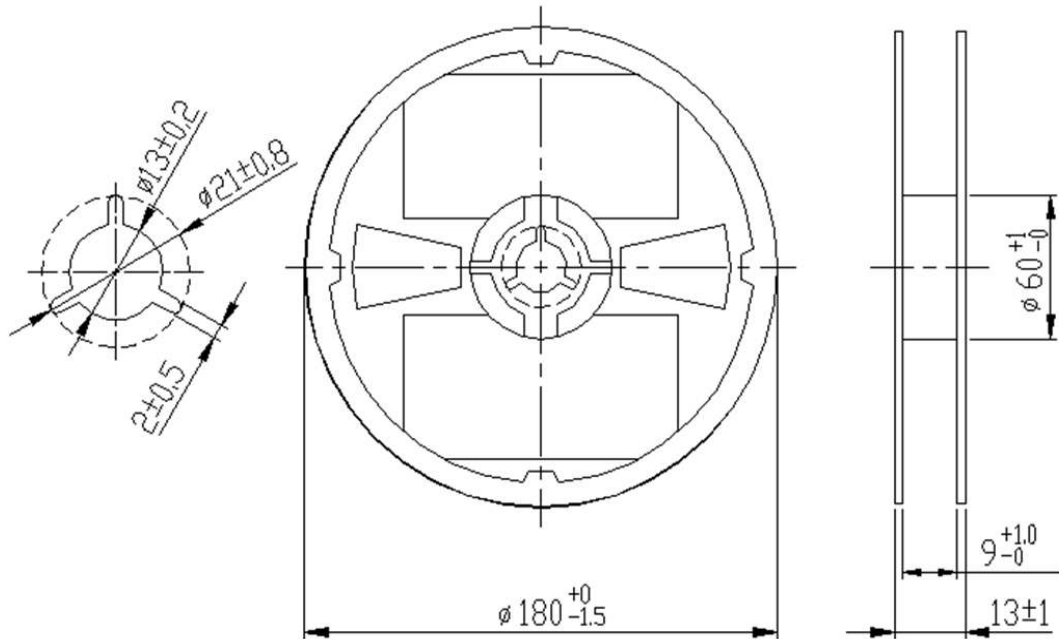

Dimensions in mm

Carrier Tape

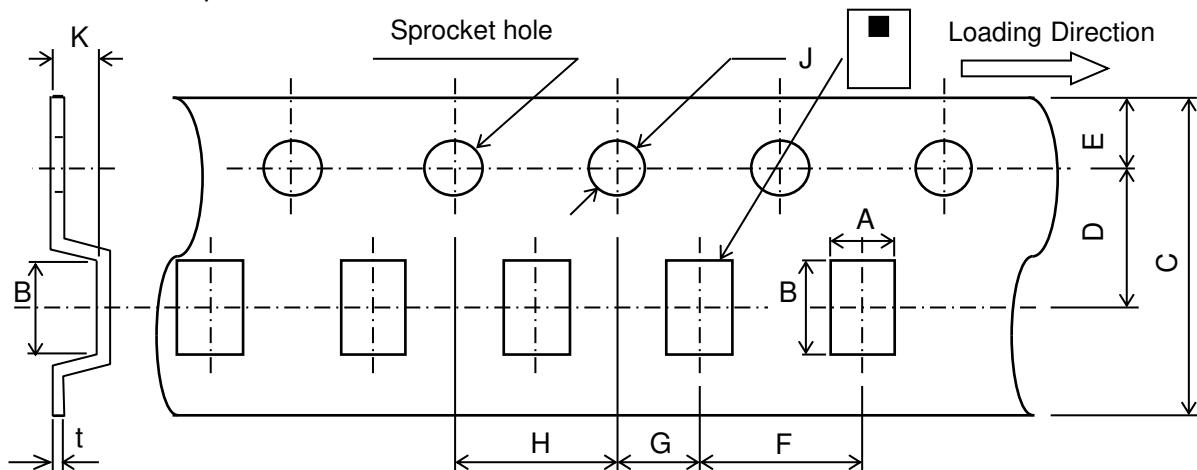

Dimensions (mm)

A	B	C	D	E	F	G	H	J	K	t
2.2	2.7	8.0	3.5	1.75	4.0	2.0	4.0	1.5	0.85	0.25
± 0.05	± 0.05	$+0.3/-0.1$	± 0.05	± 0.1	± 0.1	± 0.05	± 0.1	$+0.1/-0$	MAX	± 0.05

STANDARD PACKAGE QUANTITY**(pieces/reel)**

2,000

REMINDERS FOR USING THESE PRODUCTS

Before using these products, be sure to request the delivery specifications.

SAFETY REMINDERS

Please pay sufficient attention to the warnings for safe designing when using these products.

REMINDERS

The products listed on this catalog are intended for use in general electronic equipment (AV equipment, telecommunications equipment, home appliances, amusement equipment, computer equipment, personal equipment, office equipment, measurement equipment, industrial robots) under a normal operation and use condition.

The products are not designed or warranted to meet the requirements of the applications listed below, whose performance and/or quality require a more stringent level of safety or reliability, or whose failure, malfunction or trouble could cause serious damage to society, person or property.

Please understand that we are not responsible for any damage or liability caused by use of the products in any of the applications below or for any other use exceeding the range or conditions set forth in this catalog.

- | | |
|---|--|
| (1) Aerospace/Aviation equipment | (8) Public information-processing equipment |
| (2) Transportation equipment (cars, electric trains, ships, etc.) | (9) Military equipment |
| (3) Medical equipment | (10) Electric heating apparatus, burning equipment |
| (4) Power-generation control equipment | (11) Disaster prevention/crime prevention equipment |
| (5) Atomic energy-related equipment | (12) Safety equipment |
| (6) Seabed equipment | (13) Other applications that are not considered general-purpose applications |
| (7) Transportation control equipment | |

When using this product in general-purpose applications, you are kindly requested to take into consideration securing protection circuit/equipment or providing backup circuits, etc., to ensure higher safety.