

# KW DCLMS1.PC

## TOPLED® E3014

The TOPLED Compact 3014 has a wide beam angle with a compact format (3.0 mm x 1.4 mm) and is one of the smallest LED for screen backlighting. It is therefore ideal for injecting in light guides for homogeneous illumination applications where the TOPLED Compact 3014 never fails to impress with its performance on system level.



## Applications

- Electronic Equipment
- White Goods

## Features:

- Package: white SMT package, colored silicone resin
- Chip technology: InGaN on Sapphire
- Typ. Radiation: 120°
- Color: Cx = 0.35, Cy = 0.35 acc. to CIE 1931 (● white)
- Corrosion Robustness Class: 1B
- Color temperature: 4500K - 8000K
- CRI: 70 (min.)
- ESD: 2 kV acc. to ANSI/ESDA/JEDEC JS-001 (HBM, Class 2)

## Ordering Information

Type	Luminous Intensity <sup>1)</sup> $I_F = 20 \text{ mA}$ $I_v$	Color temperature	Ordering Code
KW DCLMS1.PC-BYCX-5J7K-1	2100 ... 3300 mcd	4500 K	Q65111A4105
KW DCLMS1.PC-BYCX-5H7I-1	2100 ... 3300 mcd	5000 K	Q65111A4104
KW DCLMS1.PC-BYCX-4A7D-1	2100 ... 3300 mcd	8000 K	Q65111A4103

## Maximum Ratings

Parameter	Symbol		Values
Operating Temperature	$T_{op}$	min. max.	-40 °C 85 °C
Storage Temperature	$T_{stg}$	min. max.	-40 °C 100 °C
Junction Temperature	$T_j$	max.	110 °C
Forward current $T_s = 25\text{ °C}$	$I_F$	max.	30 mA
Surge Current $t \leq 10000\text{ }\mu\text{s}$ ; $D = 0.1$ ; $T_s = 25\text{ °C}$	$I_{FS}$	max.	100 mA
ESD withstand voltage acc. to ANSI/ESDA/JEDEC JS-001 (HBM, Class 2)	$V_{ESD}$		2 kV
Reverse voltage <sup>2)</sup>	$V_R$		Not designed for reverse operation

## Characteristics

$I_F = 20 \text{ mA}$ ;  $T_S = 25 \text{ °C}$

Parameter	Symbol		Values
Chromaticity Coordinate <sup>3)</sup>	Cx	typ.	0.35
	Cy	typ.	0.35
Viewing angle at 50 % $I_V$	$2\phi$	typ.	110 °
Forward Voltage <sup>4)</sup> $I_F = 20 \text{ mA}$	$V_F$	min.	2.80 V
		typ.	3.05 V
		max.	3.40 V
Reverse current <sup>2)</sup>	$I_R$		Not designed for reverse operation
Color Rendering Index	CRI	min.	70
Real thermal resistance junction/solderpoint <sup>5)</sup>	$R_{thJS \text{ real}}$	typ.	130 K / W
		max.	160 K / W

## Brightness Groups

Group	Luminous Intensity <sup>1)</sup> $I_F = 20 \text{ mA}$ min. $I_v$	Luminous Intensity <sup>1)</sup> $I_F = 20 \text{ mA}$ max. $I_v$	Luminous Flux <sup>6)</sup> $I_F = 20 \text{ mA}$ typ. $\Phi_v$
BY	2100 mcd	2400 mcd	6750 mlm
BZ	2400 mcd	2800 mcd	7800 mlm
CX	2800 mcd	3300 mcd	9150 mlm

## Forward Voltage Groups

Group	Forward Voltage <sup>4)</sup> $I_F = 20 \text{ mA}$ min. $V_F$	Forward Voltage <sup>4)</sup> $I_F = 20 \text{ mA}$ max. $V_F$
24	2.80 V	3.00 V
64	3.00 V	3.20 V
A4	3.20 V	3.40 V

## Chromaticity Coordinate Groups

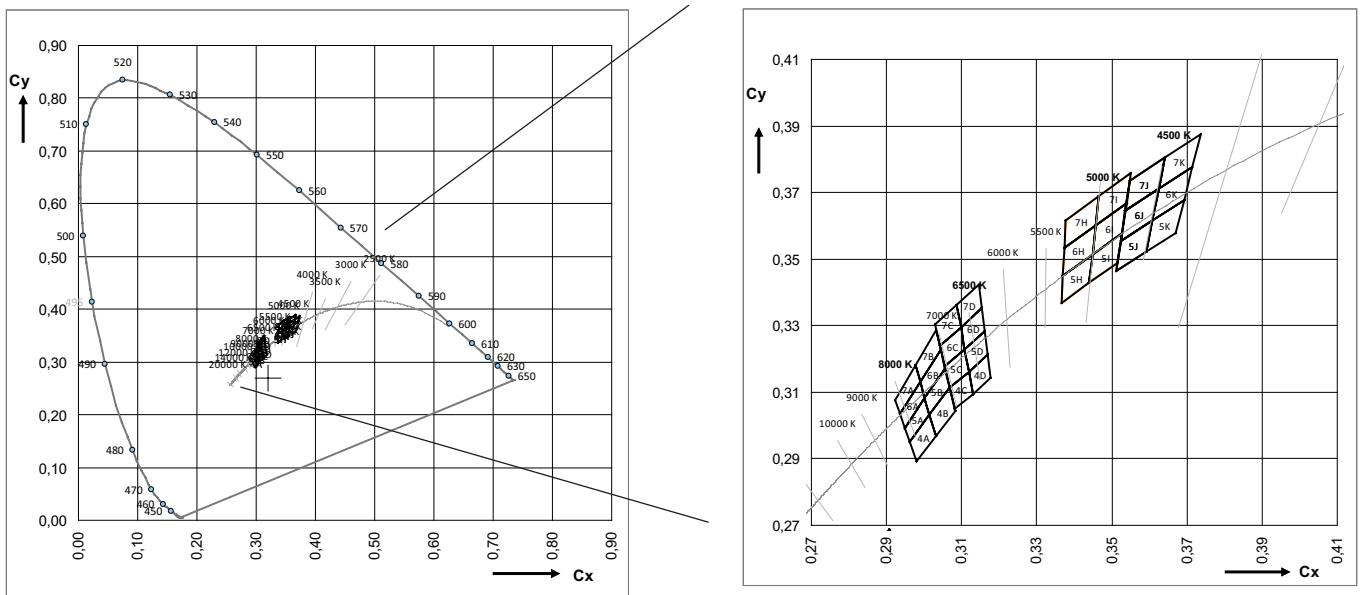

### Color Chromaticity Groups <sup>3)</sup>

Group	Cx	Cy	CCT	Group	Cx	Cy	CCT	Group	Cx	Cy	CCT
5J	0.3512	0.3465	4500	7J	0.3536	0.3646	4500	6H	0.3369	0.3451	5000
	0.3524	0.3555	4500		0.3548	0.3736	4500		0.3373	0.3534	5000
	0.3608	0.3616	4500		0.3642	0.3805	4500		0.3456	0.3601	5000
	0.3591	0.3522	4500		0.3625	0.3711	4500		0.3448	0.3515	5000
5K	0.3591	0.3522	4500	7K	0.3625	0.3711	4500	6I	0.3448	0.3515	5000
	0.3608	0.3616	4500		0.3642	0.3805	4500		0.3456	0.3601	5000
	0.3692	0.3677	4500		0.3736	0.3874	4500		0.3539	0.3669	5000
	0.3670	0.3578	4500		0.3714	0.3775	4500		0.3527	0.3578	5000
6J	0.3524	0.3555	4500	5H	0.3366	0.3369	5000	7H	0.3373	0.3534	5000
	0.3536	0.3646	4500		0.3369	0.3451	5000		0.3376	0.3616	5000
	0.3625	0.3711	4500		0.3448	0.3515	5000		0.3464	0.3688	5000
	0.3608	0.3616	4500		0.3441	0.3428	5000		0.3456	0.3601	5000
6K	0.3608	0.3616	4500	5I	0.3441	0.3428	5000	7I	0.3456	0.3601	5000
	0.3625	0.3711	4500		0.3448	0.3515	5000		0.3464	0.3688	5000
	0.3714	0.3775	4500		0.3527	0.3578	5000		0.3551	0.3760	5000
	0.3692	0.3677	4500		0.3515	0.3487	5000		0.3539	0.3669	5000

Not for new design

Group	Cx	Cy	CCT	Group	Cx	Cy	CCT	Group	Cx	Cy	CCT
4A	0.2981	0.2892	8000	5C	0.3068	0.3113	8000	7A	0.2936	0.3034	8000
	0.2961	0.2952	8000		0.3055	0.3177	8000		0.2924	0.3076	8000
	0.3015	0.3033	8000		0.3108	0.3229	8000		0.2978	0.3181	8000
	0.3032	0.2968	8000		0.3119	0.3162	8000		0.2990	0.3131	8000
4B	0.3032	0.2968	8000	5D	0.3119	0.3162	8000	7B	0.2990	0.3131	8000
	0.3015	0.3033	8000		0.3108	0.3229	8000		0.2978	0.3181	8000
	0.3068	0.3113	8000		0.3162	0.3282	8000		0.3032	0.3286	8000
	0.3083	0.3044	8000		0.3170	0.3212	8000		0.3044	0.3228	8000
4C	0.3081	0.3049	8000	6A	0.2949	0.2993	8000	7C	0.3041	0.3240	8000
	0.3068	0.3113	8000		0.2936	0.3034	8000		0.3028	0.3304	8000
	0.3119	0.3162	8000		0.2990	0.3131	8000		0.3087	0.3363	8000
	0.3130	0.3095	8000		0.3002	0.3082	8000		0.3098	0.3296	8000
4D	0.3130	0.3095	8000	6B	0.3002	0.3082	8000	7D	0.3098	0.3296	8000
	0.3119	0.3162	8000		0.2990	0.3131	8000		0.3087	0.3363	8000
	0.3170	0.3212	8000		0.3044	0.3228	8000		0.3146	0.3422	8000
	0.3178	0.3142	8000		0.3056	0.3171	8000		0.3154	0.3352	8000
5A	0.2961	0.2952	8000	6C	0.3055	0.3177	8000				
	0.2949	0.2993	8000		0.3041	0.3240	8000				
	0.3002	0.3082	8000		0.3098	0.3296	8000				
	0.3015	0.3033	8000		0.3108	0.3229	8000				
5B	0.3015	0.3033	8000	6D	0.3108	0.3229	8000				
	0.3002	0.3082	8000		0.3098	0.3296	8000				
	0.3056	0.3171	8000		0.3154	0.3352	8000				
	0.3068	0.3113	8000		0.3162	0.3282	8000				

---

## Group Name on Label

**Example: BY-4A-24**

Brightness	Color Chromaticity	Forward Voltage
BY	4A	24

---



### Relative Spectral Emission <sup>6)</sup>

$I_{rel} = f(\lambda); I_F = 20 \text{ mA}; T_S = 25 \text{ }^\circ\text{C}$

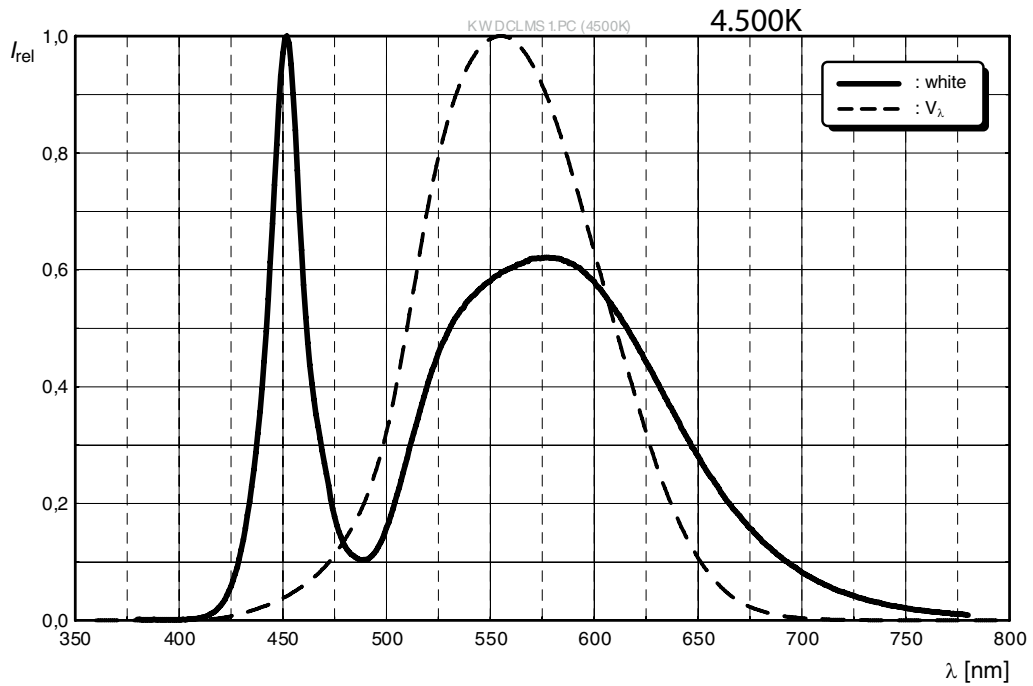

### Relative Spectral Emission <sup>6)</sup>

$I_{rel} = f(\lambda); I_F = 20 \text{ mA}; T_S = 25 \text{ }^\circ\text{C}$

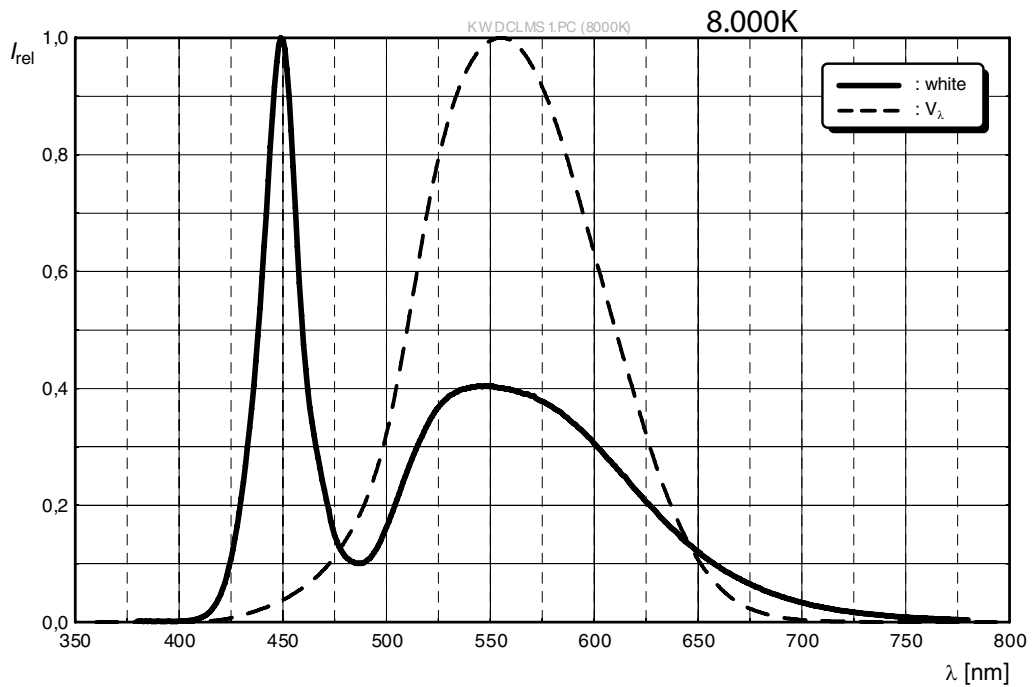

Not for new design

## Radiation Characteristics <sup>6)</sup>

$I_{rel} = f(\phi); T_S = 25\text{ °C}$

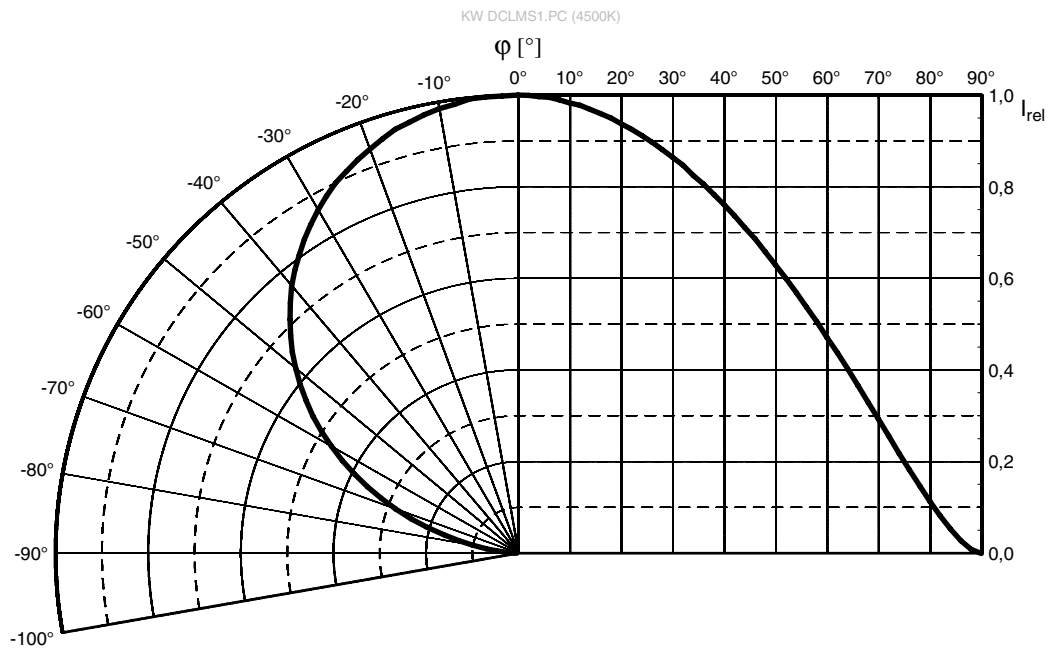

**Forward current** <sup>6), 7)</sup>

$I_F = f(V_F); T_S = 25\text{ °C}$

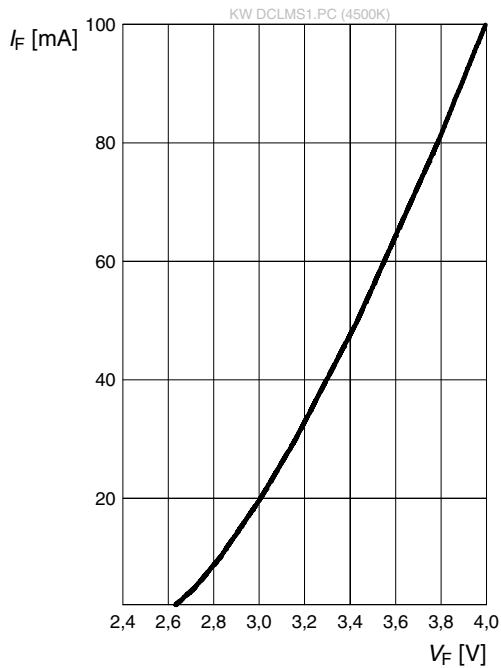

**Relative Luminous Intensity** <sup>6), 7)</sup>

$I_V/I_V(20\text{ mA}) = f(I_F); T_S = 25\text{ °C}$

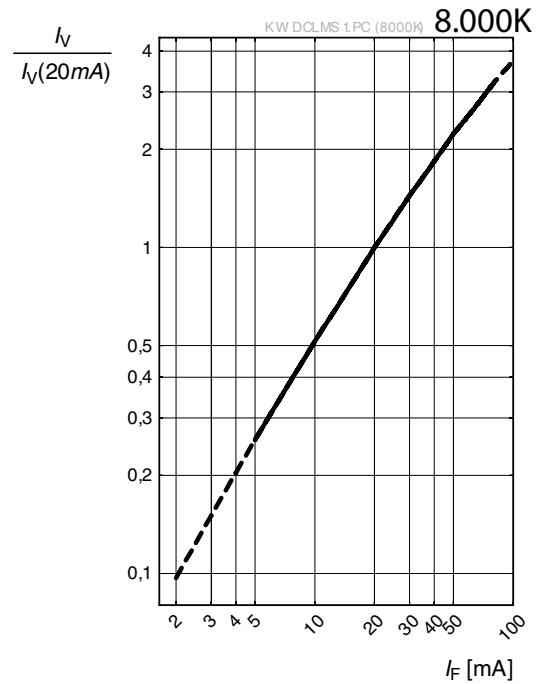

**Relative Luminous Intensity** <sup>6), 7)</sup>

$I_V/I_V(20\text{ mA}) = f(I_F); T_S = 25\text{ °C}$

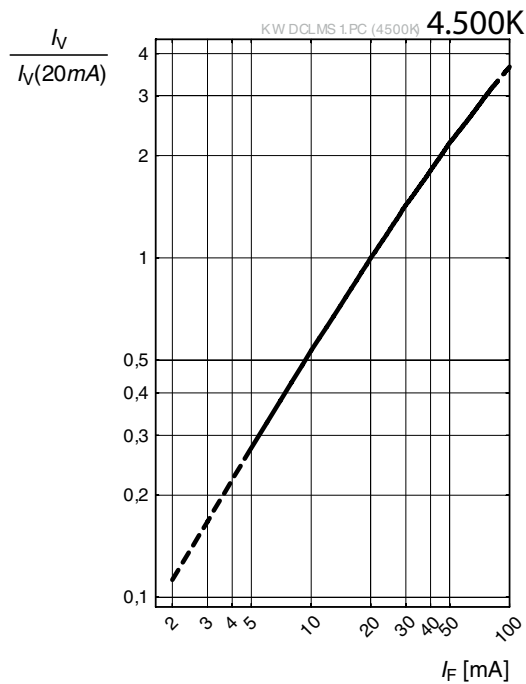

**Chromaticity Coordinate Shift** <sup>6)</sup>

$\Delta C_x, \Delta C_y = f(I_F); T_S = 25\text{ °C}$

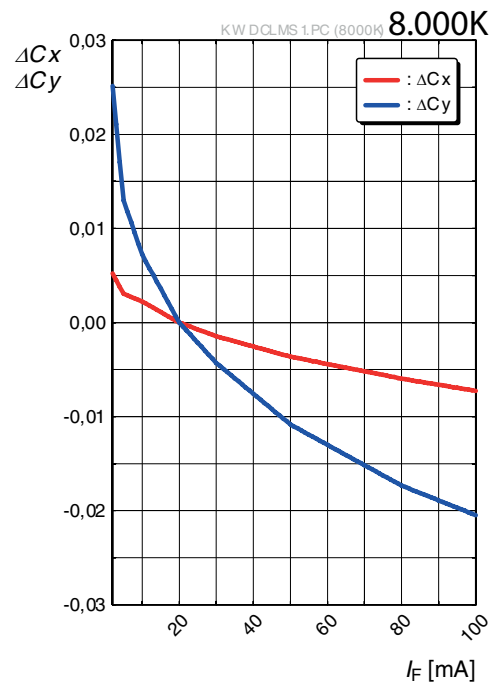

Not for new design

### Chromaticity Coordinate Shift <sup>6)</sup>

$$\Delta Cx, \Delta Cy = f(I_F); T_s = 25 \text{ °C}$$

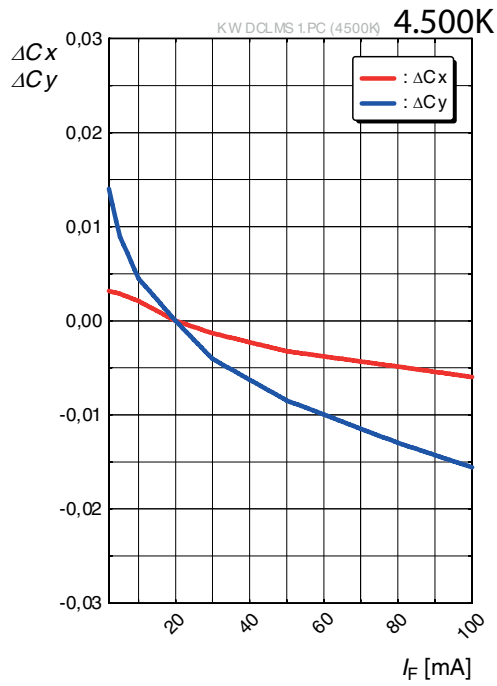

Not for new design

### Forward Voltage <sup>6)</sup>

$$\Delta V_F = V_F - V_F(25\text{ }^\circ\text{C}) = f(T_j); I_F = 20\text{ mA}$$

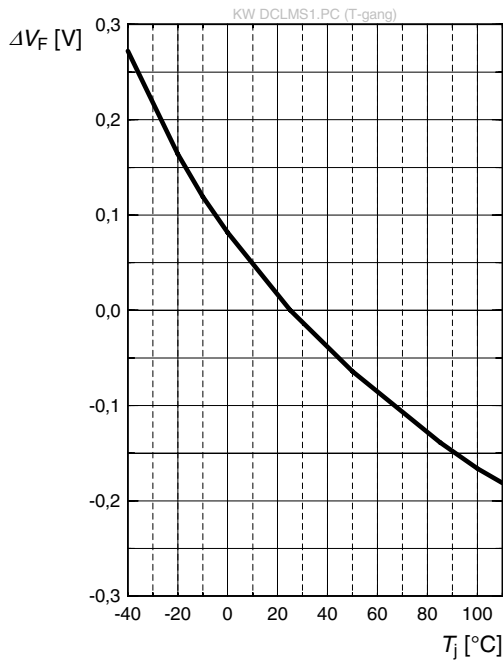

### Relative Luminous Intensity <sup>6)</sup>

$$I_V/I_V(25\text{ }^\circ\text{C}) = f(T_j); I_F = 20\text{ mA}$$

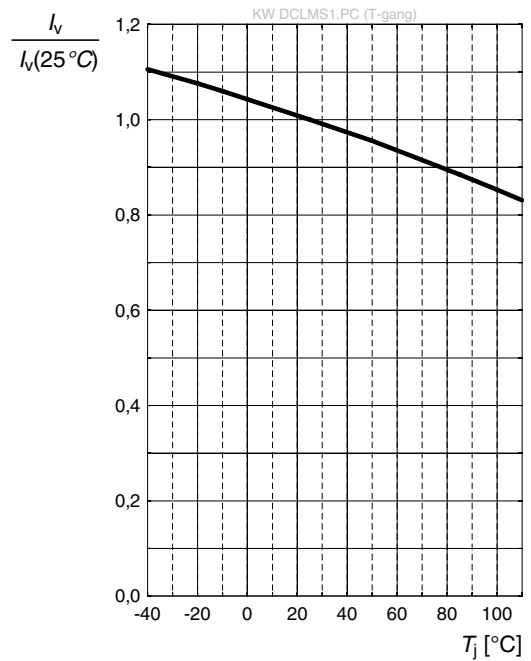

### Chromaticity Coordinate Shift <sup>6)</sup>

$$\Delta C_x, \Delta C_y = f(T_j); I_F = 20\text{ mA}$$

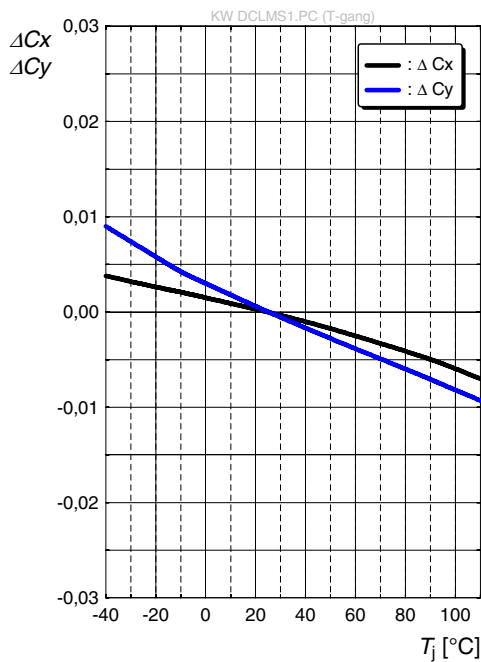

Not for new design

## Max. Permissible Forward Current

$$I_F = f(T)$$

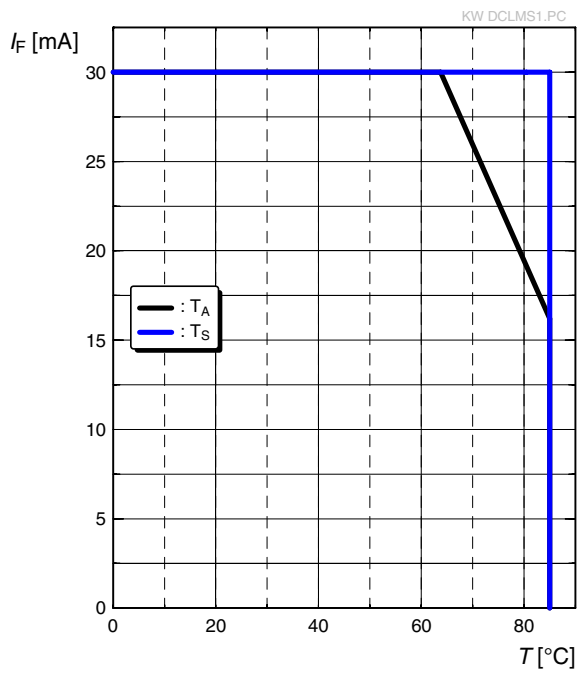

## Permissible Pulse Handling Capability

$$I_F = f(t_p); D: \text{Duty cycle}$$

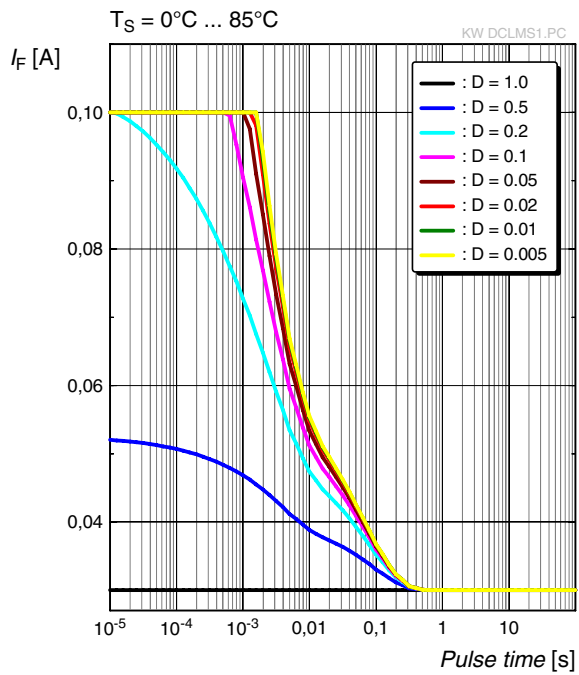

Not for new design

Dimensional Drawing <sup>8)</sup>

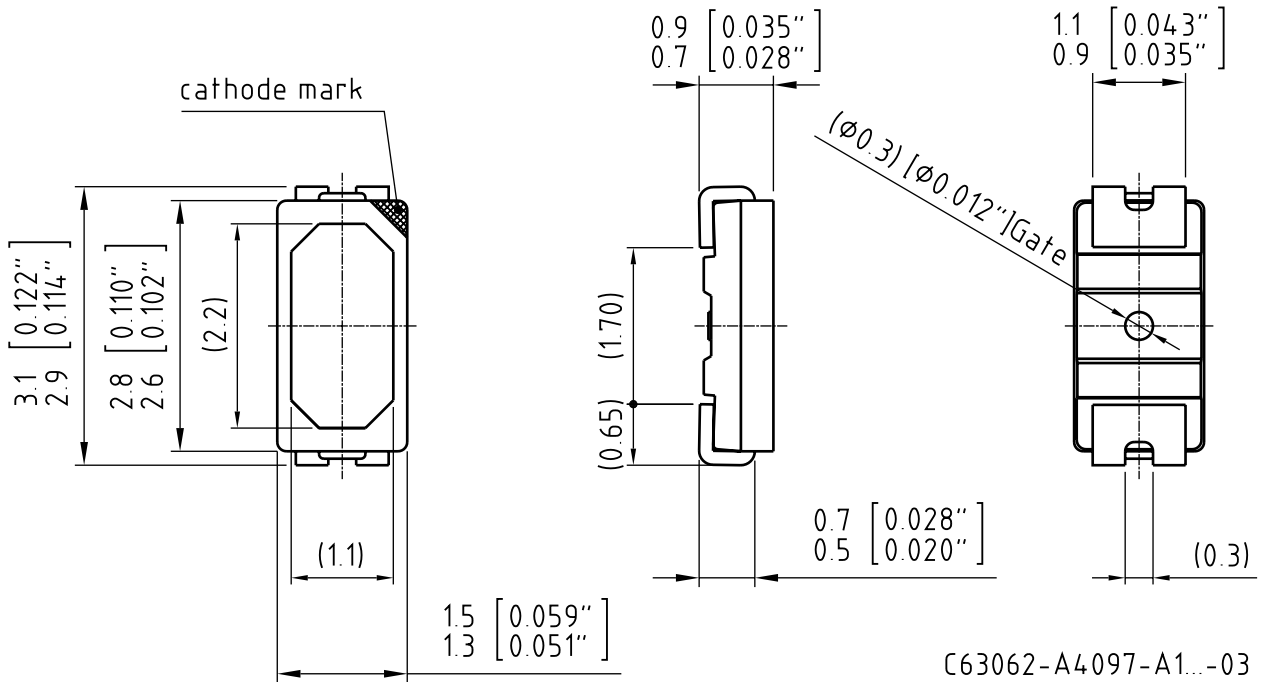

**Approximate Weight:** 10.0 mg

**Corrosion test:** Class: 1B  
 Test condition: 25°C / 75 % RH / 200ppb SO<sub>2</sub>, 200ppb NO<sub>2</sub>, 10ppb H<sub>2</sub>S, 10ppb Cl<sub>2</sub> / 21 days (EN 60068-2-60 (Method 4))

## Recommended Solder Pad <sup>8)</sup>

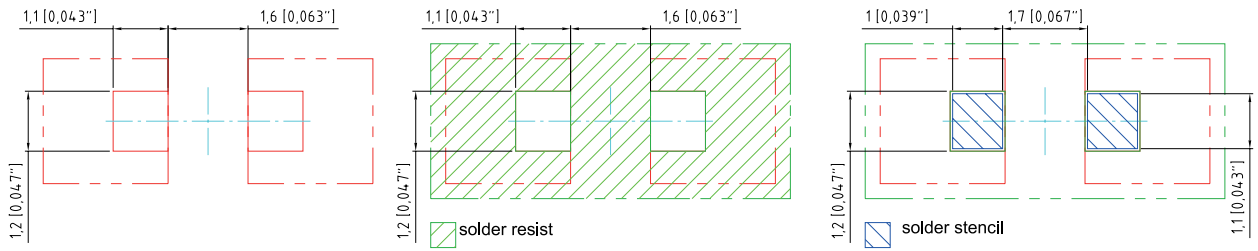

Component Location on Pad

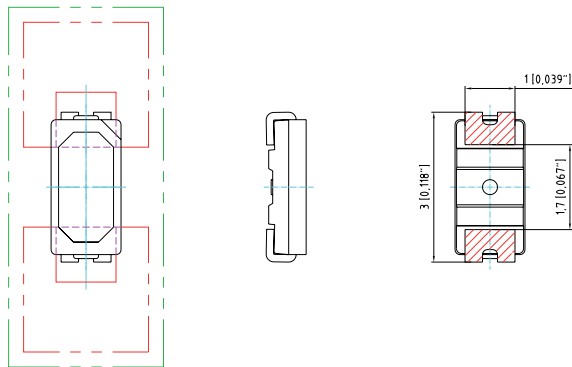

E062 3010 83-01

For superior solder joint connectivity results we recommend soldering under standard nitrogen atmosphere. Package not suitable for ultra sonic cleaning.



## Reflow Soldering Profile

Product complies to MSL Level 2 acc. to JEDEC J-STD-020E

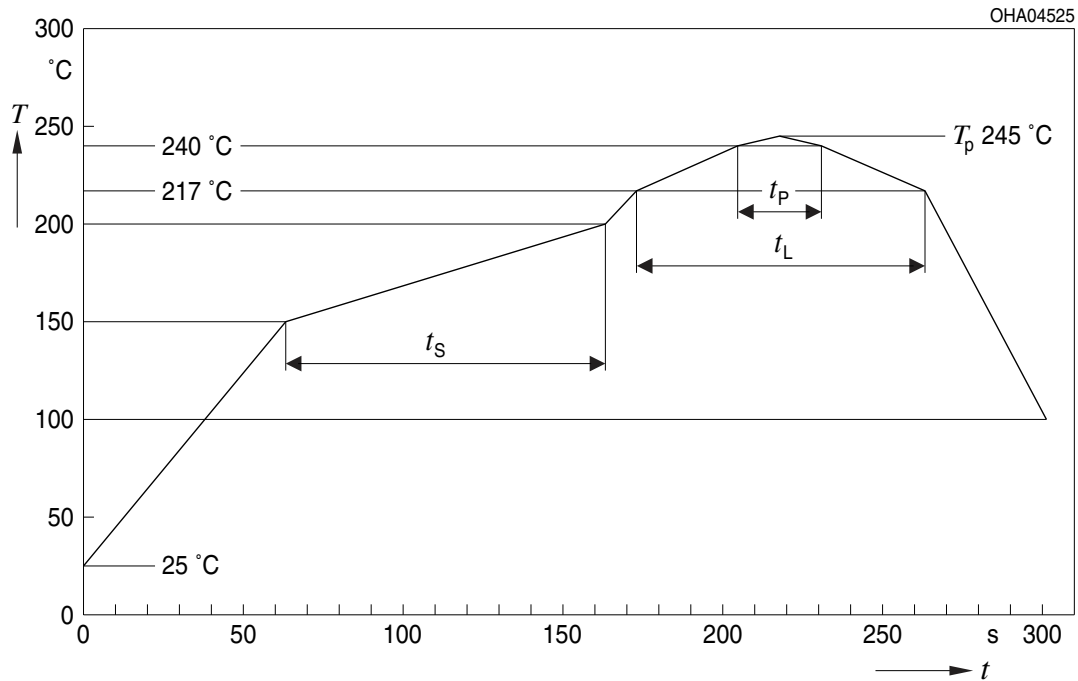

Profile Feature	Symbol	Pb-Free (SnAgCu) Assembly			Unit
		Minimum	Recommendation	Maximum	
Ramp-up rate to preheat <sup>*)</sup> 25 °C to 150 °C			2	3	K/s
Time $t_s$ $T_{Smin}$ to $T_{Smax}$	$t_s$	60	100	120	s
Ramp-up rate to peak <sup>*)</sup> $T_{Smax}$ to $T_p$			2	3	K/s
Liquidus temperature	$T_L$		217		°C
Time above liquidus temperature	$t_L$		80	100	s
Peak temperature	$T_p$		245	260	°C
Time within 5 °C of the specified peak temperature $T_p - 5$ K	$t_p$	10	20	30	s
Ramp-down rate* $T_p$ to 100 °C			3	6	K/s
Time 25 °C to $T_p$				480	s

All temperatures refer to the center of the package, measured on the top of the component  
 \*) slope calculation  $DT/Dt$ :  $Dt$  max. 5 s; fulfillment for the whole T-range

Not for new design

**Taping** <sup>8)</sup>

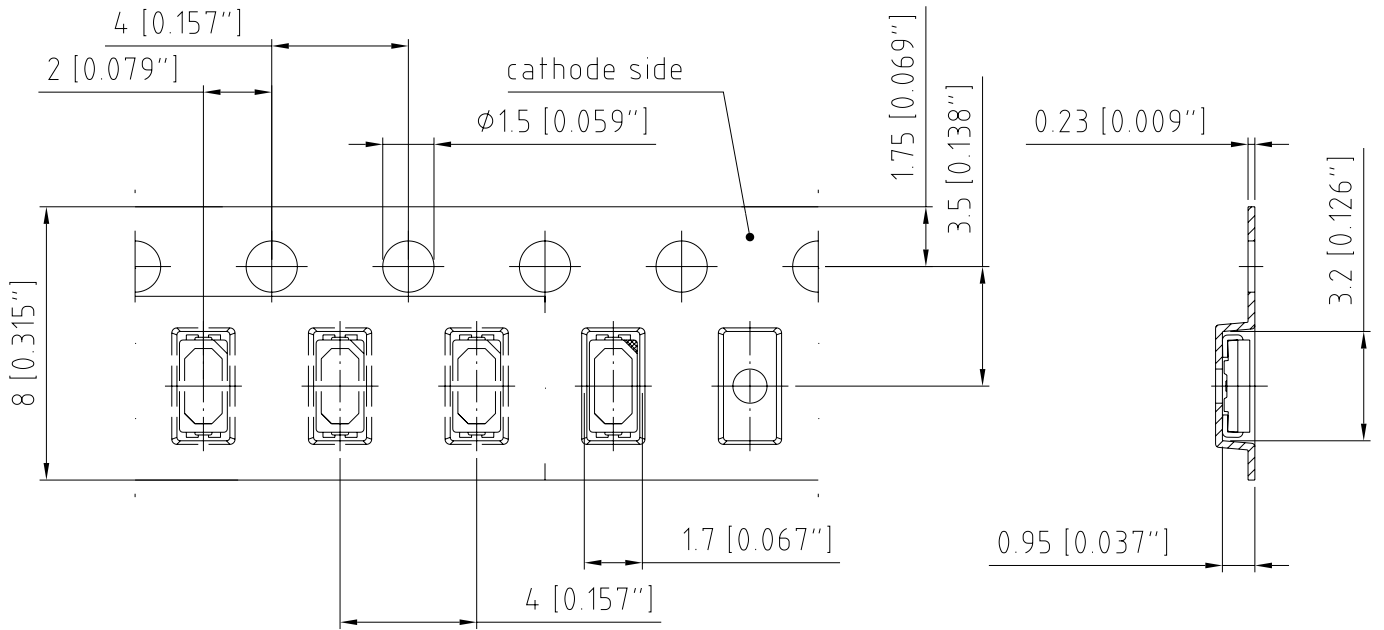

C63062-A4097-B1 -02

Not for new design

**Tape and Reel** <sup>9)</sup>

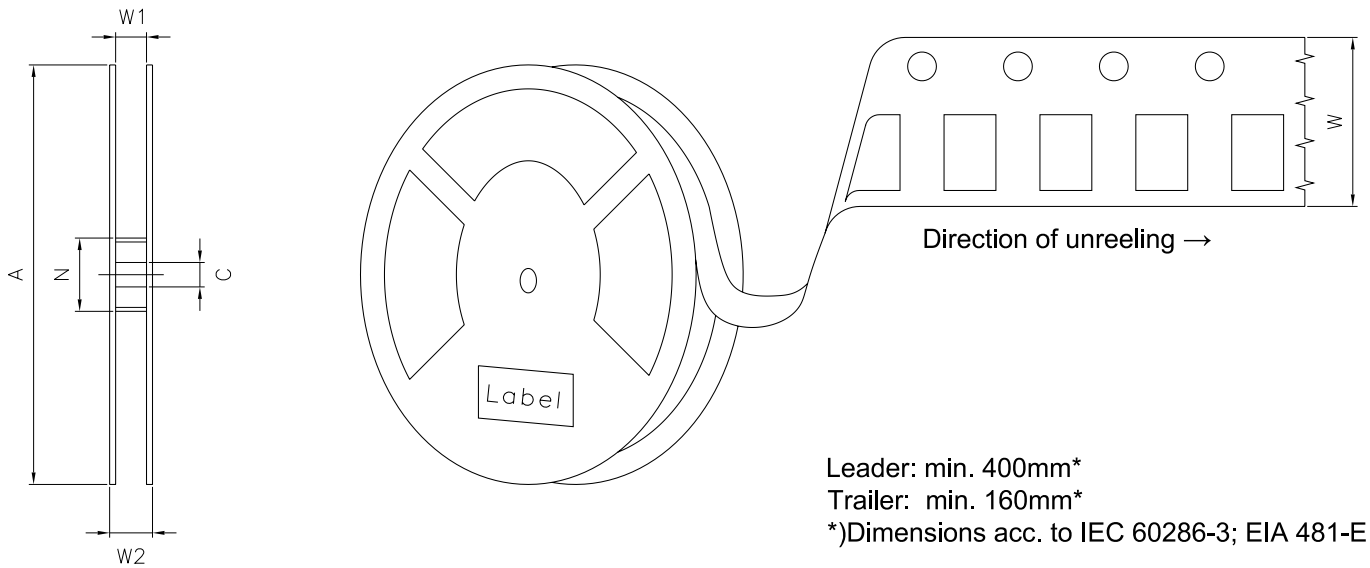

**Reel dimensions [mm]**

A	W	N <sub>min</sub>	W <sub>1</sub>	W <sub>2 max</sub>	Pieces per PU
180 mm	8 + 0.3 / - 0.1	60	8.4 + 2	14.4	2000

Not for new design

### Barcode-Product-Label (BPL)

**OSRAM Opto Semiconductors** LX XXXX BIN1: XX-XX-X-XXX-X

RoHS Compliant

(6P) BATCH NO: 1234567890

(1T) LOT NO: 1234567890 (9D) D/C: 1234

(X) PROD NO: 123456789(Q)QTY: 9999 (G) GROUP: XX-XX-X-X

ML Temp ST  
X XXX °C X

Pack: RXX  
DEMY XXX  
X\_X123\_1234.1234 X



The diagram shows a rectangular label with rounded corners. It contains the OSRAM logo and product name at the top left. To the right are fields for 'LX XXXX' and 'BIN1: XX-XX-X-XXX-X'. Below the logo is a 'RoHS Compliant' statement. The label features three horizontal barcode sections. The first is labeled '(6P) BATCH NO: 1234567890'. The second is labeled '(1T) LOT NO: 1234567890' and '(9D) D/C: 1234'. The third is labeled '(X) PROD NO: 123456789(Q)QTY: 9999' and '(G) GROUP: XX-XX-X-X'. To the right of the second barcode is a 'Moisture Sensitive Device' symbol (a circle with a diagonal line and three droplets) and 'ML Temp ST X XXX °C X'. Below that is a QR code and 'Pack: RXX', 'DEMY XXX', and 'X\_X123\_1234.1234 X'.

OHA04563

### Dry Packing Process and Materials <sup>8)</sup>

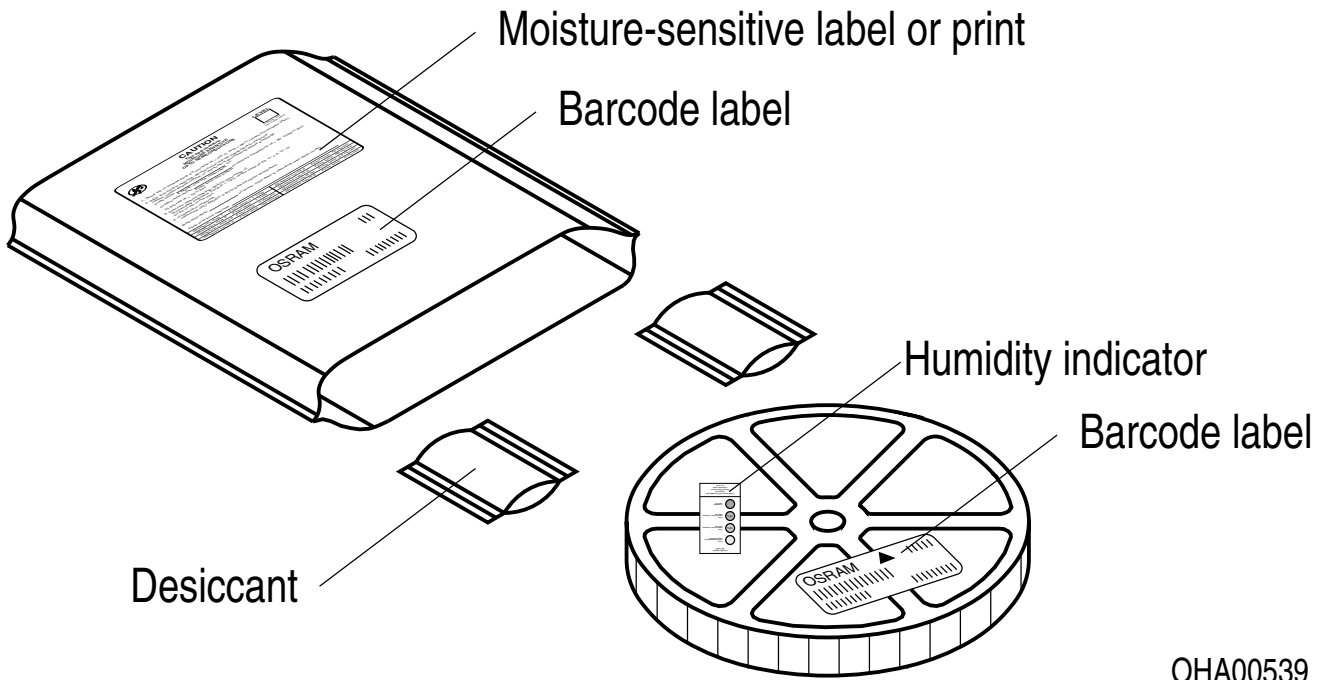

OHA00539

Moisture-sensitive product is packed in a dry bag containing desiccant and a humidity card according JEDEC-STD-033.

Not for new design

## Transportation Packing and Materials <sup>8)</sup>

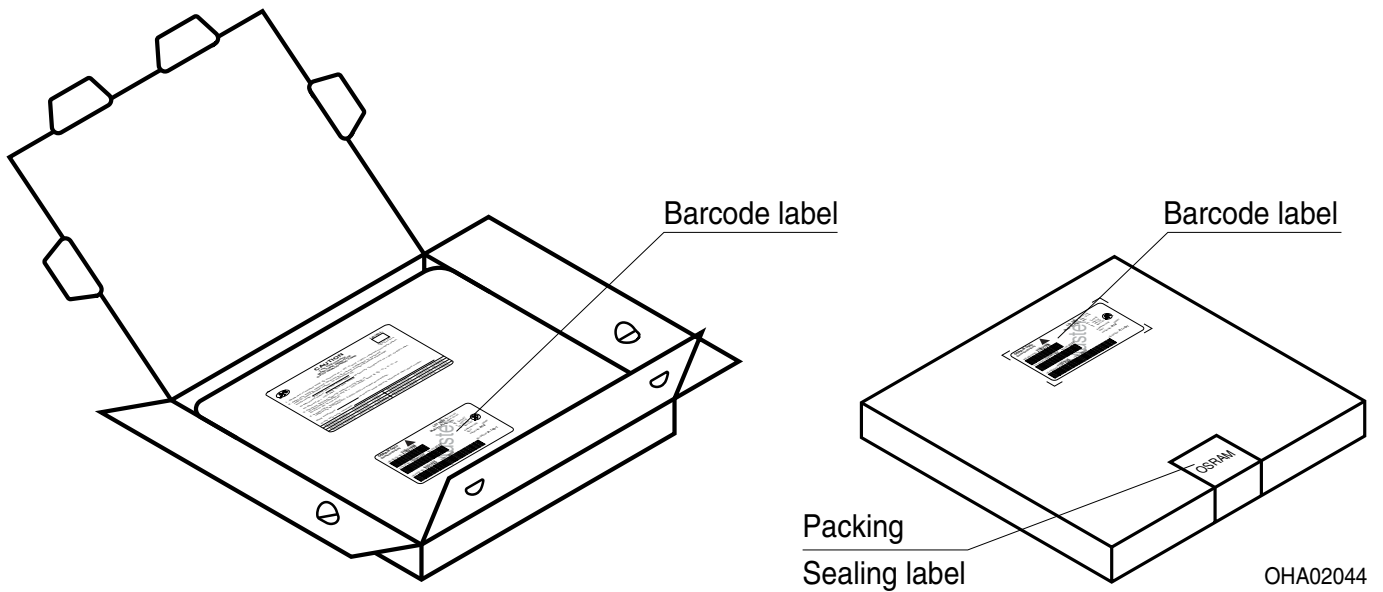

### Dimensions of transportation box in mm

Width	Length	Height
200 ± 5 mm	195 ± 5 mm	30 ± 5 mm

## Type Designation System

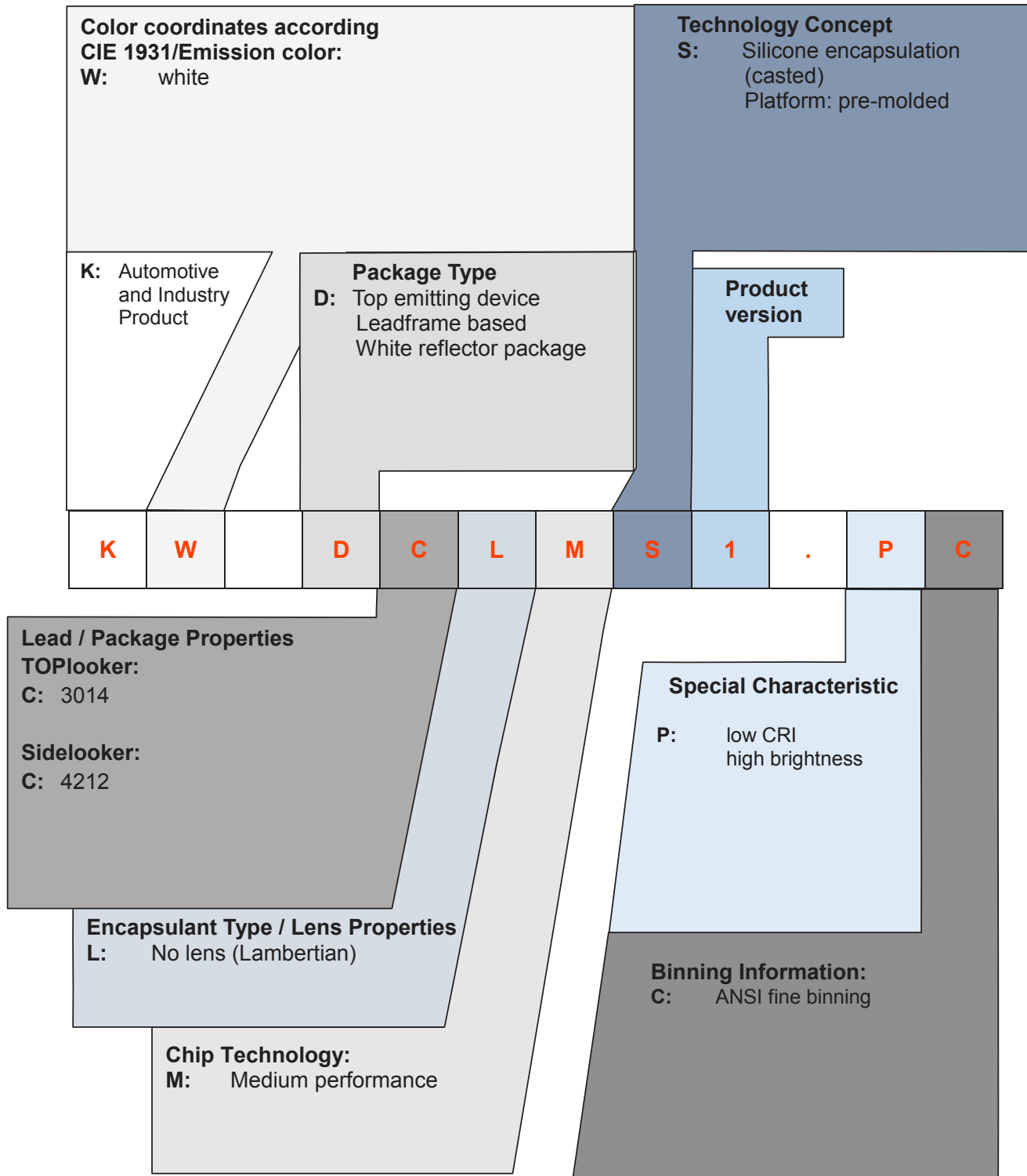

Not for new design

## Notes

The evaluation of eye safety occurs according to the standard IEC 62471:2006 (photo biological safety of lamps and lamp systems). Within the risk grouping system of this IEC standard, the device specified in this data sheet falls into the class **exempt group (exposure time 10000 s)**. Under real circumstances (for exposure time, conditions of the eye pupils, observation distance), it is assumed that no endangerment to the eye exists from these devices. As a matter of principle, however, it should be mentioned that intense light sources have a high secondary exposure potential due to their blinding effect. When looking at bright light sources (e.g. headlights), temporary reduction in visual acuity and afterimages can occur, leading to irritation, annoyance, visual impairment, and even accidents, depending on the situation.

Subcomponents of this device contain, in addition to other substances, metal filled materials including silver. Metal filled materials can be affected by environments that contain traces of aggressive substances. Therefore, we recommend that customers minimize device exposure to aggressive substances during storage, production, and use. Devices that showed visible discoloration when tested using the described tests above did show no performance deviations within failure limits during the stated test duration. Respective failure limits are described in the IEC60810.

For further application related informations please visit [www.osram-os.com/appnotes](http://www.osram-os.com/appnotes)

## Disclaimer

### Disclaimer

Language english will prevail in case of any discrepancies or deviations between the two language wordings.

### Attention please!

The information describes the type of component and shall not be considered as assured characteristics. Terms of delivery and rights to change design reserved. Due to technical requirements components may contain dangerous substances.

For information on the types in question please contact our Sales Organization.

If printed or downloaded, please find the latest version on the OSRAM OS website.

### Packing

Please use the recycling operators known to you. We can also help you – get in touch with your nearest sales office.

By agreement we will take packing material back, if it is sorted. You must bear the costs of transport. For packing material that is returned to us unsorted or which we are not obliged to accept, we shall have to invoice you for any costs incurred.

### Product safety devices/applications or medical devices/applications

OSRAM OS components are not developed, constructed or tested for the application as safety relevant component or for the application in medical devices.

In case Buyer – or Customer supplied by Buyer– considers using OSRAM OS components in product safety devices/applications or medical devices/applications, Buyer and/or Customer has to inform the local sales partner of OSRAM OS immediately and OSRAM OS and Buyer and /or Customer will analyze and coordinate the customer-specific request between OSRAM OS and Buyer and/or Customer.



---

## Glossary

- 1) **Brightness:** Brightness groups are tested at a current pulse duration of 25 ms and a tolerance of  $\pm 11\%$ .
- 2) **Reverse Operation:** Not designed for reverse operation. Continuous reverse operation can cause migration and damage of the device.
- 3) **Chromaticity coordinate groups:** Chromaticity coordinate groups are tested at a current pulse duration of 25 ms and a tolerance of  $\pm 0.01$ .
- 4) **Forward Voltage:** Forward voltages are tested at a current pulse duration of 1 ms and a tolerance of  $\pm 0.1$  V.
- 5) **Thermal Resistance:**  $R_{th\ max}$  is based on statistic values ( $6\sigma$ ).
- 6) **Typical Values:** Due to the special conditions of the manufacturing processes of semiconductor devices, the typical data or calculated correlations of technical parameters can only reflect statistical figures. These do not necessarily correspond to the actual parameters of each single product, which could differ from the typical data and calculated correlations or the typical characteristic line. If requested, e.g. because of technical improvements, these typ. data will be changed without any further notice.
- 7) **Characteristic curve:** In the range where the line of the graph is broken, you must expect higher differences between single devices within one packing unit.
- 8) **Tolerance of Measure:** Unless otherwise noted in drawing, tolerances are specified with  $\pm 0.1$  and dimensions are specified in mm.
- 9) **Tape and Reel:** All dimensions and tolerances are specified acc. IEC 60286-3 and specified in mm.

**Published by OSRAM Opto Semiconductors GmbH** EU RoHS and China RoHS compliant product  
**Leibnizstraße 4, D-93055 Regensburg**  
**www.osram-os.com © All Rights Reserved.**



此产品符合欧盟 RoHS 指令的要求；  
按照中国的相关法规和标准，不含有毒有害物质或元素。