

REVISIONS

P	LTR	DESCRIPTION	DATE	DWN	APVD
P		CUTTING BURR DETAILS ADDED	20NOV2018	RK	PS

- MATERIALS:  
HOUSING: POLYAMIDE 6, UL94V-2.  
COLOR: NATURAL.  
TUBULAR CONTACT: BRASS, TIN PLATED.  
SCREW: M3, STEEL, ZINC PLATED W/ NON-HEXAVALENT CHROMATE (CHROME III).
- MECHANICAL:  
PITCH: 8.0mm  
WIRE STRIP LENGTH: 5mm  
MIN. WIRE PULL OUT: 75 LBS.  
RECOMMENDED TIGHTENING TORQUE: 5 IN-LB.
- ELECTRICAL PROPERTIES:  
MAXIMUM CURRENT: 30A  
OPERATING VOLTAGE: 250V  
WIRE RANGE: 12-24 AWG  
DIELECTRIC WITHSTAND: 3000V
- ENVIRONMENTAL PROPERTIES:  
CONTINUOUS WORKING TEMP: -35°C TO +100°C
- CUTTING PROJECTION CAN BE ON BOTH SIDES DEPENDING ON CUTTING LOCATION.
- CUTTING BURR MAX. 1mm ALLOWED.

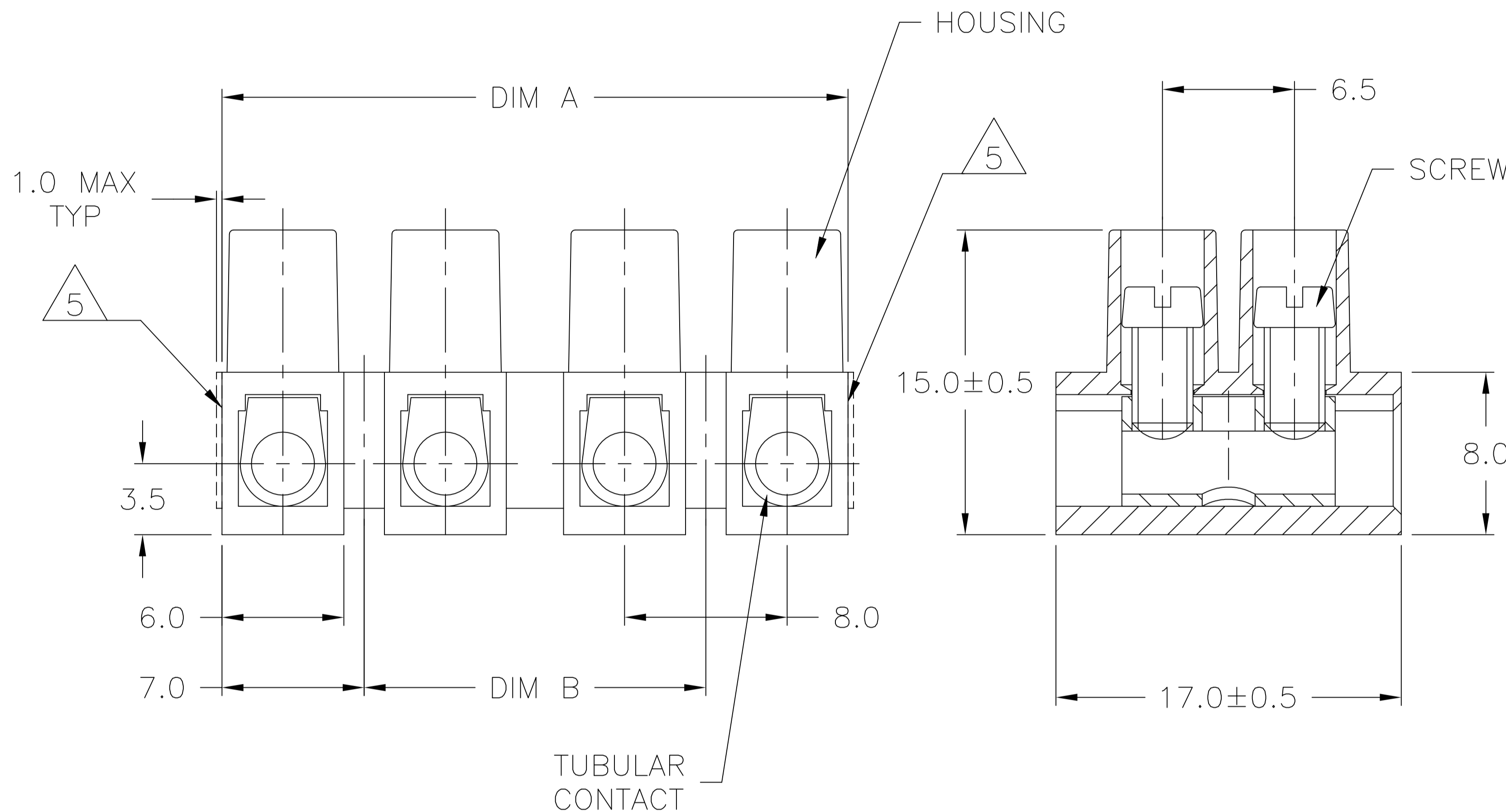

1776294-4 AS SHOWN

	80.0	94.0±1.0	12	TSB230 12	1-1776294-2
OBSOLETE	72.0	86.0±0.7	11	TSB230 11	-
	64.0	78.0±0.7	10	TSB230 10	1-1776294-0
	56.0	70.0±0.7	9	TSB230 09	1776294-9
	48.0	62.0±0.7	8	TSB230 08	1776294-8
OBSOLETE	40.0	54.0±0.7	7	TSB230 07	-
	32.0	46.0±0.7	6	TSB230 06	1776294-6
	24.0	38.0±0.5	5	TSB230 05	1776294-5
	16.0	30.0±0.5	4	TSB230 04	1776294-4
	8.0	22.0±0.5	3	TSB230 03	1776294-3
	-	14.0±0.5	2	TSB230 02	1776294-2
	-	6.0±0.3	1	TSB230 01	1776294-1
	DIM B	DIM A	NO. OF POS.	CATALOG NUMBER	TE PART NUMBER

THIS DRAWING IS A CONTROLLED DOCUMENT.		DWN S SCHLEGEL 3/18/05	<b>TE Connectivity Ltd.</b>		
DIMENSIONS: mm		CHK C RICHARD 3/18/05			
TOLERANCES UNLESS OTHERWISE SPECIFIED:		APVD C RICHARD 3/18/05	NAME 8.0mm PITCH, 30A, W/ TUNNEL CONNECTION EUROPA TERMINAL BLOCK		
 0 PLC ± - 1 PLC ± 0.3 2 PLC ± 0.25 3 PLC ± - 4 PLC ± - ANGLES ± -		PRODUCT SPEC -	APPLICATION SPEC -		
MATERIAL SEE NOTES	FINISH SEE NOTES	WEIGHT -	SIZE A3	CAGE CODE 00779	DRAWING NO C=1776294
CUSTOMER DRAWING			SCALE NTS	SHEET 1 of 1	REV P