

REVISIONS					
REV	DATE	DESCRIPTION	BY	CHK	APP'D
J2	21JUL2022	REVISED PER ECR-21-118222	JP	VS	

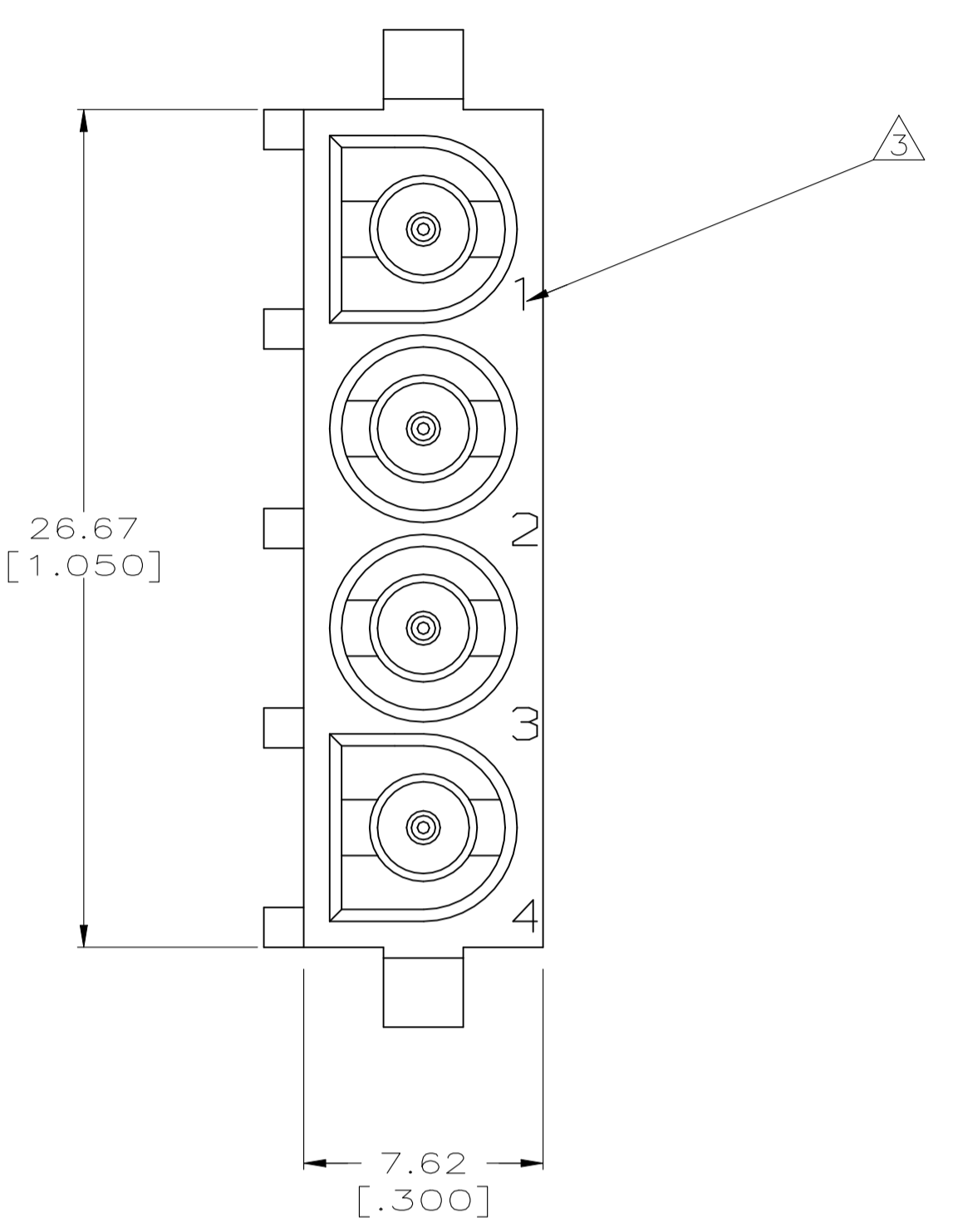

- PARTS COMPLY TO AMP SOLDERABILITY SPECIFICATION 109-11-3.
- CONTACT IS PLATED OVERALL WITH 0.00127 [.000050] NICKEL, THEN 0.00076 [.000030] GOLD OVER CONTACT LENGTH INDICATED AND MATTE TIN LEAD ON SOLDER TAIL END.
- CIRCUIT IDENTIFICATION CHARACTERS ARE ADJACENT TO THE INDICATED CAVITIES, BUT LOCATION AND ORIENTATION MAY DIFFER FROM PRINT.
- DIMENSIONS IN BRACKETS ARE IN INCHES.
- DRAIN HOLES LOCATED AS SHOWN. OPTIONAL CONSTRUCTION- ALL DRAIN HOLES LOCATED 90° AS SHOWN IN DETAIL A.
- CONTACT IS PLATED OVERALL WITH 0.00127 [.000050] NICKEL, THEN 0.00076 [.000030] GOLD OVER CONTACT LENGTH INDICATED AND MATTE TIN ON SOLDER TAIL END.
- OBsolete PARTS: OBSOLETE CIS STREAMLINING PER D.RENAUD/D.SINISI
- DIMENSIONS SHOWN REPRESENT PRODUCT IN DRY CONDITION. ADDITIONAL 2% GROWTH DUE TO END USE LOCATION MOISTURE ABSORPTION MAY OCCUR AND SHOULD BE ACCOUNTED FOR.

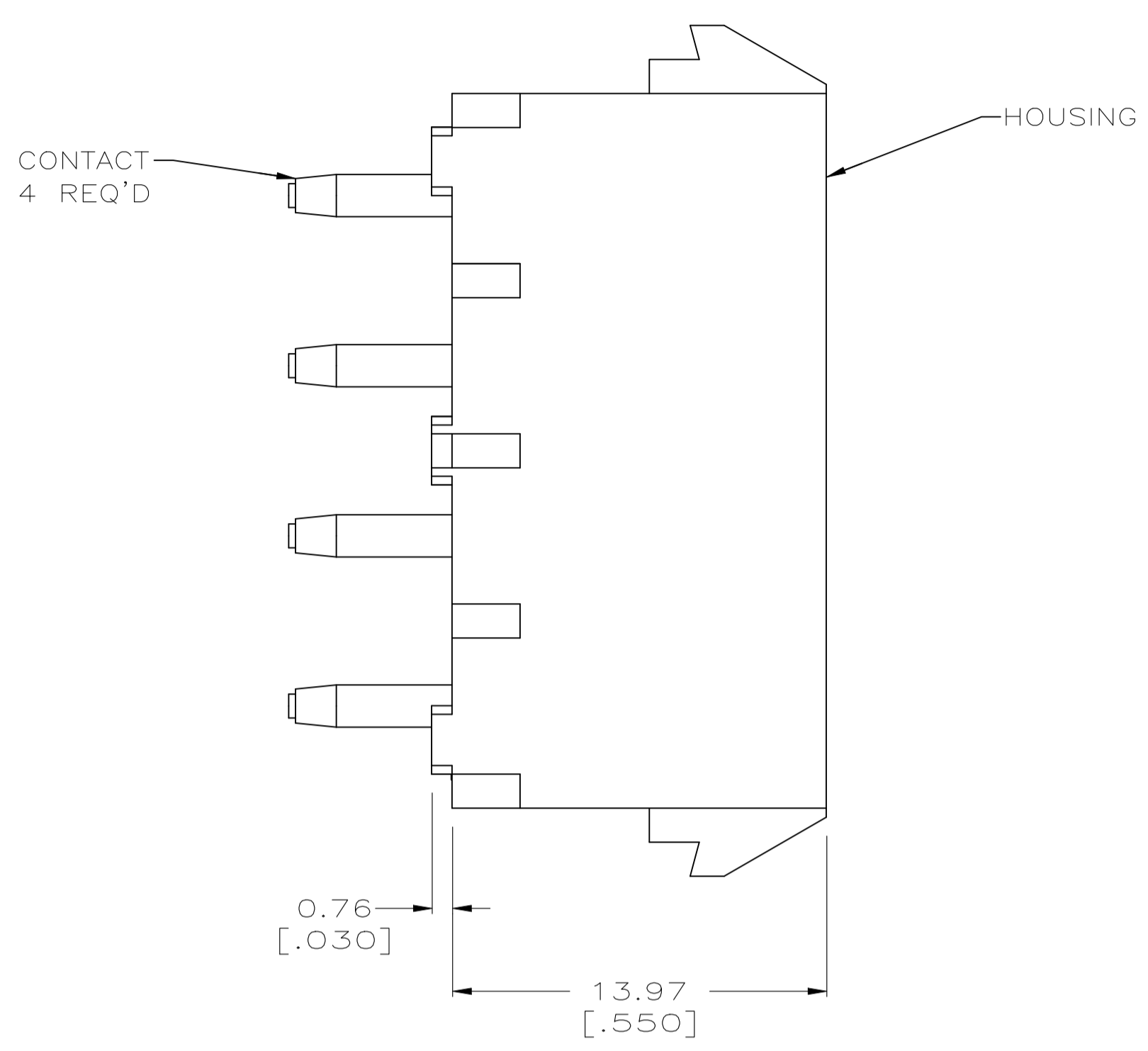
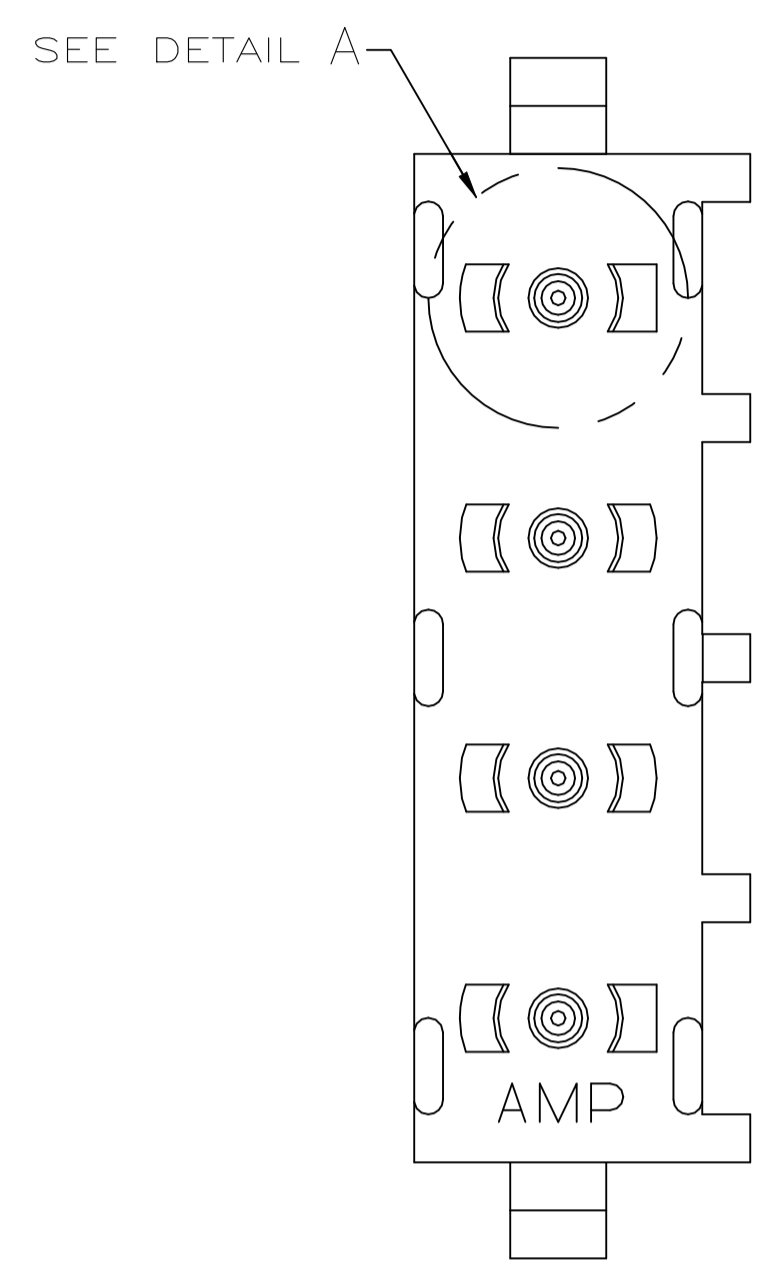
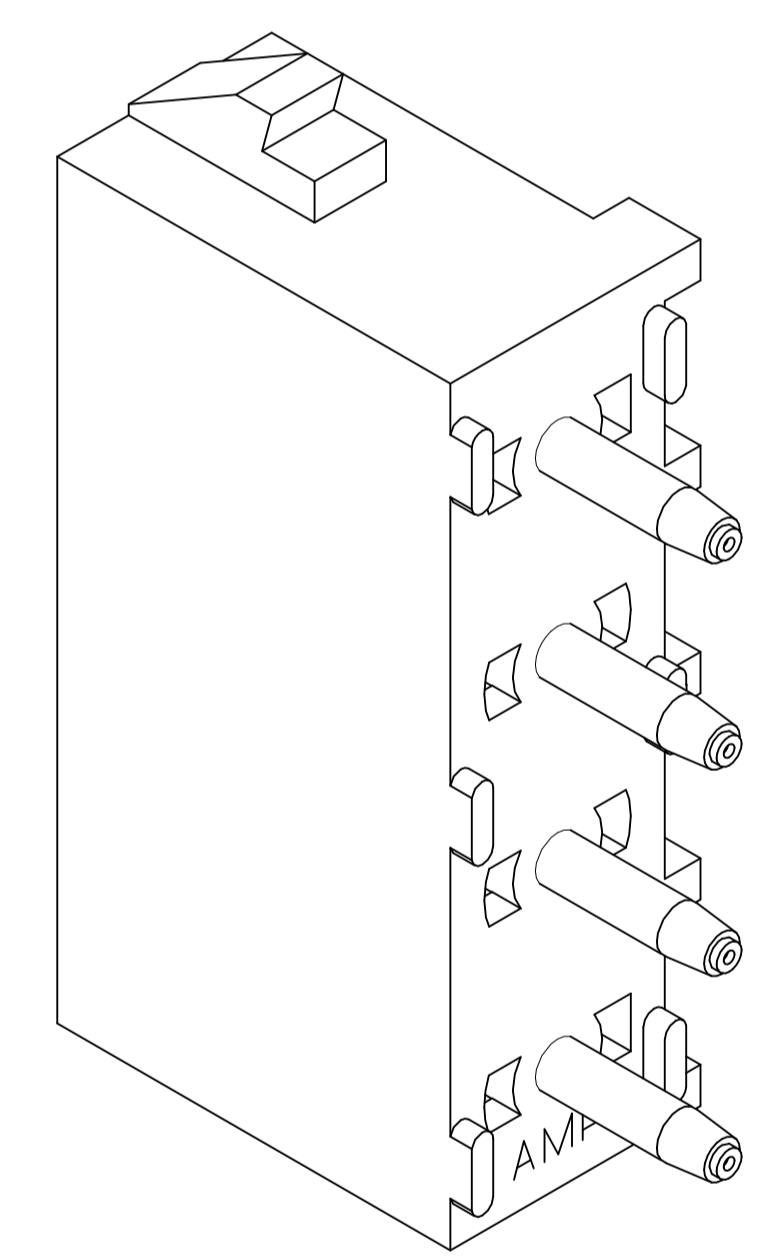
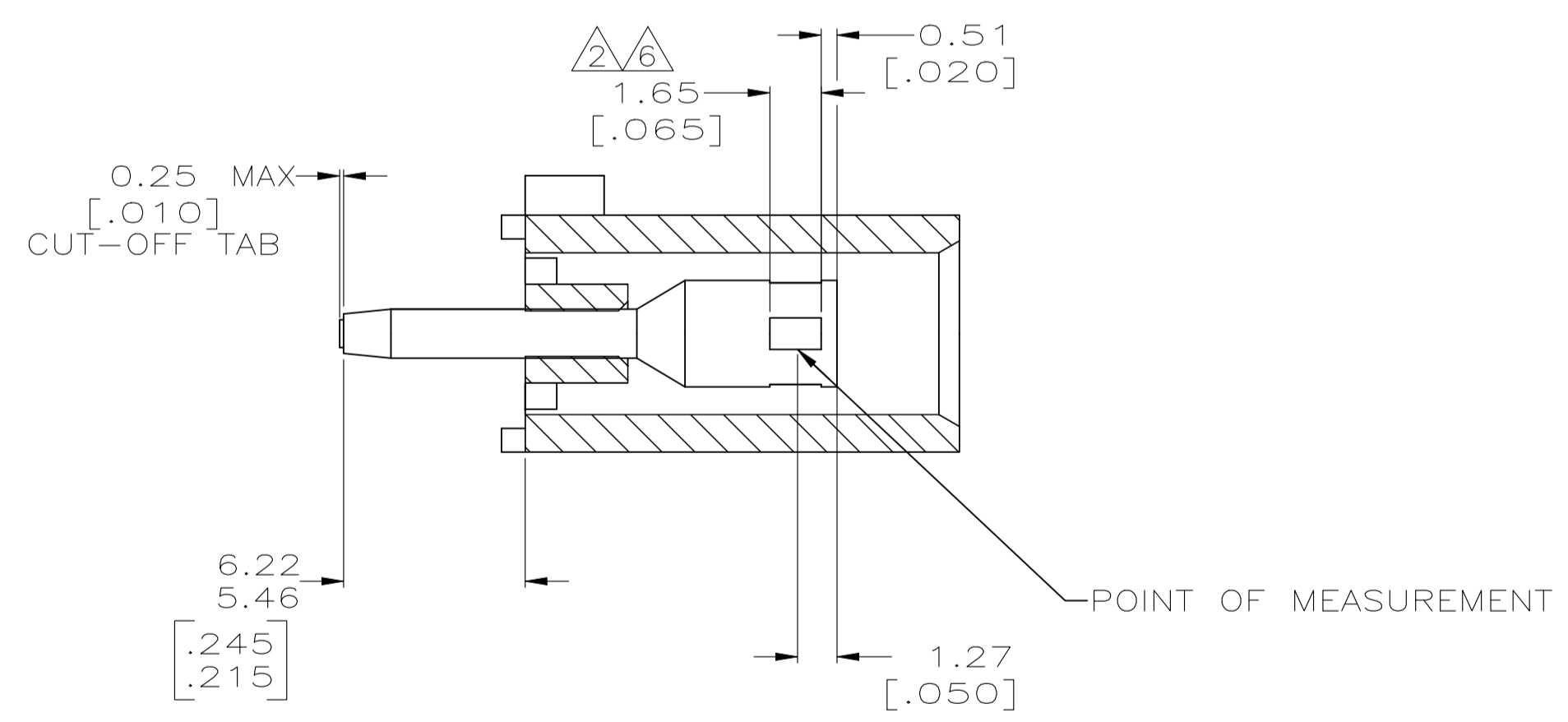

3-DIMENSIONAL MODEL NTS

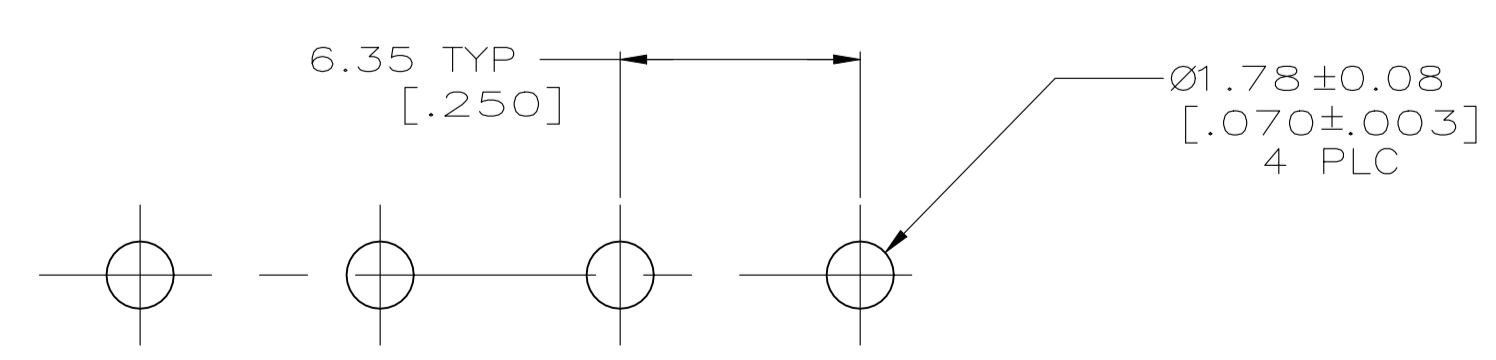
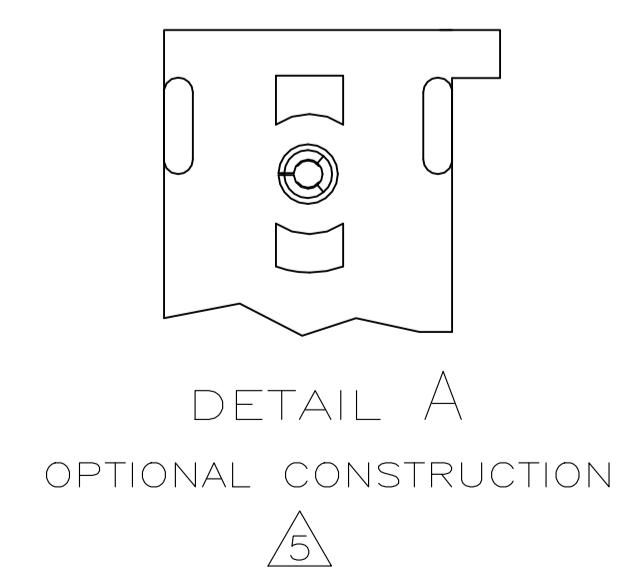

RECOMMENDED MOUNTING HOLE PATTERN FOR 3.18 [.125] THICK P.C. BOARD

PHOSPHOR BRONZE, GOLD	NYLON,UL94V-2,NATURAL	-350988-5-
PHOSPHOR BRONZE, PRE-TIN	NYLON,UL94V-2,NATURAL	350988-4
PHOSPHOR BRONZE, GOLD	NYLON,UL94V-2,NATURAL	-350988-3-
CONTACT MATERIAL AND FINISH	HOUSING MATERIAL	PART NUMBER

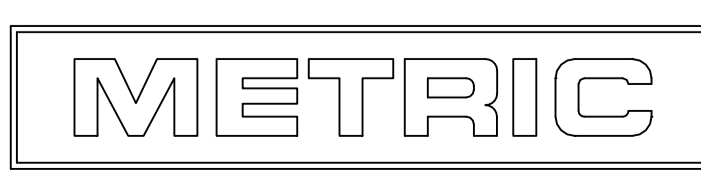

THIS DRAWING IS A CONTROLLED DOCUMENT.

DIMENSIONS: mm [INCHES]	TOLERANCES UNLESS OTHERWISE SPECIFIED:	DIN 9137 10-05-98	REV. LEWIS 10-05-98
0 PLC ± -	1 PLC ± -	2 PLC ± 0.13 [.005]	3 PLC ± -
4 PLC ± -	ANGLES ± 0±30'	TE Connectivity NAME: SOCKET HEADER ASSEMBLY, 4 CIRCUIT UNIVERSAL MATE-N-LOK™ SIZE: A1 CAGE CODE: 00779 DRAWING NO: 350988 WEIGHT: - RESTRICTED TO: - CUSTOMER DRAWING SCALE: 5:1 SHEET 1 OF 1 REV J2	