

THERMOCOUPLE TEMPERATURE SENSORS WITH CONNECTION HEAD UP TO 400 °C AND 600 °C

T01.03en

DESCRIPTION AND APPLICATION

These thermocouple temperature sensors are designed to measure temperatures up to 400 °C and 600 °C according to sensor type. When combining sensor and stainless steel central holder or thermowell, supplied as accessories, the sensors are possible to be used for temperature measurement in various applications in the industrial environment, for example even as pressure equipment within the meaning of the Government Regulation No. 26/2003 Coll. as amended. Maximum permitted operating pressure is 6.3 MPa (applies for case maximum length of up to 300 mm). The thermocouple temperature sensors are possible to be used for any control systems compatible with selected thermocouple type. Thermocouple temperature sensors type TCS 4x and TCS 6x meet ingress protection IP 54 in accordance with EN 60529, as amended. Thermocouple temperature sensors type TCS 64x and TCS 66x meet ingress protection IP 68 (1 bar) in accordance with EN 60529, as amended. Standard measuring range for temperature sensors TCS 4x and TCS 6x is -50 to 400 °C and for temperature sensors TCS 64x and TCS 66x is -50 to 600 °C. Temperature range can not be exceeded even for a brief period. Maximum ambient temperature around the connection head is 100 °C.

The thermocouple temperature sensors are intended for operation in chemically non-aggressive environment. The use must be chosen with regard to temperature resistance of connection head and chemical resistance of connection head and stem of the sensor.

ACCESSORIES

- stainless steel thermowell JPTS 41 for types TCS 4K, TCS 4J, TCS 6K, TCS 6J
- stainless steel thermowell JPTS 641 for types TCS 64K, TCS 64J, TCS 66K, TCS 66J
- metal central holder K 120
- screw with collet or cutting rings – if different lengths of stem immersion of the temperature sensor are set

DECLARATION, CERTIFICATES, CALIBRATION

Manufacturer provides **EU Declaration of Conformity**.

Calibration – The final metrological inspection – comparison with standards or working instruments – is carried out for all the products. Continuity of the standards and working measuring instruments is ensured within the meaning of the Section 5 of Act no.505/1990 on metrology. The manufacturer offers a possibility to supply the sensors calibrated in SENSIT s.r.o.'s laboratory (according to requirements of the EN ISO/IEC 17025 standard) or in an Accredited laboratory.

SPECIFICATIONS

Sensor type with smooth stem Sensor type with thread	TCS 4K TCS 6K	TCS 4J TCS 6J	TCS 64K TCS 66K	TCS 64J TCS 66J
Type of thermocouple	thermocouple "K"	thermocouple "J"	thermocouple "K"	thermocouple "J"
Measuring range	-50 to 400 °C		-50 to 600 °C, in a short time 650 °C	
Type of thermocouple	"J" and "K", single, double			
Accuracy class	standardly 2 in accordance with EN 60584 and DIN 43 710, further 1			
Version	with an isolated measuring point			
Diameter of the stem	6 mm			
Standard length of the stem	50, 100, 160, 220, 280, 340 and 400 mm			
Nominal pressure of the stem	PN 63 (with a thread) up to 400 °C and length of the stem 300 mm			
Thread types for variant with thread	G 1/2"; M 20 x 1.5; M 27 x 2; others on customer's requirements			
Material of the stem	stainless steel DIN 1.4301		stainless steel DIN 1.4571	
Recommended wire cross section	0.35 to 1.5 mm ²			
Ingress protection	IP 54 in accordance with EN 60529, as amended		IP 68 (1 bar) in accordance with EN 60529, as amended	
Type of connection head	LIMATHERM B		LIMATHERM NAA	
Material of the connection head	aluminium alloy			
Ambient temperature around the connection head	-30 to 100 °C		-30 to 150 °C	



WIRING DIAGRAM

Wiring diagram for temperature sensors up to 400 and 600 °C

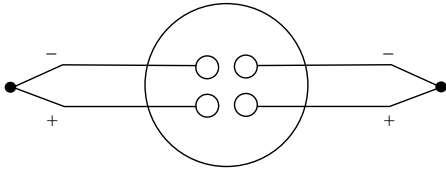

DIMENSIONAL DRAFT

Temperature sensors up to 400 °C
TCS 4x

TCS 4x

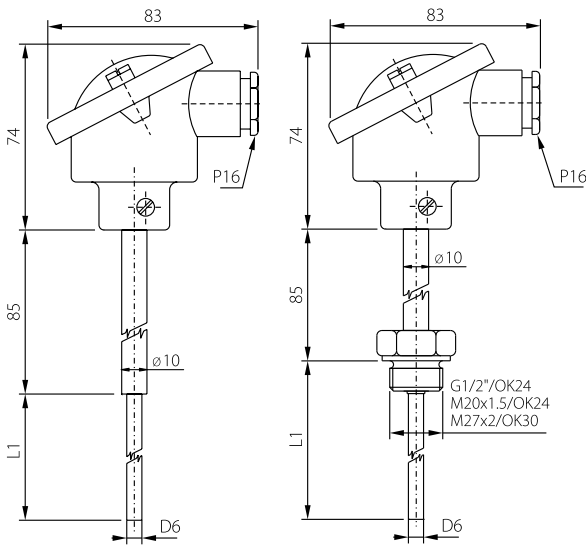

Temperature sensors up to 600 °C
TCS 64x

TCS 66x

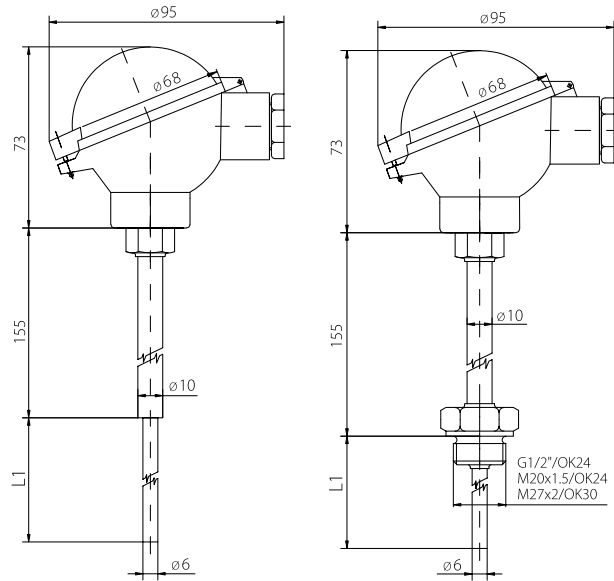

Accessories

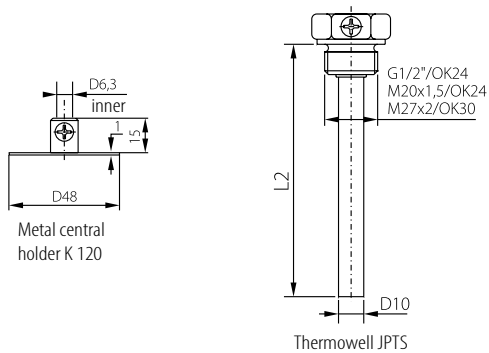

MODIFICATION AND CUSTOMIZATION

- variable stem design – length L1, diameter, case material
- type of thermowell thread

