

Sound Processors for BOOM BOX / Mini-component Stereo Sound Processors with Built-in 2-band Equalizers



BD3870FS, BD3871FS, BD3872FS, BD3873FS

No.10086EAT02

●Description

The Sound Processor with built-in 2 Band Equalizer, incorporates functions required for BOOM BOX and mini-component systems, such as input selector, input gain amp, volume, surround, tone (bass, treble), and loud speaker equalizer (BD3872FS only). These functions can be controlled through the two-wire serial control.

●Features

- 1) Using external components, center frequencies and Q factors of the bass characteristics are flexible.
- 2) Providing a mute switch onto one of the input pins allows cross-talk suppression.
- 3) A surround function can be constructed without external components.
- 4) Energy-saving design resulting in low current consumption, by utilizing the BiCMOS process

●Applications

BOOM BOX, mini-audio systems, and micro-audio systems.

●Line up matrix

Parameter	BD3870FS	BD3871FS	BD3873FS	BD3872FS
Input Gain	0, 6, 12, 18dB	24, 26, 28dB	18, 21, 24, 27dB	0, 5, 10, 19, 21, 23, 26, 28dB
Loud Speaker Equalizer (SEQ)	No	No	No	Yes
Input Selector	Three inputs	Three inputs	Three inputs	Five inputs
Volume	0 to -87dB/ 1dB step, -∞dB	0 to -87dB/ 1dB step, -∞dB	0 to -87dB/ 1dB step, -∞dB	0 to -87dB/ 1dB step, -∞dB
Equalizer	2 band (Bass, Treble)	2 band (Bass, Treble)	2 band (Bass, Treble)	2 band (Bass, Treble)
Surround	Yes	Yes	Yes	Yes
Serial Control	Two-wire serial	Two-wire serial	Two-wire serial	Two-wire serial
Package	SSOP-A24	SSOP-A24	SSOP-A24	SSOP-A32

●Absolute maximum ratings (Ta=25°C)

Parameter	Symbol	Ratings				Unit
		BD3870FS	BD3871FS	BD3873FS	BD3872FS	
Power Supply Voltage	Vcc	10	10	10	10	V
Power Dissipation	Pd	800 * ¹	800 * ¹	800 * ¹	950 * ²	mW
Operating Temperature Range	Topr	-25 to +75	-25 to +75	-25 to +75	-25 to +75	°C
Storage Temperature Range	Tstg	-55 to +125	-55 to +125	-55 to +125	-55 to +125	°C

*¹ Reduced by 8.0 mW/°C at 25°C or higher, when installed on the standard board (Size: 70 × 70 × 1.6mm).

*² Reduced by 9.5 mW/°C at 25°C or higher, when installed on the standard board (Size: 70 × 70 × 1.6mm).

●Operating voltage range

Parameter	Symbol	Ratings				Unit
		BD3870FS	BD3871FS	BD3873FS	BD3872FS	
Operating Voltage Range	Vcc	4.5 to 9.5	4.5 to 9.5	4.5 to 9.5	4.5 to 9.5	V

*It must function normally at Ta=25°C.

●Electrical characteristics

(Ta=25°C, VCC=8V, f=1kHz, Vi=200mVrms, RL=10kΩ, Rg=600Ω, Input Gain=0dB (BD3870FS, BD3872FS only), Input Gain=24dB (BD3871FS only), Input Gain=18dB (BD3873FS only), Volume=0dB, Bass=0dB, Treble=0dB, Surround=OFF, Loud Speaker Equalizer=OFF (BD3872FS only), unless otherwise noted)

Block	Parameter	Symbol	Limits			Unit	Condition
			Min.	Typ.	Max.		
Total	Circuit Current	IQ	-	8	21	mA	At no signal
	Total Output Voltage Gain	Gv	-2	0	2	dB	BD3870FS, BD3872FS Gv=20log(VOUT/VIN)
			22	24	26		BD3871FS Gv=20log(VOUT/VIN)
			16	18	20		BD3873FS Gv=20log(VOUT/VIN)
	Total Harmonic Distortion ratio	THD	-	0.01	0.1	%	BW=400 to 30kHz
	Maximum Output Voltage	Vom	1.6	2.1	-	Vrms	THD=1% BW=400 to 30kHz
	Total Output Noise Voltage	Vno	-	4.5	15	μVrms	BD3870FS, BD3872FS Rg=0Ω, BW=IHF-A
			-	40	80		BD3871FS, BD3873FS Rg=0Ω, BW=IHF-A
	Total Residual Noise Voltage	Vmno	-	4.5	15	μVrms	Rg=0Ω, BW=IHF-A Volume=-∞dB
	Cross-talk between Channels	CTC	-	-80	-70	dB	Rg=0Ω, BW=IHF-A VOUT=1Vrms
	Cross-talk between Selectors	CTS	-	-80	-70	dB	Rg=0Ω, BW=IHF-A
Input Impedance	Rin	35	50	65	kΩ	BD3870FS, BD3871FS, BD3873FS	
		70	100	130		BD3872FS	
Output Impedance	Rout	-	-	50	Ω		
Volume	Volume Control Range	VRI	-90	-87	-84	dB	VR=20log(VOUT/VIN)
	Maximum Volume Attenuation	Vmin	-	-	-90	dB	BW=IHF-A
	Volume Input Impedance	Rvin	39	56	73	kΩ	
Bass	Bass Boost Gain	GBB	12	14	16	dB	GB=20log(VOUT/VIN)
	Bass Cut Gain	GBC	-16	-14	-12	dB	GB=20log(VOUT/VIN)
	Bass Step Resolution	BR	-	2	-	dB	
Treble	Treble Boost Gain	GTB	10	12	14	dB	BD3870FS, BD3871FS, BD3873FS
			12	14	16		BD3872FS
	Treble Cut Gain	GTC	-14	-12	-10	dB	BD3870FS, BD3871FS, BD3873FS
			-16	-14	-12		BD3872FS
Treble Step Resolution	TR	-	2	-	dB		
Surround	Surround In-phase Gain	Vsur1	-2	0	2	dB	2ch in-phase inputs
	Surround Single-phase Gain	Vsur2	4.3	6.3	8.3	dB	1ch input, 1ch grounded
	Surround Opposite-phase Gain	Vsur3	8	10	12	dB	2ch opposite-phase inputs
SEQ	Loud Speaker Equalizer Gain (BD3872FS only)	Seq	3	5	7	dB	f=10kHz

* For measurement, VP-9690A (Average value wave detection, Effective value display) IHF-A filter by Matsushita Communication Industrial is used.

* Phase relation between Input/Output signal terminals is the same.

* Note: This IC is not designed to be radiation-resistant.

●Timing chart

1) Signal Timing Conditions

- Data is read on the rising edge of the clock.
 - Latch is read out on the falling edge of the clock.
 - Latch signal must end with the LOW state.
 - To avoid malfunctions, clock and data signals must terminate with the LOW state.
- 1byte=10bit

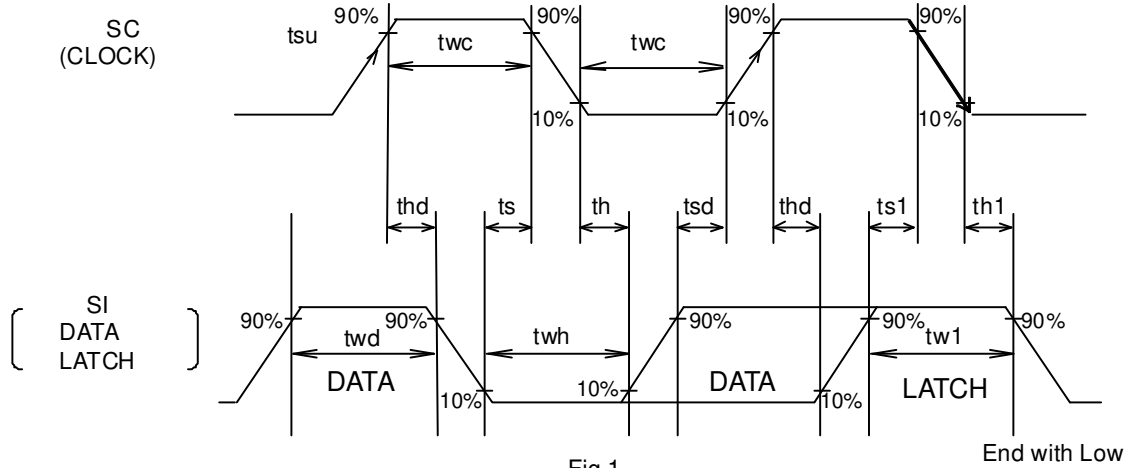

Parameter	Symbol	Limits			Unit
		Min.	Typ.	Max.	
Minimum Clock Width	Twc	2.0	-	-	μs
Minimum Data Width	twd	2.0	-	-	μs
Minimum Latch Width	Tw1	2.0	-	-	μs
Data Set-up Time (DATA→CLK)	Tsd	1.0	-	-	μs
Data Hold Time (CLK→DATA)	Thd	1.0	-	-	μs
Latch Set-up Time (CLK→LATCH)	Ts1	1.0	-	-	μs
Latch Hold Time (DATA→LATCH)	Th1	1.0	-	-	μs
Latch Low Set-up Time	Ts	1.0	-	-	μs
Latch Low Hold Width	Twh	2.0	-	-	μs

2) Voltage Conditions for Control Signals

Parameter	Limits			Unit	Condition
	Min.	Typ.	Max. (≤Vcc)		
“H” Input Voltage	2.2	-	5.5	V	Vcc=4.5 to 9.5V
“L” Input Voltage	0	-	1.0	V	Vcc=4.5 to 9.5V

3) Control Data Format List
 Basic Configuration of Control Data Format
 ← Data input direction

MSB								LSB	
D9	D8	D7	D6	D5	D4	D3	D2	D1	D0
Data								Select Address	

Control Data Format (BD3870FS, BD3871FS, BD3873FS)

← Data input direction

	D9	D8	D7	D6	D5	D4	D3	D2	D1	D0
(1)	Input Selector		Input Gain		Surround	*	*	*	0	0
(2)	Volume A				Volume B		*	0	1	
(3)	Bass Gain				Treble Gain				1	0
(4)	*	*	*	*	*	*	*	*	1	1

Control Data Format (BD3872FS)

← Data input direction

	D9	D8	D7	D6	D5	D4	D3	D2	D1	D0
(1)	Input Gain			Input Selector			*	*	0	0
(2)	Volume A				Volume B		*	0	1	
(3)	Bass Gain				Treble Gain				1	0
(4)	*	*	*	*	*	*	Surround	SEQ	1	1

- "*" indicates 0 or 1.
- By changing the setting of Select Address, three or four different control formats (BD3871FS, BD3872FS, BD3873FS, plus BD3872FS) are selectable.
- In every power-on sequence, all of the address data must be initialized.

Example:

←Input direction

MSB	LSB	MSB	LSB	MSB	LSB	MSB	LSB
Data(1)	L	Data(2)	L	Data(3)	L	Data(4)	L

"L" indicates a latch.

- After power-on, for the second and subsequent times, only the necessary data can be selected for setting.

Example: When changing the volume,

←Input direction

MSB	LSB
Data(2)	L

"L" indicates a latch.

●Block diagram, application circuit, pin assignment (BD3870FS, BD3871FS, BD3873FS)

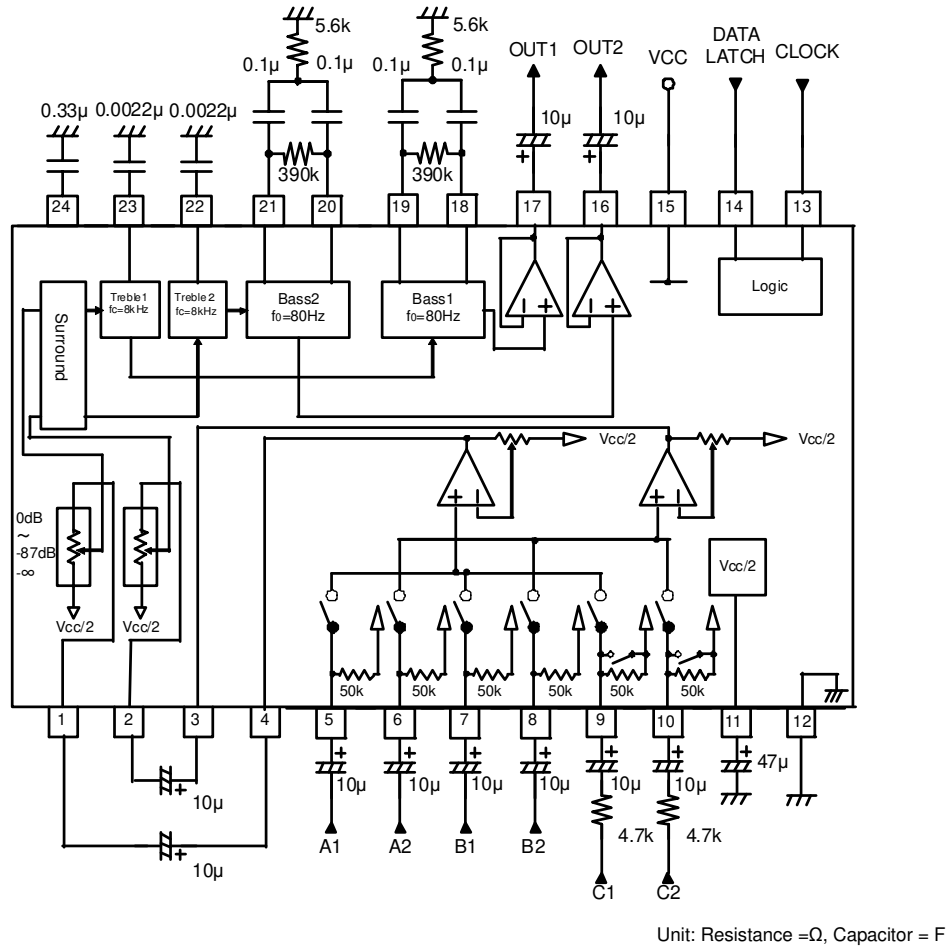

Fig.2

●Pin description (BD3870FS, BD3871FS, BD3873FS)

Pin No.	Pin Name	Description	Pin No.	Pin Name	Description
1	VIN1	1ch volume input pin	13	SC	Serial clock input pin
2	VIN2	2ch volume input pin	14	SI	Serial data input pin
3	SEL2	2ch input selector output pin	15	VCC	Power supply pin
4	SEL1	1ch input selector output pin	16	OUT2	2ch output pin
5	A1	1ch input pin A	17	OUT1	1ch output pin
6	A2	2ch input pin A	18	BOUT1	1ch bass filter setting pin
7	B1	1ch input pin B	19	BNF1	1ch bass filter setting pin
8	B2	2ch input pin B	20	BOUT2	2ch bass filter setting pin
9	C1	1ch input pin C	21	BNF2	2ch bass filter setting pin
10	C2	2ch input pin C	22	TNF2	2ch treble filter setting pin
11	FILTER	1/2 VCC pin	23	TNF1	1ch treble filter setting pin
12	GND	Ground pin	24	CAP	Time constant setting pin for absorbing surround switching shock sound

●Block diagram, application circuit, pin assignment (BD3872FS)

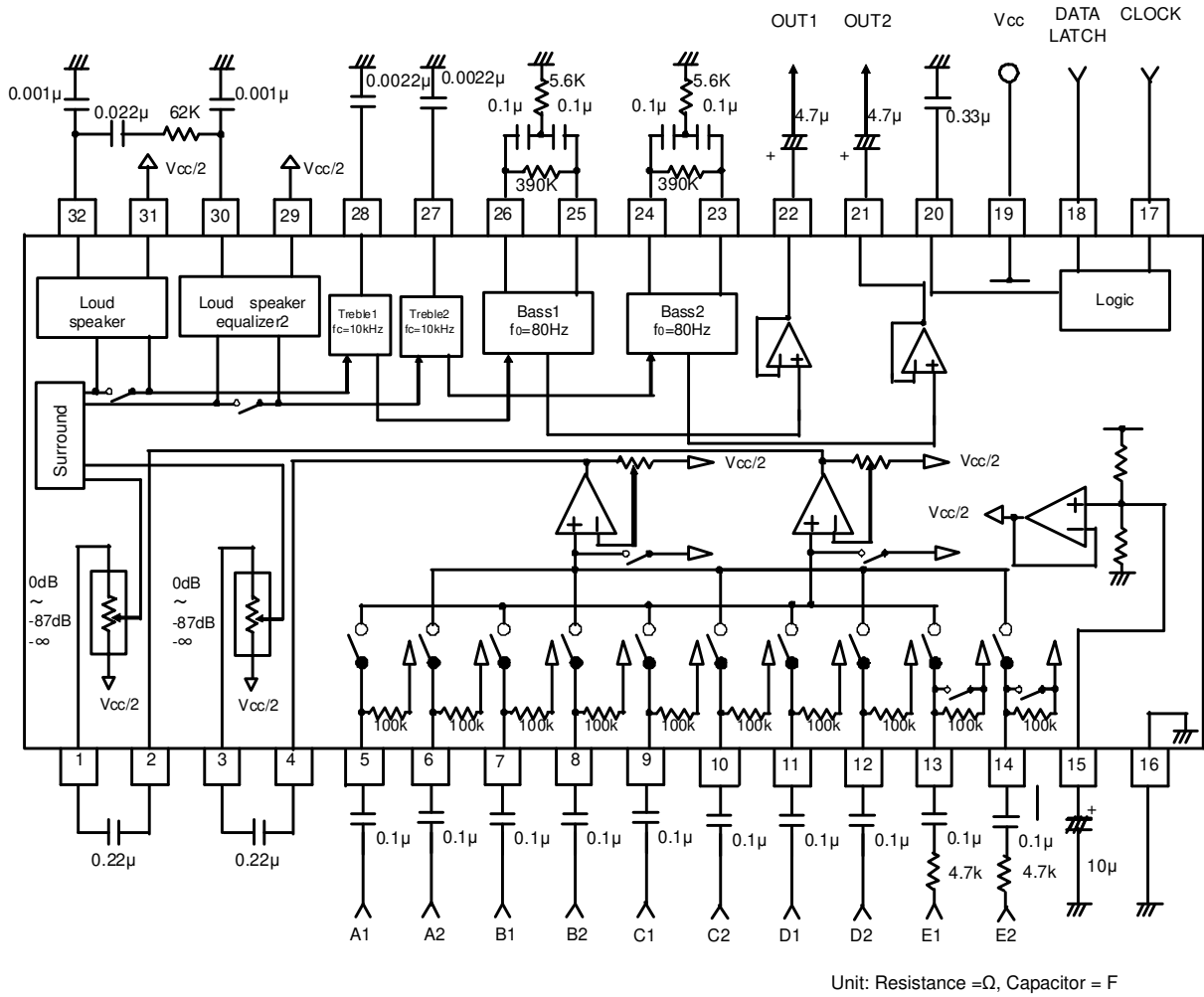
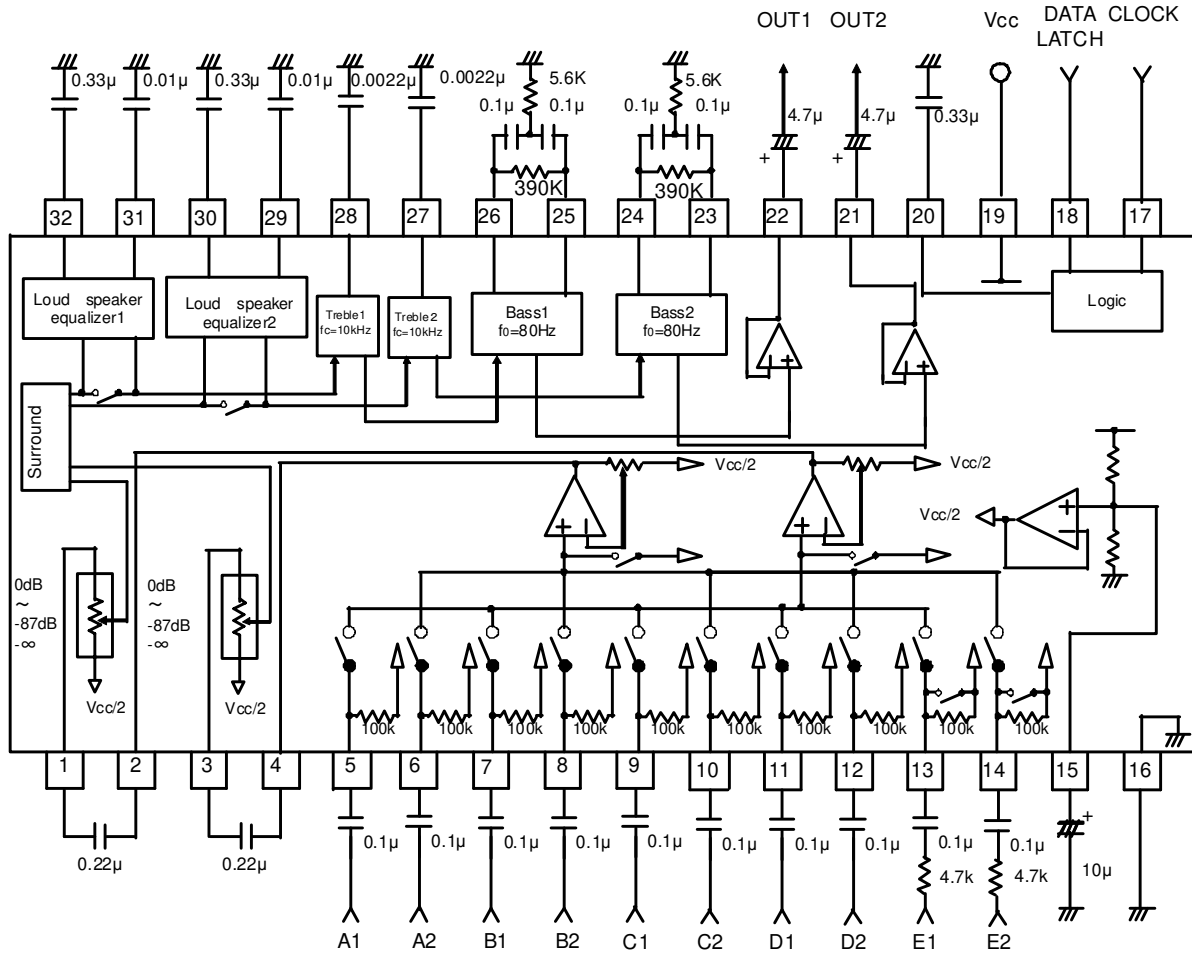

Fig.3 Application to Cinema Surround



Unit: Resistance =Ω, Capacitor = F

Fig.4 Application to Loud Speaker Equalizer

●Pin description (BD3872FS)

Pin No.	Pin Name	Description	Pin No.	Pin Name	Description
1	VIN1	1ch volume input pin	17	SC	Serial clock input pin
2	SEL1	1ch input selector output pin	18	SI	Serial data input pin
3	VIN2	2ch volume input pin	19	VCC	Power supply pin
4	SEL2	2ch input selector output pin	20	CAP	Time constant setting pin for absorbing switching shock sound
5	A1	1ch input pin A	21	OUT2	2ch output pin
6	A2	2ch input pin A	22	OUT1	1ch output pin
7	B1	1ch input pin B	23	BOUT2	2ch bass filter setting pin
8	B2	2ch input pin B	24	BNF2	2ch bass filter setting pin
9	C1	1ch input pin C	25	BOUT1	1ch bass filter setting pin
10	C2	2ch input pin C	26	BNF1	1ch bass filter setting pin
11	D1	1ch input pin D	27	TNF2	2ch treble filter setting pin
12	D2	2ch input pin D	28	TNF1	1ch treble filter setting pin
13	E1	1ch input pin E	29	SOUT2	2ch cinema surround or SEQ setting pin
14	E2	2ch input pin E	30	SQI2	2ch cinema surround or SEQ setting pin
15	FILTER	1/2 VCC pin	31	SOUT1	1ch cinema surround or SEQ setting pin
16	GND	Ground pin	32	SQI1	1ch cinema surround or SEQ setting pin

●Description of operations

1) Bass filter

Using external components, center frequencies and Q factors of the bass characteristics are flexible

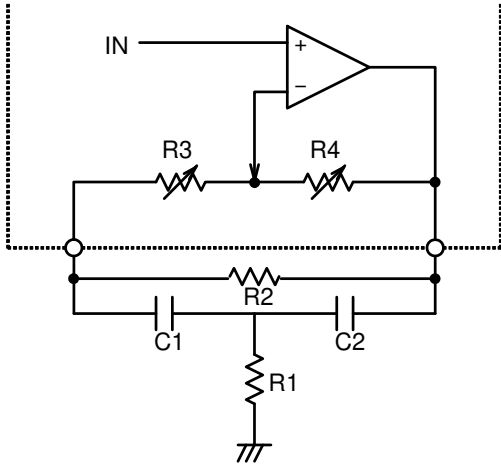

Fig.5

$$f_0 = \frac{1}{2\pi \sqrt{\frac{R1R2(R3 + R4)C1C2}{R2 + R3 + R4}}} \text{ (Hz)}$$

$$Q = \frac{\sqrt{\frac{R1R2R4C1C2}{R2 + R3 + R4}}}{R1(C1 + C2)}$$

$$G(\text{boost}) = 20 \log \frac{\frac{R2(R3 + R4)}{R1(R2 + R3 + R4)} + \frac{C2}{C1} + 1}{\frac{R2R3}{R1(R2 + R3 + R4)} + \frac{C2}{C1} + 1} \text{ (dB)}$$

$$G_{\text{cut}} = 20 \log \frac{\frac{R2R3}{R1(R2 + R3 + R4)} + \frac{C2}{C1} + 1}{\frac{R1(R2 + R3 + R4)}{R2(R3 + R4)} + \frac{C2}{C1} + 1} \text{ (dB)}$$

Standard values of R3, R4 (reference)
(R1=5.6kΩ, R2=390kΩ, C1=C2=0.1μF)

Bass Boost Cut Amount	Resistance (kΩ) * Typ.	
	R3	R4
0dB	77.64	0
2dB	58.90	18.73
4dB	44.02	33.60
6dB	32.20	45.42
8dB	22.82	54.80
10dB	15.36	62.26
12dB	9.44	68.18
14dB	4.78	72.84

* The actual boost cut amount may deviate from the standard values in some degree.

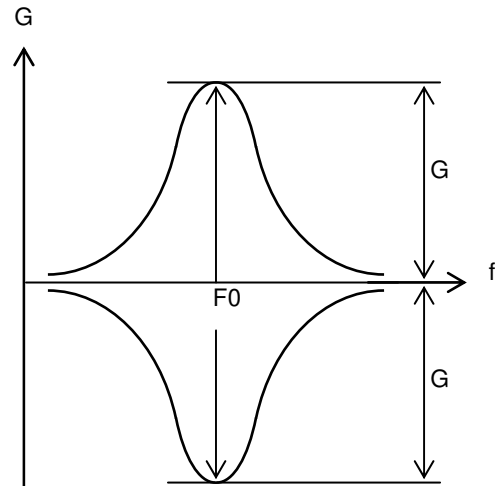

Fig.6

2) Treble filter

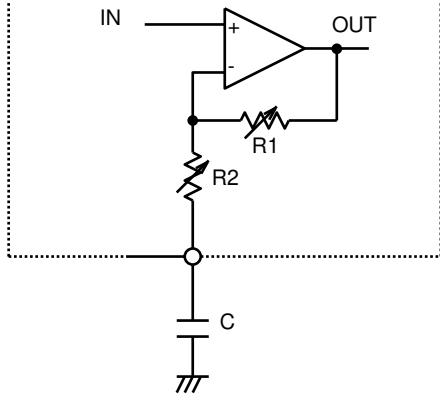

Fig.7

$$f_c = \frac{1}{2\pi R_2 C} \text{ (Hz)}$$

$$G \text{ (boost)} = 20 \log \frac{R_1 + R_2 + Z_c}{R_2 + Z_c} \text{ (dB)}$$

$$G \text{ (cut)} = 20 \log \frac{R_2 + Z_c}{R_1 + R_2 + Z_c} \text{ (dB)}$$

$$Z_c = \frac{1}{j\omega c} \text{ (\Omega)}$$

Standard values of R1, R2 (reference)

Treble Boost Cut Amount	Resistance (kΩ) * Typ.	
	R1	R2
0dB	0	36.28
2dB	7.46	28.82
4dB	13.39	22.89
6dB	18.10	18.18
8dB	21.84	14.44
10dB	24.81	11.47
12dB	27.20	9.08
14dB (BD3872FS only)	29.04	7.24

* The actual boost cut amount may deviate from the standard values in some degree.

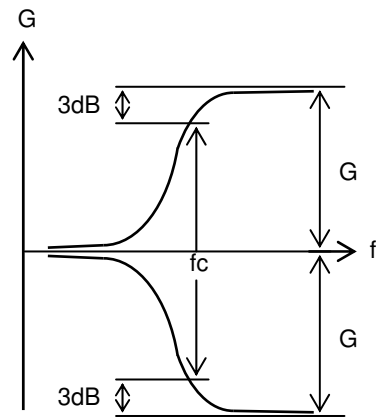

Fig.8

3) Matrix surround

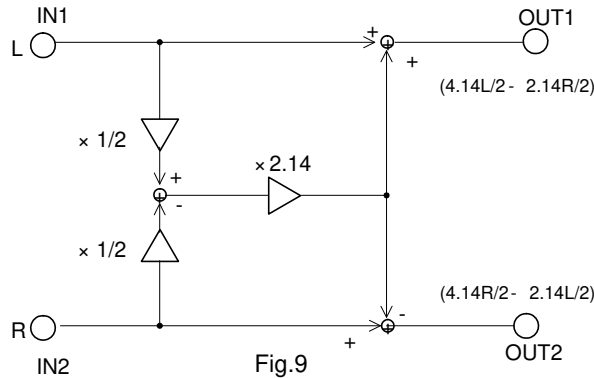

Fig.9

Matrix surround is constructed as shown above. Gains are defined as follows:

In-phase Gain: Gains obtained on OUT1 and OUT2 against IN1 when inputting a signal of the equivalent level and in-phase (L=R) to IN1 and IN2.

$$\frac{OUT1}{IN1} = \frac{OUT2}{IN2} = \left(\frac{4.14}{2} L - \frac{2.14}{2} L \right) / L = 1 \quad 20 \log 1 = 0 \text{ (dB)}$$

Single-phase Gain: Gains obtained on OUT1 and OUT2 against IN1 when inputting a signal to IN1 and AC-grounding IN2 (R=0).

$$\frac{OUT1}{IN1} = \frac{4.14}{2} L / L = 2.07 \quad 20 \log 2.07 = 6.3 \text{ (dB)}$$

$$\frac{OUT2}{IN1} = -\frac{2.14}{2} L / L = -1.07 \quad 20 \log |-1.07| = 0.59 \text{ (dB)}$$

Opposite-phase Gain: Gains obtained on OUT1 and OUT2 against IN1 when inputting signals of the equivalent level and opposite-phase (L-R) to IN1 and IN2.

$$\frac{OUT1}{IN1} = \frac{OUT2}{IN2} = \left(\frac{4.14}{2} L + \frac{2.14}{2} L \right) / L = 3.14 \quad 20 \log 3.14 = 10 \text{ (dB)}$$

1) Sound generation using Loud Speaker Equalizer (BD3872FS)

Using external components, one of the following two functions can be established; one having an effect to localize the vocal forward and enhance it (Loud Speaker Equalizer) and the other having an effect to clarify the vocal quality and improve the Articulation Index (Cinema Surround). Those characteristic values can be adjusted by choosing the external components with desirable constants. Details of above two functions are described below:

◎Cinema Surround

Constructing the external components as shown below allows the vocals to be moved forward and enhanced. Surround effect with enhanced vocal is achieved by turning on the built-in surround simultaneously. Merging this effect, while playing movies on a DVD player, will make vocal listening clearer and surround effect more impactful.

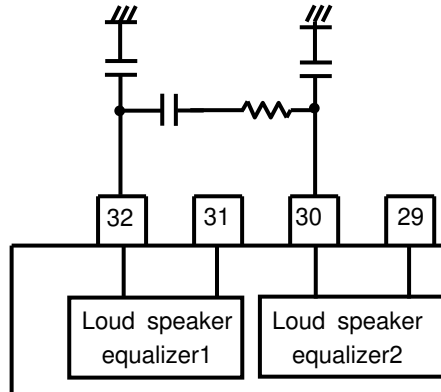

Fig.10

◎Loud Speaker Equalizer (SEQ)

BOOM BOX and Micro-sound systems are often restricted to using small-diameter speakers because of location space. These speakers, where the vocal range are attenuated, may give an impression of having a muffled vocal sound with respect to its audibility. Using the Loud Speaker Equalizer, the vocal quality which degrades in small-diameter speakers, can be improved and the Articulation Index is also increased.

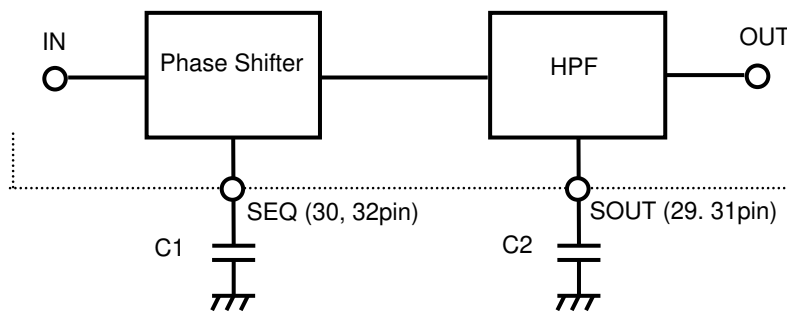

Fig.11

- C1 can be selected to determine the frequency where the phase should be inverted.

C1	Frequency where the phase is inverted
Larger value	Set to the lower frequency side
Smaller value	Set to the higher frequency side

- C2 can be selected to determine the HPF cut-off frequency f_c . The SEQ gain remains constant.

$$f_c = \frac{1}{2\pi RC} \quad (\text{Hz})$$

(Where R is a built-in resistance of 10kΩ)

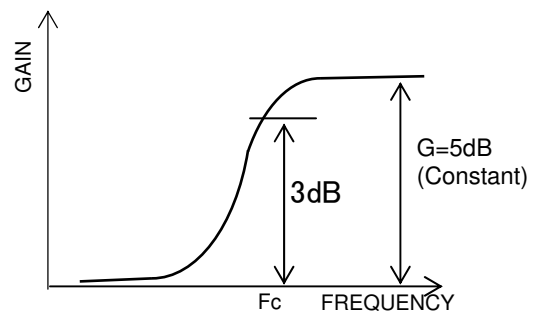

Fig.12

●Reference data

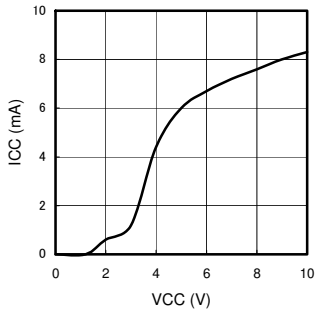

Fig.13 Circuit Current - Power Supply Voltage

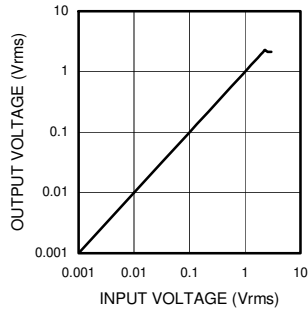

Fig.14 Output Voltage - Input Voltage (BD3870FS)

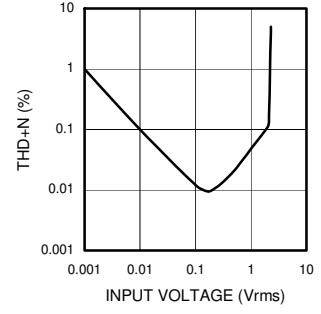

Fig.15 Total Harmonic Distortion ratio - Input Voltage (BD3870FS)

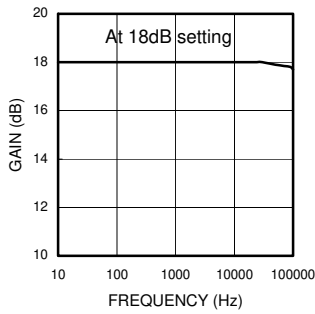

Fig.16 Current Gain - Frequency (BD3870FS, BD3873FS)

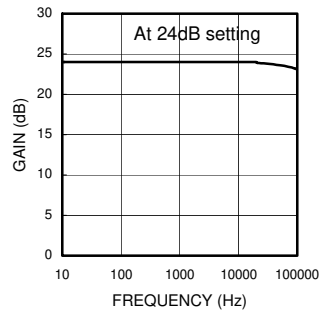

Fig.17 Voltage Gain - Frequency (BD3871FS)

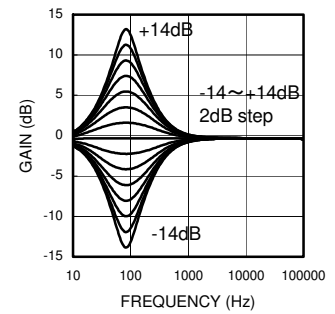

Fig.18 Bass Gain - Frequency

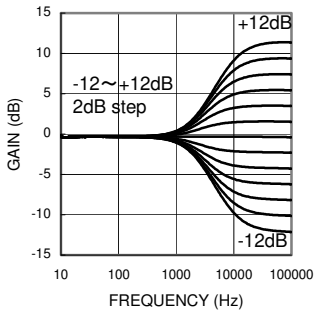

Fig.19 Treble Gain - Frequency (BD3870FS, BD3871FS, BD3873FS)

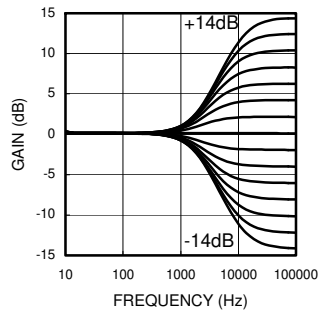

Fig.20 Treble Gain - Frequency (BD3872FS)

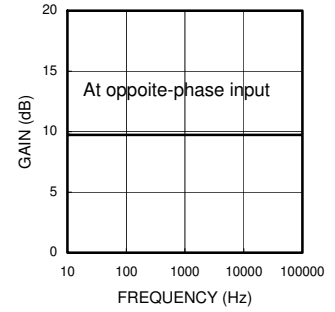

Fig.21 Surround Gain - Frequency

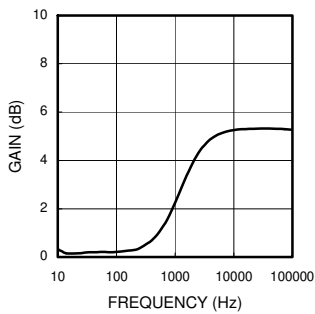

Fig.22 Treble Gain - Frequency (BD3872FS)

●Notes for use

- 1) Numbers and data in entries are representative design values and are not guaranteed values of the items.
- 2) Although ROHM is confident that the example application circuit reflects the best possible recommendations, be sure to verify circuit characteristics for your particular application. Modification of constants for other externally connected circuits may cause variations in both static and transient characteristics for external components as well as this Rohm IC. Allow for sufficient margins when determining circuit constants.
- 3) Absolute maximum ratings
Use of the IC in excess of absolute maximum ratings, such as the applied voltage or operating temperature range (Topr), may result in IC damage. Assumptions should not be made regarding the state of the IC (short mode or open mode) when such damage is suffered. A physical safety measure, such as a fuse, should be implemented when using the IC at times where the absolute maximum ratings may be exceeded.
- 4) GND potential
Ensure a minimum GND pin potential in all operating conditions. Make sure that no pins are at a voltage below the GND at any time, regardless of whether it is a transient signal or not.
- 5) Thermal design
Perform thermal design, in which there are adequate margins, by taking into account the permissible dissipation (Pd) in actual states of use.
- 6) Short circuit between terminals and erroneous mounting
Pay attention to the assembly direction of the ICs. Wrong mounting direction or shorts between terminals, GND, or other components on the circuits, can damage the IC.
- 7) Operation in strong electromagnetic field
Using the ICs in a strong electromagnetic field can cause operation malfunction.
- 8) Power-ON RESET
A built-in circuit for performing initialization inside the IC at power-ON is provided. In unstable systems it is recommended that the data shall be sent to all the addresses during power-ON, until this operation cycle is completed. Mute should be applied during this cycle.

Function	Initial Condition
Input Selector	Input A
Input Gain	0dB
Loud Speaker Equalizer (BD3872FS only)	OFF
Volume	-∞dB
Surround	OFF
Treble Gain	0dB
Bass Gain	0dB

- 9) 2-wire serial control
For the CL and DA terminals, the patterned and other wirings should be routed as not to cause interference with the analog-signal-related lines.
- 10) Switching between functions
Shock sound is absorbed when switching between the volume, bass, and treble functions.
- 11) Input coupling capacitor
As described in the figure below, low frequency characteristics are determined depending on the external capacitor value for input coupling, and the input impedance value inside the IC.

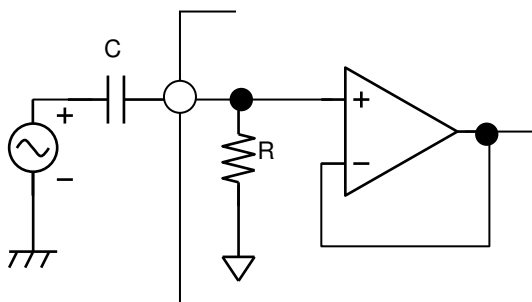
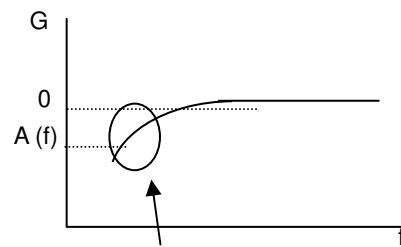

Fig.23



$$A(f) = \sqrt{\frac{(2\pi fCR)^2}{1+(2\pi fCR)^2}}$$

Fig.24

12) Switching noise

For Surround and Loud Speaker Equalizer (BD3872FS only), external capacitor C is attached to the CAP pin as a measure to control the switching noise. In the application circuit, a constant value as an example, is indicated by the CAP pin. The time constant, which is used to charge/discharge the external capacitor C (varying between V_{be} to $5V_{be}$ (2.65V)) on the CAP pin, controls the soft switching operation. The switching time constant T is stated as $T=2.55 \times 10^5 \times C$. V_{be} has a temperature characteristic and may affect the time constant T.

13) Input Selector and Input Gain

When setting/changing Input Selector or Input Gain, the soft switching operation does not function and therefore noise is not controlled. For this reason, it is recommended to provide a mute circuit constructed of the external components for the set design.

MUTE setting example

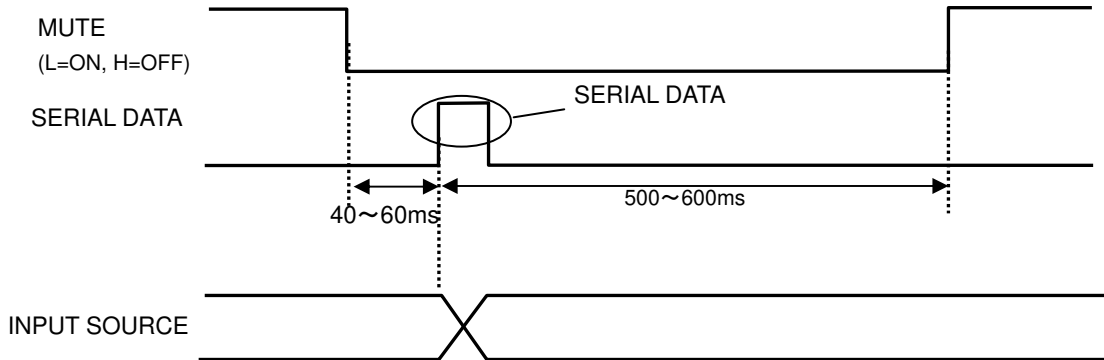
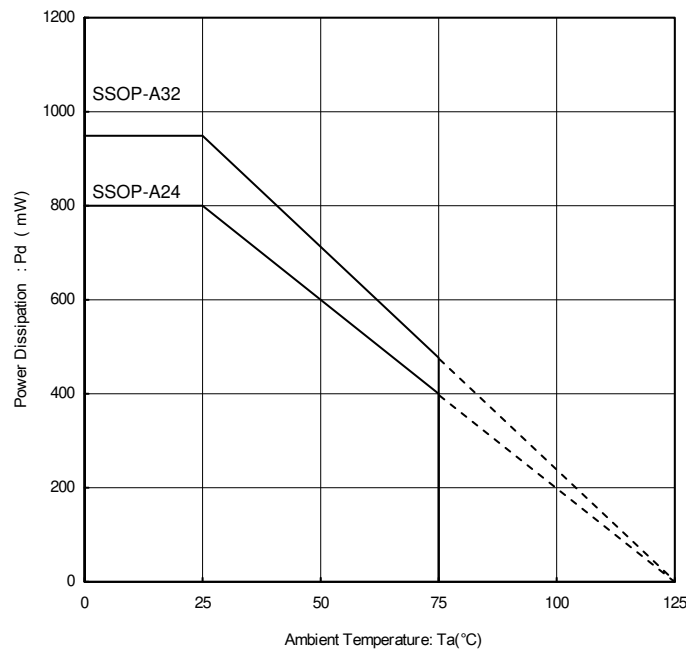

Fig.25

● Thermal Derating Curve



When installed ROHM standard board
(70 × 70 × 1.6mm Glass epoxy board)

Fig.26

●Ordering part number

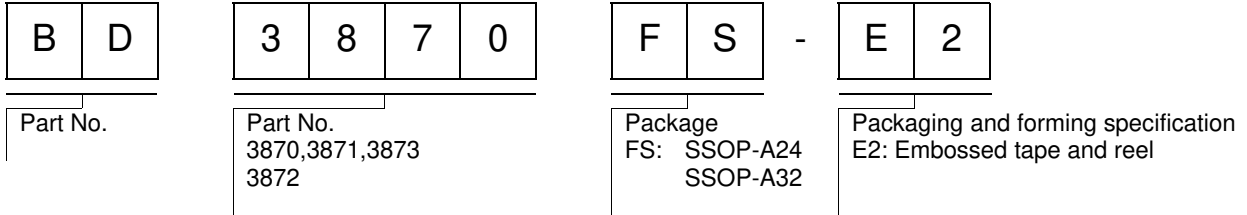

SSOP-A24

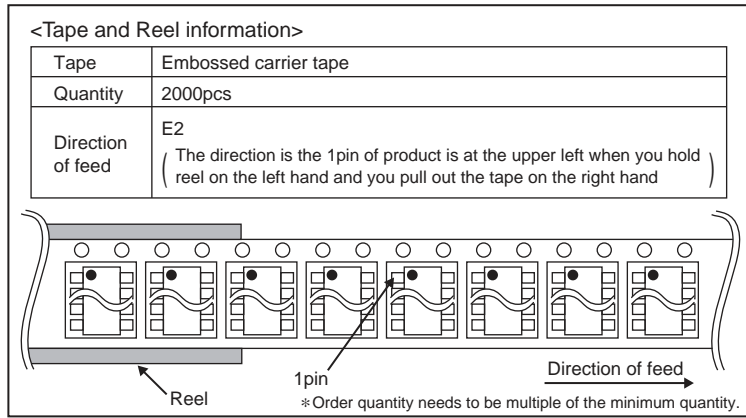
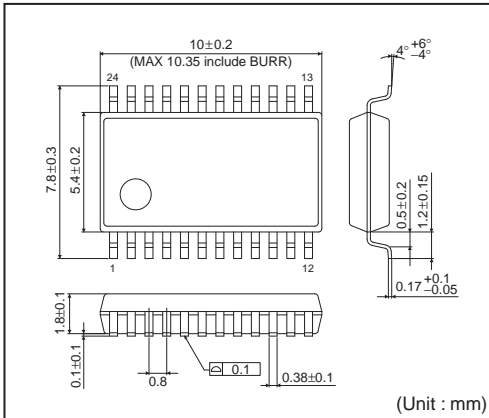

SSOP-A32

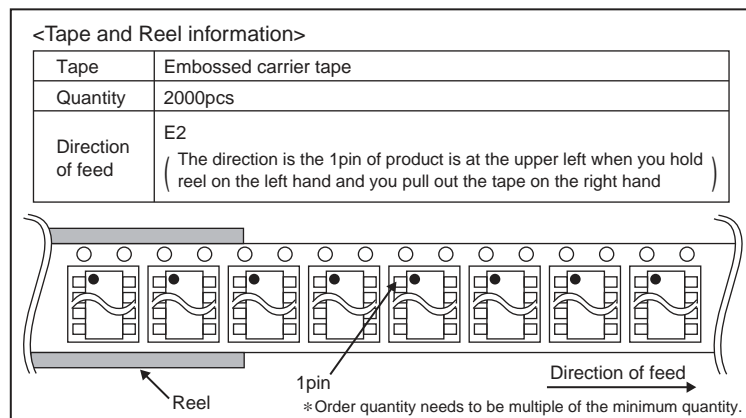
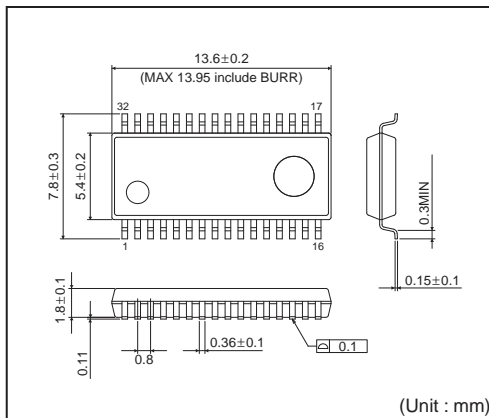

Notice

Precaution on using ROHM Products

- Our Products are designed and manufactured for application in ordinary electronic equipments (such as AV equipment, OA equipment, telecommunication equipment, home electronic appliances, amusement equipment, etc.). If you intend to use our Products in devices requiring extremely high reliability (such as medical equipment ^(Note 1), transport equipment, traffic equipment, aircraft/spacecraft, nuclear power controllers, fuel controllers, car equipment including car accessories, safety devices, etc.) and whose malfunction or failure may cause loss of human life, bodily injury or serious damage to property ("Specific Applications"), please consult with the ROHM sales representative in advance. Unless otherwise agreed in writing by ROHM in advance, ROHM shall not be in any way responsible or liable for any damages, expenses or losses incurred by you or third parties arising from the use of any ROHM's Products for Specific Applications.

(Note1) Medical Equipment Classification of the Specific Applications

JAPAN	USA	EU	CHINA
CLASS III	CLASS III	CLASS II b	CLASS III
CLASS IV		CLASS III	

- ROHM designs and manufactures its Products subject to strict quality control system. However, semiconductor products can fail or malfunction at a certain rate. Please be sure to implement, at your own responsibilities, adequate safety measures including but not limited to fail-safe design against the physical injury, damage to any property, which a failure or malfunction of our Products may cause. The following are examples of safety measures:
 - Installation of protection circuits or other protective devices to improve system safety
 - Installation of redundant circuits to reduce the impact of single or multiple circuit failure
- Our Products are designed and manufactured for use under standard conditions and not under any special or extraordinary environments or conditions, as exemplified below. Accordingly, ROHM shall not be in any way responsible or liable for any damages, expenses or losses arising from the use of any ROHM's Products under any special or extraordinary environments or conditions. If you intend to use our Products under any special or extraordinary environments or conditions (as exemplified below), your independent verification and confirmation of product performance, reliability, etc. prior to use, must be necessary:
 - Use of our Products in any types of liquid, including water, oils, chemicals, and organic solvents
 - Use of our Products outdoors or in places where the Products are exposed to direct sunlight or dust
 - Use of our Products in places where the Products are exposed to sea wind or corrosive gases, including Cl₂, H₂S, NH₃, SO₂, and NO₂
 - Use of our Products in places where the Products are exposed to static electricity or electromagnetic waves
 - Use of our Products in proximity to heat-producing components, plastic cords, or other flammable items
 - Sealing or coating our Products with resin or other coating materials
 - Use of our Products without cleaning residue of flux (even if you use no-clean type fluxes, cleaning residue of flux is recommended); or Washing our Products by using water or water-soluble cleaning agents for cleaning residue after soldering
 - Use of the Products in places subject to dew condensation
- The Products are not subject to radiation-proof design.
- Please verify and confirm characteristics of the final or mounted products in using the Products.
- In particular, if a transient load (a large amount of load applied in a short period of time, such as pulse. is applied, confirmation of performance characteristics after on-board mounting is strongly recommended. Avoid applying power exceeding normal rated power; exceeding the power rating under steady-state loading condition may negatively affect product performance and reliability.
- De-rate Power Dissipation (Pd) depending on Ambient temperature (Ta). When used in sealed area, confirm the actual ambient temperature.
- Confirm that operation temperature is within the specified range described in the product specification.
- ROHM shall not be in any way responsible or liable for failure induced under deviant condition from what is defined in this document.

Precaution for Mounting / Circuit board design

- When a highly active halogenous (chlorine, bromine, etc.) flux is used, the residue of flux may negatively affect product performance and reliability.
- In principle, the reflow soldering method must be used; if flow soldering method is preferred, please consult with the ROHM representative in advance.

For details, please refer to ROHM Mounting specification

Precautions Regarding Application Examples and External Circuits

1. If change is made to the constant of an external circuit, please allow a sufficient margin considering variations of the characteristics of the Products and external components, including transient characteristics, as well as static characteristics.
2. You agree that application notes, reference designs, and associated data and information contained in this document are presented only as guidance for Products use. Therefore, in case you use such information, you are solely responsible for it and you must exercise your own independent verification and judgment in the use of such information contained in this document. ROHM shall not be in any way responsible or liable for any damages, expenses or losses incurred by you or third parties arising from the use of such information.

Precaution for Electrostatic

This Product is electrostatic sensitive product, which may be damaged due to electrostatic discharge. Please take proper caution in your manufacturing process and storage so that voltage exceeding the Products maximum rating will not be applied to Products. Please take special care under dry condition (e.g. Grounding of human body / equipment / solder iron, isolation from charged objects, setting of Ionizer, friction prevention and temperature / humidity control).

Precaution for Storage / Transportation

1. Product performance and soldered connections may deteriorate if the Products are stored in the places where:
 - [a] the Products are exposed to sea winds or corrosive gases, including Cl₂, H₂S, NH₃, SO₂, and NO₂
 - [b] the temperature or humidity exceeds those recommended by ROHM
 - [c] the Products are exposed to direct sunshine or condensation
 - [d] the Products are exposed to high Electrostatic
2. Even under ROHM recommended storage condition, solderability of products out of recommended storage time period may be degraded. It is strongly recommended to confirm solderability before using Products of which storage time is exceeding the recommended storage time period.
3. Store / transport cartons in the correct direction, which is indicated on a carton with a symbol. Otherwise bent leads may occur due to excessive stress applied when dropping of a carton.
4. Use Products within the specified time after opening a humidity barrier bag. Baking is required before using Products of which storage time is exceeding the recommended storage time period.

Precaution for Product Label

QR code printed on ROHM Products label is for ROHM's internal use only.

Precaution for Disposition

When disposing Products please dispose them properly using an authorized industry waste company.

Precaution for Foreign Exchange and Foreign Trade act

Since our Products might fall under controlled goods prescribed by the applicable foreign exchange and foreign trade act, please consult with ROHM representative in case of export.

Precaution Regarding Intellectual Property Rights

1. All information and data including but not limited to application example contained in this document is for reference only. ROHM does not warrant that foregoing information or data will not infringe any intellectual property rights or any other rights of any third party regarding such information or data. ROHM shall not be in any way responsible or liable for infringement of any intellectual property rights or other damages arising from use of such information or data.:
2. No license, expressly or implied, is granted hereby under any intellectual property rights or other rights of ROHM or any third parties with respect to the information contained in this document.

Other Precaution

1. This document may not be reprinted or reproduced, in whole or in part, without prior written consent of ROHM.
2. The Products may not be disassembled, converted, modified, reproduced or otherwise changed without prior written consent of ROHM.
3. In no event shall you use in any way whatsoever the Products and the related technical information contained in the Products or this document for any military purposes, including but not limited to, the development of mass-destruction weapons.
4. The proper names of companies or products described in this document are trademarks or registered trademarks of ROHM, its affiliated companies or third parties.

General Precaution

1. Before you use our Products, you are requested to carefully read this document and fully understand its contents. ROHM shall not be in any way responsible or liable for failure, malfunction or accident arising from the use of any ROHM's Products against warning, caution or note contained in this document.
2. All information contained in this document is current as of the issuing date and subject to change without any prior notice. Before purchasing or using ROHM's Products, please confirm the latest information with a ROHM sales representative.
3. The information contained in this document is provided on an "as is" basis and ROHM does not warrant that all information contained in this document is accurate and/or error-free. ROHM shall not be in any way responsible or liable for any damages, expenses or losses incurred by you or third parties resulting from inaccuracy or errors of or concerning such information.