

NCP1083

Integrated High Power PoE-PD Interface & DC-DC Converter Controller with 9 V Auxiliary Supply Support

Introduction

The NCP1083 is a member of ON Semiconductor's high power HIPO Power over Ethernet Powered Device (PoE-PD) product family and represents a robust, flexible and highly integrated solution targeting demanding medium and high power Ethernet applications. It combines in a single unit an enhanced PoE-PD interface supporting the IEEE 802.3af and the 802.3at standard and a flexible and configurable DC-DC converter controller.

The NCP1083's exceptional capabilities enable applications to smoothly transition from non-PoE to PoE enabled networks by also supporting power from auxiliary sources such as AC power adapters and battery supplies, eliminating the need for a second switching power supply.

ON Semiconductor's unique manufacturing process and design enhancements allow the NCP1083 to deliver up to 25.5 W for the IEEE 802.3at standard and up to 40 W for proprietary high power PoE applications. The NCP1083 enables the IEEE 802.3at and implements a two event physical layer classification. Additional proprietary classification procedures support high power power sourcing equipment (PSE) on the market. The unique high power features leverage the significant cost advantages of PoE-enabled systems to a much broader spectrum of products in emerging markets such as industrial ethernet devices, PTZ and Dome IP cameras, RFID readers, MIMO WLAN access points, high-end VoIP phones, notebooks, etc.

The integrated current mode DC-DC controller facilitates isolated and non-isolated fly-back, forward and buck converter topologies. It has all the features necessary for a flexible, robust and highly efficient design including programmable switching frequency, duty cycle up to 80 percent, slope compensation, and soft start-up.

The NCP1083 is fabricated in a robust high voltage process and integrates a rugged vertical N-channel DMOS with a low loss current sense technique suitable for the most demanding environments and capable of withstanding harsh environments such as hot swap and cable ESD events.

The NCP1083 complements ON Semiconductor's ASSP portfolio in industrial devices and can be combined with stepper motor drivers, CAN bus drivers and other high-voltage interfacing devices to offer complete solutions to the industrial and security market.

Features

- These are Pb-Free Devices

Powered Device Interface

- Flexible Auxiliary Power Supply Support



ON Semiconductor®

<http://onsemi.com>

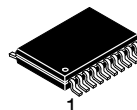

TSSOP-20 EP
DE SUFFIX
CASE 948AB

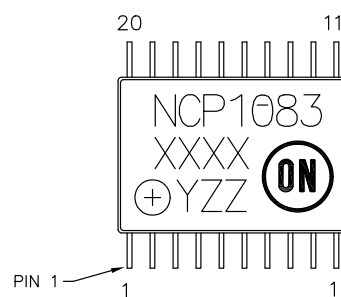

NCP1083 = Specific Device Code
XXXX = Date Code
Y = Assembly Location
ZZ = Traceability Code

ORDERING INFORMATION

See detailed ordering and shipping information in the package dimensions section on page 2 of this data sheet.

- 9 V Front, Rear and Direct Auxiliary Supply Connections
- Supporting the IEEE 802.3af and the 802.3at Standard
- Supports IEEE 802.3at Two Event Layer 1 Classification
- High Power Layer 1 Classification Indicator
- Extended Power Ranges up to 40 W
- Programmable Classification Current
- Adjustable Under Voltage Lock Out
- Programmable Inrush Current Limit
- Programmable Operational Current Limit up to 1100 mA for Extended Power Ranges
- Over-temperature Protection
- Industrial Temperature Range -40°C to 85°C with Full Operation up to 150°C Junction Temperature
- 0.6 Ω Hot-Swap Pass-switch with Low Loss Current Sense Technique
- Vertical N-channel DMOS Pass-switch Offers the Robustness of Discrete MOSFETs with Integrated Temperature Control

NCP1083

DC-DC Converter Controller

- Current Mode Control
- Supports Isolated and Non-isolated DC-DC Converter Applications
- Internal Voltage Regulators
- Wide Duty Cycle Range with Internal Slope Compensation Circuitry
- Programmable Oscillator Frequency
- Programmable Soft-start Time

PIN DIAGRAM

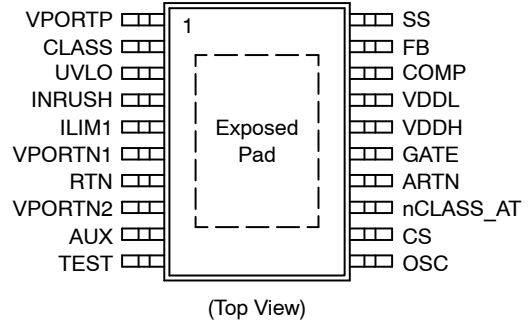

ORDERING INFORMATION

Part Number	Temperature Range	Package	Shipping Configuration†
NCP1083DEG	-40°C to 85°C	TSSOP-20 EP (Pb-Free)	74 units / Tube
NCP1083DER2G	-40°C to 85°C	TSSOP-20 EP (Pb-Free)	2500 / Tape & Reel

†For information on tape and reel specifications, including part orientation and tape sizes, please refer to our Tape and Reel Packaging Specification Brochure, BRD8011/D.

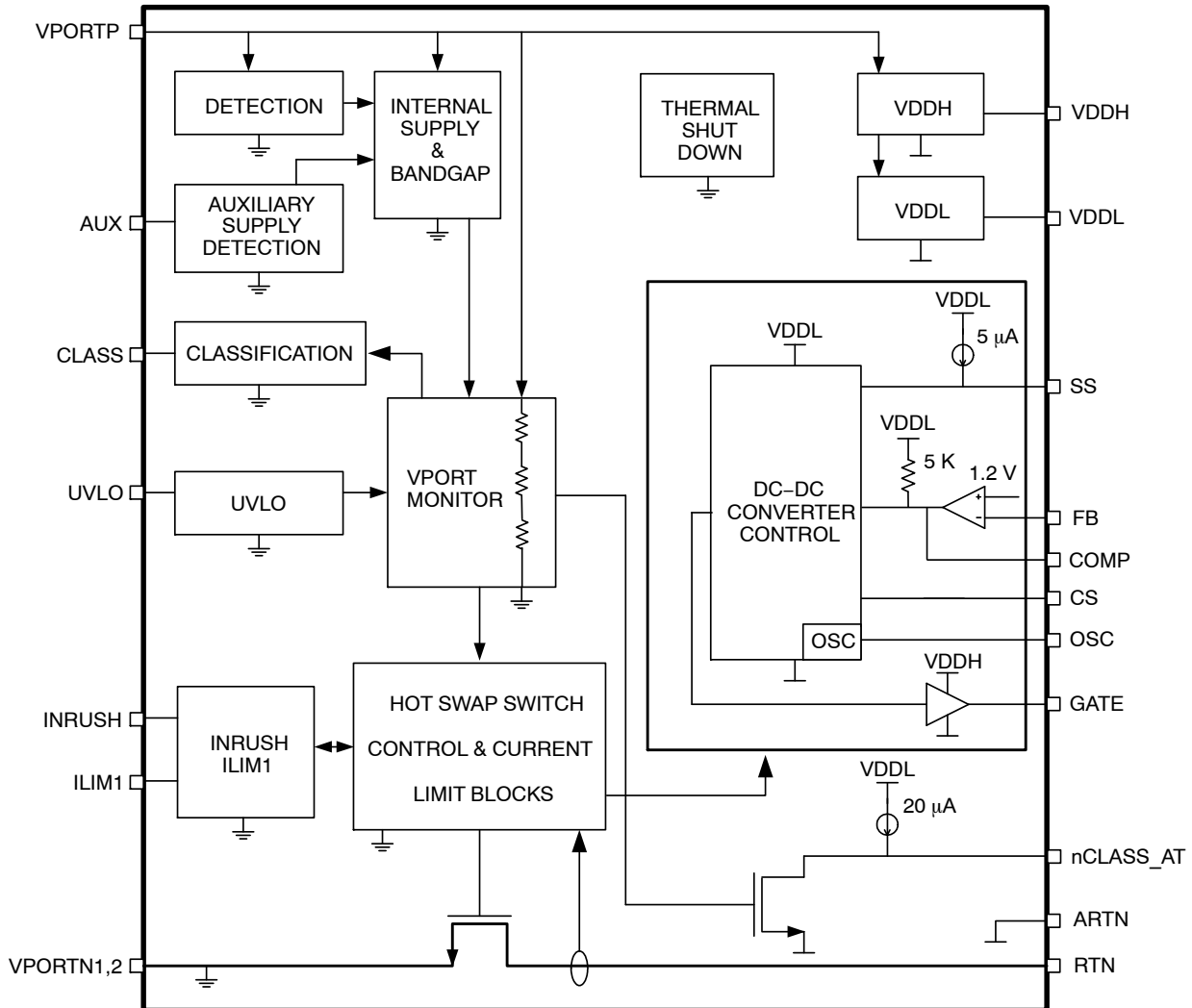

Figure 1. NCP1083 Block Diagram

NCP1083

SIMPLIFIED APPLICATION DIAGRAMS

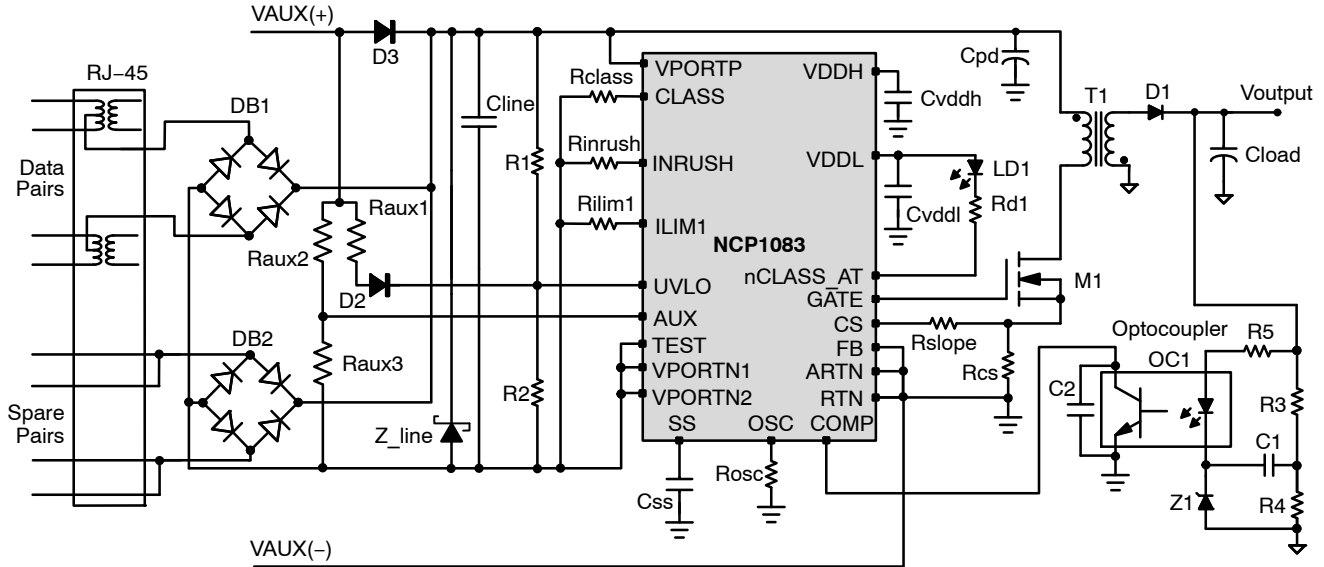

Figure 2. Isolated Fly-back Converter with Rear Auxiliary Supply

Figure 2 shows the integrated PoE-PD switch and DC-DC controller configured to work in a fully isolated application. The output voltage regulation is accomplished with an external opto-coupler and a shunt regulator (Z1).

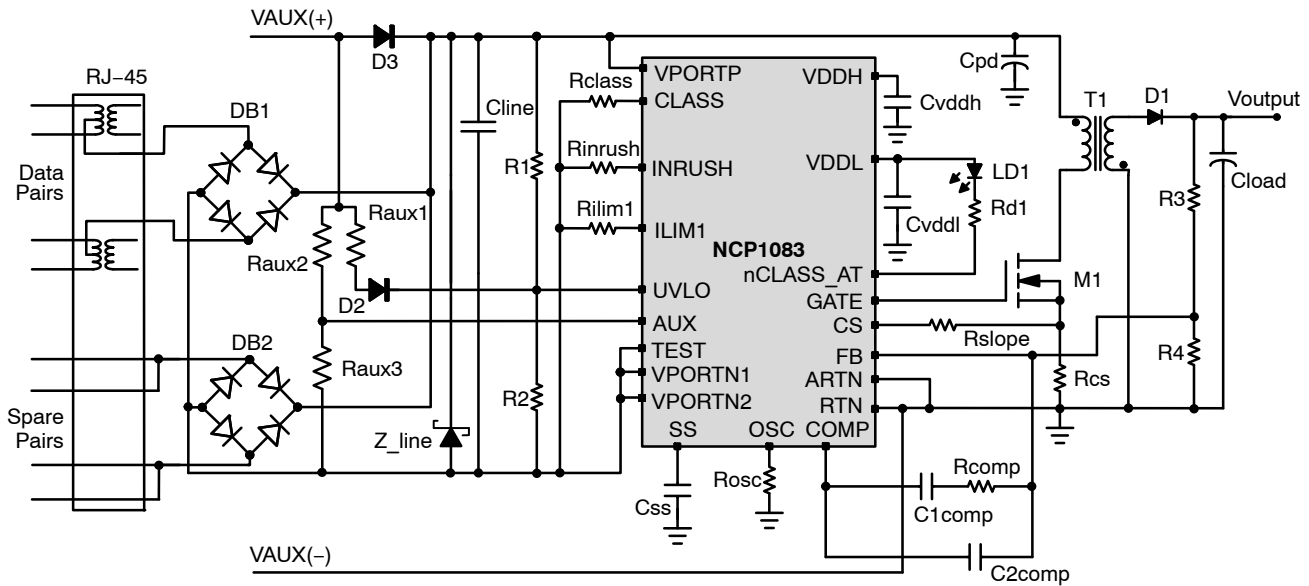

Figure 3. Non-Isolated Fly-back Converter with Rear Auxiliary Supply

Figure 3 shows the integrated PoE-PD and DC-DC controller configured in a non-isolated fly-back configuration. A compensation network is inserted between the FB and the COMP pin for overall stability of the feedback loop.

NCP1083

SIMPLIFIED APPLICATION DIAGRAMS

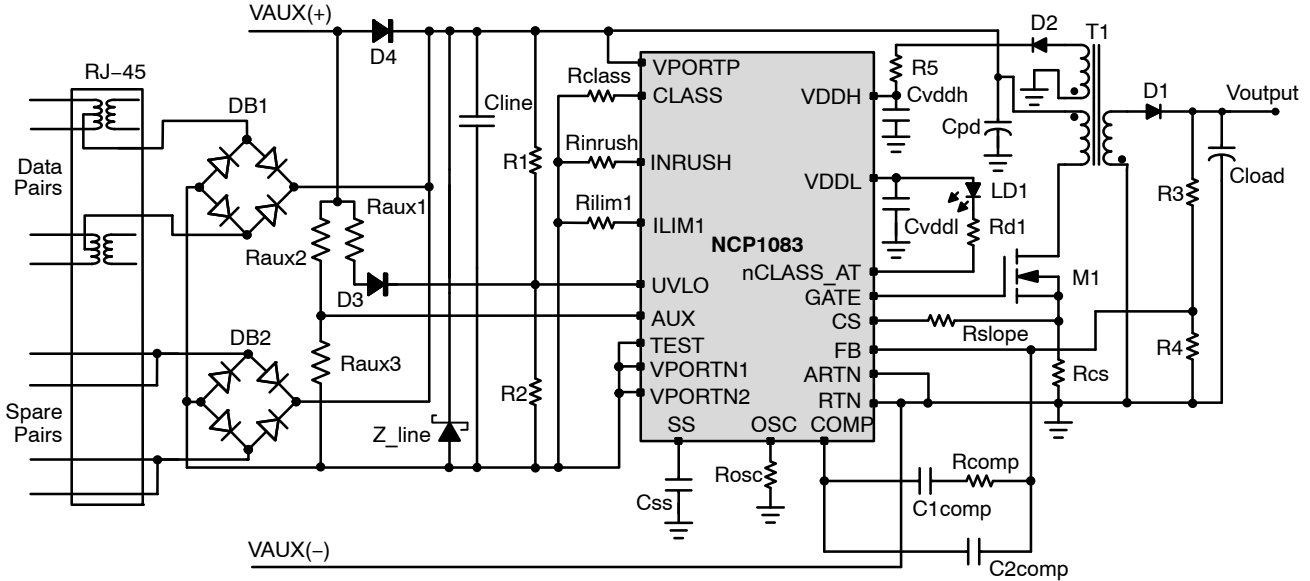

Figure 4. Non-Isolated Fly-back with Extra Winding and Rear Auxiliary Supply

Figure 4 shows the same non-isolated fly-back configuration as Figure 3, but adds a 12 V auxiliary bias winding on the transformer to provide power to the NCP1083 DC-DC controller via its VDDH pin. This topology shuts off the current flowing from VPORTP to VDDH and therefore reduces the internal power dissipation of the PD, resulting in higher overall power efficiency.

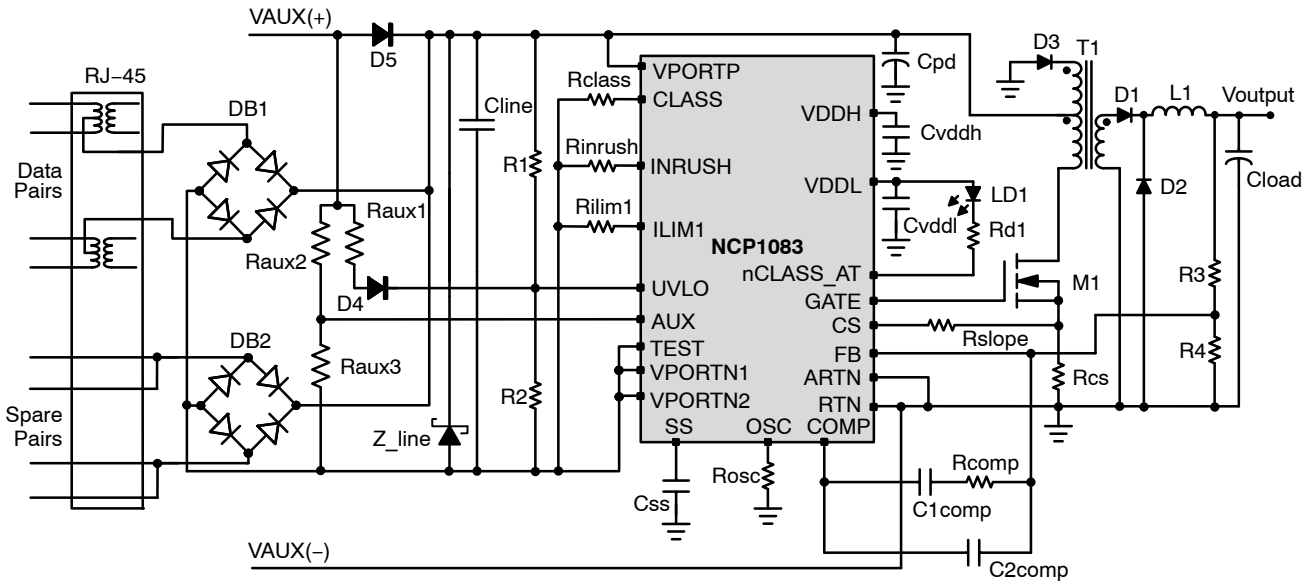

Figure 5. Non-Isolated Forward Converter with Rear Auxiliary Supply

Figure 5 shows the NCP1083 used in a non-isolated forward topology.

High Power Considerations

The NCP1083 is designed to implement various configurations of high-power PoE systems including those based on the IEEE 802.3at standard. High power operation can be enabled by a Dual Event Layer 1 classification or a Single Event Layer 1 classification combined with a Layer 2

high power classification. The NCP1083 also supports proprietary designs capable of delivering 25 W to 40 W to the load in two-pair configurations. A separate application note describes these implementations (AND8332).

NCP1083

Table 1. PIN DESCRIPTIONS

Name	Pin No.	Type	Description
VPORTP	1	Supply	Positive input power. Voltage with respect to VPORTN _{1,2} .
VPORTN1 VPORTN2	6,8	Ground	Negative input power. Connected to the source of the internal pass-switch.
RTN	7	Ground	DC-DC controller power return. Connected to the drain of the internal pass-switch. It must be connected to ARTN. This pin is also the drain of the internal pass-switch.
ARTN	14	Ground	DC-DC controller ground pin. Must be connected to RTN as a single point ground connection for improved noise immunity.
VDDH	16	Supply	Output of the 9 V LDO internal regulator. Voltage with respect to ARTN. Supplies the internal gate driver. VDDH must be bypassed to ARTN with a 1 μ F or 2.2 μ F ceramic capacitor with low ESR.
VDDL	17	Supply	Output of the 3.3 V LDO internal regulator. Voltage with respect to ARTN. This pin can be used to bias an external low-power LED (1 mA max.) connected to nCLASS_AT, and can also be used to add extra biasing current in the external opto-coupler. VDDL must be bypassed to ARTN with a 330 nF or 470 nF ceramic capacitor with low ESR.
CLASS	2	Input	Classification current programming pin. Connect a resistor between CLASS and VPORTN _{1,2} .
INRUSH	4	Input	Inrush current limit programming pin. Connect a resistor between INRUSH and VPORTN _{1,2} .
ILIM1	5	Input	Operational current limit programming pin. Connect a resistor between ILIM1 and VPORTN _{1,2} .
UVLO	3	Input	DC-DC controller under-voltage lockout input. Voltage with respect to VPORTN _{1,2} . Connect a resistor-divider from VPORTP to UVLO to VPORTN _{1,2} to set an external UVLO threshold.
GATE	15	Output	DC-DC controller gate driver output pin.
OSC	11	Input	Internal oscillator frequency programming pin. Connect a resistor between OSC and ARTN.
nCLASS_AT	13	Output, Open Drain	Active-low, open-drain Layer 1 dual-finger classification indicator.
COMP	18	I/O	Output of the internal error amplifier of the DC-DC controller. COMP is pulled-up internally to VDDL with a 5 k Ω resistor. In isolated applications, COMP is connected to the collector of the opto-coupler. Voltage with respect to ARTN.
FB	19	Input	DC-DC controller inverting input of the internal error amplifier. In isolated applications, the pin should be strapped to ARTN to disable the internal error amplifier.
CS	12	Input	Current-sense input for the DC-DC controller. Voltage with respect to ARTN.
SS	20	Input	Soft-start input for the DC-DC controller. A capacitor between SS and ARTN determines the soft-start timing.
AUX	9	Input	When the pin is pulled up, the IEEE detection mode is disabled and the device can be supplied by an auxiliary supply. Voltage with respect to VPORTN _{1,2} . Connect the pin to the auxiliary supply through a resistor divider.
TEST	10	Input	Digital test pin must always be connected to VPORTN _{1,2} .
EP			Exposed pad. Connected to VPORTN _{1,2} ground.

NCP1083

Table 2. ABSOLUTE MAXIMUM RATINGS

Symbol	Parameter	Conditions	Min	Max	Unit
VPORTP	Input power supply	Voltage with respect to VPORTN _{1,2}	-0.3	72	V
RTN ARTN	Analog ground supply 2	Pass-switch in off-state (Voltage with respect to VPORTN _{1,2})	-0.3	72	V
VDDH	Internal regulator output	Voltage with respect to ARTN	-0.3	17	V
VDDL	Internal regulator output	Voltage with respect to ARTN	-0.3	3.6	V
CLASS	Analog output	Voltage with respect to VPORTN _{1,2}	-0.3	3.6	V
INRUSH	Analog output	Voltage with respect to VPORTN _{1,2}	-0.3	3.6	V
ILIM1	Analog output	Voltage with respect to VPORTN _{1,2}	-0.3	3.6	V
UVLO	Analog input	Voltage with respect to VPORTN _{1,2}	-0.3	3.6	V
OSC	Analog output	Voltage with respect to ARTN	-0.3	3.6	V
COMP	Analog input / output	Voltage with respect to ARTN	-0.3	3.6	V
FB	Analog input	Voltage with respect to ARTN	-0.3	3.6	V
CS	Analog input	Voltage with respect to ARTN	-0.3	3.6	V
SS	Analog input	Voltage with respect to ARTN	-0.3	3.6	V
nCLASS_AT	Analog output	Voltage with respect to ARTN	-0.3	3.6	
AUX	Analog input	Voltage with respect to VPORTN _{1,2}	-0.3	3.6	V
TEST	Digital input	Voltage with respect to VPORTN _{1,2}	-0.3	3.6	V
T _a	Ambient temperature		-40	85	°C
T _j	Junction temperature		-	150	°C
T _j -TSD	Junction temperature (Note 1)	Thermal shutdown condition	-	175	°C
T _{stg}	Storage Temperature		-55	150	°C
T _{θJA}	Thermal Resistance, Junction to Air (Note 2)	Exposed pad connected to VPORTN _{1,2} ground		37.6	°C/W
ESD-HBM	Human Body Model	per JEDEC Standard JESD22	4	-	kV
ESD-CDM	Charged Device Model		750	-	V
ESD-MM	Machine Model		300	-	V
LU	Latch-up	per JEDEC Standard JESD78	±200	-	mA
ESD-SYS	System ESD (contact/air) (Note 3)		8/15	-	kV

Stresses exceeding Maximum Ratings may damage the device. Maximum Ratings are stress ratings only. Functional operation above the Recommended Operating Conditions is not implied. Extended exposure to stresses above the Recommended Operating Conditions may affect device reliability.

1. T_j-TSD allowed during error conditions only. It is assumed that this maximum temperature condition does not occur more than 1 hour cumulative during the useful life for reliability reasons.
2. Mounted on a 1S2P (3 layer) test board with copper coverage of 25 percent for the signal layers and 90 percent copper coverage for the inner planes at an ambient temperature of 85°C in still air. Refer to JEDEC JESD51-7 for details.
3. Surges per EN61000-4-2, 1999 applied between RJ-45 and output ground and between adapter input and output ground of the evaluation board. The specified values are the test levels and not the failure levels.

Recommended Operating Conditions

Operating conditions define the limits for functional operation and parametric characteristics of the device. Note that the functionality of the device outside the operating conditions described in this section is not warranted. Operating outside the recommended operating conditions for extended periods of time may affect device reliability.

All values concerning the DC-DC controller, VDDH, VDDL, and nCLASS_AT blocks are with respect to ARTN. All others are with respect to VPORTN_{1,2} (unless otherwise noted).

Table 3. OPERATING CONDITIONS

Symbol	Parameter	Conditions	Min	Typ	Max	Unit
INPUT SUPPLY						
VPORT	Input supply voltage	VPORT = VPORTP – VPORTN _{1,2}	0		57	V

SIGNATURE DETECTION

Vsignature	Input supply voltage signature detection range		1.4		9.5	V
Rsignature	Signature resistance (Note 4)		23.75		26.25	kΩ
Offset_current	I_VportP + I_Rtn	VPORTP = RTN = 1.4 V	–	1.8	5	μA
Sleep_current	I_VportP + I_Rtn	VPORTP = RTN = 9.5 V	–	15	25	μA

CLASSIFICATION

Vcl	Input supply voltage classification range		13		20.5	V
V_mark	Mark event voltage range (VPORTP falling)		5.4	–	9.7	V
I_mark	Current consumption I_VportP + I_Rdet in Mark Event range	5.4 V ≤ VPORT ≤ 9.5 V	0.5	–	2.0	mA
dR_mark	Input signature during Mark Event (Note 7)	For information only	–	–	12	kΩ
Vreset	Classification Reset range (VPORTP falling)		4.3	4.9	5.4	V
Iclass0	Class 0: Rclass 10 kΩ (Note 6)	Iclass0 = I_VportP + I_Rdet	0	–	4	mA
Iclass1	Class 1: Rclass 130 Ω (Note 6)	Iclass1 = I_VportP + I_Rdet	9	–	12	mA
Iclass2	Class 2: Rclass 69.8 Ω (Note 6)	Iclass2 = I_VportP + I_Rdet	17	–	20	mA
Iclass3	Class 3: Rclass 44.2 Ω (Note 6)	Iclass3 = I_VportP + I_Rdet	26	–	30	mA
Iclass4	Class 4: Rclass 30.9 Ω (Note 6)	Iclass4 = I_VportP + I_Rdet	36	–	44	mA
Iclass5	Class 5: Rclass 22.1 Ω (Notes 5 and 6) (for proprietary high power applications)	Iclass5 = I_VportP + I_Rdet	50	–	60	mA
IDC _{class}	Internal current consumption during classification (Note 8)	For information only	–	600	–	μA

CLASSIFICATION INDICATOR

nCLASS_AT_i	nCLASS_AT current source		13	20	27	μA
NCLASS_AT_pd	R _{DS,ON} of NCLASS_AT pull down transistor	For information only		130		Ω

4. Test done according to the IEEE 802.3af 2 Point Measurement. The minimum probe voltages measured at the PoE-PD are 1.4 V and 2.4 V, and the maximum probe voltages are 8.5 V and 9.5 V.
5. This extended classification range can be used with a PSE which also uses this classification range to deliver more current than specified by IEEE 802.3.
6. Measured with an external Rdet of 25.5 kΩ between VPORTP and VPORTN_{1,2}, and for 13 V < VPORT < 20.5 V (with VPORT = VPORTP – VPORTN_{1,2}). Resistors are assumed to have 1% accuracy.
7. Measured with the 2 Point Measurement defined in the IEEE 802.3af standard with 5.4 V and 9.5 V the extreme values for V2 and V1.
8. This typical current excludes the current in the Rclass and Rdet external resistors.

Table 3. OPERATING CONDITIONS

Symbol	Parameter	Conditions	Min	Typ	Max	Unit
UVLO						
Vuvlo_on	Default turn on voltage (VportP rising)	UVLO pin tied to VPORTN _{1,2}	–	38	40	V
Vuvlo_off	Default turn off voltage (VportP falling)	UVLO pin tied to VPORTN _{1,2}	29.5	32	–	V
Vhyst_int	UVLO internal hysteresis	UVLO pin tied to VPORTN _{1,2}	–	6	–	V
Vuvlo_pr	UVLO external programming range	UVLO pin connected to the resistor divider (R1 & R2). AUX pin tied to VPORTN _{1,2} For information only	13	–	50	V
Vuvlo_pr_aux	UVLO external programming VPORT range with auxiliary supply support	UVLO & AUX pins configured for auxiliary supply support	8.5	–	18	V
Vhyst_ext	UVLO external hysteresis	UVLO pin connected to the resistor divider (R1 & R2)	–	15	–	%
Uvlo_Filter	UVLO on/off filter time	For information only	–	90	–	μS

AUXILIARY SUPPLY OPERATION – INPUT SUPPLY

Vaux_min1	VPORTP–ARTN voltage at startup (required for VDDH > VDDH_Por_R)	VAUX rising – No external load on VDDL & VDDH	8.7	–	–	V
Vaux_min2	VPORTP–ARTN voltage during PWM operation (required for VDDH > VDDH_Por_F)	Voltage with respect to Ivddl_load1 & Ivddh_load1 for the load current conditions	8.5	–	–	V

AUXILIARY SUPPLY OPERATION – AUX PIN

Vaux_off	Voltage range of the AUX pin where the auxiliary supply circuit is guaranteed not operational.	Voltage with respect to VPORTN _{1,2} .	–	–	0.2	V
Vaux_on	Voltage range of the AUX pin where the auxiliary supply circuit is guaranteed operational.	Voltage with respect to VPORTN _{1,2}	1.5	–	3.3	V
Raux	Total resistance value of the resistor divider connected to the AUX pin (sum of R _{aux1} and R _{aux3})	Between VAUX supply & VPORTN _{1,2}	–	–	25	kΩ

AUXILIARY SUPPLY OPERATION – VDDL REGULATOR

Ivddl_load1	Current load on the VDDL pin with VPORTP – ARTN = 8.5 V (Notes 9 and 10)	Ivddh_load + Ivddl_load < 4.5 mA	–	–	1	mA
Ivddl_load2	Current load on the VDDL pin with VPORTP – ARTN > 12.5 V (Notes 9 and 10)	Ivddh_load + Ivddl_load < 10 mA	–	–	2.25	mA

AUXILIARY SUPPLY OPERATION – VDDH REGULATOR

Ivddh_load1	Current load on the VDDH regulator with VPORTP – ARTN = 8.5 V (Notes 9 and 10)	Ivddh_load + Ivddl_load < 4.5 mA	–	–	4.5	mA
Ivddh_load2	Current load on the VDDH regulator with VPORTP – ARTN > 12.5 V (Notes 9 and 10)	Ivddh_load + Ivddl_load < 10 mA	–	–	10	mA

9. Ivddl_load = current flowing out of the VDDL pin.

Ivddh_load = current flowing out of the VDDH pin + current delivered to the Gate Driver (function of the frequency, VDDH voltage & MOSFET gate capacitance).

10. See Figures 6 and 7 for specifications on the load current at lower or higher VPORTP - ARTN voltages. In case the application requires more current capability on VDDL and VDDH, it is recommended to externally supply the VDDH pin with a bias winding from the transformer or to add a diode between VAUX(+) and VDDH pin (verify the VAUX voltage does not exceed the VDDH voltage range).

NCP1083

Table 3. OPERATING CONDITIONS

Symbol	Parameter	Conditions	Min	Typ	Max	Unit
PASS-SWITCH AND CURRENT LIMITS						
Ron	Pass-switch Rds-on	Max Ron specified at Tj = 130°C	-	0.6	1.2	Ω
I_Rinrush1	Rinrush = 150 kΩ (Note 11)	Measured at RTN-VPORTN _{1,2} = 3 V	95	125	155	mA
I_Rinrush2	Rinrush = 57.6 kΩ (Note 11)	Measured at RTN-VPORTN _{1,2} = 3 V	260	310	360	mA
I_Rilim1	Rilim1 = 84.5 kΩ (Note 11)	Current limit threshold	450	510	570	mA
I_Rilim2	Rilim1 = 66.5 kΩ (Note 11)	Current limit threshold	600	645	690	mA
I_Rilim3	Rilim1 = 55.6 kΩ (Note 11)	Current limit threshold	720	770	820	mA
I_Rilim4	Rilim1 = 38.3 kΩ (Note 11)	Current limit threshold	970	1100	1230	mA
INRUSH AND ILIM1 CURRENT LIMIT TRANSITION						
Vds_pgood	VDS required for power good status	RTN-VPORTN _{1,2} falling; voltage with respect to VPORTN _{1,2}	0.8	1	1.2	V
Vds_pgood_hyst	VDS hysteresis required for power good status	Voltage with respect to VPORTN _{1,2}	-	8.2	-	V
VDDH REGULATOR						
VDDH_reg	Regulator output voltage (Notes 12 and 13)	lvddh_load + lvddl_load < 10 mA with lvddl_load < 2.25 mA and 12.5 V < VPORTP - ARTN < 57 V	8.4	9	9.6	V
VDDH_Off	Regulator turn-off voltage	For information only	VDDH_reg + 0.5 V			V
VDDH_lim	VDDH regulator current limit (Notes 12 and 13)		13	-	26	mA
VDDH_Por_R	VDDH POR level (rising)		7.3	-	8.3	V
VDDH_Por_F	VDDH POR level (falling)		6	-	7	V
VDDH_ovlo	VDDH over-voltage level (rising)		16	-	18.5	V
VDDL REGULATOR						
VDDL_reg	Regulator output voltage (Notes 12 and 13)	lvddl_load < 2.25 mA with lvddh_load + lvddl_load < 10 mA and 12.5 V < VPORTP - ARTN < 57 V	3.05	3.3	3.55	V
VDDL_Por_R	VDDL POR level (rising)		VDDL - 0.2	-	VDDL - 0.02	V
VDDL_Por_F	VDDL POR level (falling)		2.5	-	2.9	V
GATE DRIVER						
Gate_Tr	GATE rise time (10-90%)	Clod = 2 nF, VDDHreg = 9 V	-	-	50	ns
Gate_Tf	GATE fall time (90-10%)	Clod = 2 nF, VDDHreg = 9 V	-	-	50	ns
PWM COMPARATOR						
VCOMP	COMP control voltage range	For information only	1.3	-	3	V
ERROR AMPLIFIER						
Vbg_fb	Reference voltage	Voltage with respect to ARTN	1.15	1.2	1.25	V
Av_ol	DC open loop gain	For information only	-	80	-	dB
GBW	Error amplifier GBW	For information only	1	-	-	MHz

11. The current value corresponds to the PoE-PD input current (the current flowing in the external Rdet and the quiescent current of the device are included). Resistors are assumed to have 1% accuracy.
12. Power dissipation must be considered. Load on VDDH and VDDL must be limited especially if VDDH is not powered by an auxiliary winding.
13. lvddl_load = current flowing out of the VDDL pin.
 lvddh_load = current flowing out of the VDDH pin + current delivered to the Gate Driver (function of the frequency, VDDH voltage & MOSFET gate capacitance).

Table 3. OPERATING CONDITIONS

Symbol	Parameter	Conditions	Min	Typ	Max	Unit
SOFT-START						
V _{ss}	Soft-start voltage range		-	1.15	-	V
V _{ss_r}	Soft-start low threshold (rising edge)		0.35	0.45	0.55	V
I _{ss}	Soft-start source current		3	5	7	μA
CURRENT LIMIT COMPARATOR						
CSt _h	CS threshold voltage		324	360	396	mV
T _{blank}	Blanking time	For information only	-	100	-	ns
OSCILLATOR						
DutyC	Maximum duty cycle	Fixed internally	-	80%	-	
F _{range}	Oscillator frequency range		100	-	500	kHz
F _{acc}	Oscillator frequency accuracy			±25		%
CURRENT CONSUMPTION						
I _{vportP₁}	VPORTP internal current consumption (Note 14)	DC-DC controller off	-	2.5	3.5	mA
I _{vportP₂}	VPORTP internal current consumption (Note 15)	DC-DC controller on	-	4.7	6.5	mA
THERMAL SHUTDOWN						
TSD	Thermal shutdown threshold	T _j = junction temperature	150	-	-	°C T _j
Thyst	Thermal hysteresis	T _j = junction temperature	-	15	-	°C T _j
THERMAL RATINGS						
T _A	Ambient temperature		-40	-	85	°C
T _J	Junction temperature	Parametric values guaranteed - Max 1000 hours	-	-	125 150	°C °C

14. Conditions

- a. No current through the pass-switch
- b. DC-DC controller inactive (SS shorted to RTN)
- c. No external load on VDDH and VDDL
- d. VPORTP = 57 V

15. Conditions

- a. No current through the pass-switch
- b. Oscillator frequency = 100 kHz
- c. No external load on VDDH and VDDL
- d. Aux winding not used
- e. 2 nF on GATE, DC-DC controller enabled
- f. VPORTP = 57 V

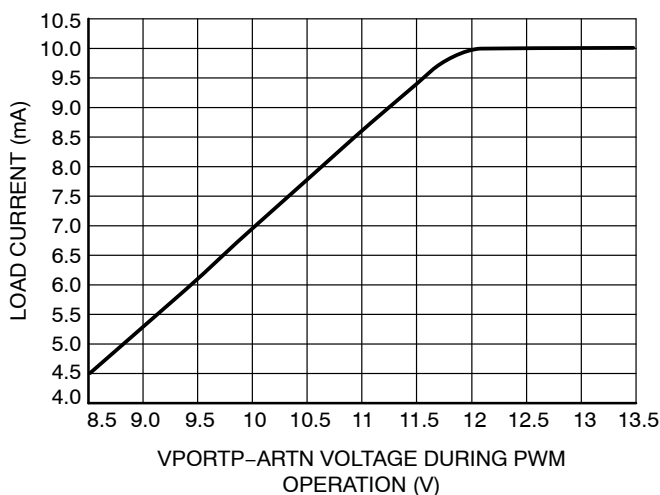

Figure 6. (I_{vddl_load})_{max} with Auxiliary Supply Operation

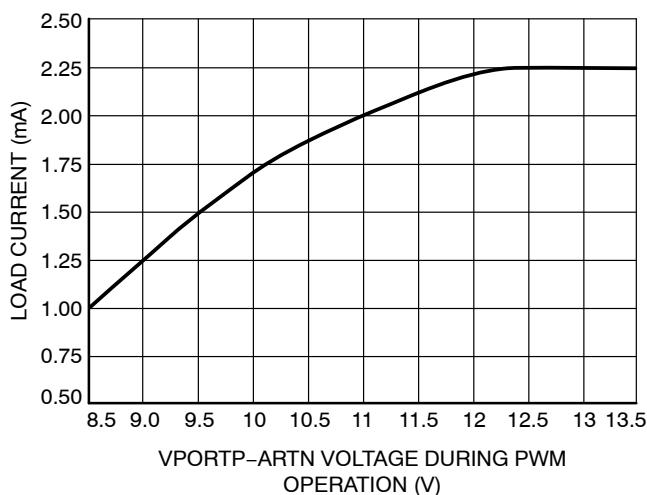

Figure 7. (I_{vddh_load}+I_{vddl_load})_{max} with Auxiliary Supply Operation

Description of Operation

Powered Device Interface

The PD interface portion of the NCP1083 supports the IEEE 802.3af and 802.3at defined operating modes: detection signature, current source classification, inrush and operating current limits. In order to give more flexibility to the user and also to keep control of the power dissipation in the NCP1083, both current limits are configurable. The device enters operation once its programmable Vuvlo_on threshold is reached, and operation ceases when the supplied voltage falls below the Vuvlo_off threshold. Sufficient hysteresis and Uvlo filter time are provided to avoid false power on/off cycles due to transient voltage drops on the cable.

Detection

During the detection phase, the incremental equivalent resistance seen by the PSE through the cable must be in the IEEE 802.3af standard specification range (23.75 kΩ to 26.25 kΩ) for a PSE voltage from 2.7 V to 10.1 V. In order to compensate for the non-linear effect of the diode bridge and satisfy the specification at low PSE voltage, the NCP1083 presents suitable impedance in parallel with the 25.5 kΩ R_{det} external resistor connected between VPORTP and VPORNTN. For some types of diodes (especially Schottky diodes), it may be necessary to adjust this external resistor.

When the Detection_Off level is detected (typically 11.5 V) on VPORTP, the NCP1083 turns on its internal 3.3 V regulator and biasing circuitry in anticipation of the classification phase as the next step.

Classification

Once the PSE device has detected the PD device, the classification process begins. The NCP1083 is fully capable of responding and completing all classification handshaking procedures as described next.

Classification Current Source Generation

In classification, the PD regulates a constant current source that is set by the external resistor RCLASS value on the CLASS pin. Figure 8 shows the schematic overview of the classification block. The current source is defined as:

$$I_{class} = \frac{V_{bg}}{R_{class}}, \text{ (where } V_{bg} \text{ is 1.2 V)}$$

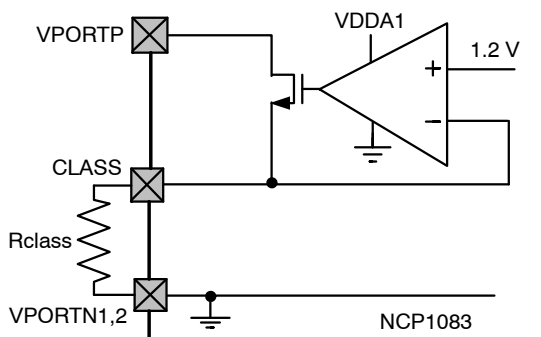

Figure 8. Classification Block Diagram

The NCP1083 can handle all defined types of classification, IEEE 802.3af, 802.3at and proprietary classification.

In the IEEE 802.3af standard the classification is performed with a Single Event Layer 1 classification. Depending on the current level set during that single event the power level is determined. The IEEE 802.3at standard allows two ways of classification which can also be combined. These two approaches enable higher power applications through a variety of PSE equipment.

For power injectors and midspans a pure physical hardware handshake is introduced called Two Event Layer 1 classification. This approach allows equipment that has no data link between PSE and PD to classify as high power.

Since switches can establish a data link between PSE and PD, a software handshake is possible. This type of handshake is called Layer 2 classification (or Data Link Layer classification). It has the main advantage of having a finer power resolution and the ability for the PSE and PD to participate in dynamic power allocation.

Table 4. SINGLE AND DUAL EVENT CLASSIFICATION

Standard	Layer	Handshake
802.3af	1	Single event physical classification
802.3at	1	Two event physical classification
802.3at	2	Data-link (IP) communication classification

One Event Layer 1 Classification

An IEEE 802.3af compliant PSE performs only One Event Layer 1 classification event by increasing the line voltage into the classification range only once.

Two Event Layer 1 Classification

A IEEE 802.3at compliant PSE using this physical classification performs two classification events and looks for the appropriate response from the PD to check if the PD is IEEE 802.3at compatible.

The PSE will generate the sequence described in Figure 8. During the first classification finger, the PSE will measure the classification current which should be 40 mA if the PD is at compliant. If this is the case, the PSE will exit the classification range and will force the line voltage into the Mark Event range. Within this range, the PSE may check the non-valid input signature presented by the PD (using the two point measurement defined in the IEEE 802.3af standard). Then the PSE will repeat the same sequence with the second classification finger. A PD which has detected the sequence “*Finger + Mark + Finger + Mark*” knows the PSE is IEEE 802.3at compliant, meaning the PSE will deliver more current on the port. (Note that a PSE IEEE 802.3at compliant may apply more than two fingers, but the final result will be the same as two fingers).

NCP1083

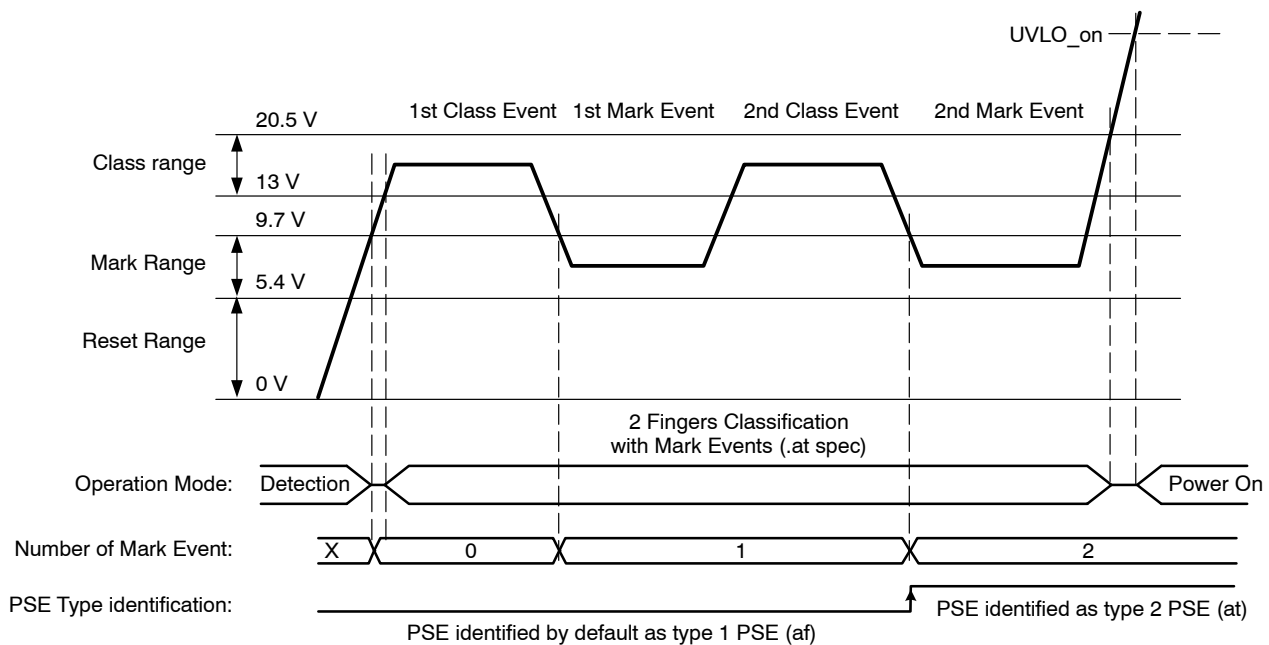

Figure 9. Hardware Physical Classification Event Sequence

nCLASS_AT Indicator

The nCLASS_AT active low open drain output pin can be used to notify to the microprocessor of the powered device that the PSE performed a one or two event hardware classification. If a two event hardware classification has occurred and once the PD application is supplied power by the NCP1083 DC-DC converter, the nCLASS_AT pin will be pulled down to ARTN by the internal low voltage NMOS switch (ARTN is the ground connection of the DC-DC

converter). Otherwise, nCLASS_AT will be disabled and will be pulled up to VDDL (3.3 V typ) via an internal current source (20 μ A typ) and via the external pull-up resistor.

The following scheme illustrates how the nCLASS_AT pin may be configured with the processor of the powered device. An opto-coupler is used to guarantee full isolation between the Ethernet cable and the application.

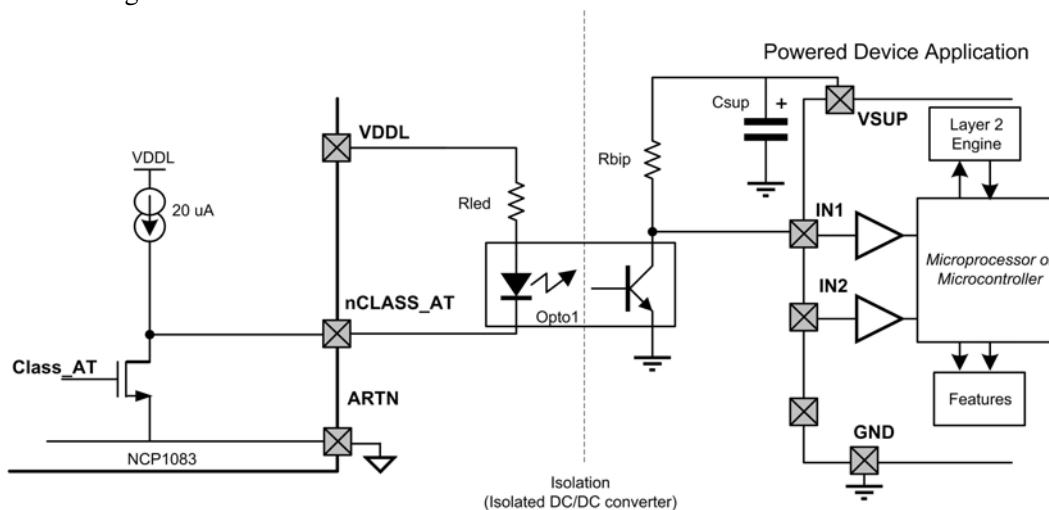

Figure 10. Isolated nClass_AT Communication with the Powered Device Application

As soon as the application is powered by the DC-DC converter and completes initialization, the microprocessor should check if the NCP1083 detected a two event hardware classification by reading its digital input (pin IN1 in this example). If pin IN1 is low, the application knows power is

supplied by a IEEE 802.3at compliant PSE, and can deliver power up to the level specified by the IEEE 802.3at standard.

Otherwise the application will have to perform a Layer 2 classification with the PSE. There are several scenarios for which the NCP1083 will not enable its nCLASS_AT pin:

- The PSE skipped the classification phase.
- The PSE performed a one event hardware classification (it can be a IEEE 802.3af or a 802.3at compliant PSE with Layer 2 engine).
- The PSE performed a two event hardware classification but it did not properly control the input voltage in the mark voltage window, (for example it crossed the reset range).

Power Mode

When the classification hand–shake is completed, the PSE and PD devices move into the operating mode.

Under Voltage Lock Out (UVLO)

The NCP1083 incorporates an under voltage lock out (UVLO) circuit which monitors the input voltage and determines when to apply power to the DC–DC controller.

To use the default settings for UVLO (see Table 3), the pin UVLO must be connected to VPORNT_{1,2}. In this case the signature resistor has to be placed directly between VPORTP and VPORNT_{1,2}, as shown in Figure 11.

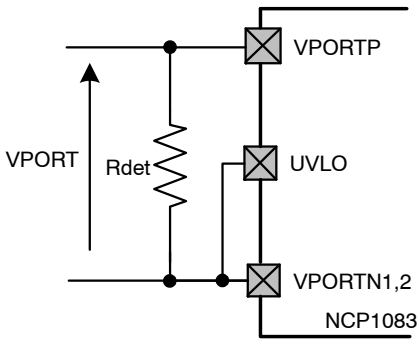

Figure 11. Default UVLO Settings

To define the UVLO threshold externally, the UVLO pin must be connected to the center of an external resistor divider between VPORTP and VPORNT_{1,2} as shown in Figure 12. The series resistance value of the external

resistors must add to 25.5 kΩ and replaces the internal signature resistor.

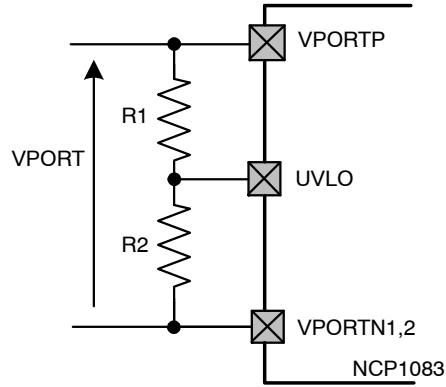

Figure 12. External UVLO Configuration

For a V_{ulvo_on} desired turn–on voltage threshold, R1 and R2 can be calculated using the following equations:

$$R1 + R2 = R_{det}$$

$$R2 = \frac{1.2}{V_{ulvo_on}} \times R_{det}$$

When using the external resistor divider, the NCP1083 has an external reference voltage hysteresis of 15 percent typical.

Auxiliary Supply Support

To support applications connected to non–PoE enabled networks and minimize the bill of materials, the NCP1083 supports drawing power from an external supply. The NCP1083 supports the IEEE 802.3af/at standard when PoE power sourcing is available and acts as a regular DC–DC converter when there is no power source available on the Ethernet cable as shown in Figure 13.

Auxiliary supply support can be implemented in three ways depending on where the auxiliary supply is injected. The front, rear and direct auxiliary supply configurations are explained in more detail in the application note AND9080.

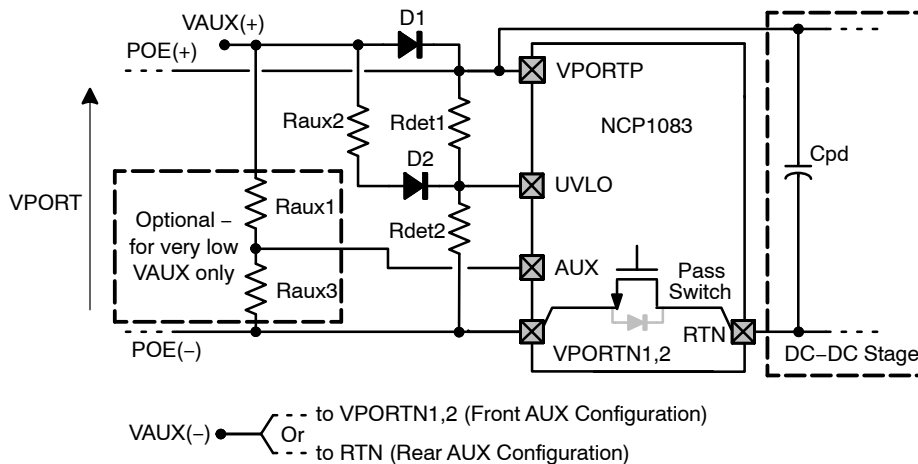

Figure 13. Front and Rear Auxiliary Supply Input with Support for Very Low Input Voltages

NCP1083

When the auxiliary input supply is above 13.5 V, connect the AUX pin to VPORTN_{1,2}. When the auxiliary supply is below 13.5 V (but above 9 V), calculate the voltage dividers R_{aux1}, R_{aux3} and R_{aux2}, R_{det1}, R_{det2} to divide the input voltage using the below formulas together with the formulas from the previous section. This will ensure that for valid input voltages, the voltage at the UVLO and AUX pins are above their threshold voltages. Note that the maximum voltage is 3.3 V.

$$R_{aux3} = \frac{R_{aux1} \times V_t}{V_{aux} - V_{dp} - V_t}$$

$$R_{aux2} = \frac{V_{aux} - V_{dp} - V_d - V_t}{\frac{V_t}{845} - \frac{V_{aux} - V_{dp} - V_d - V_t}{24 K}}$$

$$R_{aux1} = 20 \text{ k}\Omega$$

Where V_d is the voltage drop over the rectifiers and masking diodes (typical 0.6 V), V_{dp} is the forward drop of the

NCP1083 internal diode (typical 0.5 V), and V_t is the threshold voltage on the AUX pin (typical 1.5 V).

Note that as soon as the auxiliary supply is connected the PoE interface (detection and classification) is disabled and does not allow the PD device to be powered from the Ethernet until the auxiliary supply is removed.

If the PoE PD device was drawing the current from the Ethernet cable before the auxiliary supply is connected, the power will continue to be supplied from the Ethernet cable unless the voltage of the auxiliary supply is higher than the Ethernet supply voltage.

Inrush and Operational Current Limitations

The inrush current limit and the operational current limit are programmed individually by an external Rinrush and Rlim1 resistors respectively connected between ILIM1 and VPORTN_{1,2}, and between ILIM1 and VPORTN_{1,2} as shown in Figure 14.

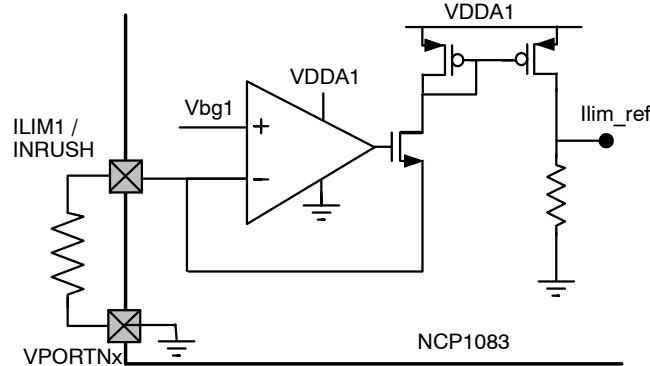

Figure 14. Current Limitation Configuration (Inrush & Ilim1 Pins)

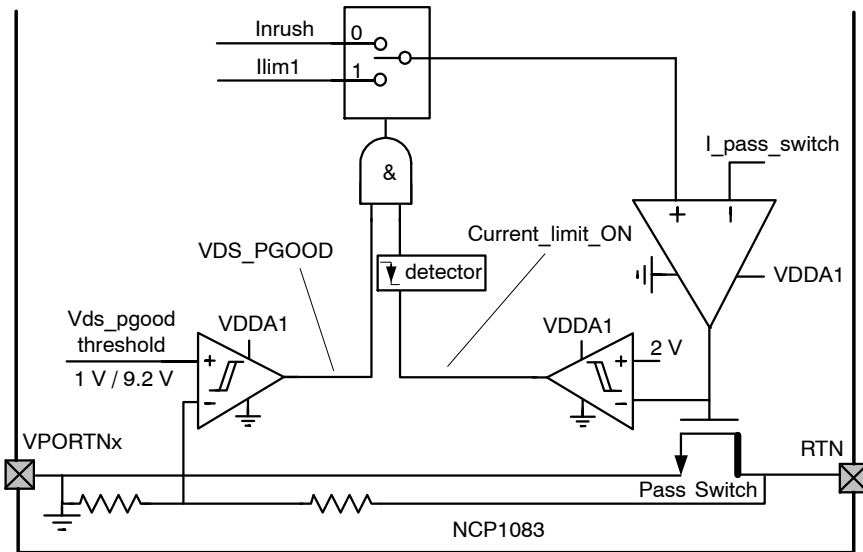

Figure 15. Inrush and Ilim1 Selection Mechanism

When VPORT reaches the UVLO_on level, the Cpd capacitor is charged with the INRUSH current (in order to limit the internal power dissipation of the pass-switch). Once the Cpd capacitor is fully charged, the current limit switches from the inrush current to the current level (ilim1) as shown in Figure 15. This transition occurs when both following conditions are satisfied:

1. The VDS of the pass-switch is below the Vds_pgood low level (1 V typical).
2. The pass-switch is no longer in current limit mode, meaning the gate of the pass-switch is “high” (above 2 V typical).

The operational current limit will stay selected as long as Vds_pgood is true (meaning that RTN-VPORTN_{1,2} is below the high level of Vds_pgood). This mechanism allows a current level transition without any current spike in the pass-switch because the operational current limit (ilim1) is enabled once the pass-switch is not limiting the current anymore, meaning that the Cpd capacitor is fully charged.

Thermal Shutdown

The NCP1083 includes thermal protection which shuts down the device in case of high power dissipation. Once the thermal shutdown (TSD) threshold is exceeded, following blocks are turned off:

- DC-DC controller
- Pass-switch
- VDDH and VDDL regulators
- CLASS regulator

When the TSD error disappears and if the input line voltage is still above the UVLO level, the NCP1083 automatically restarts with the current limit set in the inrush state, the DC-DC controller is disabled and the C_{ss} (soft-start capacitor) discharged. The DC-DC controller becomes operational as soon as capacitor Cpd is fully charged.

DC-DC Converter Controller

The NCP1083 implements a current mode DC-DC converter controller which is illustrated in Figure 16.

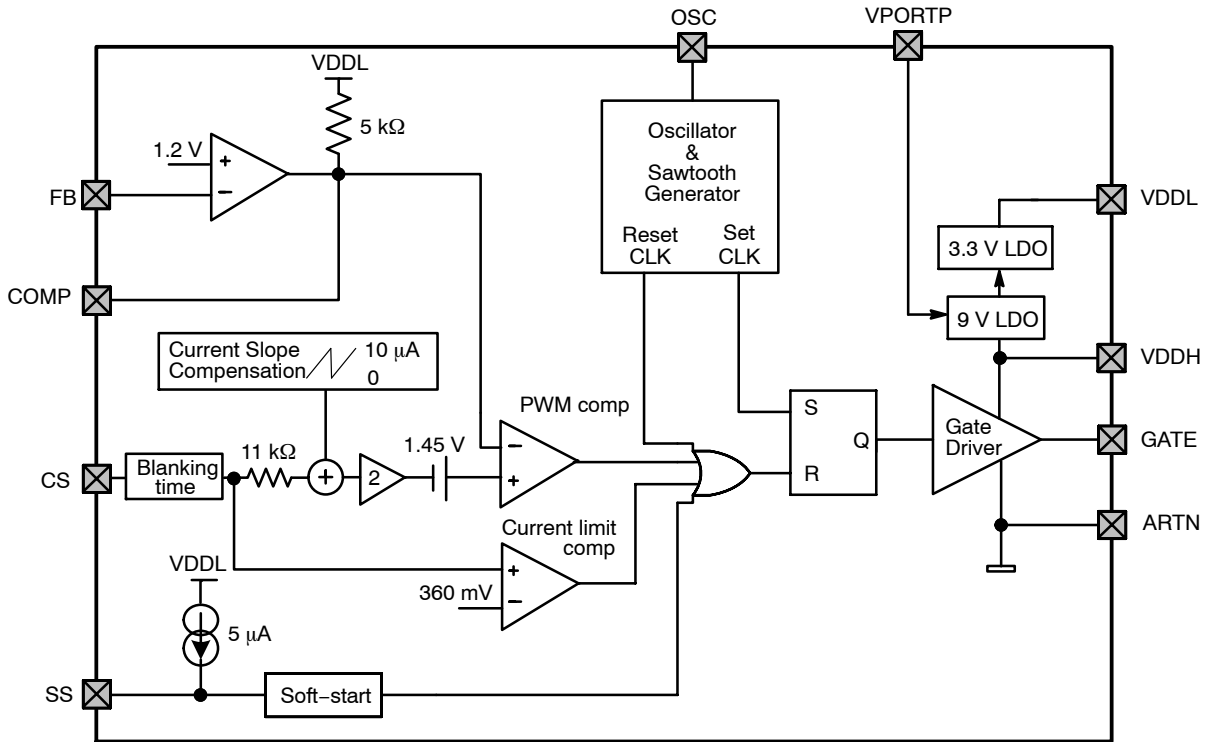

Figure 16. DC-DC Controller Block Diagram

Internal VDDH and VDDL Regulators and Gate Driver

An internal linear regulator steps down the VPORTP voltage to a 9 V output on the VDDH pin. VDDH supplies the internal gate driver circuit which drives the GATE pin and the gate of the external power MOSFET. The NCP1083 gate driver supports an external MOSFET with high V_{th} and high input gate capacitance. A second LDO regulator steps down the VDDH voltage to a 3.3 V output on VDDL. VDDL powers the analog circuitry of the DC-DC controller and

nCLASS_AT blocks. Moreover it can provide current to light a LED connected on the nCLASS_AT pin.

In order to prevent uncontrolled operations, both regulators include power-on-reset (POR) detectors which prevent the DC-DC controller from operating when either VDDH or VDDL is too low. In addition, an over-voltage lockout (OVLO) on the VDDH supply disables the gate driver in case of an open-loop converter with a configuration using the bias winding of the transformer (see Figure 4).

Both VDDH and VDDL regulators turn on as soon as VPORT reaches the Vuvlo_on threshold.

Error Amplifier

In non-isolated converter topologies, the high gain internal error amplifier of the NCP1083 and the internal 1.2 V reference voltage regulate the DC-DC output voltage. In this configuration, the feedback loop compensation network should be inserted between the FB and COMP pins as shown in Figures 3, 4 and 5.

In isolated topologies the error amplifier is not used because it is already implemented externally with the shunt regulator on the secondary side of the DC-DC controller (see Figure 2). Therefore the FB pin must be strapped to ARTN and the output transistor of the opto-coupler has to be connected on the COMP pin where an internal 5 kΩ pull-up resistor is tied to the VDDL supply (see Figure 16).

Soft-Start

The soft-start function provided by the NCP1083 allows the output voltage to ramp up in a controlled fashion, eliminating output voltage overshoot. This function is programmed by connecting a capacitor C_{SS} between the SS and ARTN pins.

While the DC-DC controller is in POR, the capacitor C_{SS} is fully discharged. After coming out of POR, an internal current source of 5 μA typically starts charging the capacitor C_{SS} to initiate soft-start. When the voltage on SS pin has reached 0.45 V (typical), the gate driver is enabled and DC-DC operation starts with a duty cycle limit which increases with the SS pin voltage. The soft-start function is finished when the SS pin voltage goes above 1.6 V for which the duty cycle limit reaches its maximum value of 80 percent.

Soft-start can be programmed by using the following equation:

$$t_{SS}(ms) = 0.23 \times C_{SS}(nF)$$

Current Limit Comparator

The NCP1083 current limit block behind the CS pin senses the current flowing in the external MOSFET for current mode control and cycle-by-cycle current limit. This is performed by the current limit comparator which, on the CS pin, senses the voltage across the external R_{cs} resistor located between the source of the MOSFET and the ARTN pin.

The NCP1083 also provides a blanking time function on CS pin which ensures that the current limit and PWM comparators are not prematurely triggered by the current spike that occurs when the switching MOSFET turns on.

Slope Compensation Circuitry

To overcome sub-harmonic oscillations and instability problems that exist with converters running in continuous conduction mode (CCM) and when the duty cycle is close or above 50 percent, the NCP1083 integrates a current slope compensation circuit. The amplitude of the added slope compensation is typically 110 mV over one cycle.

As an example, for an operating switching frequency of 250 kHz, the internal slope provided by the NCP1083 is 27.5 mV/ μA typically.

DC-DC Controller Oscillator

The frequency is configured with the R_{osc} resistor inserted between OSC and ARTN, and is defined by the following equation:

$$R_{OSC}(k\Omega) = \frac{38600}{F_{OSC}(kHz)}$$

The duty cycle limit is fixed internally at 80 percent.

MECHANICAL CASE OUTLINE PACKAGE DIMENSIONS

ON Semiconductor®



SCALE 1:1

TSSOP-20 EP
CASE 948AB-01
ISSUE O

DATE 17 JUN 2008

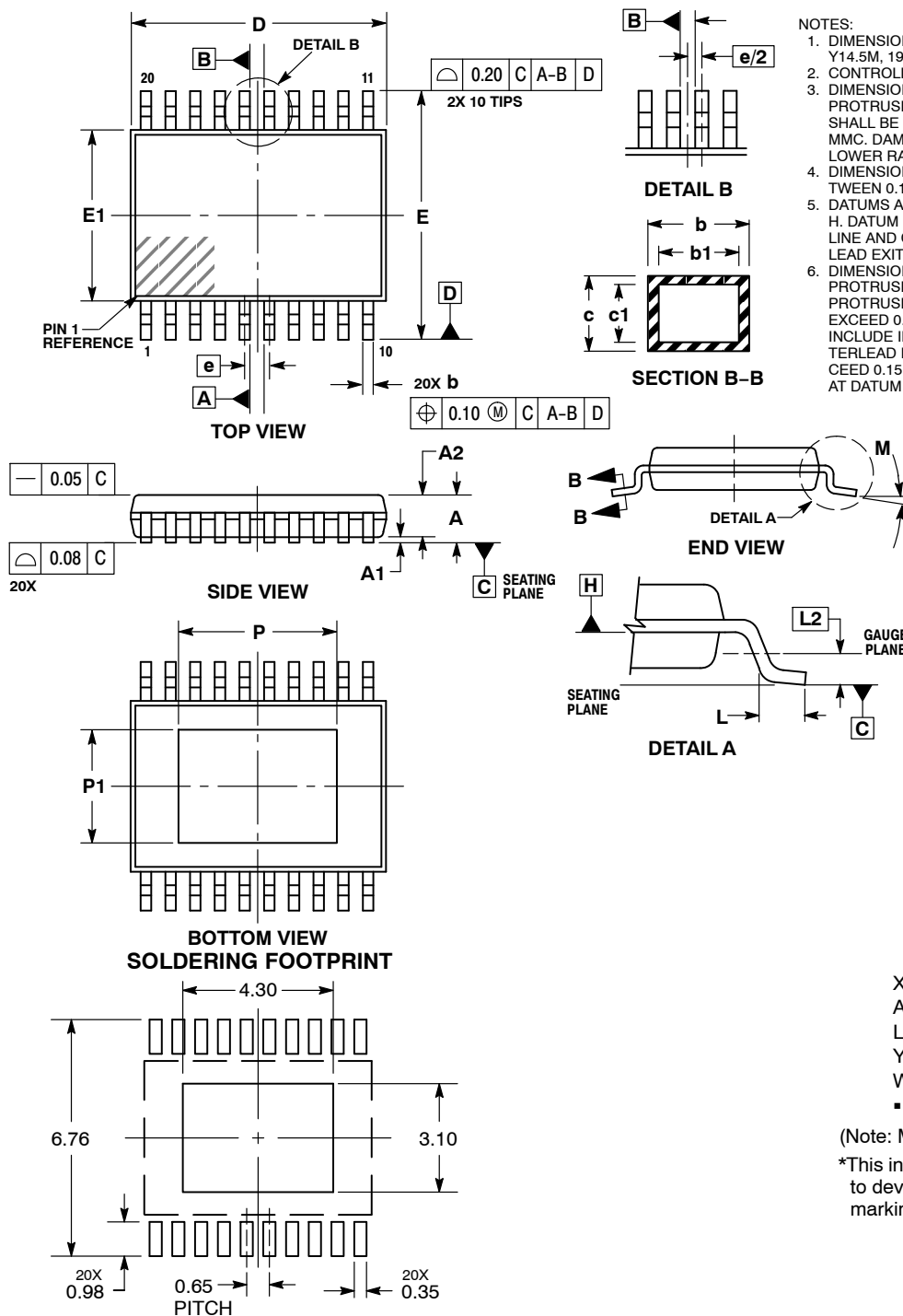

- NOTES:
1. DIMENSIONING AND TOLERANCING PER ASME Y14.5M, 1994.
 2. CONTROLLING DIMENSION: MILLIMETERS.
 3. DIMENSION b DOES NOT INCLUDE DAMBAR PROTRUSION. ALLOWABLE DAMBAR PROTRUSION SHALL BE 0.07 IN EXCESS OF THE LEAD WIDTH AT MMC. DAMBAR CANNOT BE LOCATED ON THE LOWER RADIUS OR THE FOOT OF THE LEAD.
 4. DIMENSIONS b, b1, c, c1 TO BE MEASURED BETWEEN 0.10 AND 0.25 FROM LEAD TIP.
 5. DATUMS A AND B ARE DETERMINED AT DATUM H. DATUM H IS LOCATED AT THE MOLD PARTING LINE AND COINCIDENT WITH LEAD WHERE THE LEAD EXITS THE PLASTIC BODY.
 6. DIMENSION D DOES NOT INCLUDE MOLD FLASH, PROTRUSIONS OR GATE BURRS. MOLD FLASH, PROTRUSIONS OR GATE BURRS SHALL NOT EXCEED 0.15 PER SIDE. DIMENSION E1 DOES NOT INCLUDE INTERLEAD FLASH OR PROTRUSION. INTERLEAD FLASH OR PROTRUSION SHALL NOT EXCEED 0.15 PER SIDE. D AND E1 ARE DETERMINED AT DATUM H.

DIM	MILLIMETERS	
	MIN	MAX
A	---	1.10
A1	0.05	0.15
A2	0.85	0.95
b	0.19	0.30
b1	0.19	0.25
c	0.09	0.20
c1	0.09	0.16
D	6.40	6.60
E	6.40 BSC	
E1	4.30	4.50
e	0.65 BSC	
L	0.50	0.70
L2	0.25 BSC	
M	0°	8°
P	---	4.20
P1	---	3.00

GENERIC MARKING DIAGRAM*

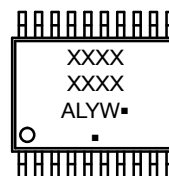

- XXXX = Specific Device Code
- A = Assembly Location
- L = Wafer Lot
- Y = Year
- W = Work Week
- = Pb-Free Package

(Note: Microdot may be in either location)
*This information is generic. Please refer to device data sheet for actual part marking.

DOCUMENT NUMBER:	98AON30874E	Electronic versions are uncontrolled except when accessed directly from the Document Repository. Printed versions are uncontrolled except when stamped "CONTROLLED COPY" in red.
DESCRIPTION:	TSSOP-20 EXPOSED PAD	PAGE 1 OF 1

ON Semiconductor and ON are trademarks of Semiconductor Components Industries, LLC dba ON Semiconductor or its subsidiaries in the United States and/or other countries. ON Semiconductor reserves the right to make changes without further notice to any products herein. ON Semiconductor makes no warranty, representation or guarantee regarding the suitability of its products for any particular purpose, nor does ON Semiconductor assume any liability arising out of the application or use of any product or circuit, and specifically disclaims any and all liability, including without limitation special, consequential or incidental damages. ON Semiconductor does not convey any license under its patent rights nor the rights of others.

onsemi, **Onsemi**, and other names, marks, and brands are registered and/or common law trademarks of Semiconductor Components Industries, LLC dba "**onsemi**" or its affiliates and/or subsidiaries in the United States and/or other countries. **onsemi** owns the rights to a number of patents, trademarks, copyrights, trade secrets, and other intellectual property. A listing of **onsemi**'s product/patent coverage may be accessed at www.onsemi.com/site/pdf/Patent-Marking.pdf. **onsemi** reserves the right to make changes at any time to any products or information herein, without notice. The information herein is provided "as-is" and **onsemi** makes no warranty, representation or guarantee regarding the accuracy of the information, product features, availability, functionality, or suitability of its products for any particular purpose, nor does **onsemi** assume any liability arising out of the application or use of any product or circuit, and specifically disclaims any and all liability, including without limitation special, consequential or incidental damages. Buyer is responsible for its products and applications using **onsemi** products, including compliance with all laws, regulations and safety requirements or standards, regardless of any support or applications information provided by **onsemi**. "Typical" parameters which may be provided in **onsemi** data sheets and/or specifications can and do vary in different applications and actual performance may vary over time. All operating parameters, including "Typicals" must be validated for each customer application by customer's technical experts. **onsemi** does not convey any license under any of its intellectual property rights nor the rights of others. **onsemi** products are not designed, intended, or authorized for use as a critical component in life support systems or any FDA Class 3 medical devices or medical devices with a same or similar classification in a foreign jurisdiction or any devices intended for implantation in the human body. Should Buyer purchase or use **onsemi** products for any such unintended or unauthorized application, Buyer shall indemnify and hold **onsemi** and its officers, employees, subsidiaries, affiliates, and distributors harmless against all claims, costs, damages, and expenses, and reasonable attorney fees arising out of, directly or indirectly, any claim of personal injury or death associated with such unintended or unauthorized use, even if such claim alleges that **onsemi** was negligent regarding the design or manufacture of the part. **onsemi** is an Equal Opportunity/Affirmative Action Employer. This literature is subject to all applicable copyright laws and is not for resale in any manner.

ADDITIONAL INFORMATION

TECHNICAL PUBLICATIONS:

Technical Library: www.onsemi.com/design/resources/technical-documentation
onsemi Website: www.onsemi.com

ONLINE SUPPORT: www.onsemi.com/support

For additional information, please contact your local Sales Representative at www.onsemi.com/support/sales