

THIS DRAWING IS UNPUBLISHED. RELEASED FOR PUBLICATION
 © COPYRIGHT BY TYCO ELECTRONICS CORPORATION. ALL RIGHTS RESERVED.

LOC	DIST	REVISIONS					
		P	LTR	DESCRIPTION	DATE	DWN	APVD
G	14		P	REV PER 0G3A-0832-04	27JAN05	JR	TM

AMP WIRE RANGE	Listed FILE E13288	LR7189 Certified
16-14 AWG SOLID OR STRANDED	16-14 AWG SOLID OR STRANDED	16-14 AWG SOLID OR STRANDED

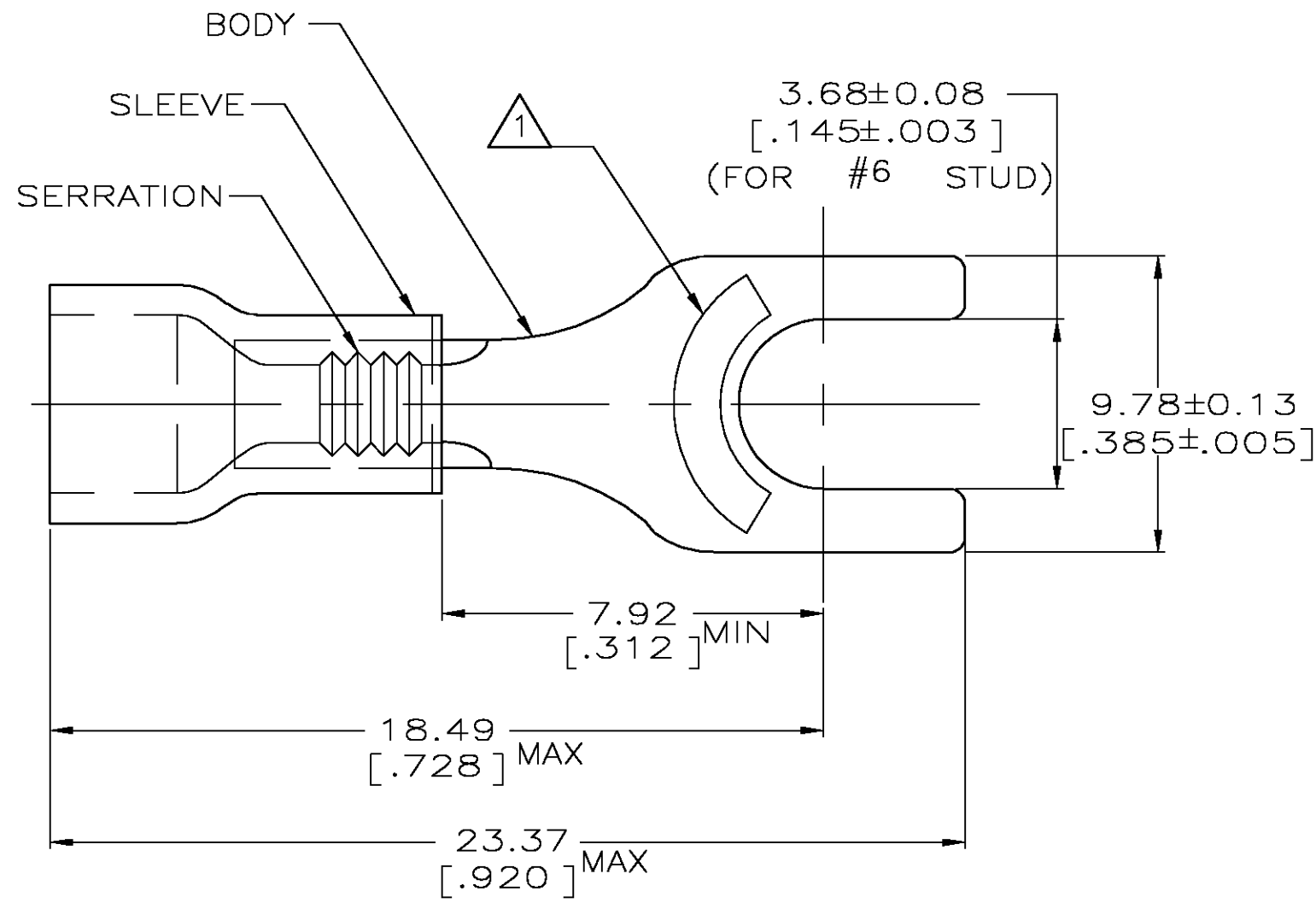

- ① STAMP AMP16-14* LOCATE APPROX AS SHOWN
- 2. WIRE INSUL DIA, 3.00-4.90 [.118-.193]
- 3. TONGUE MATL THK, 0.79 ± 0.05 [.031 ± .002]
- ④ REPLACED BY 34165
- ⑤ REPLACED BY 54367-2
- ⑥ MATERIAL: BODY - CU PER ASTM B152
SLEEVE - PVC, COLOR - BLUE

④	OBSOLETE	100	LOOSE PIECE, BOX	8-34165-1
⑤	OBSOLETE	5000	ON TAPE, REEL	2-34165-1
		1000	LOOSE PIECE	34165
		QTY	PACKAGE TYPE	PART NO

AMP INCORPORATED CUSTOMER SERVICE SYSTEMS		MAX RECOMMENDED OPERATING TEMPERATURE: 105°C [221° F]	THIS DRAWING IS A CONTROLLED DOCUMENT.		DWN G VINSON 07NOV94	Tyco Electronics Corporation Harrisburg, Pa 17105-3608			
FOR ADDITIONAL PRODUCT INFORMATION OR COPIES OF DRAWINGS AND TECHNICAL DOCUMENTS	PRODUCT INFORMATION CENTER 1-800-522-6752	VOLTAGE RATING: 600V (1000V FIXTURE OR SIGN)	DIMENSIONS: mm [INCHES]	TOLERANCES UNLESS OTHERWISE SPECIFIED:	CHK M ELLIS 07NOV94	NAME TERMINAL, SPADE, PLASTI-GRIP			
FOR APPLICATION TOOLING INFORMATION	TOOLING ASSISTANCE CENTER 1-800-722-1111	CIRCULAR MIL AREA: 1.04-2.62mm² [2,050-5,180] SOLID OR STRANDED		0 PLC ± - 1 PLC ± - 2 PLC ± 0.20 [.008] 3 PLC ± - 4 PLC ± - ANGLES ± -	APVD G NGO 07NOV94	APPLICATION SPEC UL 486A			
FOR ORDER ENTRY	1-800-526-5142	THIS DRAWING IS A CONTROLLED DOCUMENT FOR AMP INCORPORATED. IT IS SUBJECT TO CHANGE AND THE CONTROLLING ENGINEERING ORGANIZATION SHOULD BE CONTACTED FOR THE LATEST REVISION.	MATERIAL ⑥	FINISH -	PRODUCT SPEC -	SIZE A3	CAGE CODE 00779	DRAWING NO C-34165	RESTRICTED TO -
					CUSTOMER DRAWING		SCALE 6:1	SHEET 1 OF 1	REV P