

4

3

2

1

THIS DRAWING IS UNPUBLISHED. RELEASED FOR PUBLICATION, 19 .

© COPYRIGHT 19 BY AMP INCORPORATED. ALL RIGHTS RESERVED.

LOC	DIST	REVISIONS					
		P	LTR	DESCRIPTION	DATE	DWN	APVD
G	14		D	REV PER 0G3A-0013-01	20FEB01	JR	TM

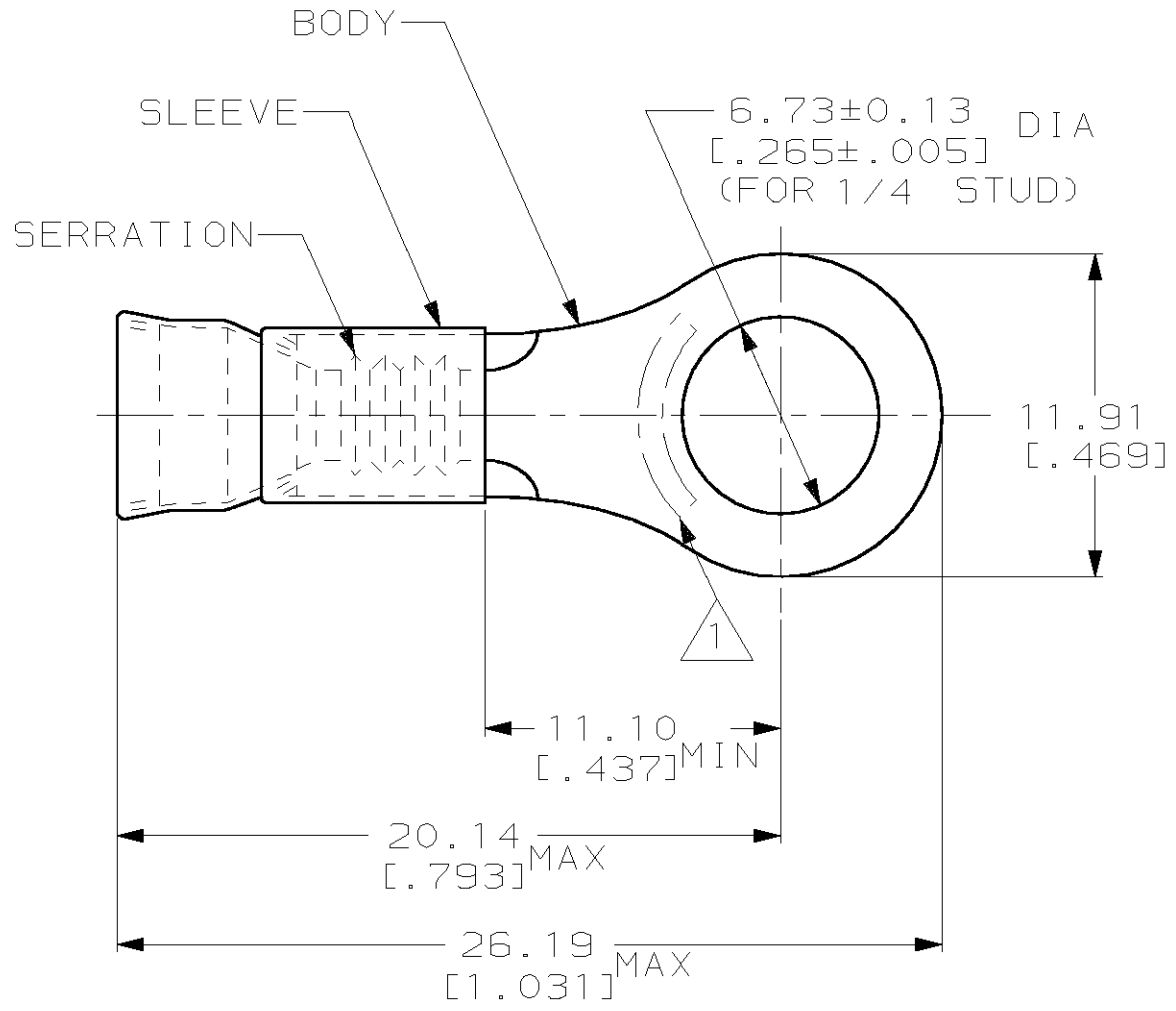

- 1. STAMP AMP 22-18* APPROX AS SHOWN
22-16 TERMINALS ARE STAMPED 22-18 IN
ACCORDANCE WITH MILITARY SPEC MIL-T-7928
COMMERCIAL WIRE RANGE IS 22-16
- 2. WIRE INSUL DIA, 2.67-3.56 [.105-.140]
- 3. TONGUE MATL THK, 0.79±0.05 [.031±.002]

1000	LOOSE PIECE	322367
QTY	PACKAGE TYPE	PART NO

AMP INCORPORATED CUSTOMER SERVICE SYSTEM		MAX RECOMMENDED OPERATING TEMPERATURE: 343°C [650°F]	THIS DRAWING IS A CONTROLLED DOCUMENT FOR AMP INCORPORATED. IT IS SUBJECT TO CHANGE AND THE CONTROLLING ENGINEERING ORGANIZATION SHOULD BE CONTACTED FOR THE LATEST REVISION.		DWN L OLMEDA 100CT94	AMP AMP Incorporated Harrisburg, PA 17105-3608
FOR ADDITIONAL PRODUCT INFORMATION OR COPIES OF DRAWINGS AND TECHNICAL DOCUMENTS	PRODUCT INFORMATION CENTER 1-800-522-6752	VOLTAGE RATING: -	DIMENSIONS: mm [in]	TOLERANCES UNLESS OTHERWISE SPECIFIED:	CHK M ELLIS 100CT94	
FOR APPLICATION TOOLING INFORMATION	TOOLING ASSISTANCE CENTER 1-800-722-1111	CIRCULAR MIL AREA: 0.26mm ² -1.65mm ² [509-3260]			APVD S BORTNER 100CT94	NAME TERMINAL, RING TONGUE, STRATOTHERM™, DIAMOND GRIP™, WIRE SIZE, 22-16 AWG
FOR ORDER ENTRY	1-800-526-5142	STRANDED WIRE	MATERIAL BODY, CU PER ASTM B152	FINISH BODY, NP, QQ-N-290	PRODUCT SPEC -	SIZE A3
			SLEEVE, NI SIL PER ASTM B122		APPLICATION SPEC -	CAGE CODE 00779
					WEIGHT -	DRAWING NO C-322367
					CUSTOMER DRAWING	SCALE 4:1
						SHEET 1 OF 1
						REV D