

PART NUMBER CODING

N E DHHN-T9

PLATING

(ALL PLATINGS ARE LEAD FREE AND HAVE 50µ" NICKEL UNDERPLATE)

CONTACT SURFACE	TERMINATION
W = GOLD FLASH	.000100" PURE TIN, MATTE
B = .000010" GOLD	.000100" PURE TIN, MATTE
C = .000030" GOLD	.000100" PURE TIN, MATTE

POSITIONS

18
32
49
82

TAIL LENGTH

1= 2.30[.091]
2= 2.54[.100]
3= 3.10[.122] 2.36[.093] PCB

COLOR

1= BLACK
2= BLUE
3= GREEN
4= PURPLE

REVISIONS				
REV.	ECO. NO	DESCRIPTION	DATE	BY
A	1595	INITIAL RELEASE	11/31/07	VJ
B	1707	UPDATE P/N CODING CHART, PLATING	05/30/08	ASK
C	1933	UPDATE DRAWING VIEWS, NOTES & DIM.	3/09/2009	JH

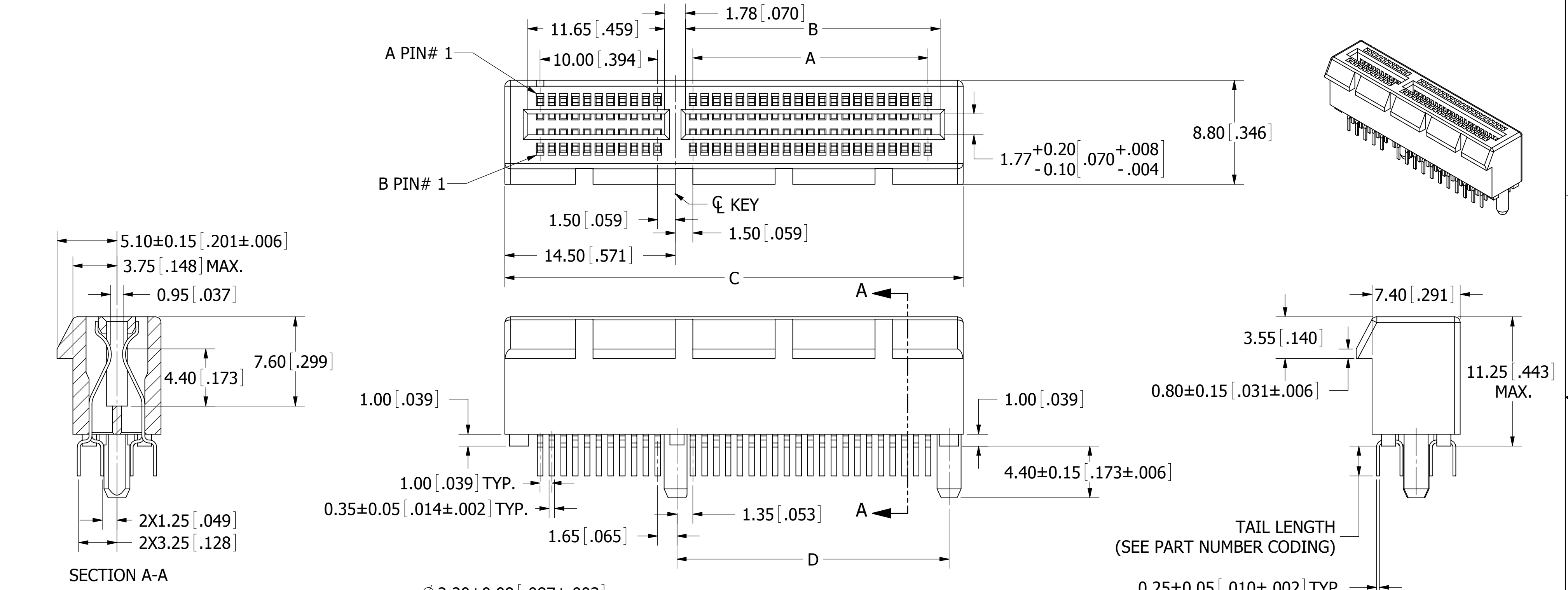

- NOTES:**
1. INSULATOR MATERIAL: NYLON46, UL 94V-0.
 2. CONTACT MATERIAL: PHOSPHOR BRONZE.
 3. CONTACT PLATING: SEE PART NUMBER CODING.
 4. CURRENT RATING: 1.1 AMP.
 5. INSULATOR RESISTANCE: 1000 MEGOHMS MIN.
 6. CONTACT RESISTANCE: 30 MILLI OHMS MAX.
 7. DIELECTRIC WITHSTANDING: 300V AC.
 8. INSERTION FORCE: 117gf (1.15 N) MAX PER CONTACT PAIR USING A 1.70 mm (.067") STEEL CARD.
 9. WITHDRAWAL FORCE: 15.3gf (0.15 N) MIN PER CONTACT PAIR USING A 1.44 mm (.057") STEEL CARD.
 10. OPERATING TEMPERATURE: -55° C TO +85° C.
 11. PROCESSING TEMP.: 260° C FOR 10 SECS MAX.
- (INDICATED TEMPERATURE AND TIME IS FOR COMPONENT INSULATOR. HIGHER PROCESSING TEMPERATURES MAY BE USED, PROVIDED HEAT IS APPLIED FROM BACK SIDE OF PCB, AND INSULATOR DOES NOT EXCEED INDICATED TEMPERATURE AND TIME.)

PART NUMBER	POSITIONS/ CONTACTS	A ± 0.10 [.004]		B +0.15/-0.05 [+0.006/-0.002]		C ± 0.23 [.009]		D ± 0.20 [.008]	
		MM	[INCH]	MM	[INCH]	MM	[INCH]	MM	[INCH]
N_E18DHHN-T9	18/36	6.00	0.236	7.65	0.301	25.00	0.984	9.15	0.360
N_E32DHHN-T9	32/64	20.00	0.787	21.65	0.852	39.00	1.535	23.15	0.911
N_E49DHHN-T9	49/98	37.00	1.457	38.65	1.522	56.00	2.205	40.15	1.581
N_E82DHHN-T9	82/164	70.00	2.756	71.65	2.821	89.00	3.504	73.15	2.880



UNLESS OTHERWISE SPECIFIED:
DIMENSIONS ARE IN MM [INCHES]
TOLERANCES:
ANGULAR: ± 5°
.X = ± .30 [.012]
.XX = ± .20 [.008]
.XXX = ± .10 [.004]
SURFACE FINISH: 63 Rc
REMOVE ALL BURRS AND SHARP EDGES .010 MAX

INTERPRET DIMENSIONS AND GEOMETRIC TOLERANCING PER: ANSI Y14.5M-1994

DATE	NAME	
DRAWN 3/09/09	JH	
<small>THE INFORMATION HEREIN CONTAINS PROPRIETARY INFORMATION OF SULLINS ELECTRONICS AND IS NOT TO BE REPRODUCED, USED OR DISCLOSED TO OTHERS FOR ANY PURPOSE EXCEPT AS SPECIFICALLY AUTHORIZED IN WRITING BY AN OFFICER OF SULLINS ELECTRONICS.</small>		DESCRIPTION PCI EXPRESS, 1mm CC, DIP SOLDER PART NUMBER N_E_DHHN-T9
SIZE	DWG. NO.	REV.
C	11045	C
SCALE: 5:1		SHEET 1 OF 2

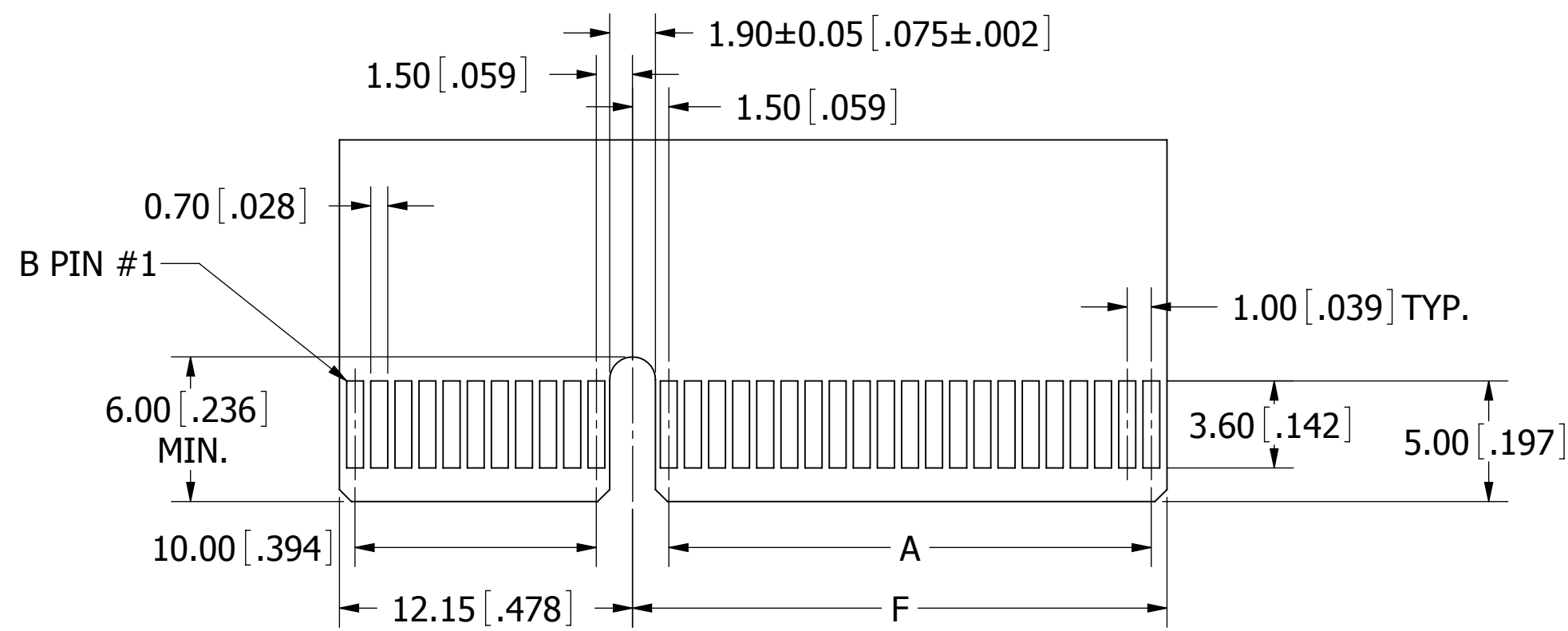

**ADD-IN CARD EDGE-FINGER DIMENSIONS
(TOLERANCE: ±0.05[.002])**

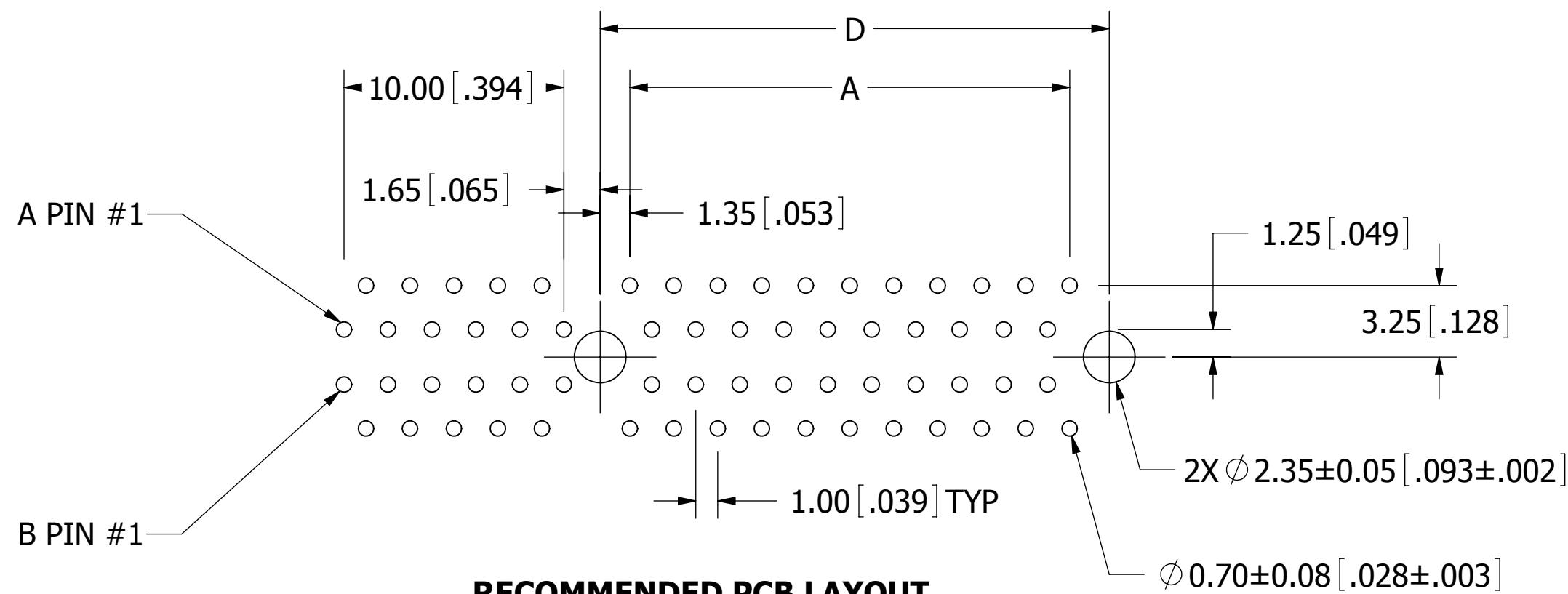
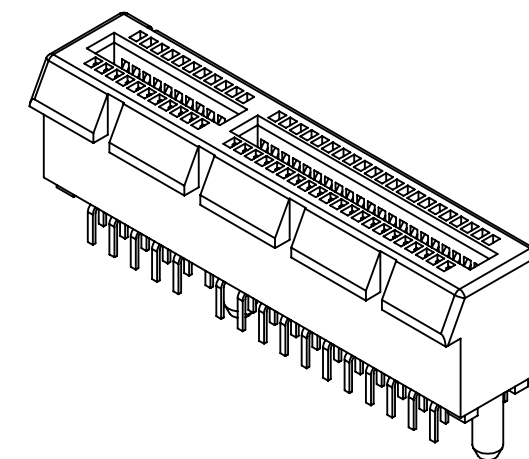

**RECOMMENDED PCB LAYOUT
(TOLERANCE: ±0.05[.002])**

PART NUMBER	POSITIONS/ CONTACTS	A ± 0.10 [.004]		D ± 0.20 [.008]		F ± 0.20 [.008]	
		MM	[INCH]	MM	[INCH]	MM	[INCH]
N_E18DHHN-T9__	18/36	6.00	0.236	9.15	0.360	8.15	0.321
N_E32DHHN-T9__	32/64	20.00	0.787	23.15	0.911	22.15	0.872
N_E49DHHN-T9__	49/98	37.00	1.457	40.15	1.581	39.15	1.541
N_E82DHHN-T9__	82/164	70.00	2.756	73.15	2.880	72.15	2.841

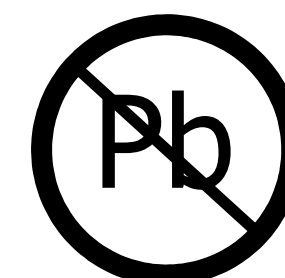

RoHS COMPLIANT

DESCRIPTION PCI EXPRESS, 1mm CC, DIP SOLDER		
PART NUMBER N_E__DHHN-T9__		
SIZE C	DWG. NO. 11045	REV C
SCALE: NTS		SHEET 2 OF 2